

# 1310nm Laser Diode

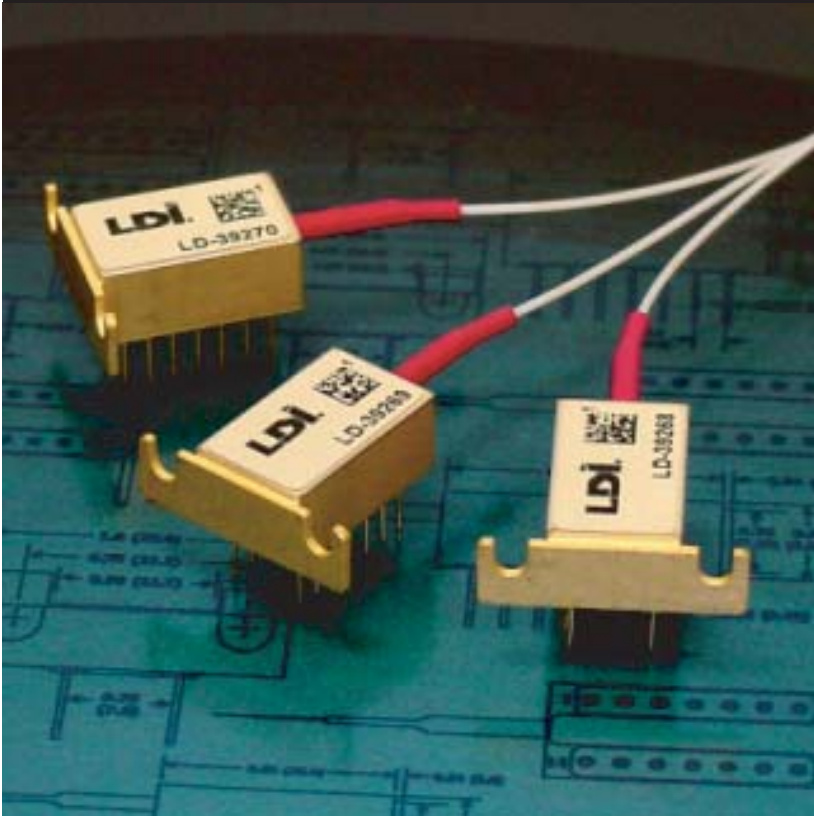

Power to 2mW

Singlemode 9/125/900 fiber

14-pin DIP

Buried Hetero-Structure  
laser design

High stability fiber coupling

Hermetically sealed

Excellent output power and wavelength stability are features of Laser Diode Incorporated's laser series. These modules are ideal for applications such as telecommunications and test instrumentation.

These devices comprise a Fabry-Perot laser chip coupled to a singlemode optical fiber packaged in LDI's high stability, temperature controlled, 14-pin dual-in-line module. LDI's laser chips are based on a buried hetero-structure using MOCVD technology.



Laser-welded fiber alignment assembly for long-term power stability.

The resulting characteristics are high efficiency, excellent thermal stability, moderate threshold current, and bandwidth greater than 1 GHz. The module includes; a photodiode for monitoring the laser chip output power, a thermistor for monitoring the laser submount temperature, and a Peltier-effect thermoelectric cooler. The cooler can be used to maintain a constant laser temperature or to temperature tune the spectral frequency of the laser. Proven module design and a rigorous quality assurance program ensure the reliability and long operational life of these products.

The SCW 1301 Series lasers have a nominal wavelength of 1310nm. The light output is coupled into a singlemode optical fiber with a core diameter of 9um and a cladding diameter of 125um. The fiber has a protective tight buffer upjacket of 900um diameter Hytrel®.

These lasers are typically used in short and intermediate distance telecommunications systems including protocols such as SONET, SDH, and PDH. They are also used in long distance, high-speed data communications network applications such as "fast" Ethernet or Fiberchannel. The SCW 1301 is an excellent device for use in high-stability test equipment products.

Hytrel is a trademark of Dupont.

## Specifications and Limits @ 25°C

		Power Options (uW)		
		500	1000	2000
<b>Spectral Characteristics</b>				
Wavelength Range	nm	1270-1330	1270-1330	1270-1330
Spectral width, RMS (typ)	nm	1.7	1.7	1.7
Spectral width, FWHM (typ)	nm	2	2	2
<b>Drive Characteristics</b>				
Threshold current (typ;max)	mA	6;15	6;15	6;15
Modulation current (typ;max)	mA	10;25	10;25	15;25
Forward voltage maximum	V	2	2	2
Maximum optical rise/fall time	ns	0.5	0.5	0.5
<b>Monitor Diode</b>				
Photocurrent at P <sub>MAX</sub> (min;max)	uA	50;1200	50;1200	50;1200
Maximum dark current	nA	10	10	10
Maximum capacitance	pF	6	6	6
Maximum rise/fall time	ns	2	2	2
Maximum reverse voltage	V	10	10	10
Tracking error *	dB	±0.5	±0.5	±0.5
<b>Temperature Range</b>				
Module operating temperature	°C	-20 to +70	-20 to +70	-20 to +70
Storage temperature	°C	-40 to +85	-40 to +85	-40 to +85
<b>Thermoelectric Cooler</b>				
Maximum cooler capacity	°C	45	45	45
Current for maximum capacity	A	.75	.75	.75
Maximum current	A	1.2	1.2	1.2
Voltage for maximum current	V	1.2	1.2	1.2
<b>Thermistor</b>				
Resistance at T = 25°C	KΩ	9.8-10.2	9.8-10.2	9.8-10.2
Temperature coefficient	%/°C	-4.4	-4.4	-4.4

### Notes:

\* Tracking error is the variation of the linear relationship between fiber-coupled power and monitor diode current over the specified operating temperature range.

### Typical Laser Characteristics

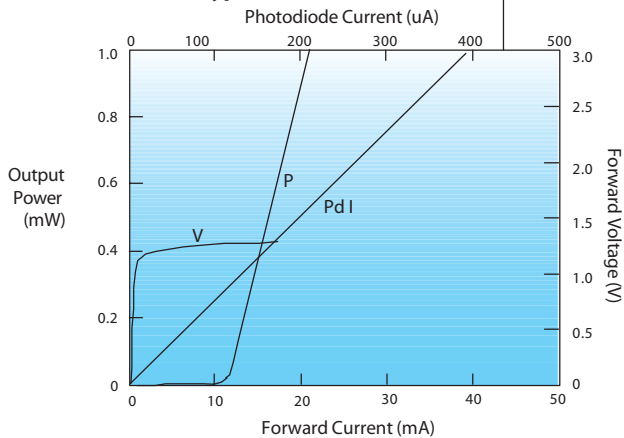

### Typical Device Spectrum

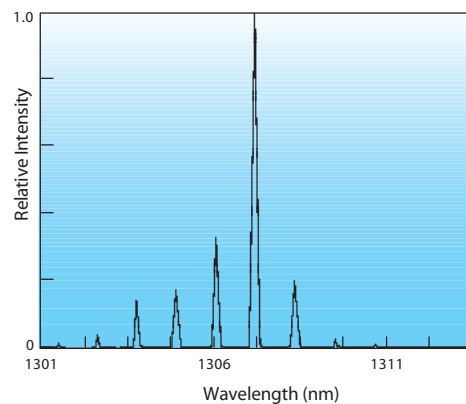

# SCW-1301 Package

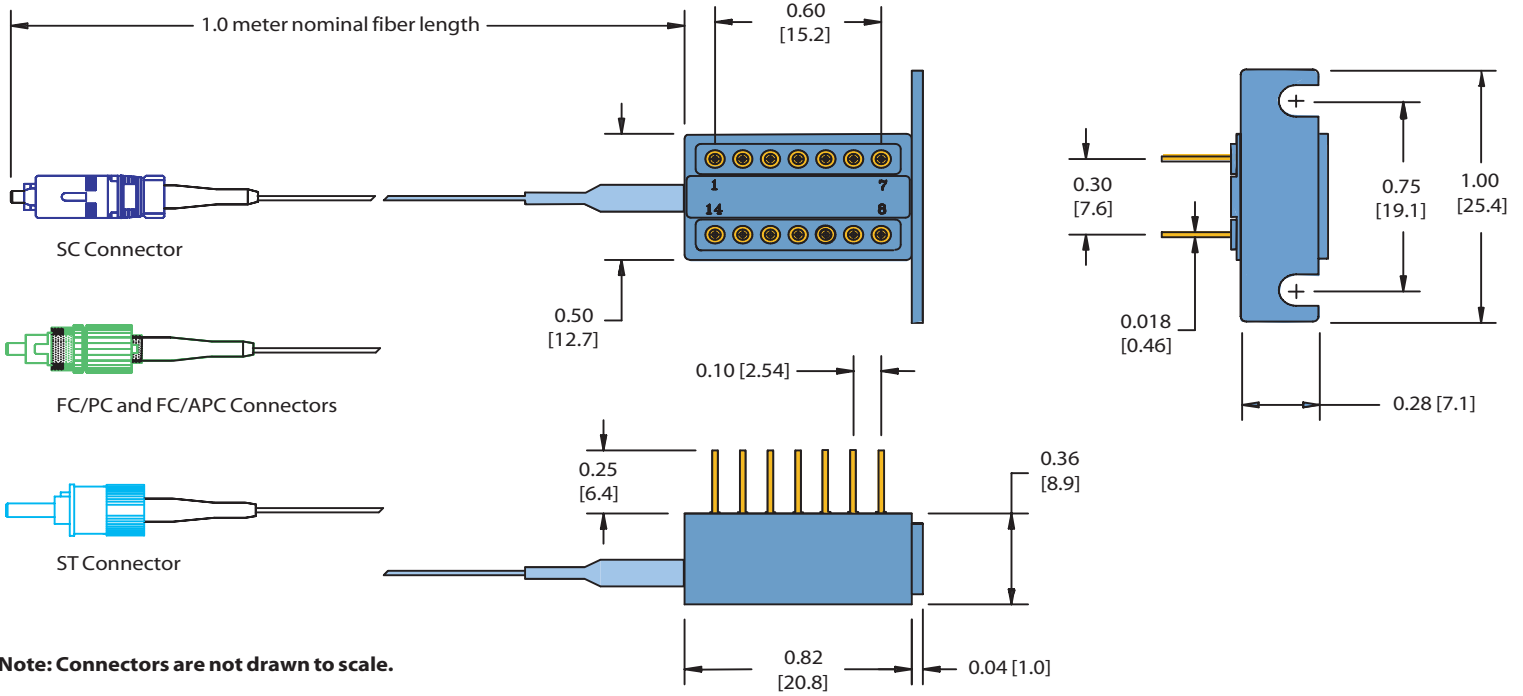

Note: Connectors are not drawn to scale.

## Application Notes

A laser diode can be damaged by an overdrive condition or a very short duration transient spike. It is advisable to protect the laser diode by providing a slow-start circuit to ramp the driver current to the appropriate DC level. Commercial drivers are available in circuit form.

The monitor photodiode in this device reads the optical power from the rear facet of the laser diode. This technique provides a good indication of the level and stability of the optical power that is coupled from the front facet of the laser into the optical fiber. The current from the monitor diode is typically used in a dynamic feedback loop to control the laser drive current and thus maintain a constant optical output level.

This laser package incorporates a Peltier-effect thermoelectric cooler (TEC). It is imperative that the TEC is running when the laser chip is operating to prevent thermal damage to the laser. The thermistor that measures 10 Kohms at 25°C is mounted close to the laser chip to provide feedback to the temperature controller. A simple drive circuit for the TEC is included in this document.

Pin Assignments			
F SERIES		G SERIES	
Pin	Function	Pin	Function
1	Cooler anode (+)	1	Cooler anode (+)
2,3,4,6,13	No connection	2,3,4,6,12,13	No connection
5	Ground, laser anode (+)	5	Ground, laser anode (+)
7	Detector cathode (-)	7	Detector cathode (-)
8	Detector anode (+)	8	Detector anode (+)
9	Laser cathode (-)	9	Laser cathode (-)
10	Ground	10	Ground, thermistor
11,12	Thermistor	11	Thermistor
14	Cooler cathode (-)	14	Cooler cathode (-)

## Thermoelectric Cooler Control

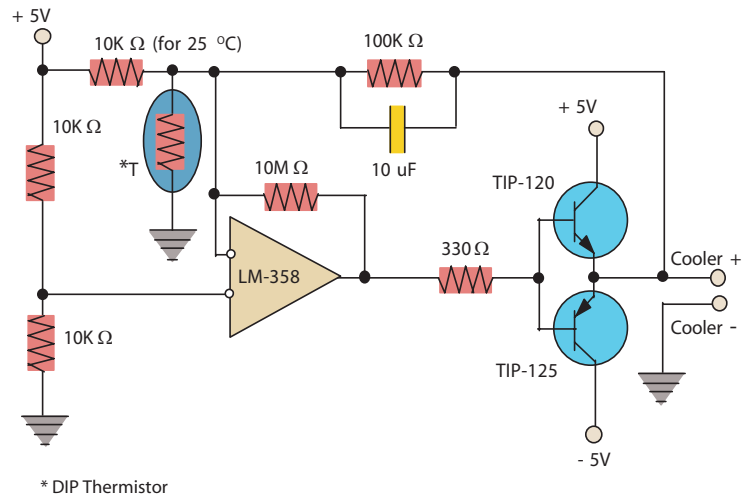

# 1310nm Laser Diode

## Product Changes

Laser Diode Incorporated reserves the right to make changes to the product(s) or information contained herein without notice. No liability is assumed as a result of their use or application.

## Personal Hazard

Normal aversion reactions will protect from radiation hazards to the eye associated with devices of this kind. Direct and prolonged exposure to a laser beam may cause eye damage. Observe precautions accompanying the product and precautions appropriate to a Class IIIb laser.

## Handling Precautions

Handle optical fiber with normal care, avoiding stretch, tension, twist, kink, or bend abuse. Products are subject to the risk normally associated with sensitive electronic devices including static discharge, transients, and overload.

## Special Orders

Some products are supplied with performance characteristics to meet unique customer requirements and differ from those indicated herein. Contact the Laser Diode Incorporated Sales Department or your local representative to discuss your individual requirements. For a complete listing of representatives, visit our website at [www.laserdiode.com](http://www.laserdiode.com).

## Ordering

Products can be ordered directly from Laser Diode Incorporated or its representatives. For a complete listing of representatives, visit our website at [www.laserdiode.com](http://www.laserdiode.com). Refer to the following part numbers:

## Ordering Information

Part Number	Description
SCW 1301X-050XX	laser, 1310nm, 500 uW, 14-pin DIP, TEC, 9/125/900 um pigtail
SCW 1301X-100XX	laser, 1310nm, 1000 uW, 14-pin DIP, TEC, 9/125/900 um pigtail
SCW 1301X-200XX	laser, 1310nm, 2000 uW, 14-pin DIP, TEC, 9/125/900 um pigtail

### Note:

To indicate the thermistor pin assignment you require, substitute one of the following designations for the "X" in the above table:

Use **F** (floating thermistor) to indicate F Series pinout.

Use **G** (grounded thermistor) to indicate G Series pinout.

To indicate the pigtail connector termination you require, substitute one of the following designations for the "XX" in the above table:

Use **FC** to indicate an FC/PC type connector.

Use **LC** to indicate an LC/PC type connector.

Use **SC** to indicate an SC/PC type connector.

Use **ST** to indicate an ST<sup>®</sup> type connector.

For no connector, omit suffix.

*ST is a trademark of Lucent Technologies Inc.*

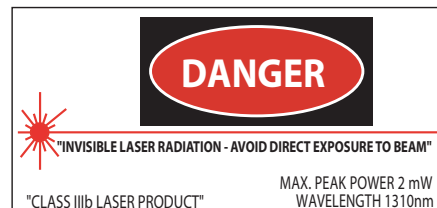

**CAUTION:** Use of controls, adjustments, or performance of procedures other than specified herein may result in hazardous radiation exposure.