

# OSC-15801 SYNCHRO/RESOLVER/INDUCTOSYN<sup>®</sup> REFERENCE OSCILLATOR

Make sure the next  
Card you purchase  
has...



## FEATURES

- Quadrature Reference Output Voltages for Inductosyn Applications
- Programmable Output Frequency from 400 Hz to 20 kHz
- Small 18-Pin DDIP
- Scalable Reference Output
- -55°C to 125°C Operating Temperature Range

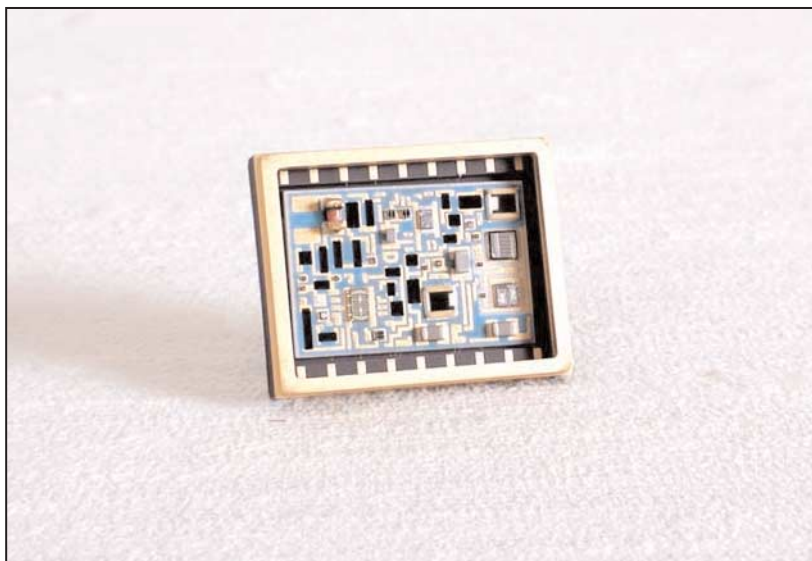

## DESCRIPTION

The OSC-15801 is a quadrature power oscillator with two outputs that are 90° out of phase. These outputs provide both the reference and quadrature signals, simultaneously, making the OSC-15801 ideally suited for Inductosyn applications.

The oscillator's outputs are pin-programmable for both frequency and amplitude. The output frequency can be programmed from 400 Hz to 20 kHz by simply connecting two external capacitors. The Reference output voltage, 8.8 Vrms at 20 kHz, can be scaled down by connecting a single resistor.

## APPLICATIONS

Packaged in an 18-pin hermetic DDIP, the OSC-15801 operates over a temperature range of -55°C to +125°C. This, combined with its small size and programmable output voltage and frequency capabilities, makes it an excellent choice for use in Inductosyn applications.

FOR MORE INFORMATION CONTACT:

Technical Support:  
1-800-DDC-5757 ext. 7382



Data Device Corporation  
105 Wilbur Place  
Bohemia, New York 11716  
631-567-5600 Fax: 631-567-7358  
[www.ddc-web.com](http://www.ddc-web.com)

All trademarks are the property of their respective owners.

© 1981, 1999 Data Device Corporation

® Inductosyn is a registered trademark of Farrand Controls Corporation

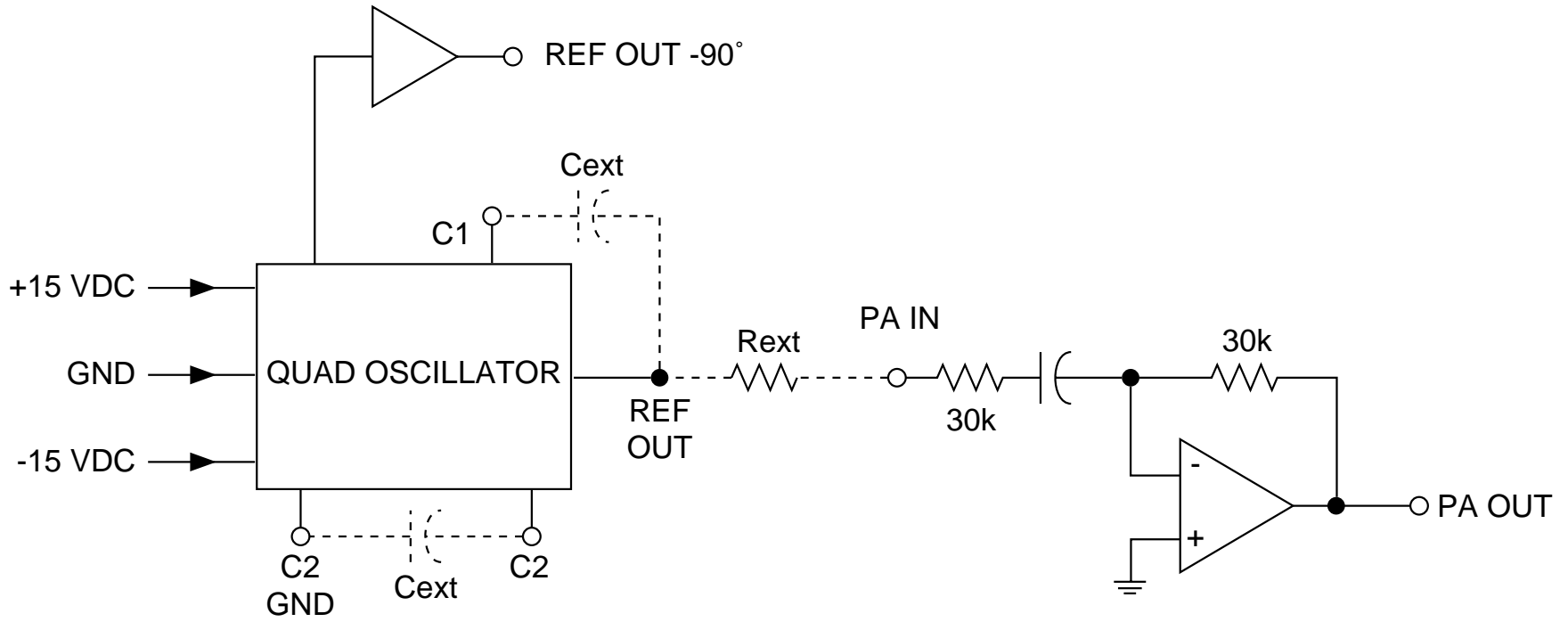

FIGURE 1. OSC-15801 BLOCK DIAGRAM

**TABLE 1. OSC-15801 SPECIFICATIONS**

Specifications apply over temperature range and power supply range.

PARAMETER	UNITS	VALUE
<b>FREQUENCY</b>	Hz	Programmable from 400 to 20k
<b>OUTPUTS</b> (Note 1) PA OUT Voltage Continuous Current Protection  REF Voltage Continuous Current Protection  REF -90° Voltage Continuous Current Protection  Output Impedance	V rms mA rms  V rms mA rms  V rms mA rms  Ω	7.1 to 8.8 215 max Momentary short circuit (1 sec. max.)  7.1 to 8.8 3 max Momentary short circuit (5 sec. max.)  (Note 2) 3 max Momentary short circuit (5 sec. max.)  0.87 (typ)
<b>POWER SUPPLIES</b> Voltage Current Max Voltage without damage	Vdc mA Vdc	±15 ±5% 10 max plus current load ±18
<b>TEMPERATURE RANGE</b> Operating -10X -30X Storage JC (Junction to Case)	°C °C °C °C/W	-55 to +125 0 to +70 -65 to +150 8
<b>PHYSICAL CHARACTERISTICS</b> Size  Package Type Weight	in (mm)  oz (gm)	1.0 x 0.8 x 0.2 (25.45 x 20.32 x 4.83) 18-pin DDIP 0.4 (1)

Notes:

1. Output voltage tracks ±15 V supply levels.
2. Clipped sine wave for demodulator drive only, 10 Vrms typ.

## OSC-15801 OPERATION

### PROGRAMMABLE FREQUENCY OUTPUT

The output frequency of the OSC-15801 is programmable from 20 kHz down to 400 Hz. The frequency is programmed using two external equal value capacitors (see FIGURE 2). The value of the capacitors ( $C_{ext}$ ) is calculated as follows:

$$C_{ext} = (2,400,000/f) - 100$$

where:  $C_{ext}$  is capacitance in picofarads,  
f is frequency in Hertz.

### PROGRAMMABLE REFERENCE VOLTAGE OUTPUT

The PA OUT (REF), pin 13, provides from 7.1 to 8.8 Vrms, depending on the operating frequency. TABLE 2 lists the PA OUT voltages at the (programmed) operating frequency. These voltages are the maximum voltages obtained at these frequencies, with the  $R_{ext} = 0$  Ohms (pin 7 jumped to pin 3).

TABLE 2. PA OUT/FREQUENCY	
PA OUT	FREQUENCY
8.8 Vrms	20 kHz
7.5 Vrms	10 kHz
7.1 Vrms	.4 kHz

To scale down the PA OUT voltage, an external resistor ( $R_{ext}$ ) is connected between pins 3 and 7. The value of  $R_{ext}$  is calculated as follows:

$$R_{ext} = 30 [(PA\ OUT/desired\ voltage) - 1]$$

where:  $R_{ext}$  is in kOhms,  
desired voltage is in Vrms,  
PA OUT is dependent on frequency used.

**FOR EXAMPLE**, to scale down PA OUT to 5 Vrms at 10 kHz, the value of  $R_{ext}$  would be calculated as follows:

$$R_{ext} = 30 [(PA\ OUT/desired\ voltage) - 1]$$

$$R_{ext} = 30 [(7.5/5) - 1]$$

$$R_{ext} = 15k\Omega$$

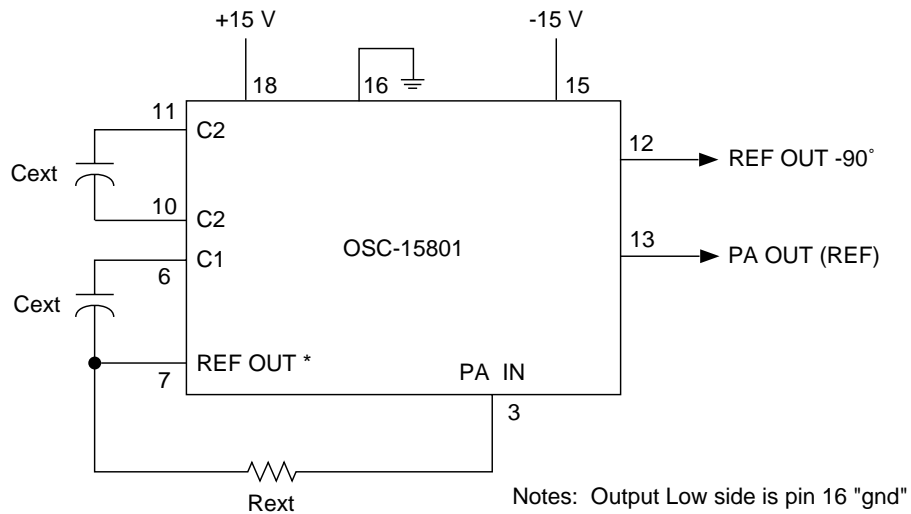

**FIGURE 2. PROGRAMMING RESISTOR AND CAPACITOR CONNECTIONS**

TABLE 3. OSC-15801 PIN FUNCTIONS		
PIN	NAME	FUNCTION
1	NC	No connection
2	NC	No connection
3	PA IN	Power amplifier inverting input
4	NC	No connection
5	NC	No connection
6	C1	Capacitor connection (pin-programmable frequency)
7	REF OUT	Reference output
8	NC	No connection
9	NC	No connection
10	C2	Capacitor connection (pin-programmable frequency)
11	C2 GND	Capacitor connection (pin-programmable frequency)
12	REF OUT -90°	-90° reference output signal
13	PA OUT	Power amplifier output
14	NC	No connection
15	-15 V	-15 Vdc power supply voltage
16	GND	Ground
17	NC	No connection
18	+15 V	+15 Vdc power supply voltage

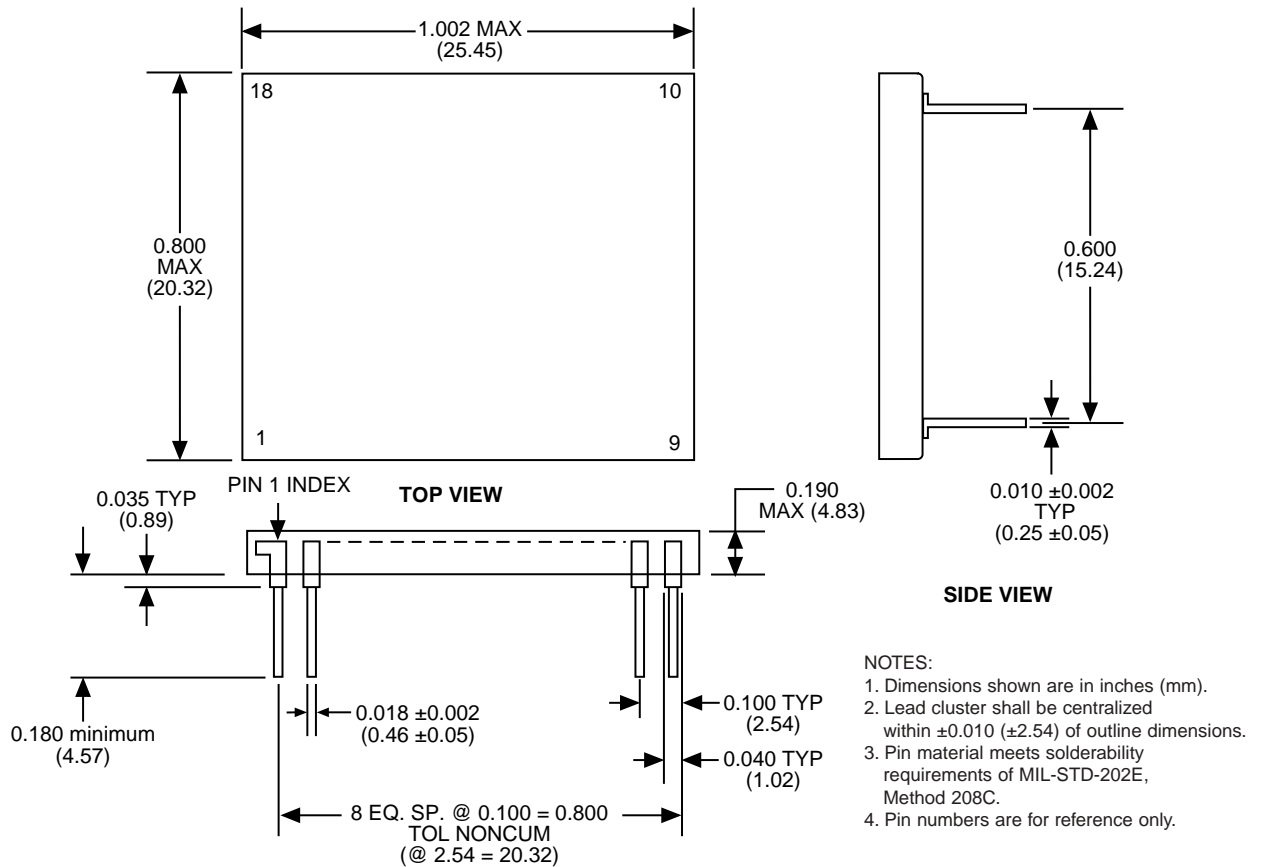

**FIGURE 3. OSC-15801 MECHANICAL OUTLINE**

## NOTES

## ORDERING INFORMATION

OSC-15801-XX0X

### Supplemental Process Requirements:

- S = Pre-Cap Source Inspection
- L = Pull Test
- Q = Pull Test and Pre-Cap Inspection
- K = One Lot Date Code
- W = One Lot Date Code and Pre-Cap Source
- Y = One Lot Date Code and 100% Pull Test
- Z = One Lot Date Code, Pre-Cap Source and 100% Pull Test
- Blank = None of the Above

### Process Requirements:

- 0 = Standard DDC Processing, no Burn-In
- 1 = MIL-PRF-38534 Compliant
- 2 = B\*
- 3 = MIL-PRF-38534 Compliant with PIND Testing
- 4 = MIL-PRF-38534 Compliant with Solder Dip
- 5 = MIL-PRF-38534 Compliant with PIND Testing and Solder Dip
- 6 = B\* with PIND Testing
- 7 = B\* with Solder Dip
- 8 = B\* with PIND Testing and Solder Dip
- 9 = Standard DDC Processing with Solder Dip, no Burn-In

### Temperature Grade/Data Requirements:

- 1 = -55°C to +125°C
- 2 = -40°C to +85°C
- 3 = 0°C to +70°C
- 4 = -55°C to +125°C with Variables Test Data
- 5 = -40°C to +85°C with Variables Test Data
- 8 = 0°C to +70°C with Variables Test Data

\*Standard DDC Processing with burn-in and full temperature test - see table below

STANDARD DDC PROCESSING		
TEST	MIL-STD-883	
	METHOD(S)	CONDITION(S)
INSPECTION	2009, 2010, 2017, and 2032	—
SEAL	1014	A and C
TEMPERATURE CYCLE	1010	C
CONSTANT ACCELERATION	2001	A
BURN-IN	1015, Table 1	—

The information in this data sheet is believed to be accurate; however, no responsibility is assumed by Data Device Corporation for its use, and no license or rights are granted by implication or otherwise in connection therewith.  
Specifications are subject to change without notice.

Please visit our web site at [www.ddc-web.com](http://www.ddc-web.com) for the latest information.



105 Wilbur Place, Bohemia, New York, U.S.A. 11716-2482

**For Technical Support - 1-800-DDC-5757 ext. 7382**

**Headquarters, N.Y., U.S.A.** - Tel: (631) 567-5600, Fax: (631) 567-7358

**Southeast, U.S.A.** - Tel: (703) 450-7900, Fax: (703) 450-6610

**West Coast, U.S.A.** - Tel: (714) 895-9777, Fax: (714) 895-4988

**United Kingdom** - Tel: +44-(0)1635-811140, Fax: +44-(0)1635-32264

**Ireland** - Tel: +353-21-341065, Fax: +353-21-341568

**France** - Tel: +33-(0)1-41-16-3424, Fax: +33-(0)1-41-16-3425

**Germany** - Tel: +49-(0)8141-349-087, Fax: +49-(0)8141-349-089

**Japan** - Tel: +81-(0)3-3814-7688, Fax: +81-(0)3-3814-7689

**World Wide Web** - <http://www.ddc-web.com>



DATA DEVICE CORPORATION  
REGISTERED TO ISO 9001  
FILE NO. A5976