

# Audio processor – companding, VOX and amplifier section

# SA5752

## DESCRIPTION

The SA5752 is a high performance low power audio signal processing system especially designed to meet the requirements for small size and low voltage operation of hand-held equipment. The SA5752 subsystem includes a low noise microphone preamplifier with adjustable gain, a noise cancellation switching amplifier with adjustable threshold, a voice operated transmitter (VOX) switch, VOX control, an audio compressor with buffered input, audio expander, and an internal bandgap voltage regulator with power down capability. When used with Philips Semiconductors' SA5753, the complete audio processing function of an AMPS or TACS cellular telephone is easily implemented. The system also meets the requirements of the proposed NAMPS or NTACS specifications. The SA5752 can also be used without the SA5753 in a wide variety of radio communications applications.

## FEATURES

- Operating voltage range: 2V to 5.5V
- Miniature SSOP and SO packages
- High performance
- Adjustable VOX and noise cancellation threshold
- Adjustable gain preamplifier
- Audio companding
- ESD protected
- Open collector VOX output
- Logic inputs CMOS compatible
- Power down mode
- Few external components
- Meets AMPS/TACS/NAMPS/NTACS requirements

## ORDERING INFORMATION

DESCRIPTION	TEMPERATURE RANGE	ORDER CODE	DWG #
20-Pin Plastic Small Outline Large (SOL) package	-40 to +85°C	SA5752D	SOT163-1
20-Pin Plastic Shrink Small Outline Package (SSOP)	-40 to +85°C	SA5752DK	SOT266-1

## PIN CONFIGURATION

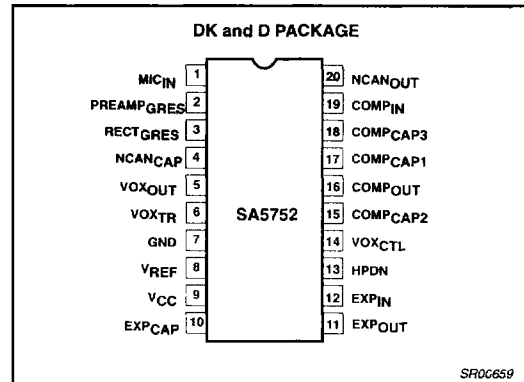

Figure 1. Pin Configuration

## BENEFITS

- Very compact applications
- Long battery life in portable equipment
- Complete cellular audio function with the SA5753

## APPLICATIONS

- Cellular radio
- Mobile communications
- High performance cordless telephones
- 2-way radio

## Audio processor – companding, VOX and amplifier section

SA5752

## PIN DESCRIPTIONS

PIN NO.	SYMBOL	DESCRIPTION
1	MIC <sub>IN</sub>	Microphone input
2	PREAMP <sub>GRES</sub>	Preamplifier gain resistor
3	RECT <sub>GRES</sub>	Rectifier gain resistor
4	NCAN <sub>CAP</sub>	Noise cancellation timing capacitor
5	VOX <sub>OUT</sub>	Voice operated transmission output
6	VOX <sub>TR</sub>	Voice operated transmission threshold resistor
7	GND	Ground
8	V <sub>REF</sub>	Reference voltage
9	V <sub>CC</sub>	Positive supply
10	EXP <sub>CAP</sub>	Expander timing capacitor
11	EXP <sub>OUT</sub>	Expander output
12	EXP <sub>IN</sub>	Expander input
13	HPDN	Hardware power-down
14	VOX <sub>CTL</sub>	Voice operated transmission control
15	COMP <sub>CAP2</sub>	Compressor capacitor 2 DC block
16	COMP <sub>OUT</sub>	Compressor output
17	COMP <sub>CAP1</sub>	Compressor timing capacitor 1
18	COMP <sub>CAP3</sub>	Compressor capacitor 3 DC block
19	COMP <sub>IN</sub>	Compressor input
20	NCAN <sub>OUT</sub>	Noise cancellation output

## BLOCK DIAGRAM

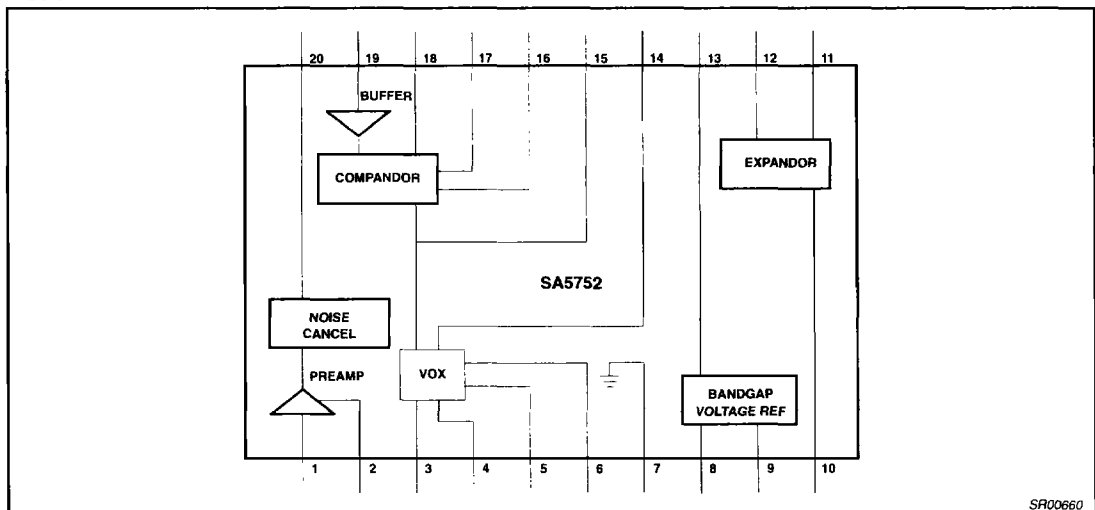

Figure 2. Block Diagram

SR00660

## Audio processor – companding, VOX and amplifier section

SA5752

## ABSOLUTE MAXIMUM RATINGS

SYMBOL	PARAMETER	RATING	UNIT
V <sub>CC</sub>	Power supply voltage range	-0.3 to 6	V
V <sub>IN</sub>	Voltage applied to any other pin	-0.3 to (V <sub>CC</sub> +0.3)	V
T <sub>STG</sub>	Storage temperature	-65 to +150	°C
T <sub>A</sub>	Ambient operating temperature	-40 to +85	°C

## DC ELECTRICAL CHARACTERISTICS

T<sub>A</sub> = 25°C, V<sub>CC</sub> = +3.0V, 0dB = 77.5mV<sub>RMS</sub>. See test circuit, Figure 6.

SYMBOL	PARAMETER	TEST CONDITIONS	LIMITS			UNIT
			MIN	TYP	MAX	
V <sub>CC</sub>	Supply voltage		2.7 <sup>4</sup>	3.0	5.5	V
I <sub>CC</sub>	Supply current	No signal Power down mode		3.1 125	4.0	mA µA
Z <sub>L</sub>	Load impedance pins NCAN <sub>OUT</sub> , EXP <sub>OUT</sub>		50			kΩ
	COMP <sub>OUT</sub> <sup>1</sup>		10			kΩ
Z <sub>IN</sub>	Input impedance COMP <sub>IN</sub> , MIC <sub>IN</sub>		40	50	60	kΩ
	EXP <sub>IN</sub> <sup>2</sup>		2.0			kΩ
	Noise cancellation current	Pin 6		25		µA
V <sub>OS</sub>	DC offset NCAN <sub>OUT</sub> <sup>3</sup>		-50	-3.0	50	mV

## NOTES:

- Compressor is tested in production with 50kΩ load.
- Not tested in production.
- Offset values are identical for both gain states of noise reduction circuit.
- Operational down to V<sub>DC</sub> = 2V

## AC ELECTRICAL CHARACTERISTICS

T<sub>A</sub> = 25°C, V<sub>CC</sub> = +3.0V, 0dB level = 77.5mV<sub>RMS</sub>. See test circuit, Figure 6.

SYMBOL	PARAMETER	TEST CONDITIONS	LIMITS			UNIT
			MIN	TYP	MAX	
	Preamplifier gain range		0		40	dB
	Preamplifier voltage gain 0dB	Pin 2 open	-1.0	0	1.0	dB
	Preamplifier voltage gain 40dB	Pin 2 AC ground	39.0	40	41.0	dB
	Preamplifier noise density	Pin 2 AC grounded RS = 50kΩ unweighted 20Hz-20kHz		7		nV/√Hz
		weighted CCIR DIN45405 20-20kHz		8		nV/√Hz
	Switch amplifier gain		9	10	11	dB
<b>Compandor 1kHz, all tests<sup>1</sup></b>						
COMP <sub>OUT</sub>	Compressor error at -21dB output level	Input level = -42dB	-1.0	-0.16	1.0	dB
COMP <sub>OUT</sub>	Compressor error at -10dB output level	Input level = -20dB	-1.0	-0.11	1.0	dB
COMP <sub>OUT</sub>	Compressor error at 0dB output level	Input level = 0dB	-1.5	+0.1	1.5	dB
COMP <sub>OUT</sub>	Compressor error at +5dB output level	Input level = +10dB	-1.0	+0.04	1.0	dB
COMP <sub>OUT</sub>	Compressor error at +10dB output level	Input level = +20dB	-1.0	+0.02	1.0	dB
EXP <sub>OUT</sub>	Expander error at -42dB output level	Input level = -21dB	-1.0	-0.12	1.0	dB
EXP <sub>OUT</sub>	Expander error at -21dB output level	Input level = -10.5dB	-1.0	+0.1	1.0	dB
EXP <sub>OUT</sub>	Expander error at -10dB output level	Input level = -5dB	-1.0	+0.03	1.0	dB

## Audio processor – companding, VOX and amplifier section

SA5752

## AC ELECTRICAL CHARACTERISTICS (Continued)

SYMBOL	PARAMETER	TEST CONDITIONS	LIMITS			UNIT
			MIN	TYP	MAX	
EXP <sub>OUT</sub>	Expander error at 0dB output level	Input level = 0dB	-1.5	-0.2	1.5	dB
EXP <sub>OUT</sub>	Expander error at +10dB output level	Input level = +5dB	-1.0	+0.03	1.0	dB
EXP <sub>OUT</sub>	Expander error at +20dB output level <sup>2</sup>	Input level = +10dB	-1.0	-0.1	1.0	dB
EXP <sub>OUT</sub>	Expander V <sub>OS</sub>	No signal	-50.0	+3.0	50.0	mV
EXP <sub>OUT</sub>	Expander output DC shift	No signal to 0dB	-100	+2.0	100	mV
	Timing capacitors compandor			2200		nF
THD	Total harmonic distortion					
	Compressor	1kHz, 0dB BW=300-3kHz		0.2	1	%
	Expander	1kHz, 0dB BW=300-3kHz		0.1	1	%
	NCAN <sub>OUT</sub>	1kHz, Pin 2 open output level = 0dB			0.02	1
1kHz, Pin 2 open output level = +20dB				0.06	1	%
VOX <sub>OUT</sub>	Sink current				0.5	mA
	Low level High level	Open collector i <sub>L</sub> = 0.5mA		V <sub>CC</sub>	0.4	V V
VOX <sub>CTL</sub>	Input current	Low	-50	-6.6	0	μA
		High	-10	-0.02	+10	μA
	Input level	Low	0		0.3V <sub>CC</sub>	V
High		0.7V <sub>CC</sub>		V <sub>CC</sub>	V	
HPDN	Input current	Low	-10	-4.1	+10	μA
		High	-10	-0.2	+10	μA
	Input level	Low	0		0.3V <sub>CC</sub>	V
High		0.7V <sub>CC</sub>		V <sub>CC</sub>	V	
	Reference filter capacitor			10		μF

## NOTE:

1. Measurements are relative to 0dB output.
2. Measurement is indicative of the output dynamic range capability.

Audio processor – companding, VOX and amplifier section

SA5752

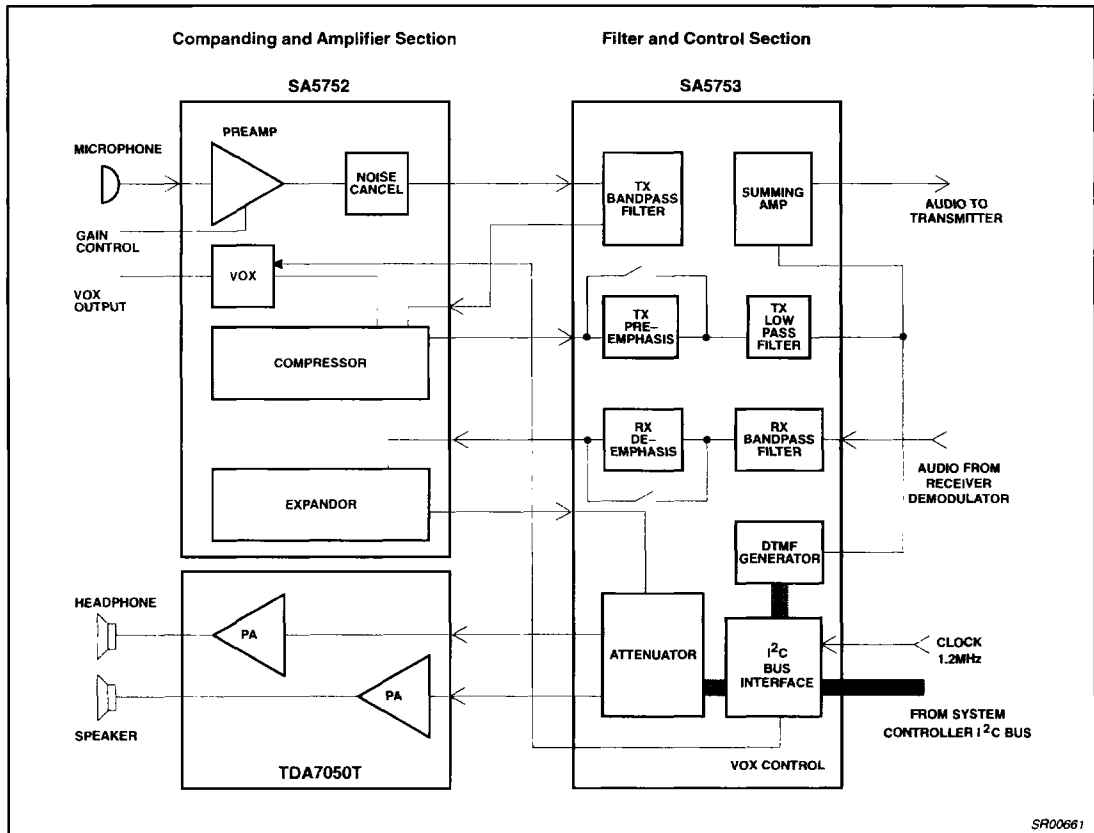
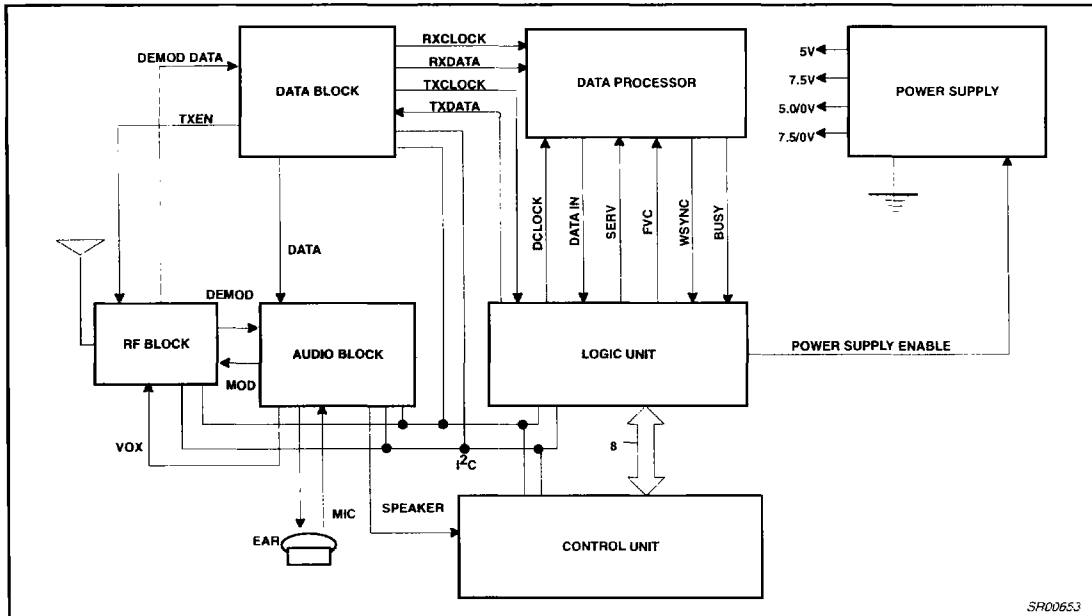

Figure 3. Typical Configuration of Audio Processor (APROC) System Chip Set

Audio processor – companding, VOX and amplifier section

SA5752



SR00653

Figure 4. Cellular Radio System

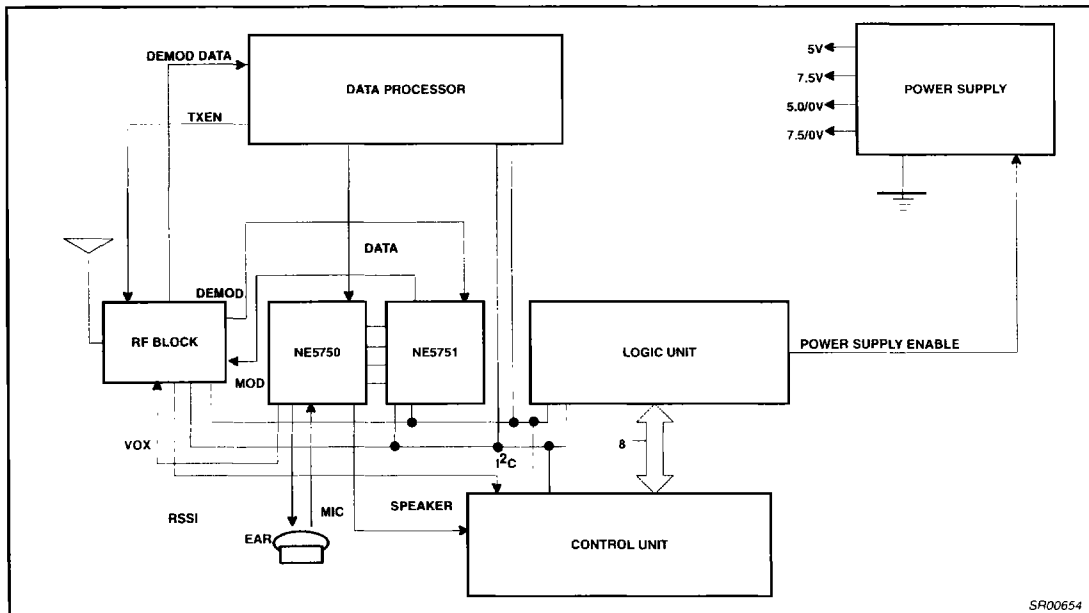

SR00654

Figure 5. APROC Application Diagram

Audio processor – companding, VOX and amplifier section

SA5752

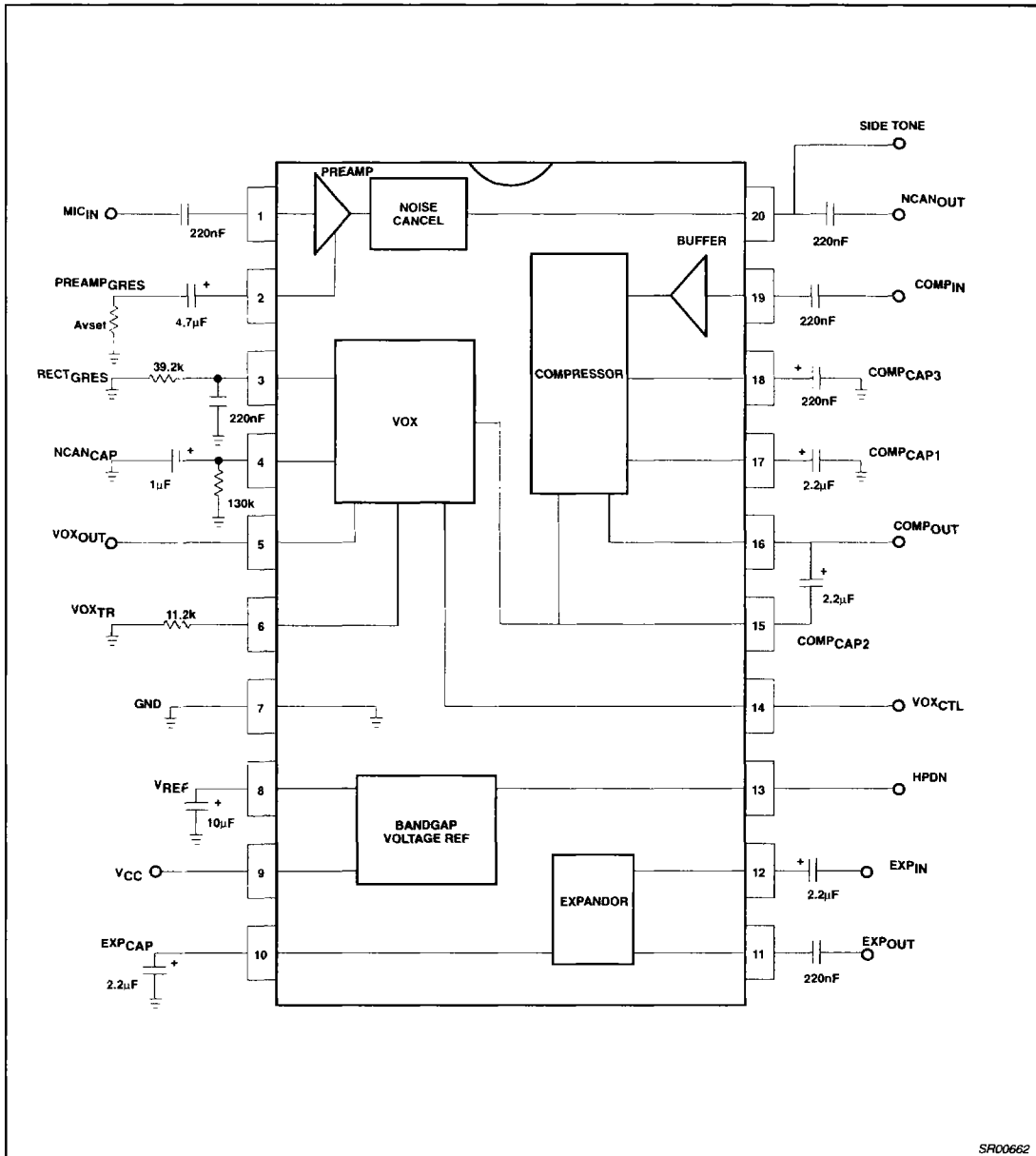

Figure 6. SA5752 Test and Application Circuit

SR00662

Audio processor – companding, VOX and amplifier section

SA5752

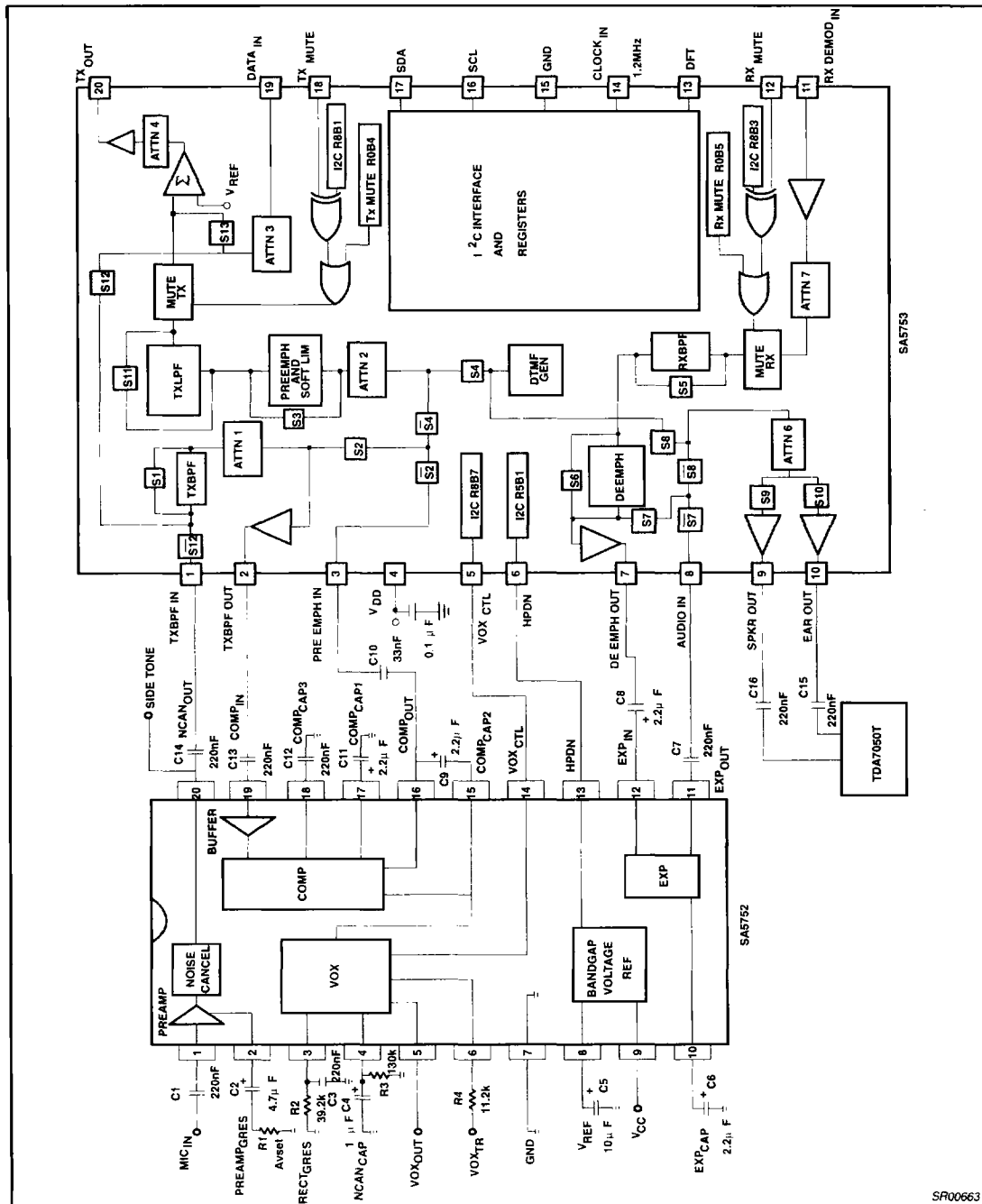

Figure 7. Application Diagram for the Audio Processor



Audio processor – companding, VOX and amplifier section

SA5752

TYPICAL PERFORMANCE CHARACTERISTICS

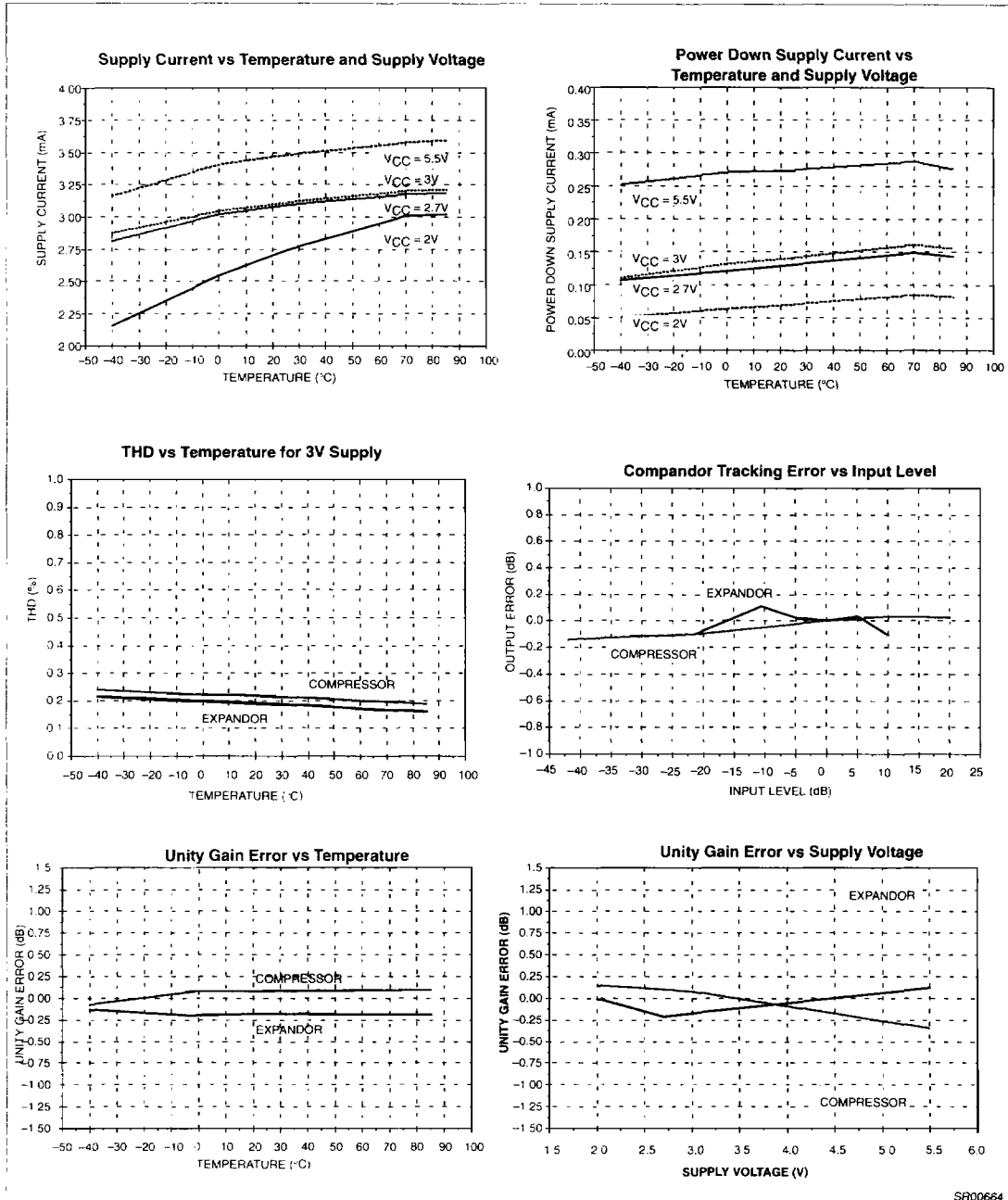

SR00664

Figure 8. Typical Performance Characteristics

Audio processor – companding, VOX and amplifier section

SA5752

TYPICAL PERFORMANCE CHARACTERISTICS (Continued)

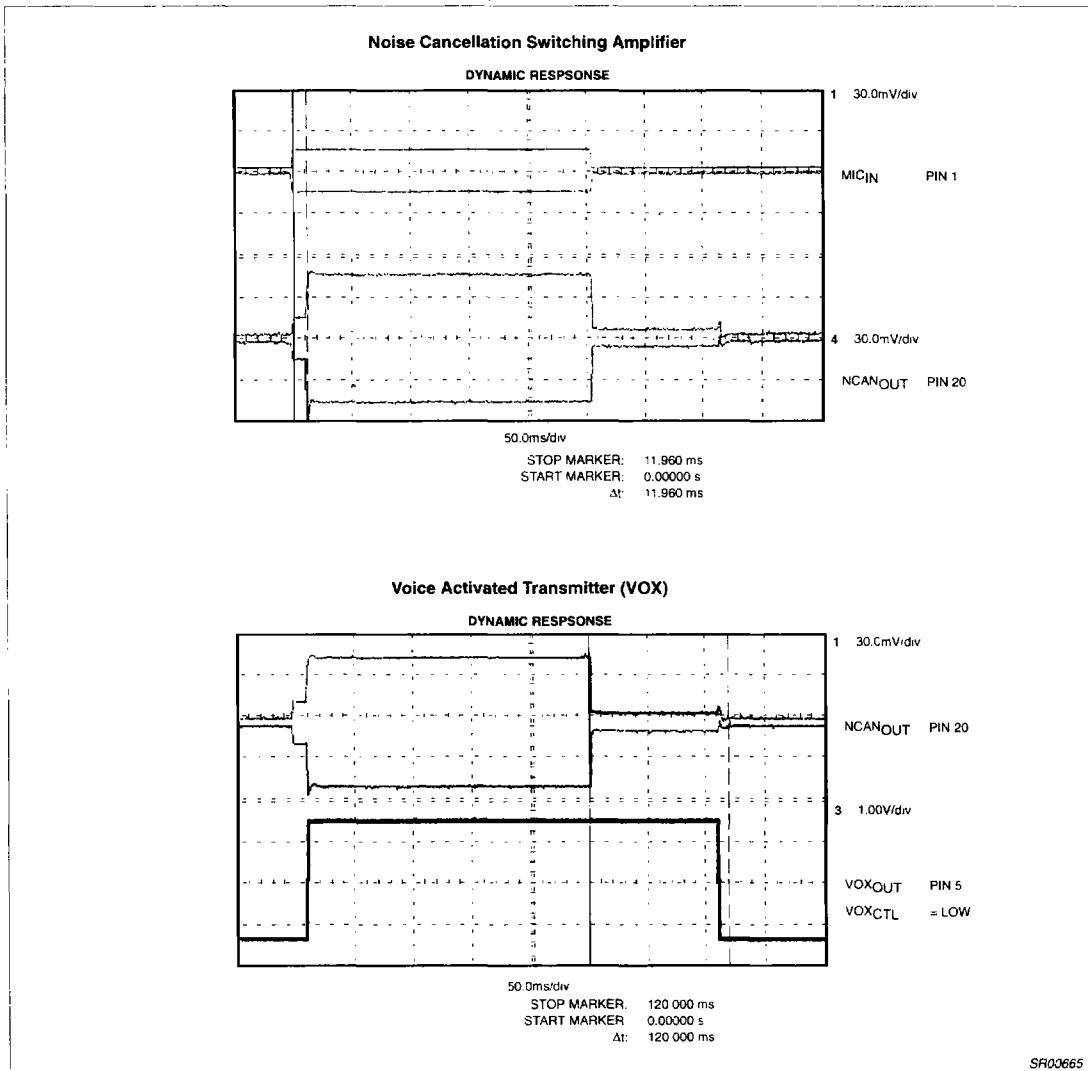

Figure 9. Typical Performance Characteristics (cont.)