Ordering Information

MF431	TO-46 Package
MF431 ST	ST Housing
MF431 SC	SC Housing
MF431 SMA	SMA Housing
MF431 FC	FC Housing

-40°C to +85°C

Note: Rated Fiber coupled power apply only on the TO-46 package, for housing options fiber coupled power is typically 10% less.

Description

This LED is designed for Datacom, Telecom and General Purpose Applications. It has a long wavelength LED for links up to 10 km at 125 Mbps. It meets standards for FDDI (ANSI X3T9.5) and ATM 155 Mbps. The device is optimized for 62.5/125 μm fiber and actively aligned in an ST receptacle. The MF432 PIN Photodiode is recommended as Receiver for this LED.

Features

- 1320 nm Surface-Emitting LED
- 125 MHz Bandwidth
- Designed for 62.5/125 μm Fiber
- Aligned in Multiple Receptacle
- MTTF >1,000,000 hours

Applications

- Sonet OC-3
- FDDI
- ATM 155 Mbps
- General Purpose

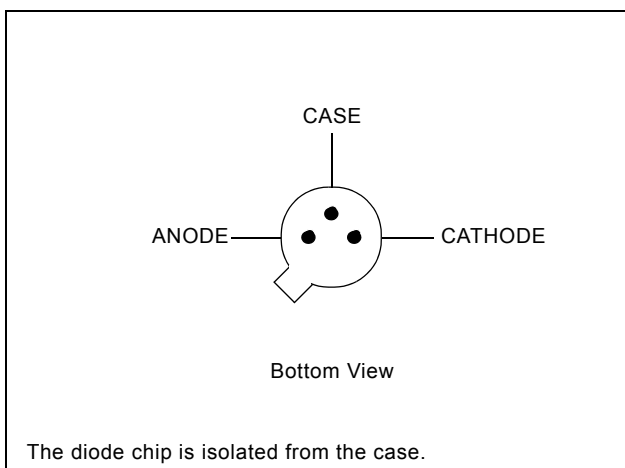
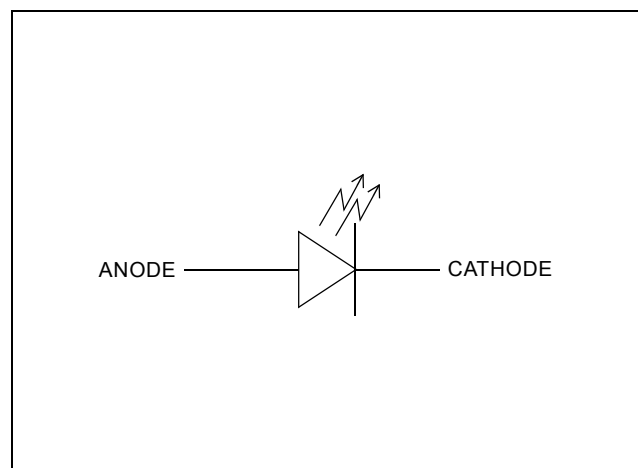
Figure 1 - Pin Diagram

Figure 2 - Functional Schematic

Optical and Electrical Characteristics - Case Temperature 25 °C

Parameter	Symbol	Min.	Typ.	Max.	Unit	Test Condition	
Fiber-Coupled Power (Figures 3, 4, and 5) (Table 1)	P_{fiber}	43			μW	$I_F=60\text{ mA}$ (Note 1)	Fiber: 62.5/125 μm Graded Index
Rise and Fall Time (10-90%)	t_r, t_f		2.5		ns	$I_F=60\text{ mA}$ (no bias)	
Bandwidth (3dB _{e1})	f_c		125		MHz	$I_F=60\text{ mA}$	
Peak Center Wavelength	λ_p		1320		nm	$I_F=60\text{ mA}$	
Spectral Width (FWHM)	$\Delta\lambda$		135		nm	$I_F=60\text{ mA}$	
Forward Voltage (Figure 7)	V_F		1.3	1.65	V	$I_F=60\text{ mA}$	
Reverse Current	I_R			100	μA	$V_R=1\text{ V}$	
Capacitance	C		200		pF	$V_R=0\text{ V}, f=1\text{ MHz}$	

Note 1: Measured at the exit of 100 meters of fiber.

Absolute Maximum Ratings

Parameter	Symbol	Limit
Storage Temperature	T_{stg}	-55 to +125 °C
Operating Temperature (derating: Figure 6)	T_{op}	-40 to +85 °C
Electrical Power Dissipation (derating: Figure 6)	P_{tot}	160 mW
Continuous Forward Current (f<10 kHz)	I_F	80 mA
Peak Forward Current (duty cycle<50%, f>1 MHz)	I_{FRM}	130 mA
Reverse Voltage	V_R	0.5 V
Soldering Temperature (2 mm from the case for 10 sec.)	T_{slid}	260 °C

Thermal Characteristics

Parameter	Symbol	Min.	Typ.	Max.	Unit
Thermal Resistance - Infinite Heat Sink	R_{thjc}			150	°C/W
Thermal Resistance - No Heat Sink	R_{thja}			400	°C/W
Temperature Coefficient - Optical Power	dP/dT_j		-0.75		%/°C
Temperature Coefficient - Wavelength	$\Delta\lambda/dT_j$		0.45		nm/°C



Figure 3 - Relative Fiber-coupled Power vs. z - Axial Displacement of Fiber



Figure 4 - Relative Fiber-coupled Power vs. r - Radial Displacement of Fiber

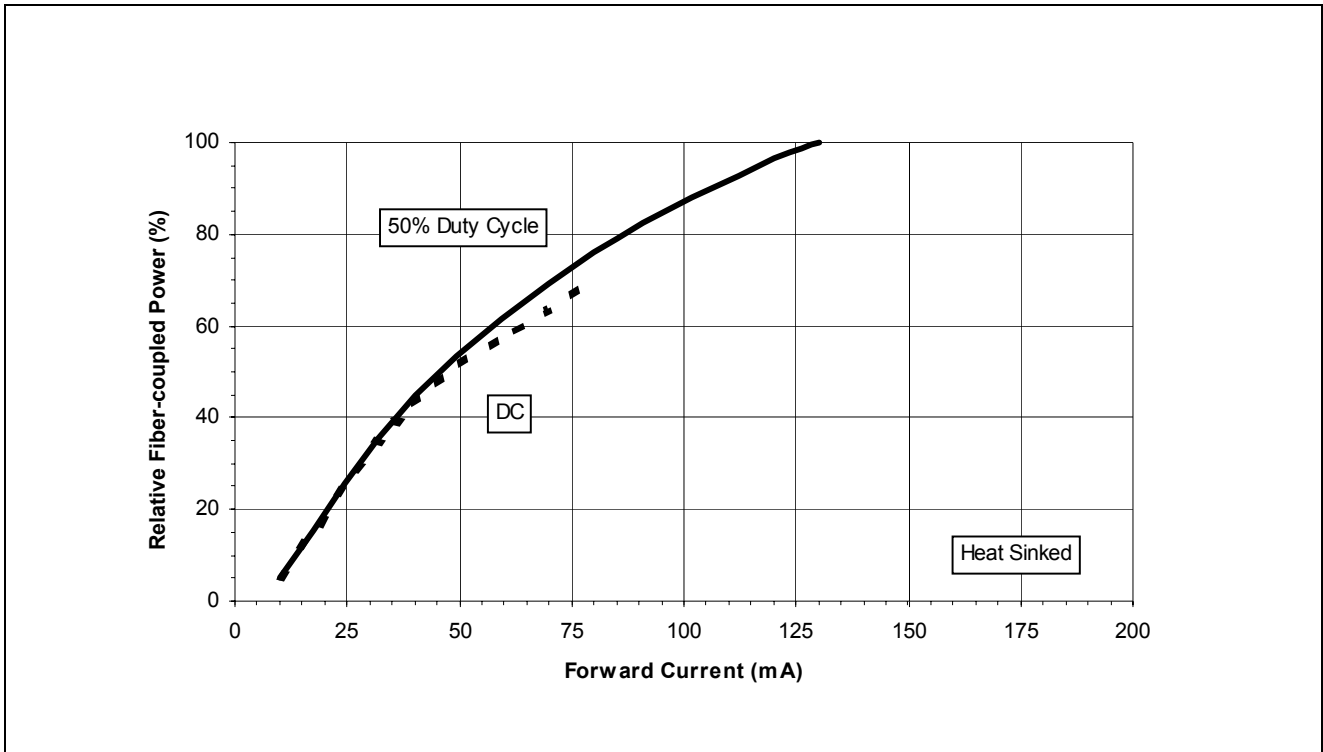

Figure 5 - Relative Fiber-coupled Power vs. Forward Current

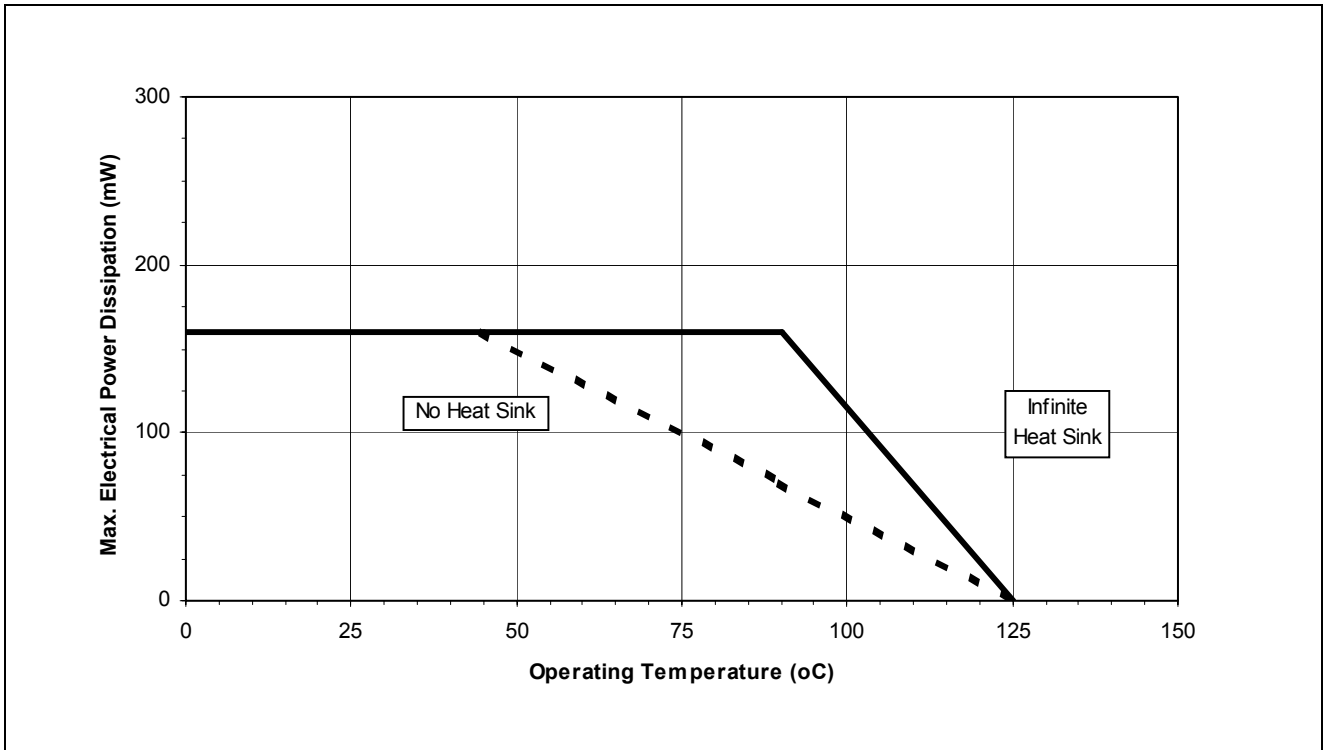

Figure 6 - Max. Electrical Power Dissipation vs. Operating Temperature

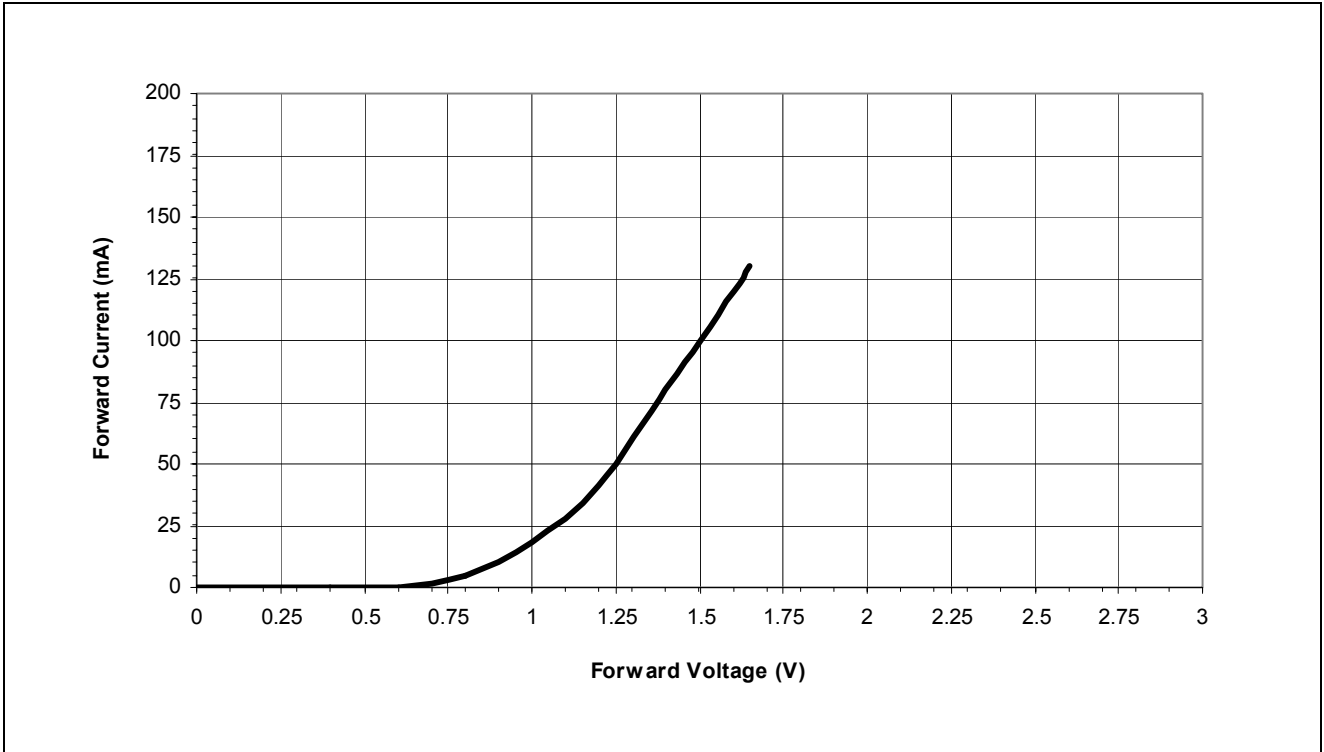
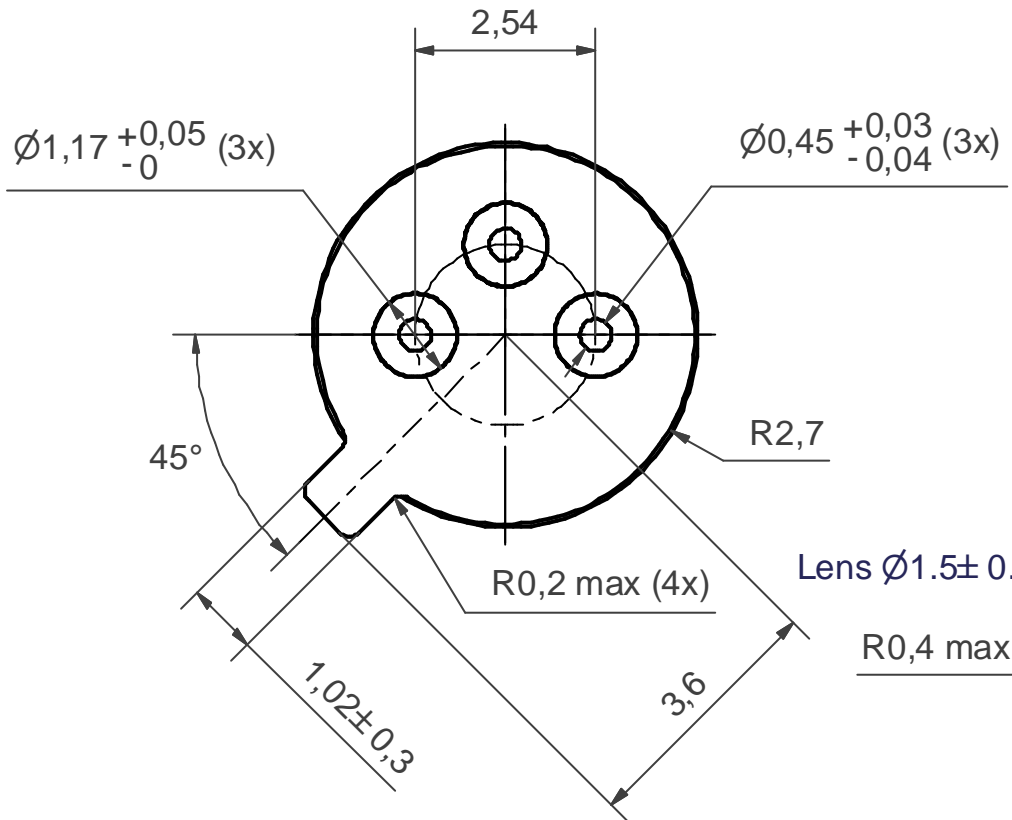
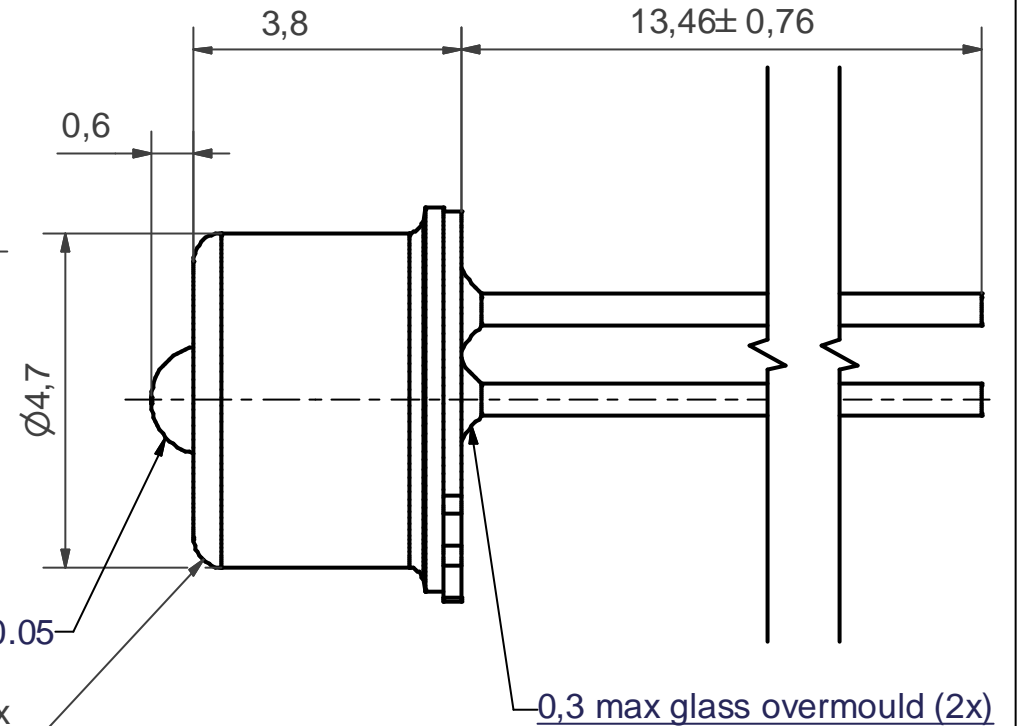

Figure 7 - Forward Current vs. Forward Voltage

BOTTOM VIEW (10 : 1)



SIDE VIEW



NOTES:-

1. All dimensions in mm.
2. General tol. ISO-2768-mK.
3. Coating: Case: Ni 1,5-2,5 μ m.
Header: Ni 2-3 μ m / Au min 1,32 μ m.

© Zarlink Semiconductor 2002. All rights reserved.

ISSUE	1			
ACN	JS004076R1A			
DATE	22-MAR-03			
APPRD.	TD/BE			



	Package code TB
Previous package codes	Drawing type Package drawing, TO-46 with lens
	Title JS004076



**For more information about all Zarlink products
visit our Web Site at
www.zarlink.com**

Information relating to products and services furnished herein by Zarlink Semiconductor Inc. or its subsidiaries (collectively "Zarlink") is believed to be reliable. However, Zarlink assumes no liability for errors that may appear in this publication, or for liability otherwise arising from the application or use of any such information, product or service or for any infringement of patents or other intellectual property rights owned by third parties which may result from such application or use. Neither the supply of such information or purchase of product or service conveys any license, either express or implied, under patents or other intellectual property rights owned by Zarlink or licensed from third parties by Zarlink, whatsoever. Purchasers of products are also hereby notified that the use of product in certain ways or in combination with Zarlink, or non-Zarlink furnished goods or services may infringe patents or other intellectual property rights owned by Zarlink.

This publication is issued to provide information only and (unless agreed by Zarlink in writing) may not be used, applied or reproduced for any purpose nor form part of any order or contract nor to be regarded as a representation relating to the products or services concerned. The products, their specifications, services and other information appearing in this publication are subject to change by Zarlink without notice. No warranty or guarantee express or implied is made regarding the capability, performance or suitability of any product or service. Information concerning possible methods of use is provided as a guide only and does not constitute any guarantee that such methods of use will be satisfactory in a specific piece of equipment. It is the user's responsibility to fully determine the performance and suitability of any equipment using such information and to ensure that any publication or data used is up to date and has not been superseded. Manufacturing does not necessarily include testing of all functions or parameters. These products are not suitable for use in any medical products whose failure to perform may result in significant injury or death to the user. All products and materials are sold and services provided subject to Zarlink's conditions of sale which are available on request.

Purchase of Zarlink's I²C components conveys a licence under the Philips I²C Patent rights to use these components in and I²C System, provided that the system conforms to the I²C Standard Specification as defined by Philips.

Zarlink, ZL and the Zarlink Semiconductor logo are trademarks of Zarlink Semiconductor Inc.

Copyright Zarlink Semiconductor Inc. All Rights Reserved.

TECHNICAL DOCUMENTATION - NOT FOR RESALE
