

## ADVANCED SPECIFICATION

## EL LAMP DRIVER WITH INTENSITY CONTROL

### FEATURES

- Designed for 40 nF to 80 nF Panel Capacitance
- Lamp Voltage Independent of Input Voltage and Temperature
- Lamp Frequency Independent of Input Voltage and Temperature
- High Ratio of Brightness / Input Power
- Constant Brightness Versus Input Supply Changes
- Panel Voltage Slew Rates Controlled for Life Enhancement
- Single Intensity Control and Enable Pin
- Analog Intensity Control
- PWM Control Method (Lower RF Noise)
- Adjustable Output Voltage

### DESCRIPTION

The TK6594x Electroluminescent (EL) Lamp Driver has been optimized for battery powered systems where power consumption and driving large EL lamps (~50 cm<sup>2</sup> to 100 cm<sup>2</sup>) to high brightness are the primary concerns.

The proprietary architecture (detailed in the Theory of Operation section) of the TK6594x provides a constant output power to the lamp, independent of variations in the battery voltage. This architecture allows the output voltage to remain relatively constant as battery voltages decay, without the need for directly sensing the high voltage output of the EL driver.

The oscillator circuits for the boost converter and lamp driver are both internally generated in the TK6594x, without the need for external components. The clock frequency of the boost converter is laser-trimmed to ensure good initial accuracy that is relatively insensitive to variations in temperature and supply voltage. The clock frequency of the lamp driver tracks the frequency of the boost converter by a constant scaling factor.

### ORDERING INFORMATION

TK6594xM□□

└─ Tape/Reel Code  
└─ Lamp Frequency Code

TAPE/REEL CODE  
TL: Tape Left

### APPLICATIONS

- PDA/PCA
- Hand Held Devices
- Battery Powered Systems
- GPS Systems
- LCD Modules
- Cellular Telephones
- Consumer Electronics

Furthermore, the drive architecture of the TK6594x has been designed to control the current delivered to the lamp. This approach limits the slew rate of the voltage across the lamp and has the potential to improve lamp life and decrease RF interference.

An easy to use "Intensity Control" pin is available to dim the panel and reduce battery drain as well as provide better contrast control to the user. The same pin is also used to activate on/off (disable) control of the IC.

The TK6594x is available in the small MSOP-10 surface mount package.

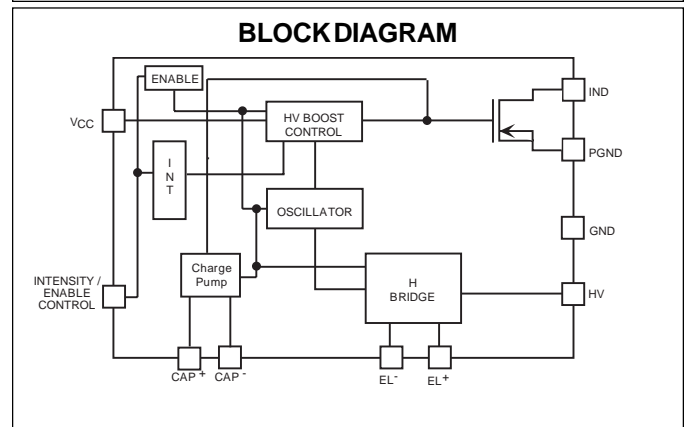
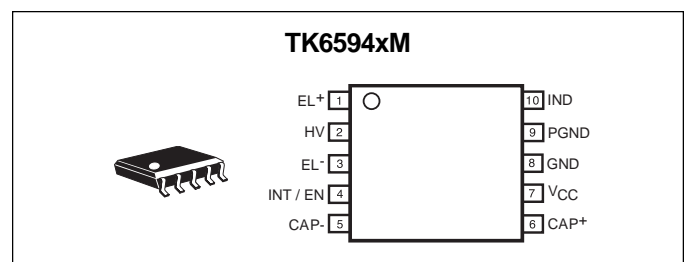

**ABSOLUTE MAXIMUM RATINGS**

$V_{CC}$ , CAP-, CAP+, DIM/DIS pins ..... 6.5 V  
 IND-, HV, EL-, EL+ pins .....  $V_{CLAMP}$   
 Power Dissipation (Note 1) ..... 1000 mW

Storage Temperature Range ..... -55 to +150 °C  
 Operating Temperature Range ..... -30 to +80 °C  
 Junction Temperature ..... 150 °C

**TK6594x ELECTRICAL CHARACTERISTICS**

$V_{CC} = 3.6$  V,  $T_A = T_J = 25$  °C, unless otherwise specified.

SYMBOL	PARAMETER	TEST CONDITIONS	MIN	TYP	MAX	UNITS
$V_{CC}$	Input Supply Range		2.0	3.6	6	V
$I_Q$	Quiescent Current	Current into $V_{CC}$ pin			1.2	mA
$I_{PEAK}$	Peak Current Threshold	INT/EN pin @ 1.8 V		250		mA
$R_{DS(on)}$	Main FET Resistance			4.0		$\Omega$
$F_{LAMP}$	Lamp Frequency		See Table 1			Hz
SR	$EL_{LAMP}$ Voltage Slew Rate	$F_{LAMP} = 250$ Hz $C_{LAMP} = 80$ nF (Note 3)		90		V/ms
		$F_{LAMP} = 250$ Hz $C_{LAMP} = 45$ nF (Note 3)		170		
		$F_{LAMP} = 450$ Hz $C_{LAMP} = 80$ nF (Note 3)		110		
		$F_{LAMP} = 450$ Hz $C_{LAMP} = 45$ nF (Note 3)		205		
		$F_{LAMP} = 700$ Hz $C_{LAMP} = 80$ nF (Note 3)		150		
		$F_{LAMP} = 700$ Hz $C_{LAMP} = 45$ nF (Note 3)		280		
$F_{BOOST}$	Boost Frequency		See Table 2			kHz
$V_{CLAMP}$	HV Clamp Voltage	Force 1mA into HVpin	120			V
$D_{(MAX)}$	Maximum Duty Cycle		88	92	96	%
$V_{OUT}$	Peak to Peak Lamp Voltage	(Note 3) @ 250Hz @ 450 Hz @ 700 Hz	185 159 129	200 172 140	215 185 151	V
$I_{CONV}$	Converter Supply Current	(Notes 2, 3)	See Table 3			mA
$V_{ENABLE}$	Full Intensity Enable Voltage Level		2.0		$V_{CC}$	V
$I_{STBY}$	Standby Current	$V_{INT/EN} < 0.3$ V		1		$\mu$ A
$V_{INT}$	Intensity Control Voltage Range		0.30		1.8	V
$I_{PEAK(MAX DIM)}$	Peak Current at (Max DIM)	INT / EN pin @ 0.4V		90		mA

Note 1: Power dissipation is 1000 mW when mounted as recommended. Derate at 8.0 mW/°C for operation above 25 °C.

Note 2: Converter supply current is dependent upon the DC resistance of inductor  $L_1$ . Lower DC resistances will result in lower supply currents.

Note 3: When using test circuit below.



## TK6594x ELECTRICAL CHARACTERISTICS

$V_{IN} = 3.6\text{ V}$ ,  $T_A = T_j = 25\text{ }^\circ\text{C}$ , unless otherwise specified.

TABLE 1: LAMP FREQUENCY

TOKO PART NO.	MIN.	TYP.	MAX.
TK65940	-	250 Hz	-
TK65941	-	300 Hz	-
TK65942	-	350 Hz	-
TK65943	-	400 Hz	-
TK65944	-	450 Hz	-
TK65945	-	500 Hz	-
TK65946	-	550 Hz	-
TK65947	-	600 Hz	-
TK65948	-	650 Hz	-
TK65949	-	700 Hz	-

TABLE 2: OSCILLATOR FREQUENCY

TOKO PART NO.	MIN.	TYP.	MAX.
TK65940	-	16.0 kHz	-
TK65941	-	19.2 kHz	-
TK65942	-	22.4 kHz	-
TK65943	-	25.6 kHz	-
TK65944	-	28.8 kHz	-
TK65945	-	32.0 kHz	-
TK65946	-	35.2 kHz	-
TK65947	-	38.4 kHz	-
TK65948	-	41.6 kHz	-
TK65949	-	44.8 kHz	-

TABLE 3: CONVERTER CURRENT

TOKO PART NO.	MIN.	TYP.	MAX.
TK65940	-	90 mA	-
TK65941	-	-	-
TK65942	-	-	-
TK65943	-	-	-
TK65944	-	110 mA	-
TK65945	-	-	-
TK65946	-	-	-
TK65947	-	-	-
TK65948	-	-	-
TK65949	-	130 mA	-

TYPICAL PERFORMANCE CHARACTERISTICS  
USING TEST CIRCUIT

TK65940 SLEW RATE ACROSS  
45 $\mu$ F PANEL (210V/mS) @ 5V VDD

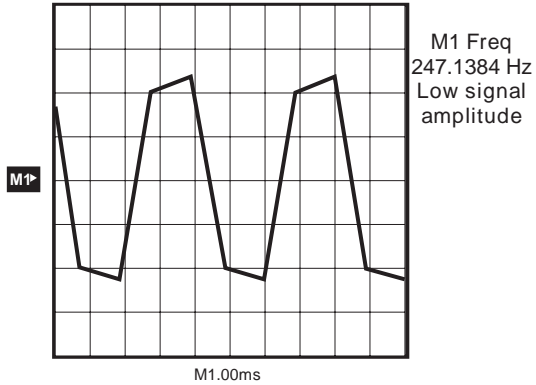

TK65949 SLEW RATE ACROSS  
45 $\mu$ F PANEL (276V/mS) @ 5V VDD

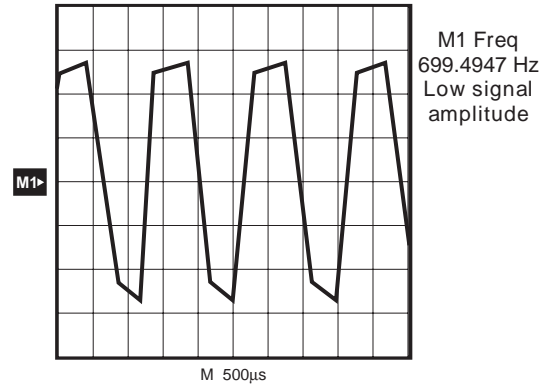

TK65940 PEAK TO PEAK LAMP  
VOLTAGE vs. SUPPLY VOLTAGE

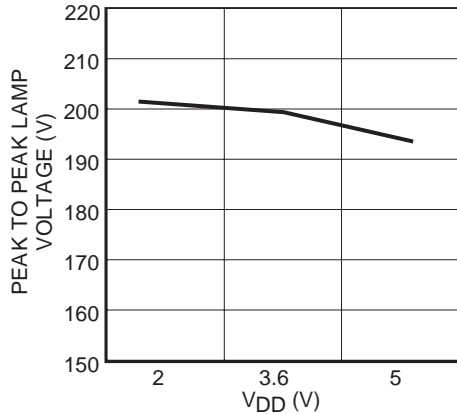

TK65949 PEAK TO PEAK LAMP  
VOLTAGE vs. SUPPLY VOLTAGE

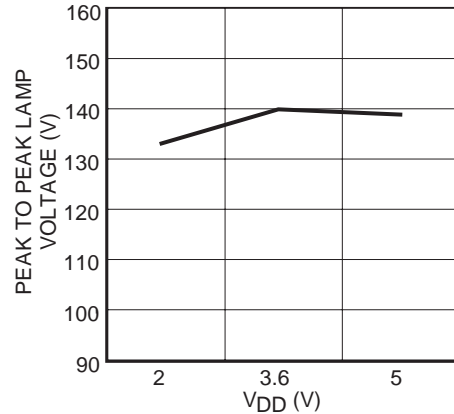

TK65940 LAMP FREQUENCY  
vs. SUPPLY VOLTAGE

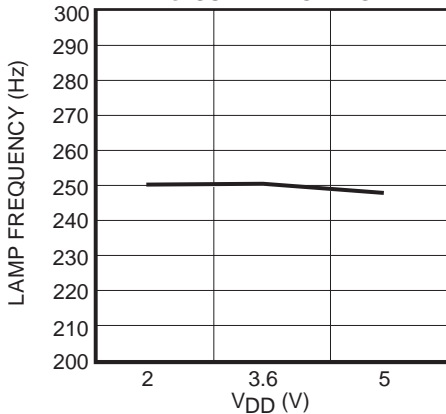

TK65949 LAMP FREQUENCY  
vs. SUPPLY VOLTAGE

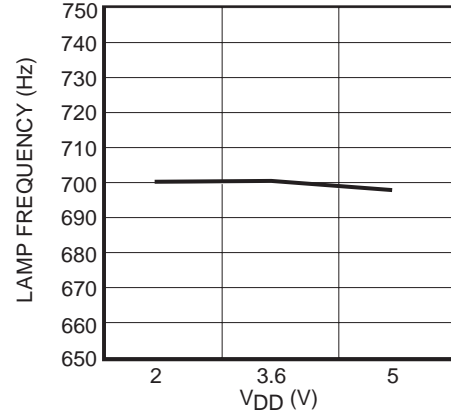

TYPICAL PERFORMANCE CHARACTERISTICS  
USING TEST CIRCUIT (CONT)

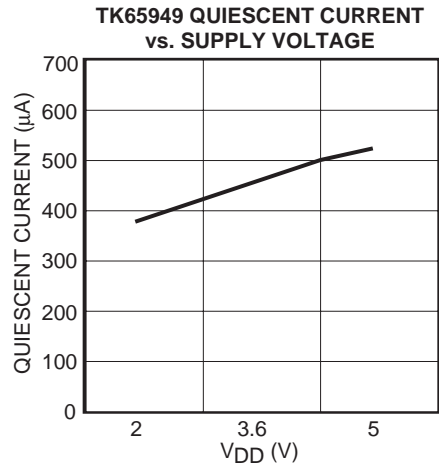
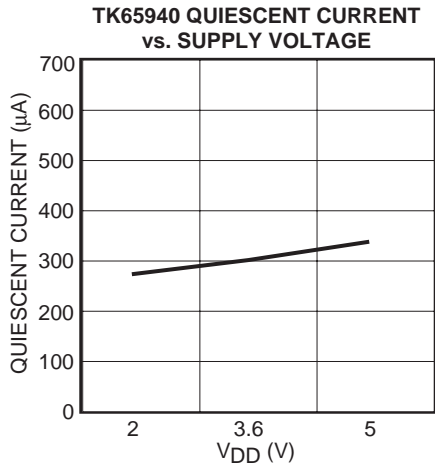
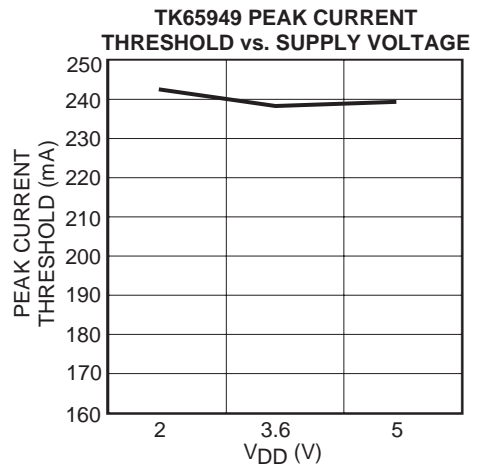
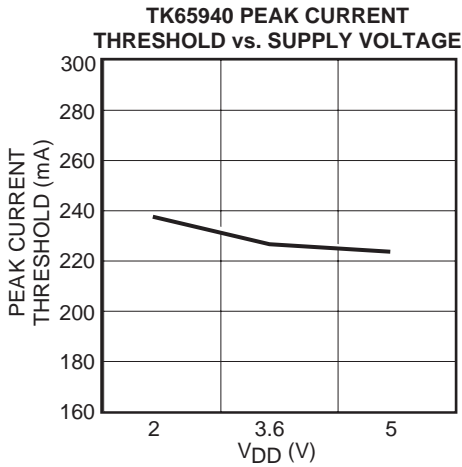
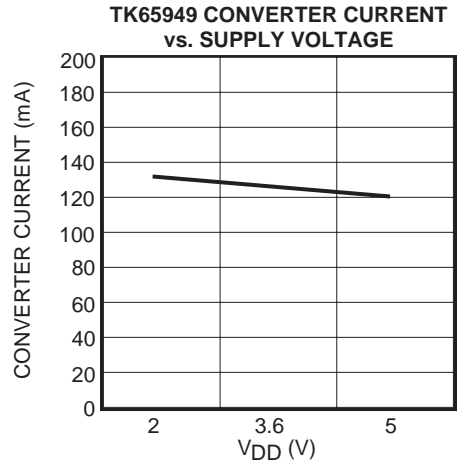
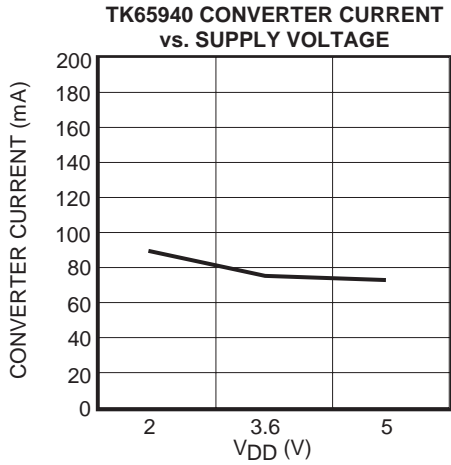

TYPICAL PERFORMANCE CHARACTERISTICS  
USING TEST CIRCUIT (CONT)

TK65940 PEAK CURRENT AT  
MAXIMUM DIM vs.  
SUPPLY VOLTAGE

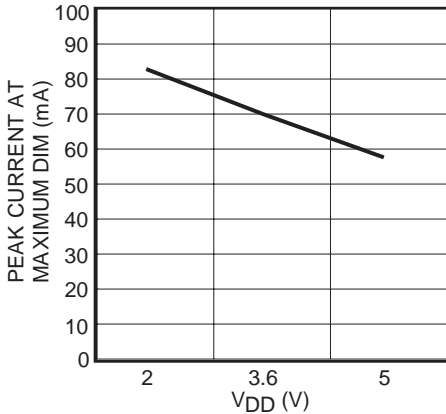

TK65949 PEAK CURRENT AT  
MAXIMUM DIM vs.  
SUPPLY VOLTAGE

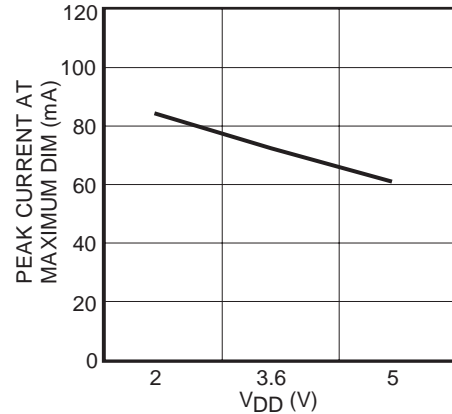

TK65940 STANDBY CURRENT  
vs. SUPPLY VOLTAGE

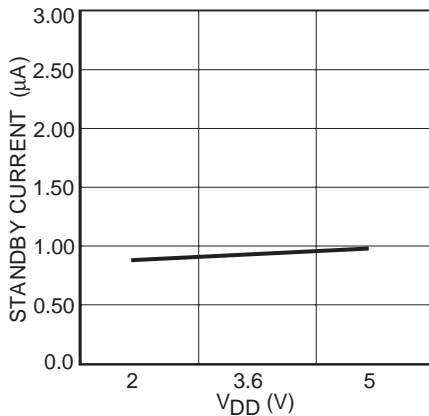

TK65949 STANDBY CURRENT  
vs. SUPPLY VOLTAGE

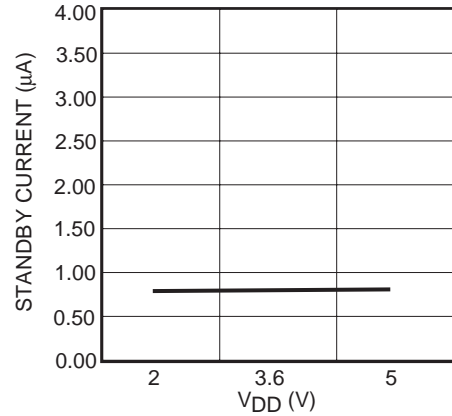

TK65940 PEAK TO PEAK LAMP  
VOLTAGE AT V<sub>DD</sub> = 3.6V  
vs. TEMPERATURE

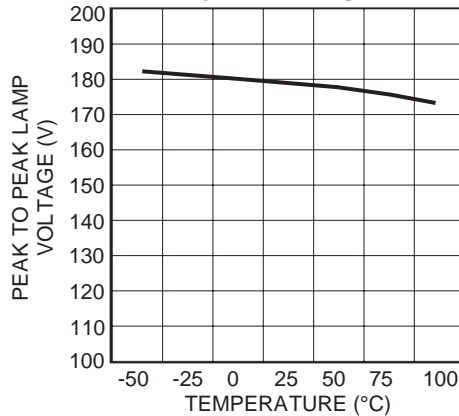

TK65949 PEAK TO PEAK LAMP  
VOLTAGE AT V<sub>DD</sub> = 3.6V  
vs. TEMPERATURE

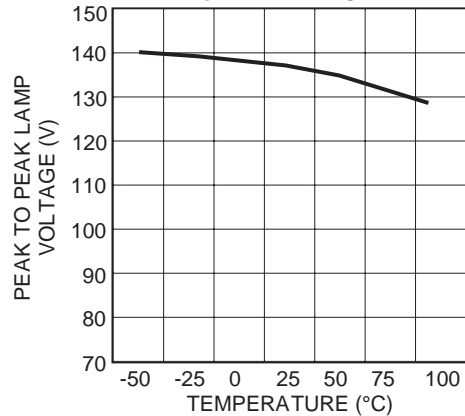

**TYPICAL PERFORMANCE CHARACTERISTICS  
USING TEST CIRCUIT (CONT)**

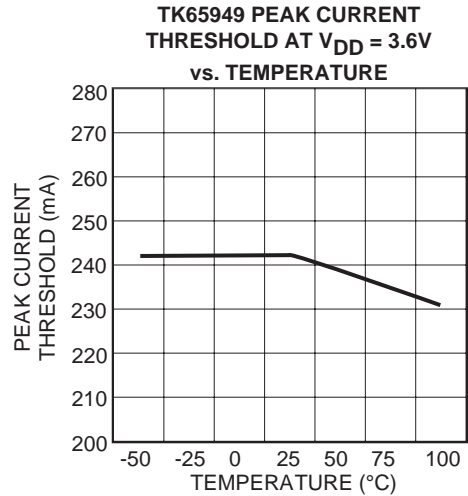
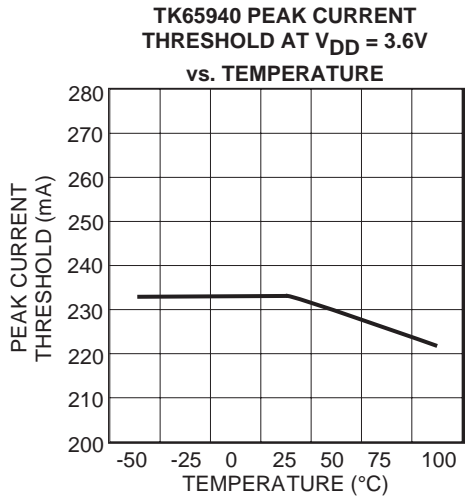
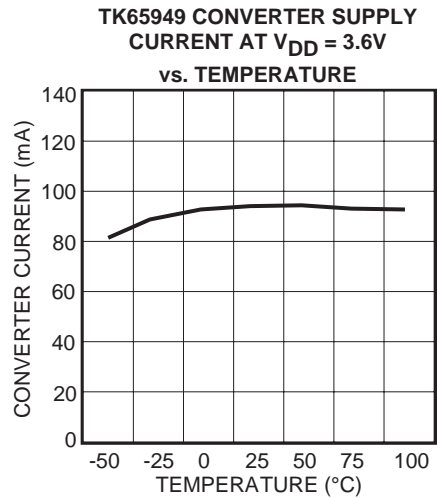
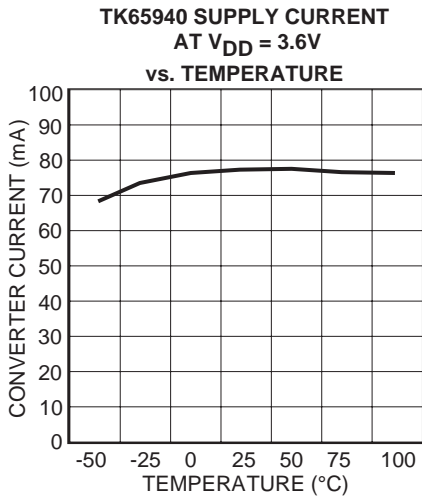
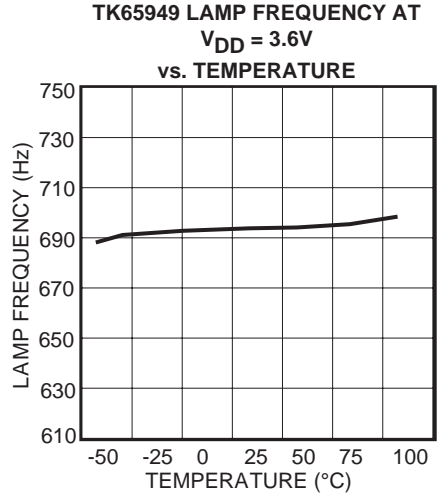
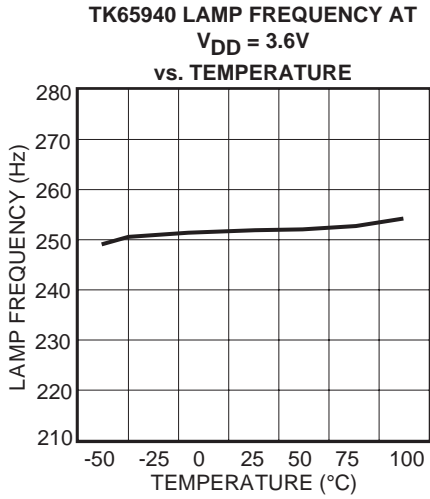

TYPICAL PERFORMANCE CHARACTERISTICS  
USING TEST CIRCUIT (CONT)

TK65940 QUIESCENT CURRENT  
THRESHOLD AT  $V_{DD} = 3.6V$   
vs. TEMPERATURE

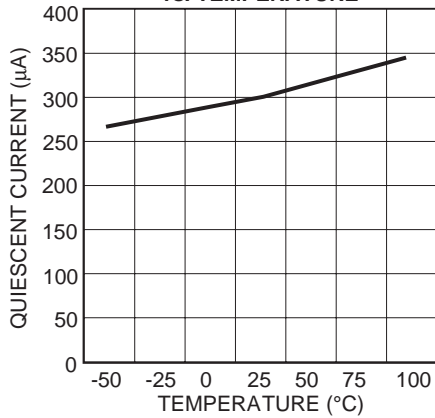

TK65949 QUIESCENT CURRENT  
AT  $V_{DD} = 3.6V$   
vs. TEMPERATURE

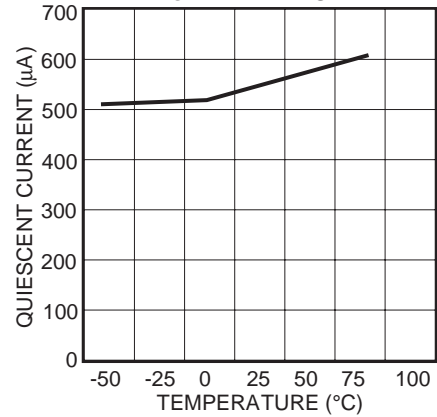

TK65940 STANDBY CURRENT  
AT  $V_{DD} = 3.6V$   
vs. TEMPERATURE

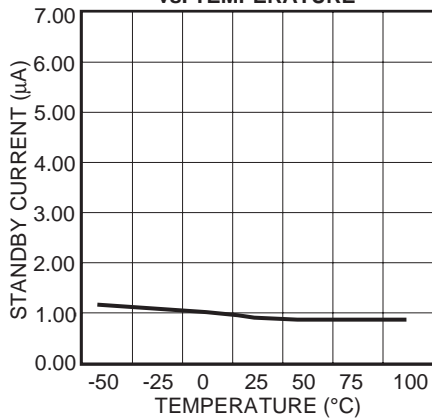

TK65949 STANDBY CURRENT  
AT  $V_{DD} = 3.6V$   
vs. TEMPERATURE

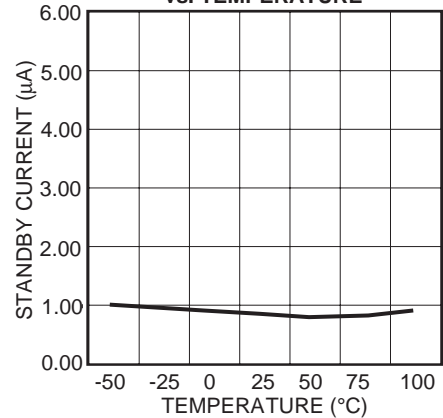

TK65940 PEAK CURRENT AT MAXI-  
MUM DIM vs. TEMPERATURE  
( $V_{DD} = 3.6V$ ) ( $V_{INT} = .4V$ )

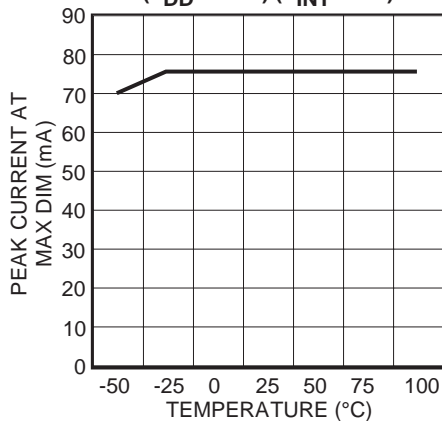

TK65949 PEAK CURRENT AT  
MAXIMUM DIM vs. TEMPERATURE  
( $V_{DD} = 3.6V$ ) ( $V_{INT} = .4V$ )

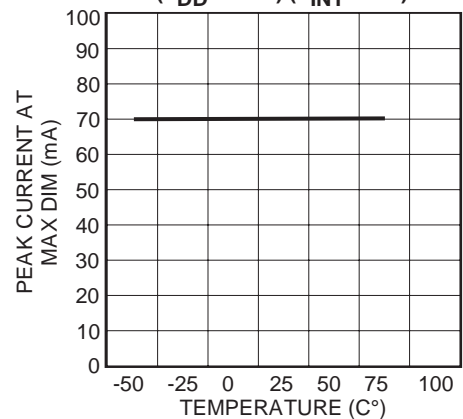

TYPICAL PERFORMANCE CHARACTERISTICS  
USING TEST CIRCUIT (CONT)

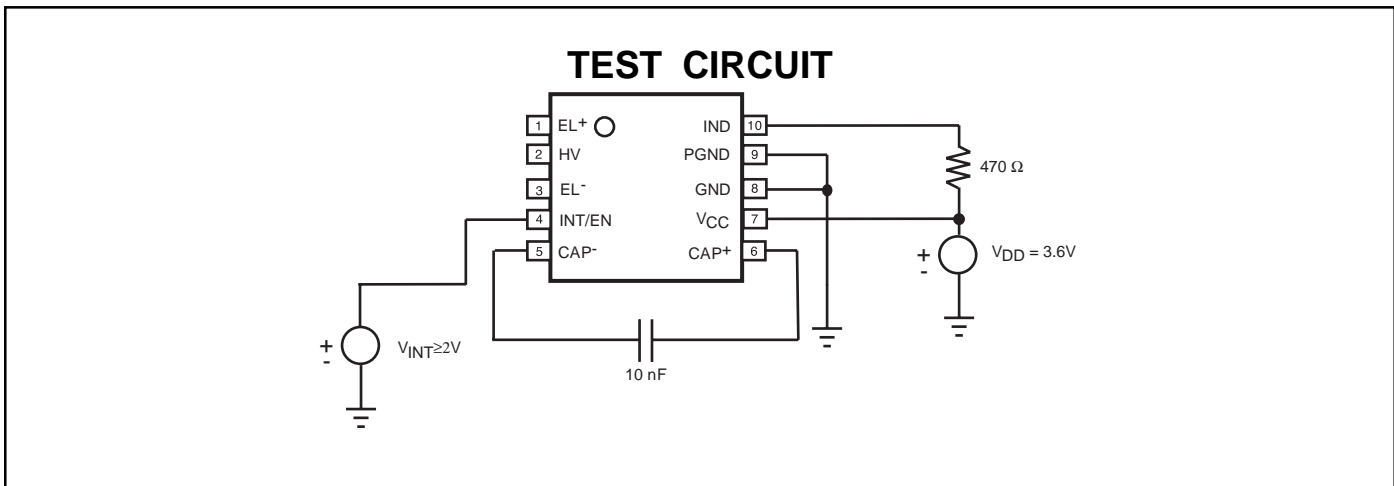
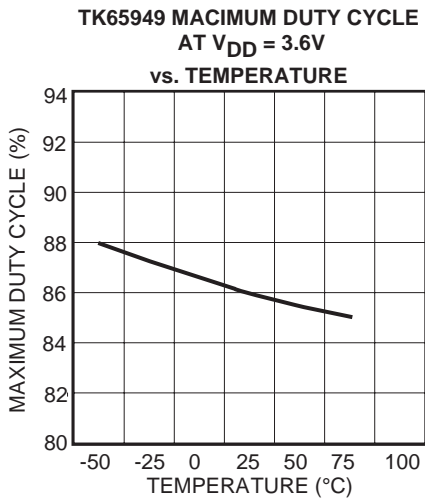
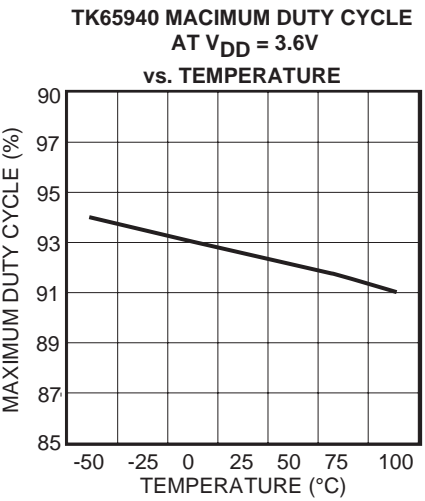
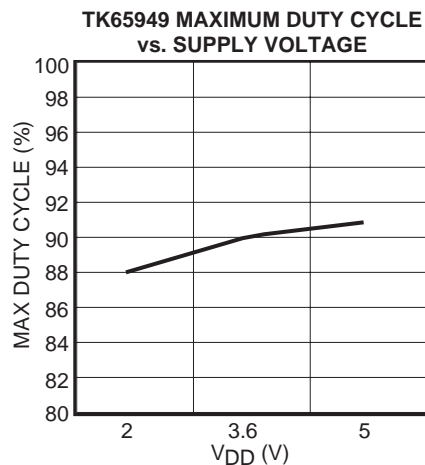
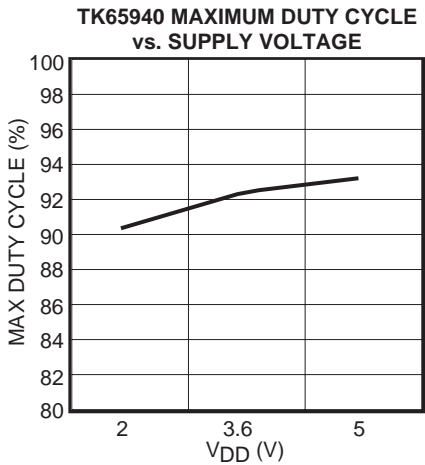

**THEORY OF OPERATION**

An Electroluminescent (EL) Lamp is a strip of plastic, coated with a phosphorous material that emits light when a high voltage AC signal is applied to the terminals of the device. EL panels have the ability to light the entire panel uniformly. Because of this, they are gradually becoming more popular and widespread than LEDs. The amount of light emitted from an EL Lamp is typically proportional to the magnitude of the voltage applied to the lamp. Furthermore, the color of the light emitted by an EL Lamp is somewhat dependent upon the frequency of the applied drive signal. For most applications, a peak-to-peak voltage of 100 to 170 V, with a drive frequency of 175 to 700 Hz, provides optimal trade-off between lamp intensity and power consumption.

The capacitance of the EL Panel is typically proportional to the size of the lamp (a 1 square inch EL Panel typically exhibits approximately 5 nF of capacitance load). The TK6594x series of devices has been optimized to drive EL panels, which are approximately 8-16 square inches in size.

The Boost section of the TK6594x consists of a controller for stepping up a relatively low voltage (2.0 to 6 V) to a much higher voltage (50 to 90 V) needed to drive the EL Lamp. The boost section of the TK6594x uses a proprietary architecture which provides a relatively constant output power, independent of the input supply, without the need for sensing the high voltage output of the boost converter. By controlling the peak current through the switching element of the boost converter, the boost section provides a constant output power independent of the input supply.

The H-Bridge section of the TK6594x switches the high voltage output of the boost converter to the two terminals of the EL Lamp. By alternately switching the terminals of the lamp between the high voltage supply and ground, the peak-to-peak voltage developed across the lamp is effectively twice the high voltage generated by boost converter. Furthermore, the TK6594x limits the magnitude of the drive currents through the H-Bridge switches in order to minimize the edge rates developed across the EL Lamp. This approach protects the EL Panel from large current spikes and reduces the likelihood of high frequency noise components being injected into neighboring circuitry.

The Oscillator section of the TK6594x generates a fixed frequency clock source for the previously described Boost and H-Bridge sections, without the need for external components. The high frequency output of the oscillator is used for driving the boost controller. A lower frequency

clock is generated by dividing the high frequency clock by 64; this lower frequency clock corresponds to the drive frequency of the EL Lamp. The laser-trimmed oscillators are relatively insensitive to variations in temperature and supply voltage. Therefore, they provide good control of the lamp color emitted by the panel.

The circuit below illustrates a typical application where the TK6594x is driving a 9-square-inch EL Lamp with a capacitance of approximately 45 nF.

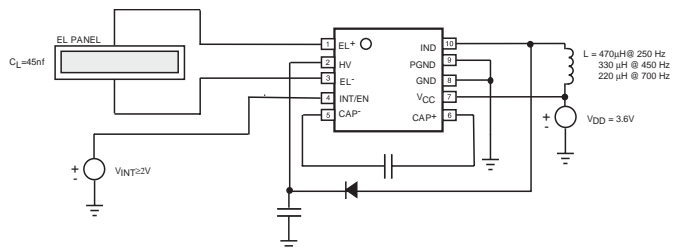

By keeping the ratio of the boost frequency and the H-Bridge frequency constant, the peak-to-peak output voltage from the TK6594x becomes primarily dependent upon the capacitance of the EL Lamp, the peak current threshold of the boost converter, and the value of the inductive element used in the boost converter. For the TK6594x, the peak current threshold is laser-trimmed to 250 mA. The capacitive load of the EL Lamp is a function of panel size and is typically fixed. Therefore, the high voltage output of the boost converter can be set to a desired voltage by selecting the appropriate value of the inductive element used in the boost converter.

$$I_{PEAK} = \text{Boost Peak Current Threshold (250 mA)}$$

$$C_{EL} = \text{Capacitance of EL Lamp}$$

$$L = \text{Inductance Value}$$

$$V_{HV} = (I_{PEAK} / 2) \times \sqrt{(L / C_{EL}) \times 64}$$

## THEORY OF OPERATION (CONT.)

With properly selected components, the TK6594x will nominally support peak output voltages to 100 V ( $200 V_{PK-PK}$ ). Should the EL Panel become disconnected from the driver outputs, the removal of the load can cause the output voltage to increase beyond 100 V. To protect against this fault condition, a clamp circuit exists on the high voltage output which nominally limits the output voltage to a typical value of 120 V ( $240 V_{PK-PK}$ ).

### DETAILS CONCERNING THE H-BRIDGE SECTION OPERATION

In an effort to extend EL lamp life, reduce EMI emissions, and reduce the power draw of the IC, current sources to control the charging and discharging of the EL lamp panel and special sequencing control of the H-bridge FETs were added to the H-bridge of TK6594x.

Current sources were added between ground and the sources of the low-side N-channel FETs (Figure 2). Therefore, the current into and out of the EL panel is controlled and limited.

The FETs are turned off and on in the sequence shown in Figure 3. As is noted in Figure 3, there is a period of time when both of lower N-channel FETs are turned on and both of upper P-channel FETs are turned off. **This provides a period of time to discharge the EL panel capacitance completely;** before starting to recharge it again with current from HV voltage rail. Therefore, this special sequencing method prevents taking current off the HV voltage rail during the discharge of EL panel capacitance and operates more efficiently.

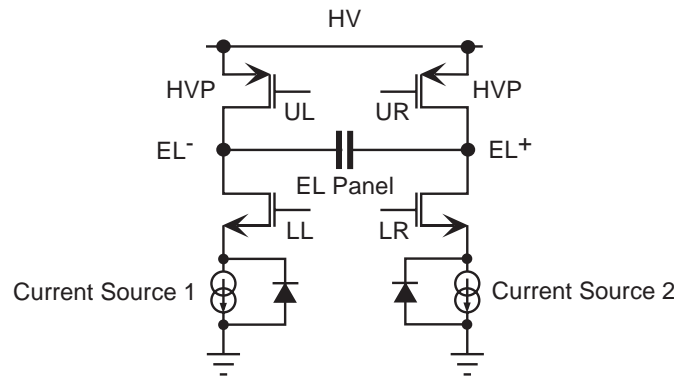

FIGURE 2: H-BRIDGE SCHEMATIC

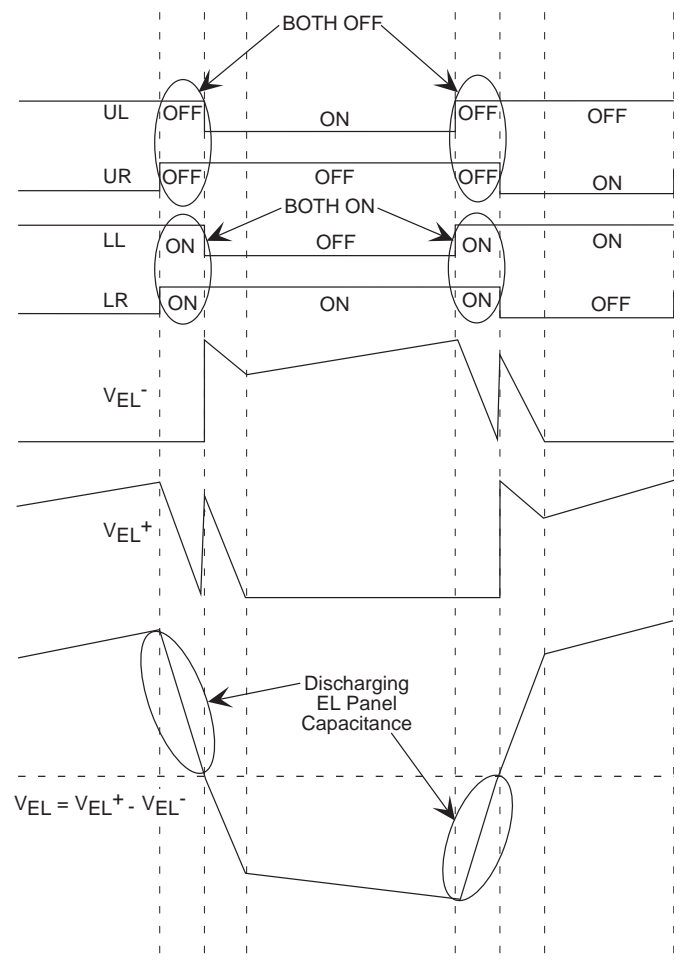

FIGURE 3: H-BRIDGE SEQUENCING WAVEFORMS

## DESIGN CONSIDERATIONS

### INDUCTOR VALUE SELECTION

Designing an EL Driver utilizing the TK6594x is a simple task. The primary component affecting the behavior of the converter is the inductor. Essentially, the entire design task primarily consists of selecting the proper inductor value and type given the operating conditions of the EL Panel (e.g., lamp capacitance, frequency, output voltage, supply range). The following tables and charts are intended to simplify the selection of the inductor.

For the boost converter to operate by regulating the peak current in the inductor as designed, the inductor value can not exceed a certain value for given circuit conditions of min. input voltage, max. resistance of the inductor and the internal boost MOSFET and max on-time.

$$\text{For the given RL circuit: } i = (1 - \exp(-\text{ton} * R / L)) * V_{IN} / R$$

$$\text{then solving for L under } I_P \text{ and max. ton: } L = (\text{max. ton}) * R / -\text{LN}(1 - I_P * R / V_{IN})$$

$$I_P = 250 \text{ mA} \quad \text{max. ton} = 0.9 / f \text{ converter} \quad R = R_L \text{ (the inductor resistance)} + 2.5 \Omega \text{ (the FET resistance)}$$

Table 4 contains the max. inductance value for a given min.  $V_{IN}$  and part # and inductor type Toko's D52FU, D62C, D73LFE.

**TABLE 4: MAX. INDUCTANCE VALUE VS. MIN  $V_{IN}$  AND PART FREQUENCY AND INDUCTOR TYPE**

PART NO. f lamp converter min. Vin	L type	TK65940	TK65941	TK65942	TK65943	TK65944	TK65945	TK65946	TK65947	TK65948	TK65949
		250 Hz 16.0 kHz	300 Hz 19.2 kHz	350 Hz 22.4 kHz	400 Hz 25.6 kHz	450 Hz 28.8 kHz	500 Hz 32.0 kHz	550 Hz 35.2 kHz	600 Hz 38.4 kHz	650 Hz 41.6 kHz	700 Hz 44.8 kHz
2V	D52FU	130 $\mu$ H	130 $\mu$ H	130 $\mu$ H	130 $\mu$ H	130 $\mu$ H	130 $\mu$ H	120 $\mu$ H	120 $\mu$ H	100 $\mu$ H	100 $\mu$ H
	D62C	270 $\mu$ H	270 $\mu$ H	200 $\mu$ H	180 $\mu$ H	180 $\mu$ H	150 $\mu$ H	150 $\mu$ H	120 $\mu$ H	120 $\mu$ H	120 $\mu$ H
	D73LFE	220 $\mu$ H	220 $\mu$ H	220 $\mu$ H	150 $\mu$ H	150 $\mu$ H	150 $\mu$ H	120 $\mu$ H	120 $\mu$ H	120 $\mu$ H	100 $\mu$ H
2.4V	D52FU	130 $\mu$ H	130 $\mu$ H	130 $\mu$ H	130 $\mu$ H	130 $\mu$ H	130 $\mu$ H	130 $\mu$ H	130 $\mu$ H	130 $\mu$ H	130 $\mu$ H
	D62C	270 $\mu$ H	270 $\mu$ H	270 $\mu$ H	220 $\mu$ H	220 $\mu$ H	200 $\mu$ H	180 $\mu$ H	150 $\mu$ H	150 $\mu$ H	150 $\mu$ H
	D73LFE	330 $\mu$ H	220 $\mu$ H	220 $\mu$ H	220 $\mu$ H	220 $\mu$ H	150 $\mu$ H	150 $\mu$ H	150 $\mu$ H	150 $\mu$ H	120 $\mu$ H
2.7V	D52FU	130 $\mu$ H	130 $\mu$ H	130 $\mu$ H	130 $\mu$ H	130 $\mu$ H	130 $\mu$ H	130 $\mu$ H	130 $\mu$ H	130 $\mu$ H	130 $\mu$ H
	D62C	270 $\mu$ H	270 $\mu$ H	270 $\mu$ H	270 $\mu$ H	220 $\mu$ H	200 $\mu$ H	200 $\mu$ H	180 $\mu$ H	150 $\mu$ H	150 $\mu$ H
	D73LFE	390 $\mu$ H	330 $\mu$ H	220 $\mu$ H	220 $\mu$ H	220 $\mu$ H	220 $\mu$ H	150 $\mu$ H	150 $\mu$ H	150 $\mu$ H	150 $\mu$ H
3V	D52FU	130 $\mu$ H	130 $\mu$ H	130 $\mu$ H	130 $\mu$ H	130 $\mu$ H	130 $\mu$ H	130 $\mu$ H	130 $\mu$ H	130 $\mu$ H	130 $\mu$ H
	D62C	270 $\mu$ H	270 $\mu$ H	270 $\mu$ H	270 $\mu$ H	270 $\mu$ H	220 $\mu$ H	220 $\mu$ H	200 $\mu$ H	200 $\mu$ H	180 $\mu$ H
	D73LFE	390 $\mu$ H	330 $\mu$ H	330 $\mu$ H	220 $\mu$ H	220 $\mu$ H	220 $\mu$ H	220 $\mu$ H	220 $\mu$ H	150 $\mu$ H	150 $\mu$ H
3.3V	D52FU	130 $\mu$ H	130 $\mu$ H	130 $\mu$ H	130 $\mu$ H	130 $\mu$ H	130 $\mu$ H	130 $\mu$ H	130 $\mu$ H	130 $\mu$ H	130 $\mu$ H
	D62C	270 $\mu$ H	270 $\mu$ H	270 $\mu$ H	270 $\mu$ H	270 $\mu$ H	270 $\mu$ H	270 $\mu$ H	270 $\mu$ H	220 $\mu$ H	200 $\mu$ H
	D73LFE	470 $\mu$ H	390 $\mu$ H	330 $\mu$ H	330 $\mu$ H	220 $\mu$ H	220 $\mu$ H	220 $\mu$ H	220 $\mu$ H	220 $\mu$ H	150 $\mu$ H
3.6V	D52FU	130 $\mu$ H	130 $\mu$ H	130 $\mu$ H	130 $\mu$ H	130 $\mu$ H	130 $\mu$ H	130 $\mu$ H	130 $\mu$ H	130 $\mu$ H	130 $\mu$ H
	D62C	270 $\mu$ H	270 $\mu$ H	270 $\mu$ H	270 $\mu$ H	270 $\mu$ H	270 $\mu$ H	270 $\mu$ H	270 $\mu$ H	220 $\mu$ H	220 $\mu$ H
	D73LFE	560 $\mu$ H	470 $\mu$ H	390 $\mu$ H	330 $\mu$ H	330 $\mu$ H	220 $\mu$ H	220 $\mu$ H	220 $\mu$ H	220 $\mu$ H	220 $\mu$ H
3.9V	D52FU	130 $\mu$ H	130 $\mu$ H	130 $\mu$ H	130 $\mu$ H	130 $\mu$ H	130 $\mu$ H	130 $\mu$ H	130 $\mu$ H	130 $\mu$ H	130 $\mu$ H
	D62C	270 $\mu$ H	270 $\mu$ H	270 $\mu$ H	270 $\mu$ H	270 $\mu$ H	270 $\mu$ H	270 $\mu$ H	270 $\mu$ H	270 $\mu$ H	220 $\mu$ H
	D73LFE	560 $\mu$ H	470 $\mu$ H	390 $\mu$ H	390 $\mu$ H	330 $\mu$ H	330 $\mu$ H	220 $\mu$ H	220 $\mu$ H	220 $\mu$ H	220 $\mu$ H
4.2V	D52FU	130 $\mu$ H	130 $\mu$ H	130 $\mu$ H	130 $\mu$ H	130 $\mu$ H	130 $\mu$ H	130 $\mu$ H	130 $\mu$ H	130 $\mu$ H	130 $\mu$ H
	D62C	270 $\mu$ H	270 $\mu$ H	270 $\mu$ H	270 $\mu$ H	270 $\mu$ H	270 $\mu$ H	270 $\mu$ H	270 $\mu$ H	270 $\mu$ H	270 $\mu$ H
	D73LFE	560 $\mu$ H	560 $\mu$ H	470 $\mu$ H	390 $\mu$ H	390 $\mu$ H	330 $\mu$ H	330 $\mu$ H	220 $\mu$ H	220 $\mu$ H	220 $\mu$ H
4.5V	D52FU	130 $\mu$ H	130 $\mu$ H	130 $\mu$ H	130 $\mu$ H	130 $\mu$ H	130 $\mu$ H	130 $\mu$ H	130 $\mu$ H	130 $\mu$ H	130 $\mu$ H
	D62C	270 $\mu$ H	270 $\mu$ H	270 $\mu$ H	270 $\mu$ H	270 $\mu$ H	270 $\mu$ H	270 $\mu$ H	270 $\mu$ H	270 $\mu$ H	270 $\mu$ H
	D73LFE	680 $\mu$ H	560 $\mu$ H	470 $\mu$ H	470 $\mu$ H	390 $\mu$ H	390 $\mu$ H	330 $\mu$ H	330 $\mu$ H	220 $\mu$ H	220 $\mu$ H

Note: D52FU type 130  $\mu$ H and D62C type 270  $\mu$ H are the maximum value, because larger values of these types start losing inductance at 250mA.

## DESIGN CONSIDERATIONS

Given the capacitance of the EL Lamp, and the max inductance value from Table 4, Table 5 can be utilized to determine the expected peak output voltage.

TABLE 5: PEAK OUTPUT VOLTAGE VS. INDUCTOR VALUE AND LAMP CAPACITANCE

INDUCTOR VALUE	40 nF LAMP	45 nF LAMP	50 nF LAMP	55 nF LAMP	60 nF LAMP	70 nF LAMP	80 nF LAMP
100	50	47	45	43	41	38	35
120	55	52	49	47	45	41	39
130	57	54	51	49	47	43	40
150	61	58	55	52	50	46	43
180	67	63	60	57	55	51	47
200	71	67	63	60	58	53	50
220	74	70	66	63	61	56	52
270	82	77	73	70	67	62	58
330	91	86	81	77	74	69	64
390	99	93	88	84	81	75	70
470	108	102	97	92	89	82	77
560	118	112	106	101	97	89	84
680			117	111	106	99	92
820					117	108	101

PACKAGE OUTLINE

MSOP-10

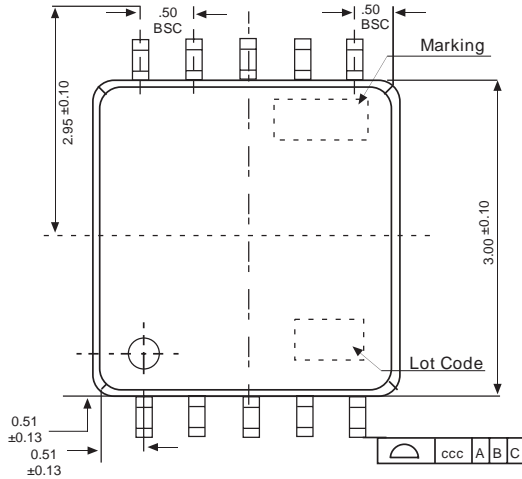

Marking Information

Product Code

- TK65940
- TK65941
- TK65942
- TK65943
- TK65944
- TK65945
- TK65946
- TK65947
- TK65948
- TK65949

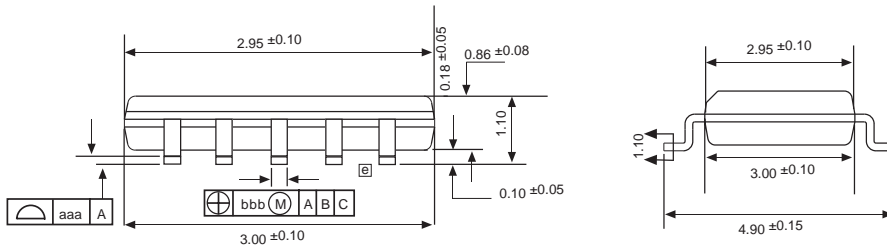

Dimensions are shown in millimeters  
Tolerance: x.x ± 0.2 mm (unless otherwise specified)



Toko America, Inc. Headquarters  
1250 Feehanville Drive, Mount Prospect, Illinois 60056  
Tel: (847) 297-0070 Fax: (847) 699-7864

TOKO AMERICA REGIONAL OFFICES

Midwest Regional Office  
Toko America, Inc.  
1250 Feehanville Drive  
Mount Prospect, IL 60056  
Tel: (847) 297-0070  
Fax: (847) 699-7864

Semiconductor Technical Support  
Toko Design Center  
4755 Forge Road  
Colorado Springs, CO 80907  
Tel: (719) 528-2200  
Fax: (719) 528-2375

Visit our Internet site at <http://www.tokoam.com>

The information furnished by TOKO, Inc. is believed to be accurate and reliable. However, TOKO reserves the right to make changes or improvements in the design, specification or manufacture of its products without further notice. TOKO does not assume any liability arising from the application or use of any product or circuit described herein, nor for any infringements of patents or other rights of third parties which may result from the use of its products. No license is granted by implication or otherwise under any patent or patent rights of TOKO, Inc. TOKO's products are not authorized for use as critical components in life support devices or systems without the express written approval of the president of Toko, Incorporated.