

SMA7036M 2-Phase Excitation

Absolute Maximum Ratings

Parameter	Symbol	Ratings	Unit
Motor Supply Voltage	V_{CC}	46	V
Control Supply Voltage	V_S	46	V
FET Drain-Source Voltage	V_{DSS}	100	V
TTL Input Voltage	V_{IN}	-0.3 to +7	V
SYNC Terminal Voltage	V_{SYNC}	-0.3 to +7	V
Reference Voltage	V_{REF}	-0.3 to +7	V
Sense Voltage	V_{RS}	-5 to +7	V
Output Current	I_O	1.5	A
Power Dissipation	P_{D1}	4.0 ($T_A=25^\circ\text{C}$)	W
	P_{D2}	28 ($T_C=25^\circ\text{C}$)	W
Channel Temperature	T_{ch}	150	$^\circ\text{C}$
Storage Temperature	T_{stg}	-40 to +150	$^\circ\text{C}$
Operating Ambient Temperature	T_a	-20 to +85	$^\circ\text{C}$

Electrical Characteristics

Parameter	Symbol	Ratings			Unit	
		min.	typ.	max.		
Control Supply Current	I_S		10	15	mA	
	Condition		$V_S=44\text{V}$			
Control Supply Voltage	V_S	10	24	44	V	
	Condition	100				
FET Drain-Source Voltage	V_{DSS}				V	
	Condition		$V_S=44\text{V}, I_{DSS}=250\mu\text{A}$			
FET ON Voltage	V_{DS}			0.6	V	
	Condition		$I_D=1\text{A}, V_S=10\text{V}$			
FET Diode Forward Voltage	V_{SD}			1.1	V	
	Condition		$I_{SD}=1\text{A}$			
FET Drain Leakage Current	I_{DSS}			250	μA	
	Condition		$V_{DSS}=100\text{V}, V_S=44\text{V}$			
IN Terminal	Active H	V_{IH}	2		V	
		Condition		$I_D=1\text{A}$		
		V_{IL}		0.8		
	Active L	Condition		$V_{DSS}=100\text{V}$		
		V_{IH}	2			
		Condition		$V_{DSS}=100\text{V}$		
Input Current	I_I			± 1	μA	
	Condition		$V_S=44\text{V}, V_I=0 \text{ or } 5\text{V}$			
SYNC Terminal	Input Voltage	$V_{SYNC H}$	4.0		V	
		Condition		Synchronous chopping mode		
		$V_{SYNC L}$				0.8
	Input Current	Condition		Asynchronous chopping mode		
		$I_{SYNC H}$			0.1	
		Condition		$V_S=44\text{V}, V_{YS}=5\text{V}$		
REF Terminal	Input Voltage	$I_{SYNC L}$		-0.1	mA	
		Condition		$V_S=44\text{V}, V_{YS}=0\text{V}$		
		V_{REF}	0			2.0
	Input Current	Condition		Reference voltage input		
		V_{REF}	4.0		5.5	
		Condition		Output FET OFF		
Internal Resistance	I_{REF}			± 1	μA	
	Condition		No synchronous trigger			
Internal Resistance	R_{REF}		40		Ω	
	Condition		Resistance between GND and REF terminal at synchronous trigger			
Switching Time	T_{ON}		1.5		μs	
		Condition		$V_S=24\text{V}, I_D=1\text{A}$		
	T_r		0.5			
		Condition		$V_S=24\text{V}, I_D=1\text{A}$		
	T_{stg}		0.9			
		Condition		$V_S=24\text{V}, I_D=1\text{A}$		
	T_f		0.1			
		Condition		$V_S=24\text{V}, I_D=1\text{A}$		
Chopping OFF Time	T_{OFF}		12		μs	
	Condition		$V_S=24\text{V}$			

Internal Block Diagram

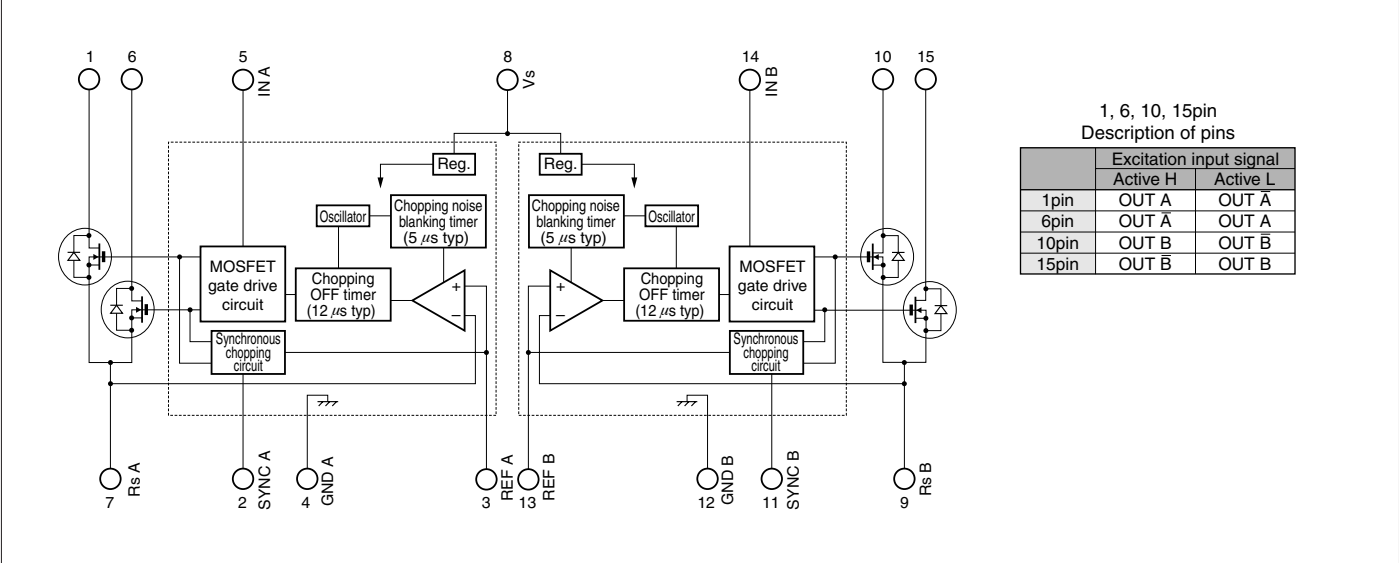

Typical Connection Diagram (Recommended component values)

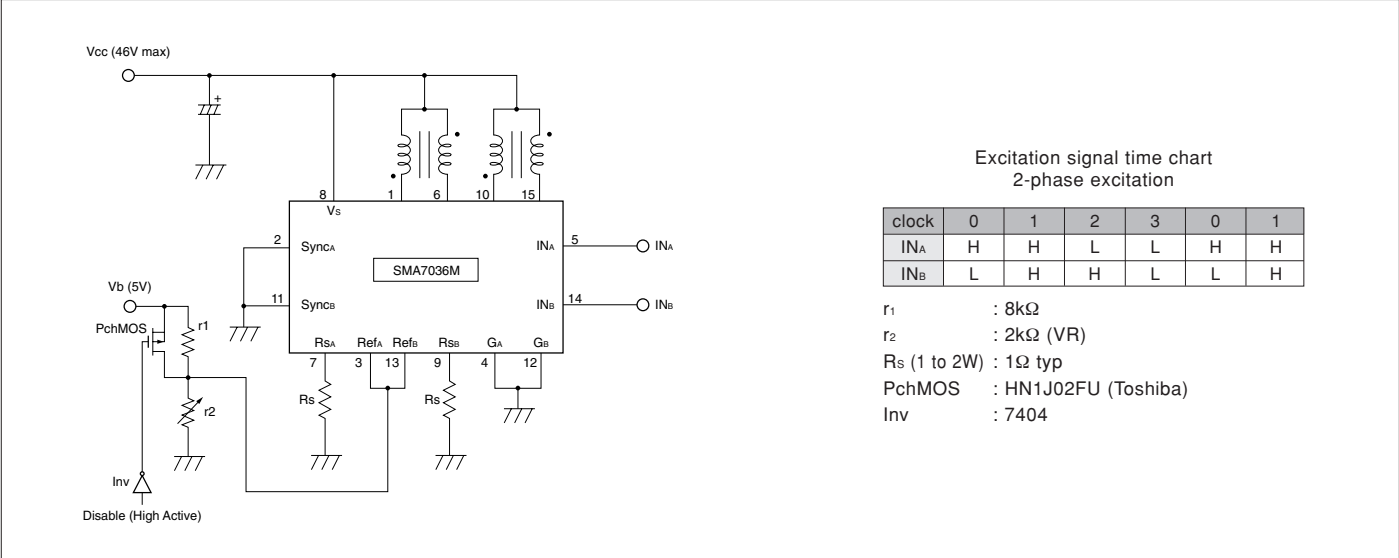

External Dimensions (ZIP15 [SMA15Pin])

(Unit : mm)

