

MM74HCT573 • MM74HCT574

Octal D-Type Latch • 3-STATE Octal D-Type Flip-Flop

General Description

The MM74HCT573 octal D-type latches and MM74HCT574 octal D-type flip-flop advanced silicon-gate CMOS technology, which provides the inherent benefits of low power consumption and wide power supply range, but are LS-TTL input and output characteristic and pin-out compatible. The 3-STATE outputs are capable of driving 15 LS-TTL loads. All inputs are protected from damage due to static discharge by internal diodes to V_{CC} and ground.

When the MM74HCT573 Latch Enable input is HIGH, the Q outputs will follow the D inputs. When the Latch Enable goes LOW, data at the D inputs will be retained at the outputs until Latch Enable returns HIGH again. When a high logic level is applied to the Output Control input, all outputs go to a high impedance state, regardless of what signals are present at the other inputs and the state of the storage elements.

The MM74HCT574 are positive edge triggered flip-flops. Data at the D inputs, meeting the setup and hold time requirements, are transferred to the Q outputs on positive

going transitions of the Clock (CK) input. When a high logic level is applied to the Output Control (OC) input, all outputs go to a high impedance state, regardless of what signals are present at the other inputs and the state of the storage elements.

The MM74HCT devices are intended to interface between TTL and NMOS components and standard CMOS devices. These parts are also plug in replacements for LS-TTL devices and can be used to reduce power consumption in existing designs.

Features

- TTL input characteristic compatible
- Typical propagation delay: 18 ns
- Low input current: 1 μ A maximum
- Low quiescent current: 80 μ A maximum
- Compatible with bus-oriented systems
- Output drive capability: 15 LS-TTL loads

Ordering Codes:

Order Number	Package Number	Package Description
MM74HCT573WM	M20B	20-Lead Small Outline Integrated Circuit (SOIC), JEDEC MS-013, 0.300 Wide
MM74HCT573SJ	M20D	20-Lead Small Outline Package (SOP), EIAJ TYPE II, 5.3mm Wide
MM74HCT573MTC	MTC20	20-Lead Thin Shrink Small Outline Package (TSSOP), JEDEC MO-153, 4.4mm Wide
MM74HCT573N	N20A	20-Lead Plastic Dual-In-Line Package (PDIP), JEDEC MS-001, 0.300 Wide
MM74HCT574WM	M20B	20-Lead Small Outline Integrated Circuit (SOIC), JEDEC MS-013, 0.300 Wide
MM74HCT574SJ	M20D	20-Lead Small Outline Package (SOP), EIAJ TYPE II, 5.3mm Wide
MM74HCT574MTC	MTC20	20-Lead Thin Shrink Small Outline Package (TSSOP), JEDEC MO-153, 4.4mm Wide
MM74HCT574N	N20A	20-Lead Plastic Dual-In-Line Package (PDIP), JEDEC MS-001, 0.300 Wide

Devices also available in Tape and Reel. Specify by appending suffix letter "X" to the ordering code.

Connection Diagrams

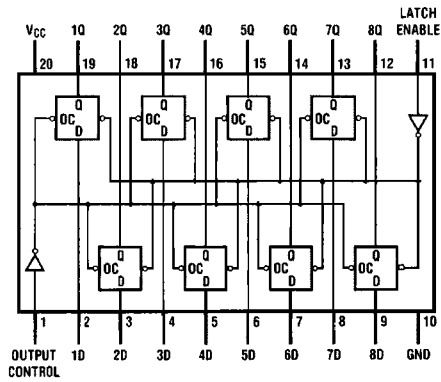

Top View
MM74HCT573

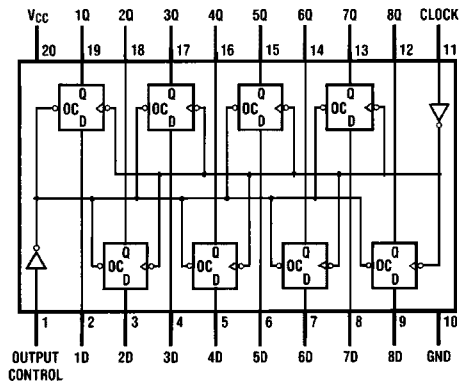

Top View
MM74HCT574

Truth Tables

MM74HCT573

Output Control	LE	Data	Output
L	H	H	H
L	H	L	L
L	L	X	Q ₀
H	X	X	Z

H = HIGH Level
 L = LOW Level
 Q₀ = Level of output before steady-state input conditions were established.
 Z = High Impedance State

MM74HCT574

Output Control	LE	Data	Output
L	↑	H	H
L	↑	L	L
L	L	X	Q ₀
H	X	X	Z

H = HIGH Level
 L = LOW Level
 Q₀ = Level of output before steady-state input conditions were established.
 X = Don't Care
 Z = High Impedance State
 ↑ = Transition from LOW-to-HIGH

Absolute Maximum Ratings (Note 1)

(Note 2)

Supply Voltage (V_{CC})	-0.5 to +7.0V
DC Input Voltage (V_{IN})	-1.5 to $V_{CC} + 1.5V$
DC Output Voltage (V_{OUT})	-0.5 to $V_{CC} + 0.5V$
Clamp Diode Current (I_{IK}, I_{OK})	± 20 mA
DC Output Current, per pin (I_{OUT})	± 35 mA
DC V_{CC} or GND Current, per pin (I_{CC})	± 70 mA
Storage Temperature Range (T_{STG})	-65°C to +150°C
Power Dissipation (P_D)	
(Note 3)	600 mW
S. O. Package only	500 mW
Lead Temperature (T_L)	
(Soldering 10 seconds)	260°C

Recommended Operating Conditions

	Min	Max	Units
Supply Voltage (V_{CC})	4.5	5.5	V
DC Input or Output Voltage (V_{IN}, V_{OUT})	0	V_{CC}	V
Operating Temperature Range (T_A)	-40	+85	°C
Input Rise or Fall Times t_r, t_f		500	ns

Note 1: Absolute Maximum Ratings are those values beyond which damage to the device may occur.

Note 2: Unless otherwise specified all voltages are referenced to ground.

Note 3: Power Dissipation temperature derating — plastic "N" package: — 12 mW/°C from 65°C to 85°C.

DC Electrical Characteristics $V_{CC} = 5V \pm 10\%$ (unless otherwise specified)

Symbol	Parameter	Conditions	$T_A = 25^\circ\text{C}$		$T_A = -40$ to 85°C	$T_A = -55$ to 125°C	Units
			Typ	Guaranteed Limits			
V_{IH}	Minimum HIGH Level Input Voltage			2.0	2.0	2.0	V
V_{IL}	Maximum LOW Level Input Voltage			0.8	0.8	0.8	V
V_{OH}	Minimum HIGH Level Output Voltage	$V_{IN} = V_{IH}$ or V_{IL} $ I_{OUT} = 20 \mu\text{A}$ $ I_{OUT} = 6.0 \text{ mA}, V_{CC} = 4.5V$ $ I_{OUT} = 7.2 \text{ mA}, V_{CC} = 5.5V$	V_{CC} 4.2 5.7	$V_{CC} - 0.1$ 3.98 4.98	$V_{CC} - 0.1$ 3.84 4.84	$V_{CC} - 0.1$ 3.7 4.7	V
V_{OL}	Maximum LOW Level Voltage	$V_{IN} = V_{IH}$ or V_{IL} $ I_{OUT} = 20 \mu\text{A}$ $ I_{OUT} = 6.0 \text{ mA}, V_{CC} = 4.5V$ $ I_{OUT} = 7.2 \text{ mA}, V_{CC} = 5.5V$	0 0.2 0.2	0.1 0.26 0.26	0.1 0.33 0.33	0.1 0.4 0.4	V
I_{IN}	Maximum Input Current	$V_{IN} = V_{CC}$ or GND, V_{IH} or V_{IL}		± 0.1	± 1.0	± 1.0	μA
I_{OZ}	Maximum 3-STATE Output Leakage Current	$V_{OUT} = V_{CC}$ or GND Enable = V_{IH} or V_{IL}		± 0.5	± 5.0	± 10	μA
I_{CC}	Maximum Quiescent Supply Current	$V_{IN} = V_{CC}$ or GND $I_{OUT} = 0 \mu\text{A}$ $V_{IN} = 2.4V$ or $0.5V$ (Note 4)		8.0 1.5	80 1.8	160 2.0	μA mA

Note 4: Measured per pin. All others tied to V_{CC} or ground.

AC Electrical Characteristics MM74HCT573 $V_{CC} = 5.0V$, $t_r = t_f = 6$ ns, $T_A = 25^\circ C$ (unless otherwise specified)

Symbol	Parameter	Conditions	Typ	Guaranteed Limit	Units
t_{PHL} t_{PLH}	Maximum Propagation Delay Data to Output	$C_L = 45$ pF	17	27	ns
t_{PHL} t_{PLH}	Maximum Propagation Delay Latch Enable to Output	$C_L = 45$ pF	16	27	ns
t_{PZH} t_{PZL}	Maximum Enable Propagation Delay Control to Output	$C_L = 45$ pF $R_L = 1$ k Ω	21	30	ns
t_{PHZ} t_{PLZ}	Maximum Disable Propagation Delay Control to Output	$C_L = 5$ pF $R_L = 1$ k Ω	14	23	ns
t_W	Minimum Clock Pulse Width			15	ns
t_S	Minimum Setup Time Data to Clock			5	ns
t_H	Minimum Hold Time Clock to Data			12	ns

AC Electrical Characteristics MM74HCT573 $V_{CC} = 5.0V \pm 10\%$, $t_r = t_f = 6$ ns (unless otherwise specified)

Symbol	Parameter	Conditions	$T_A = 25^\circ$		$T_A = -40$ to $85^\circ C$	$T_A = -55$ to $125^\circ C$	Units
			Typ	Guaranteed Limits			
t_{PHL} t_{PLH}	Maximum Propagation Delay Data to Output	$C_L = 50$ pF	18	30	38	45	ns
t_{PHL} t_{PLH}	Maximum Propagation Delay Latch Enable to Output	$C_L = 50$ pF	17	30	44	53	ns
t_{PZH} t_{PZL}	Maximum Enable Propagation Delay Control to Output	$C_L = 50$ pF $R_L = 1$ k Ω	22	30	38	45	ns
t_{PHZ} t_{PLZ}	Maximum Disable Propagation Delay Control to Output	$C_L = 50$ pF $R_L = 1$ k Ω	15	30	38	45	ns
t_{THL} t_{TLH}	Maximum Output Rise and Fall Time	$C_L = 50$ pF	6	12	15	18	ns
t_W	Minimum Clock Pulse Width			15	20	24	ns
t_S	Minimum Setup Time Data to Clock		-3	5	6	8	ns
t_H	Minimum Hold Time Clock to Data		4	12	15	18	ns
C_{IN}	Maximum Input Capacitance			10	10	10	pF
C_{OUT}	Maximum Output Capacitance			20	20	20	pF
C_{PD}	Power Dissipation Capacitance (Note 5)	OC = V_{CC} OC = GND		5 52			pF

Note 5: C_{PD} determines the no load dynamic power consumption, $P_D = C_{PD} V_{CC}^2 f_{+LCC} V_{CC}$, and the no load dynamic current consumption, $I_S = C_{PD} V_{CC} f_{+LCC}$.

AC Electrical Characteristics MM74HCT574 $V_{CC} = 5.0V$, $t_r = t_f = 6$ ns, $T_A = 25^\circ C$

Symbol	Parameter	Conditions	Typ	Guaranteed Limit	Units
f_{MAX}	Maximum Clock Frequency		60	33	MHz
t_{PHL} t_{PLH}	Maximum Propagation Delay to Output	$C_L = 45$ pF	17	27	ns
t_{PZH} t_{PZL}	Maximum Enable Propagation Delay Control to Output	$C_L = 45$ pF $R_L = 1$ k Ω	19	28	ns
t_{PHZ} t_{PLZ}	Maximum Disable Propagation Delay Control to Output	$C_L = 45$ pF $R_L = 1$ k Ω	14	25	ns
t_W	Minimum Clock Pulse Width			15	ns
t_S	Minimum Setup Time Data to Clock			12	ns
t_H	Minimum Hold Time Clock to Data			5	ns

AC Electrical Characteristics MM74HCT574 $V_{CC} = 5.0V \pm 10\%$, $t_r = t_f = 6$ ns (unless otherwise specified)

Symbol	Parameter	Conditions	$T_A = 25^\circ C$			Units	
			Typ	Guaranteed Limits			
				$T_A = -40$ to $85^\circ C$	$T_A = -55$ to $125^\circ C$		
f_{MAX}	Maximum Clock Frequency			33	28	23	MHz
t_{PHL} t_{PLH}	Maximum Propagation Delay Clock to Output	$C_L = 50$ pF	18	30	38	45	ns
t_{PZH} t_{PZL}	Maximum Enable Propagation Delay Control to Output	$C_L = 50$ pF $R_L = 1$ k Ω	22	30	38	45	ns
t_{PHZ} t_{PLZ}	Maximum Disable Propagation Delay Control to Output	$C_L = 50$ pF $R_L = 1$ k Ω	15	30	38	45	ns
t_{THL} t_{TLH}	Maximum Output Rise and Fall Time	$C_L = 50$ pF	6	12	15	18	ns
t_W	Minimum Clock Pulse Width			15	20	24	ns
t_S	Minimum Setup Time Data to Clock		6	12	15	18	ns
t_H	Minimum Hold Time Clock to Data		-1	5	6	8	ns
C_{IN}	Maximum Input Capacitance			10	10	10	pF
C_{OUT}	Maximum Output Capacitance			20	20	20	pF
C_{PD}	Power Dissipation Capacitance (Note 6)	$OC = V_{CC}$ $OC = GND$	5 58				pF

Note 6: C_{PD} determines the no load power consumption, $P_D = C_{PD} V_{CC}^2 f + I_{CC} V_{CC}$, and the no load dynamic current consumption, $I_S = C_{PD} V_{CC} f + I_{CC}$.

Physical Dimensions inches (millimeters) unless otherwise noted

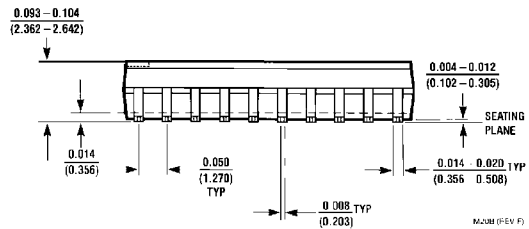
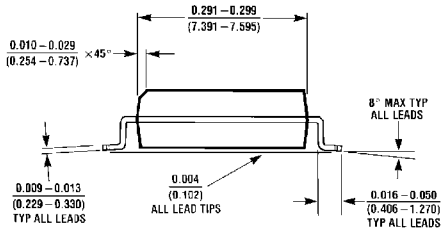
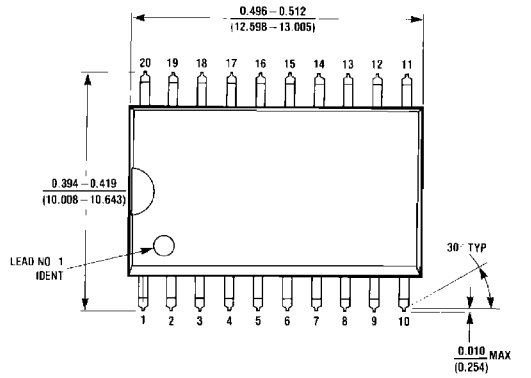

**20-Lead Small Outline Integrated Circuit (SOIC), JEDEC MS-013, 0.300 Wide
Package Number M20B**

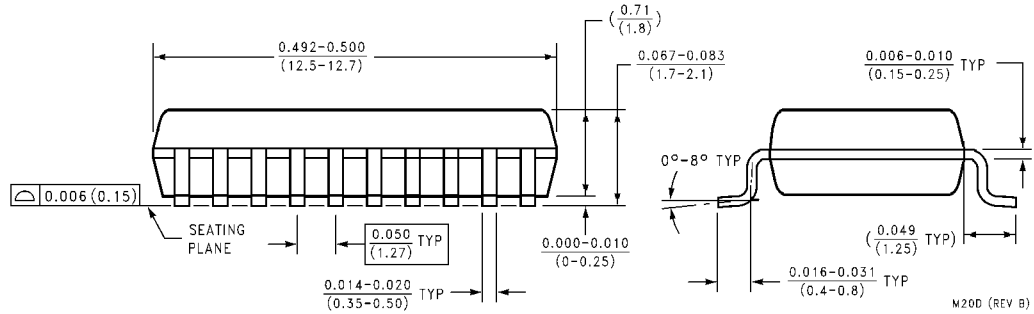
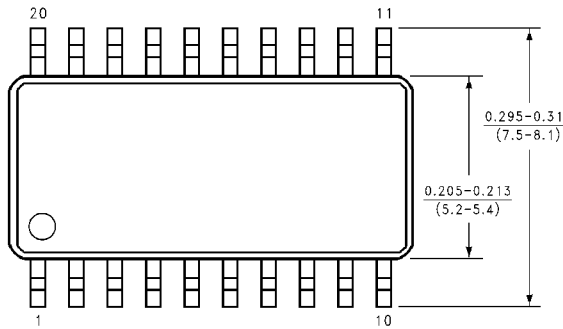

**20-Lead Small Outline Package (SOP), EIAJ TYPE II, 5.3mm Wide
Package Number M20D**

Physical Dimensions inches (millimeters) unless otherwise noted (Continued)

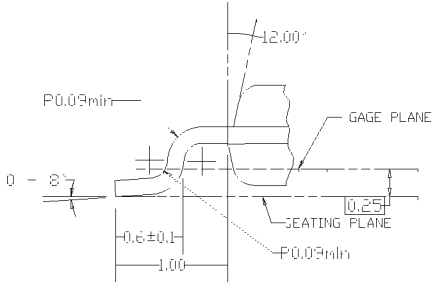
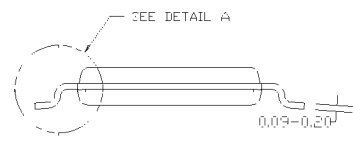
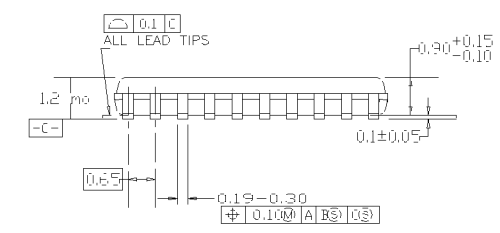
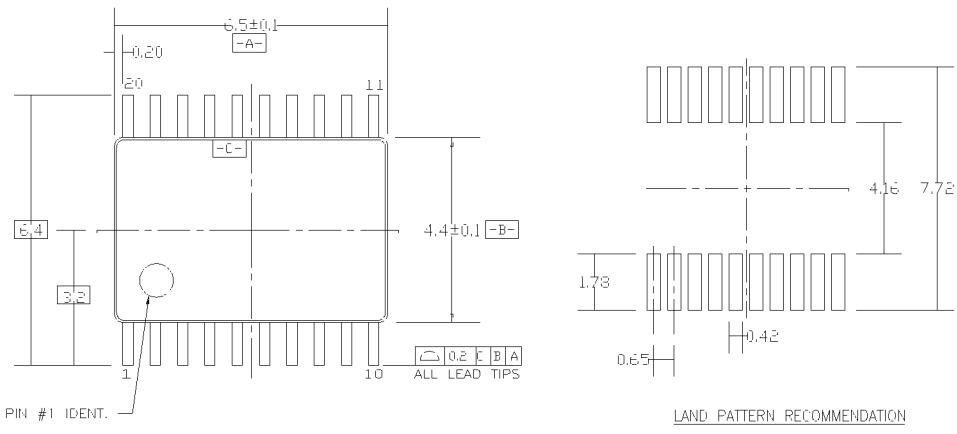

DIMENSIONS ARE IN MILLIMETERS

- NOTES
- A. CONFORMS TO JEDEC REGISTRATION MO-153, VARIATION AC, REF NOTE 6, DATE 7/93.
 - B. DIMENSIONS ARE IN MILLIMETERS.
 - C. DIMENSIONS ARE EXCLUSIVE OF BURRS, MOLDS FLASH, AND TIE BAR EXTRUSIONS.
 - D. DIMENSIONS AND TOLERANCES PER ANSI Y14.5M, 1982.

MTC20PEVD1

20-Lead Thin Shrink Small Outline Package (TSSOP), JEDEC MO-153, 4.4mm Wide
Package Number MTC20

Physical Dimensions inches (millimeters) unless otherwise noted (Continued)

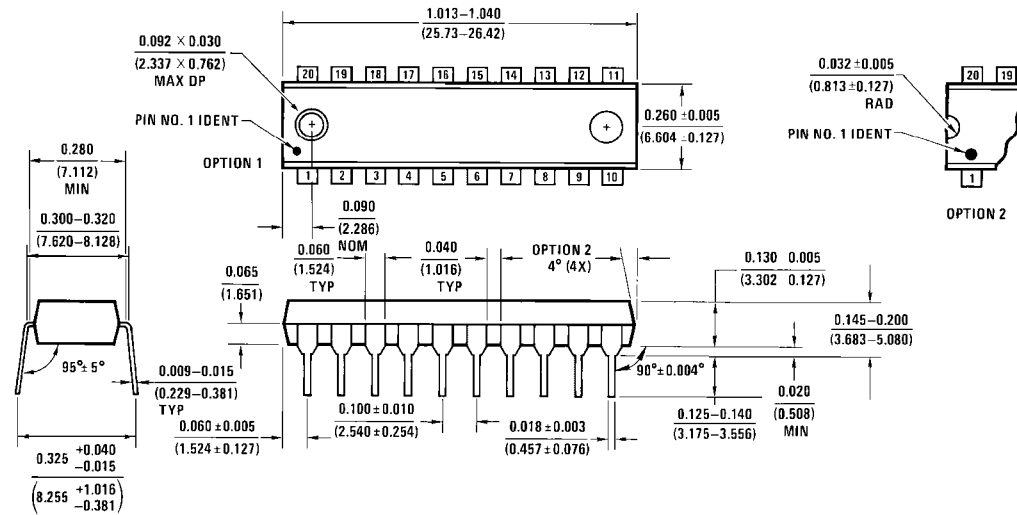

N20A (REV G)

20-Lead Plastic Dual-In-Line Package (PDIP), JEDEC MS-001, 0.300 Wide Package Number N20A

LIFE SUPPORT POLICY

FAIRCHILD'S PRODUCTS ARE NOT AUTHORIZED FOR USE AS CRITICAL COMPONENTS IN LIFE SUPPORT DEVICES OR SYSTEMS WITHOUT THE EXPRESS WRITTEN APPROVAL OF THE PRESIDENT OF FAIRCHILD SEMICONDUCTOR CORPORATION. As used herein:

1. Life support devices or systems are devices or systems which, (a) are intended for surgical implant into the body, or (b) support or sustain life, and (c) whose failure to perform when properly used in accordance with instructions for use provided in the labeling, can be reasonably expected to result in a significant injury to the user.
2. A critical component in any component of a life support device or system whose failure to perform can be reasonably expected to cause the failure of the life support device or system, or to affect its safety or effectiveness.

www.fairchildsemi.com