



KUSBX Series
Right Angle Universal Serial Bus



Features

- Through Hole PCB Mount
- Compatible with Many Computer Peripherals
- A and B Types Available
- Supports Hot Plugging
- Contact Area with Gold Plating
- CSA/NRTL Certified File No. LR78160

Performance Specifications

Materials and Finish

Insulator: PBT Thermoplastic, UL94V-0 Rated, Black or White Color

Contacts: Phosphor Bronze

Plating: Gold on Contact Area
Tin on Solderetails, All over Nickel

Shell: Brass, Nickel Plated

Mechanical Characteristics

Insertion Force: 3.57kg Max.

Extraction Force: 1.02kg Min.

Durability: 1500 Mating Cycles Min.

Electrical Characteristics

Rated Voltage: 30V AC (RMS)

Rated Current: 1A

Contact Resistance: 30 milliohms Max.

Insulation Resistance: 1000 Megohms Min.

Dielectric Withstanding Voltage: 750V AC

Operating Temperature: See Drawing

UNIVERSAL SERIAL BUS
KUSBX Series

Ordering Information

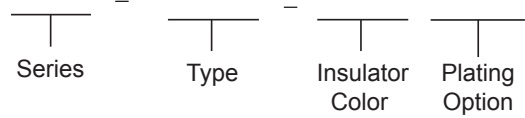

Series

KUSBX - Right Angle USB

Type

- AS1N - A Type
- BS1N - B Type
- AS2N - Stacked A Type
- ASBS2N - Stacked A Type with Back Shield

Insulator Color Option

- B - Black
- W - White

Plating Option

- Blank - Gold Flash
- 30 - 30µ" Gold

Contact Kycon for more options

KUSBX-AS1N

Dimensions in mm

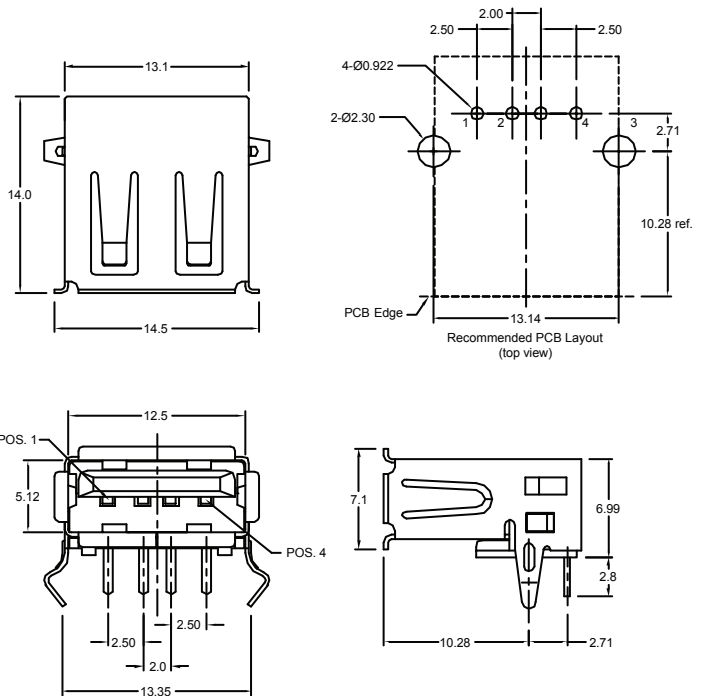

*See next page for more dimensions

