

CX77105

Power Amplifier Module for CDMA/AMPS (824–849 MHz)

The CX77105, a dual-mode, Code Division Multiple Access (CDMA) / Advanced Mobile Phone Service (AMPS) Power Amplifier Module (PAM), is a fully matched, 10-pin surface mount module developed for cellular handsets and wireless local loop applications. This small and efficient power amplifier module packs a full 824–849 MHz bandwidth coverage into a single compact package. The device meets the stringent IS95 CDMA linearity requirements to and exceeding 28 dBm output power, and can be driven to levels beyond 31 dBm for high efficiency in FM mode operation. A low current digital pin (VCONT) provides improved efficiency for the low RF power range of operation.

The single Gallium Arsenide (GaAs) Microwave Monolithic Integrated Circuit (MMIC) contains all active circuitry in the module. The MMIC contains on-board bias circuitry, as well as input and interstage matching circuits. The output match is realized off-chip and within the module package to optimize efficiency and power performance into a 50 Ω load. This device is manufactured with Skyworks' GaAs Heterojunction Bipolar Transistor (HBT) process that provides for all positive voltage DC supply operation while maintaining high efficiency and good linearity. Primary bias to the CX77105 is supplied directly from a three-cell nickel cadmium, a single-cell lithium ion, or other suitable battery with an output in the 3–4 volt range. Power down is accomplished by setting the voltage on the low current reference pin to zero volts. No external supply side switch is needed as typical "off" leakage is a few microamperes with full primary voltage supplied from the battery.

Distinguishing Features

- Low voltage positive bias supply (3.2 V to 4.2 V, typical)
- Good linearity
- High efficiency
- Dual mode operation
- Large dynamic range
- 10-pin package (4 x 4 x 1.5 mm)
- Power down control
- Low power-state control
- InGaP
- IS 95/CDMA2000

Applications

- Digital cellular (CDMA)
- Analog cellular (AMPS)
- Wireless local loop (WLL)

Functional Block Diagram

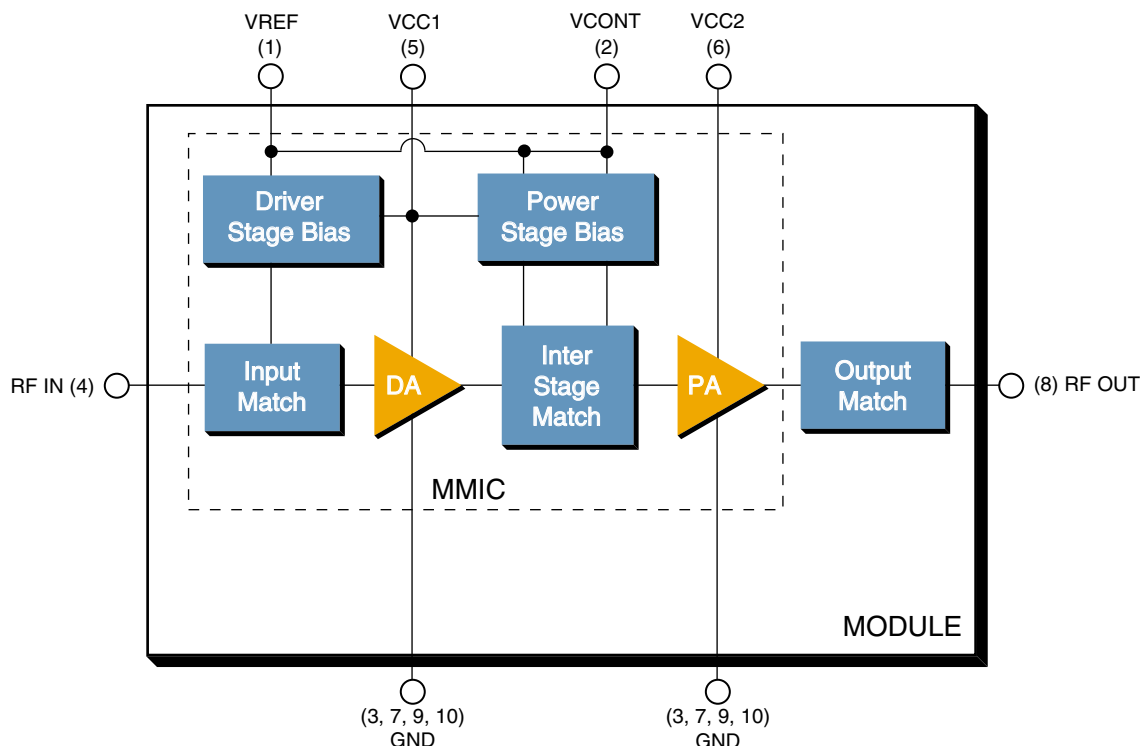

Electrical Specifications

The following tables list the electrical characteristics of the CX77105 Power Amplifier. [Table 2](#) lists the recommended operating conditions for achieving the electrical performance listed in [Table 4](#). [Table 3](#) lists the electrical performance of the CX77105 Power Amplifier over the recommended operating conditions.

Table 1. Absolute Maximum Ratings⁽¹⁾

Parameter	Symbol	Minimum	Nominal	Maximum	Unit
RF Input Power	P _{IN}	—	4.0	7.0	dBm
Supply Voltage	V _{CC}	—	3.4	6.0	Volts
Reference Voltage	V _{REF}	—	3.0	3.1	Volts
Case Operating Temperature	T _C	–30	25	+110	°C
Storage Temperature	T _{STG}	–55	—	+125	°C
NOTE(S): (1) No damage assuming only one parameter is set at limit at a time with all other parameters set at or below nominal value.					

Table 2. Recommended Operating Conditions

Parameter	Symbol	Minimum	Nominal	Maximum	Unit
Supply Voltage	V _{CC}	3.2	3.4	4.2	Volts
Reference Voltage	PA On	V _{REF}	2.95	3.0	Volts
	PA Off	V _{REF}	—	0.5	
Mode Input Impedance >2.5 kΩ	High Bias	V _{CONT}	0.0	—	Volts
	Low Bias	V _{CONT}	2.5	—	
Operating Frequency	F ₀	824.0	836.5	849.0	MHz
Operating Temperature	T ₀	–30	—	+85	°C

Table 3. Power Range Truth Table

Power Mode	V _{REF}	V _{CONT}	Range
High Power	3.0 V	0.0–0.5 V	16 dBm–28 dBm
Low Power	3.0 V	2.5–3.0 V	≤ 16 dBm
Shut Down	0.0 V	0.0 V	—

Power Amplifier Module for CDMA/AMPS (824–849 MHz)

Table 4. Electrical Specifications for CDMA / AMPS Nominal Operating Conditions⁽¹⁾

Characteristics	Symbol	Condition	Minimum	Typical	Maximum	Unit	
Gain conditions	Digital Mode	G_{LOW}	$V_{CONT} \geq 2.5 V$ $P_O = 16 \text{ dBm}$	25.0	27.0	28.0	dB
		G_{HIGH}	$V_{CONT} \leq 0.5 V$ $P_O = 28 \text{ dBm}$	28.5	29.0	31.0	
	Analog Mode	G_P	$V_{CONT} \leq 0.5 V$ $P_O = 31 \text{ dBm}$	27.5	29.0	31.0	
Power Added Efficiency	Digital Mode	PAE_{LOW}	$V_{CONT} \geq 2.5 V$ $P_O = 16 \text{ dBm}$	7.6	8.5	—	%
		PAE_{HIGH}	$V_{CONT} \leq 0.5 V$ $P_O = 28 \text{ dBm}$	37.0	40.0	—	
	Analog Mode	PAE_a	$V_{CONT} \leq 0.5 V$ $P_O = 31 \text{ dBm}$	48.0	55.0	—	
Total Supply Current	I_{CC_LOW} I_{CC_HIGH}	$P_O = 16 \text{ dBm}$	—	137	153	mA	
		$P_O = 28 \text{ dBm}$	—	490	500		
Quiescent Current	I_{Q_LOW} I_{Q_HIGH}	$V_{CONT} \geq 2.5 V$	40	55	75	mA	
		$V_{CONT} \leq 0.5 V$	60	78	105		
Reference Current	I_{REF}	—	—	2.5	5.0	mA	
Control Current	I_{CTRL}	$V_{CONT} = 2.5 V$	200	235	500	μA	
Total Supply current in Power-down Mode	I_{PD}	$V_{CC} = 3.4 V$ $V_{REF} = 0 V$	—	3.0	5.0	μA	
Adjacent Channel Power ⁽²⁾⁽³⁾	885 kHz offset	$ACP1_{LOW}$	$V_{CONT} \geq 2.5 V$ $P_O \leq 16 \text{ dBm}$	—	-49.0	-47.3	dBc
		$ACP1_{HIGH}$	$V_{CONT} \leq 0.5 V$ $P_O \leq 28 \text{ dBm}$	—	-50.0	-47.0	
	1.98 MHz offset	$ACP2_{LOW}$	$V_{CONT} \geq 2.5 V$ $P_O \leq 16 \text{ dBm}$ or $V_{CONT} \leq 0.5 V$ $P_O \leq 28 \text{ dBm}$	—	-65.0	-59.0	
		$ACP2_{HIGH}$	$V_{CONT} \leq 0.5 V$ $P_O \leq 28 \text{ dBm}$	—	-60.0	-57.4	
Harmonic Suppression	Second	F_{o2}	$P_O \leq 28 \text{ dBm}$	—	-38.0	-35.0	dBc
	Third	F_{o3}	$P_O \leq 28 \text{ dBm}$	—	-59.0	-45.0	

Table 4. Electrical Specifications for CDMA / AMPS Nominal Operating Conditions⁽¹⁾

Characteristics	Symbol	Condition	Minimum	Typical	Maximum	Unit
Noise Power in RX Band 869-894 MHz	RxBN	$P_0 \leq 28$ dBm	—	-137	—	dBm/Hz
Noise Figure	NF	—	—	4.6	5.0	dB
Input Voltage Standing Wave Ratio	VSWR	—	—	—	1.9:1	—
Stability (Spurious output)	S	5:1 VSWR all phases	—	—	-60.0	dBc
Ruggedness—No damage ⁽⁴⁾	Ru	$P_0 \leq 28$ dBm	10:1	—	—	VSWR

NOTE(S):
⁽¹⁾ $V_{CC} = +3.4$ V, $V_{REF} = +3.0$ V, Freq = 836.5 MHz, $T_C = 25$ °C, unless otherwise specified.
⁽²⁾ ACP is specified per IS95 as the ratio of the total in-band power (1.23 MHz BW) to adjacent power in a 30 kHz BW.
⁽³⁾ CDMA2000 is configured as DCCH = 9600, SCHO = 9600, PCH (Walsh 0) = -3.75 dB, and Peak-to-Average Ratio (CCDF = 1%) = 4.5 dB. For CDMA2000, 0.5 dB back-off in output power is required.
⁽⁴⁾ All phases, time = 10 seconds.

Table 5. Electrical Specifications for CDMA / AMPS Recommended Operating Conditions⁽¹⁾

Characteristics	Symbol	Condition	Minimum	Maximum	Unit	
Gain conditions	Digital Mode	G_{LOW}	$V_{CONT} \geq 2.5$ V $P_0 = 16$ dBm	24.0	28.5	dB
		G_{HIGH}	$V_{CONT} \leq 0.5$ V $P_0 = 28$ dBm	27.1	32.4	
	Analog Mode	G_P	$V_{CONT} \leq 0.5$ V $P_0 = 31$ dBm	24.0	33.0	
Adjacent Channel Power ⁽²⁾⁽³⁾	1.25 MHz offset	$ACP1_{LOW}$	$V_{CONT} \geq 2.5$ V $P_0 \leq 16$ dBm	—	-44	dBc
		$ACP1_{HIGH}$	$V_{CONT} \leq 0.5$ V $P_0 \leq 28$ dBm	—	-44	dBc
	1.98 MHz offset	$ACP2_{LOW}$	$V_{CONT} \geq 2.5$ V $P_0 \leq 16$ dBm	—	-56	dBc
		$ACP2_{HIGH}$	or $V_{CONT} \leq 0.5$ V $P_0 \leq 28$ dBm	—	-56	dBc
Harmonic Suppression	Second	F_02	$P_0 \leq 28$ dBm	—	-30	dBc
	Third	F_03	$P_0 \leq 28$ dBm	—	-40	dBc

Power Amplifier Module for CDMA/AMPS (824–849 MHz)

Table 5. Electrical Specifications for CDMA / AMPS Recommended Operating Conditions⁽¹⁾

Characteristics	Symbol	Condition	Minimum	Maximum	Unit
Noise Power in RX Band 869-894 MHz	RxBN	$P_0 \leq 28$ dBm	—	-134.0	dBm/Hz
Noise Figure	NF	—	—	7.0	dB
Input Voltage Standing Wave Ratio (VSWR)	VSWR	—	—	2.0:1	—
Stability (Spurious output)	S	5:1 VSWR All phases	—	-60.0	dBc
Ruggedness – No damage ⁽⁴⁾	Ru	$P_0 \leq 28$ dBm	10:1	—	VSWR

NOTE(S):

(1) Per Table 2, unless otherwise specified.

(2) ACP is specified per IS95 as the ratio of the total in-band power (1.23 MHz BW) to adjacent power in a 30 kHz BW.

(3) CDMA2000 is configured as DCCH = 9600, SCHO = 9600, PCH (Walsh 0) = -3.75 dB, and Peak-to-Average Ratio (CCDF = 1%) = 4.5 dB. For CDMA2000, 0.5 dB back-off in output power is required.

(4) All phases, time = 10 seconds.

Characterization Data

The following graphs illustrate the characteristics of a typical CX77105 power amplifier designed for operation in the cellular frequency band (824–849 MHz). This amplifier was selected by characterizing a group of devices and then selecting a part with average electrical performance for both nominal and the full range of recommended operating conditions, including worst case limits. Figures 1 through 7 illustrate the digital signal characteristics of the CX77105. Shown are power sweep characteristics for key performance parameters, over temperature and frequency, up to 28.5 dBm output power. The data was taken up to and including 16 dBm output power with the bias mode control pin setting of $V_{CONT} = 2.5$ volts. Beyond 16 dBm output power, the V_{CONT} was set to 0 volts.

Figure 1. Digital Mode Gain vs. Output Power

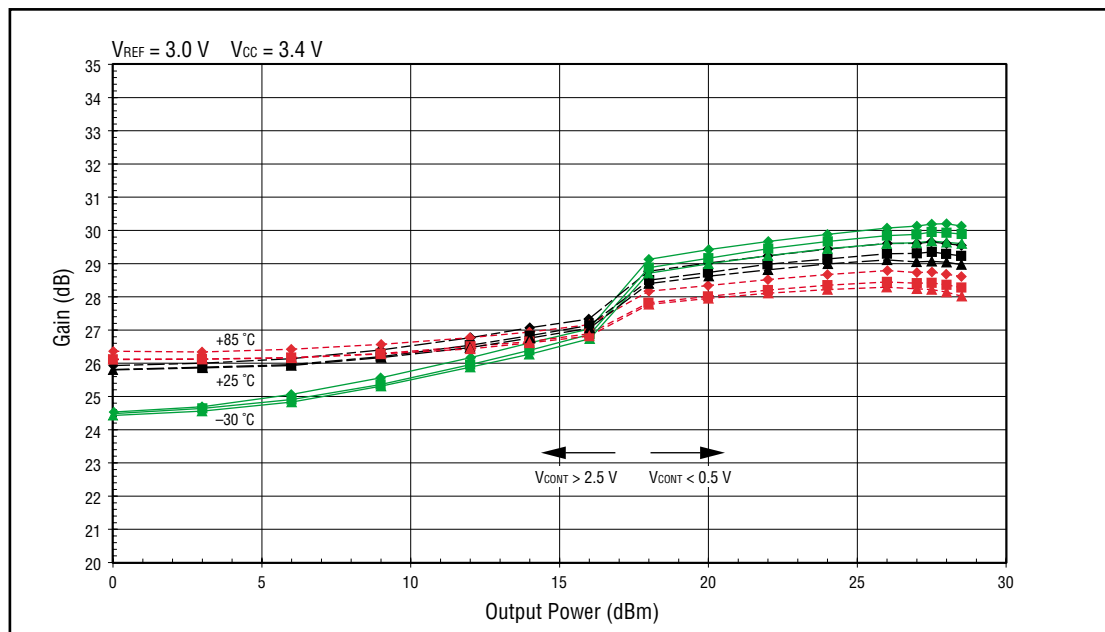

101787_009

Legend

—◆— 824 @ -30 °C	—◆— 824 @ +25 °C	—◆— 824 @ +85 °C
—■— 837 @ -30 °C	—■— 837 @ +25 °C	—■— 837 @ +85 °C
—▲— 849 @ -30 °C	—▲— 849 @ +25 °C	—▲— 849 @ +85 °C

Figure 2. Primary Bias Current vs. Output Power

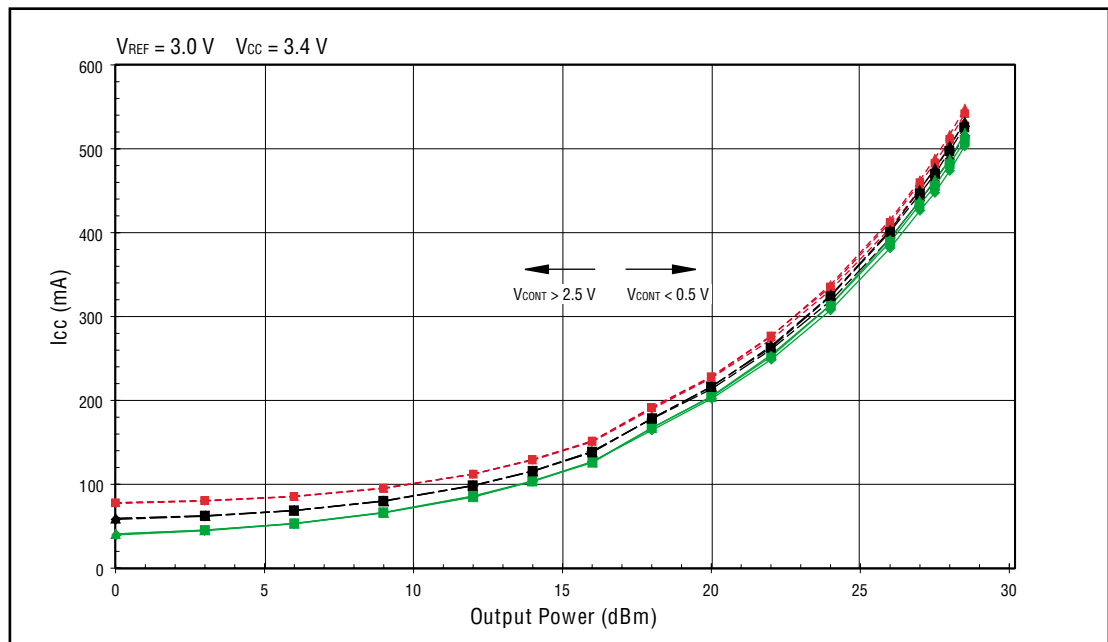

101787_010

Figure 3. Power Added Efficiency vs. Output Power

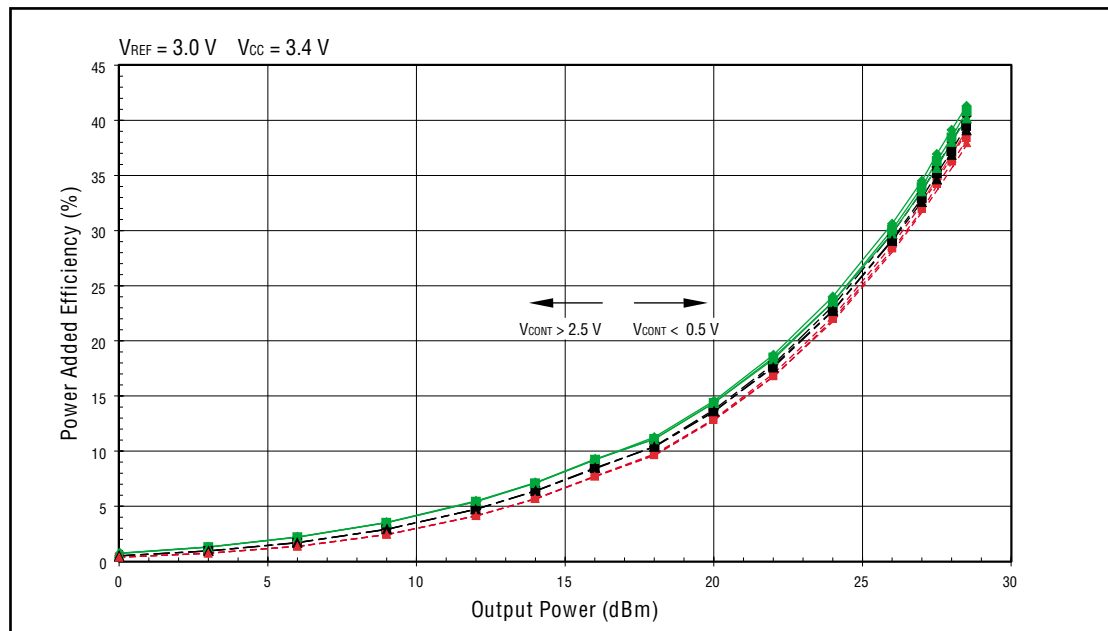

101787_011

Legend

—◆— 824 @ -30 °C	-◆- 824 @ +25 °C	-◆- 824 @ +85 °C
—■— 837 @ -30 °C	-■- 837 @ +25 °C	-■- 837 @ +85 °C
—▲— 849 @ -30 °C	-▲- 849 @ +25 °C	-▲- 849 @ +85 °C

Figure 4. Adjacent Channel Power for 885 kHz Offset Current vs. Output Power

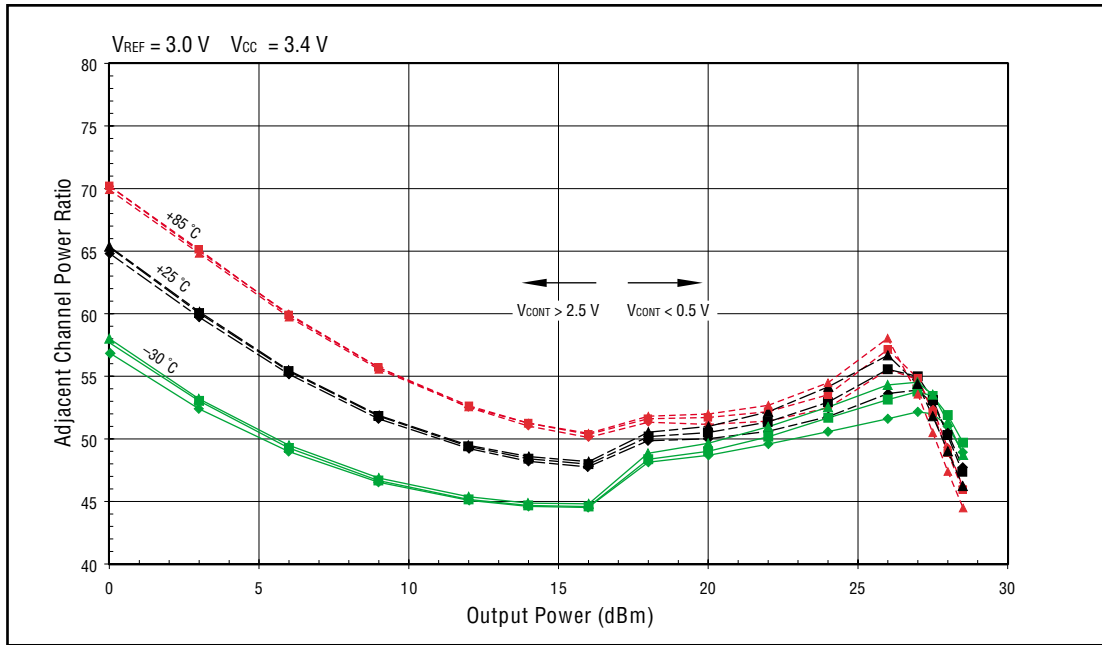

101787_012

Figure 5. Adjacent Channel Power for 1.98 MHz Offset vs. Output Power

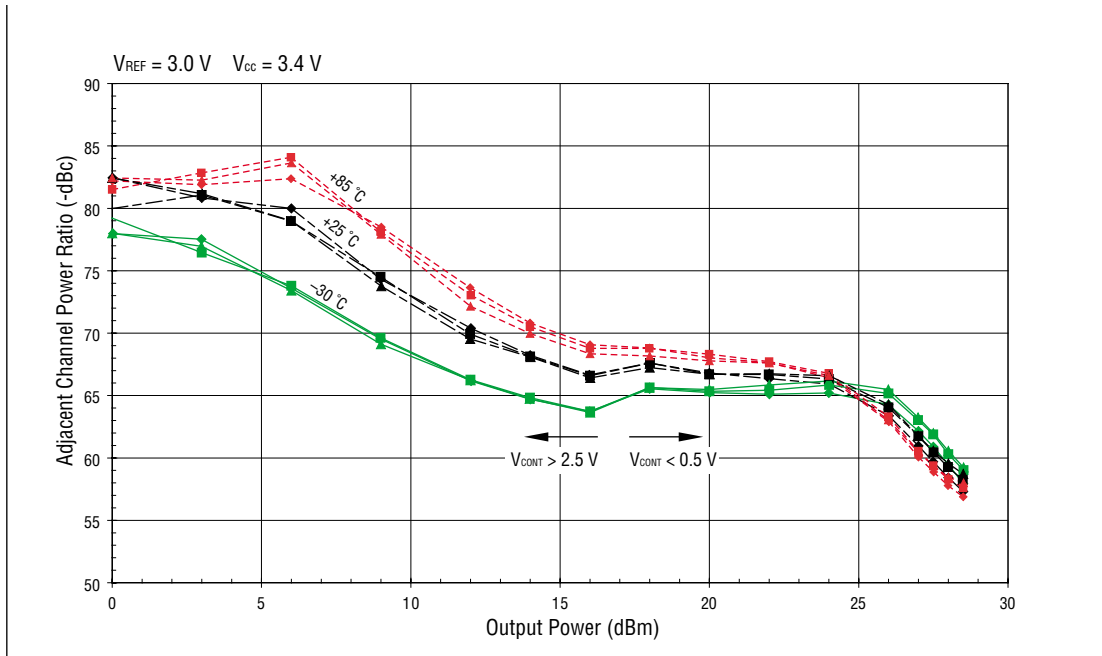

Legend

—◆— 824 @ -30 °C	—◆— 824 @ +25 °C	—◆— 824 @ +85 °C
—■— 837 @ -30 °C	—■— 837 @ +25 °C	—■— 837 @ +85 °C
—▲— 849 @ -30 °C	—▲— 849 @ +25 °C	—▲— 849 @ +85 °C

Figure 6. Second Harmonic Rejection vs. Output Power

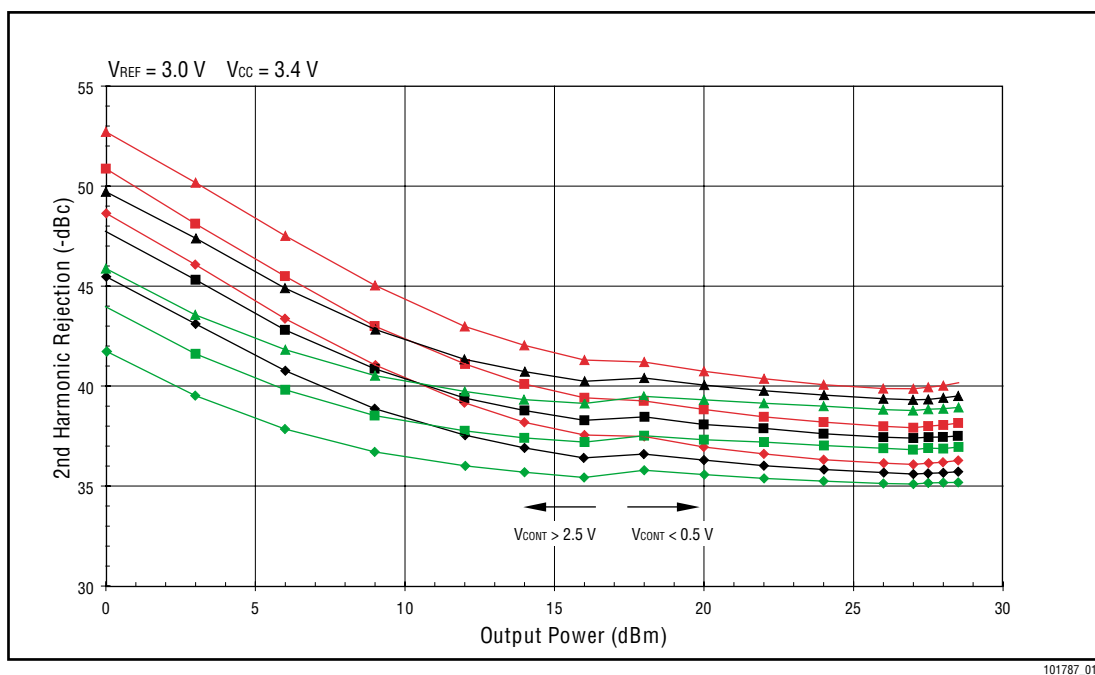
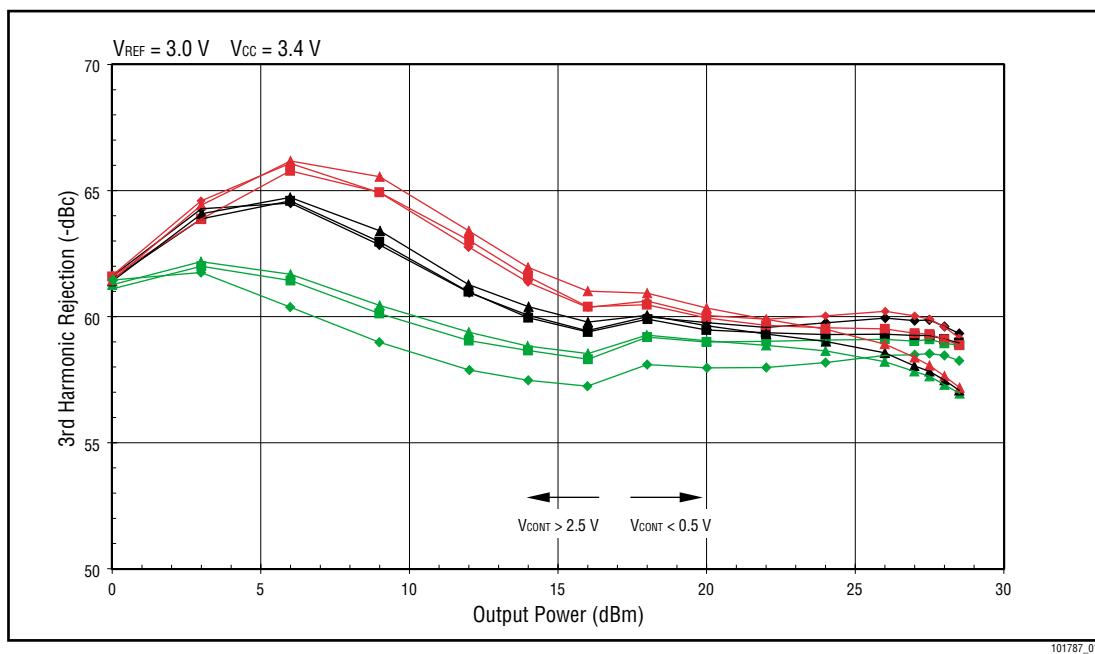

Figure 7. Third Harmonic Rejection vs. Output Power



Legend

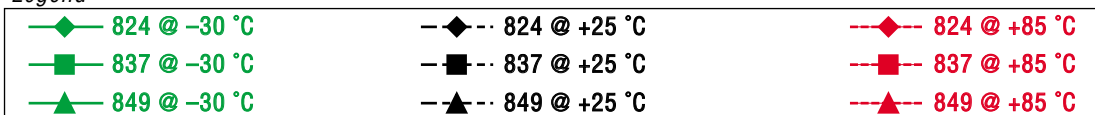
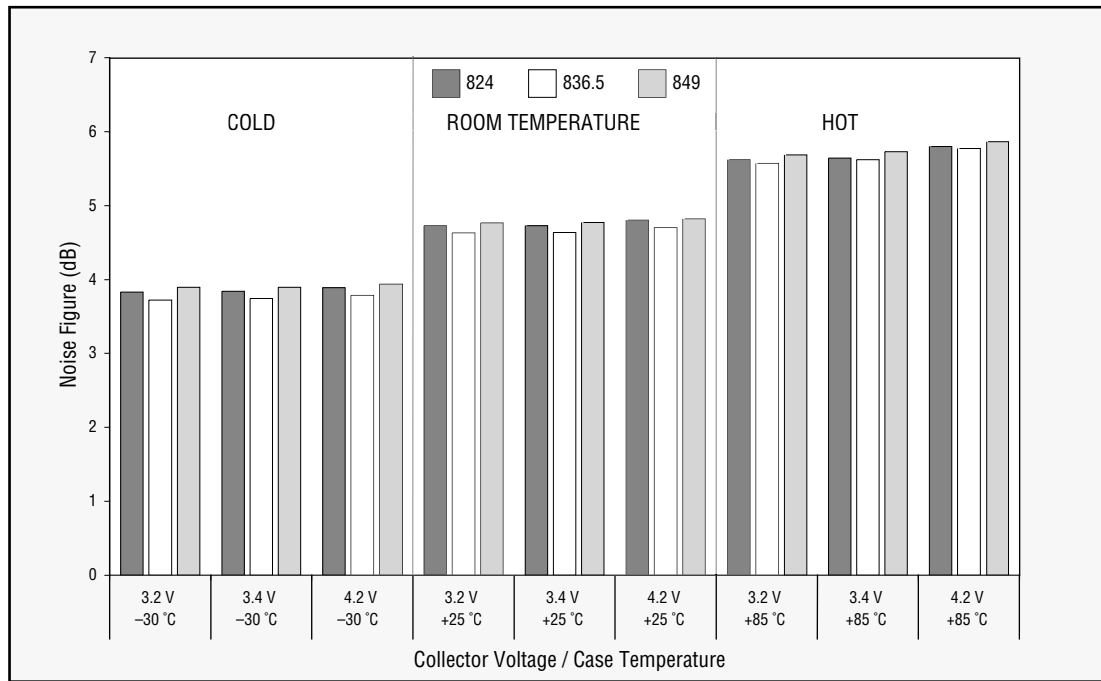
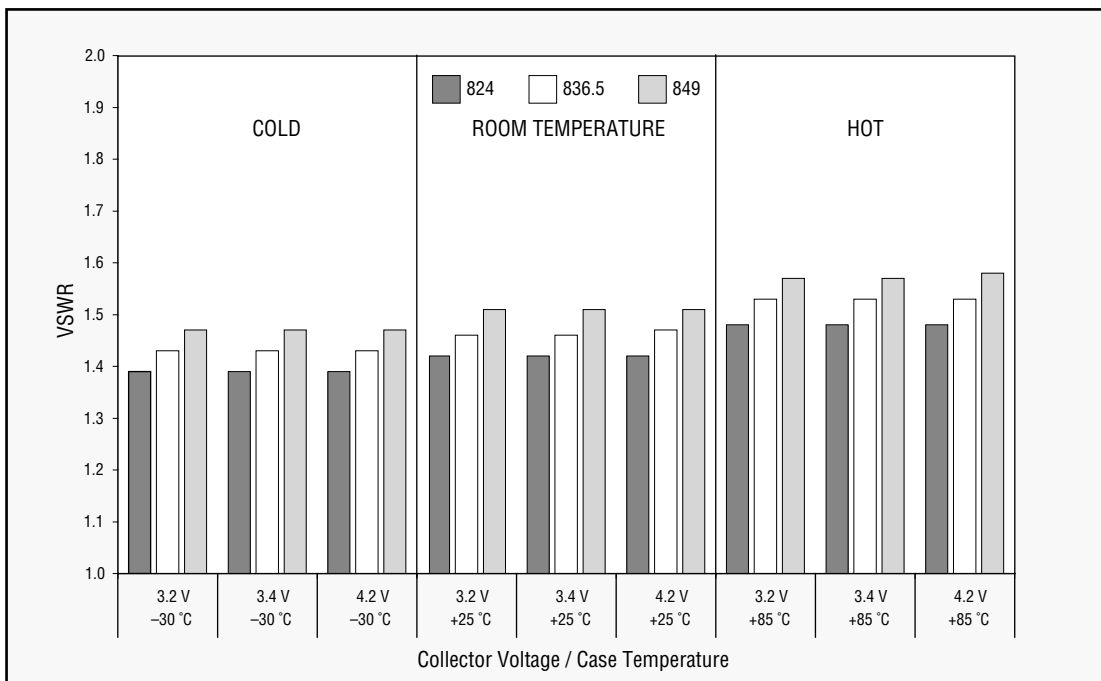

Figure 8. Noise Figure as Function of Operating Conditions



101787_016

Figure 9. Input VSWR as Function of Operating Conditions



101787_017

Evaluation Board Description

The evaluation board is a platform for testing and interfacing design circuitry. To accommodate the interface testing of the CX77105, the evaluation board schematic and diagrams are included for preliminary analysis and design. Figure 10 shows the basic schematic of the board for the 824 MHz to 849 MHz range.

Figure 10. Evaluation Board Schematic

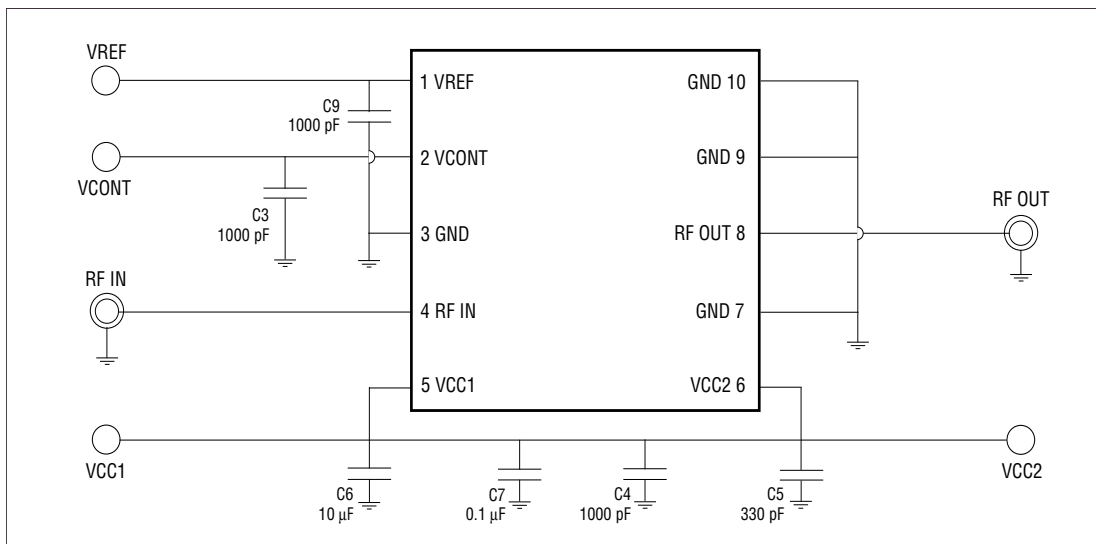

101787_003

Figure 11. Evaluation Board Assembly Diagram

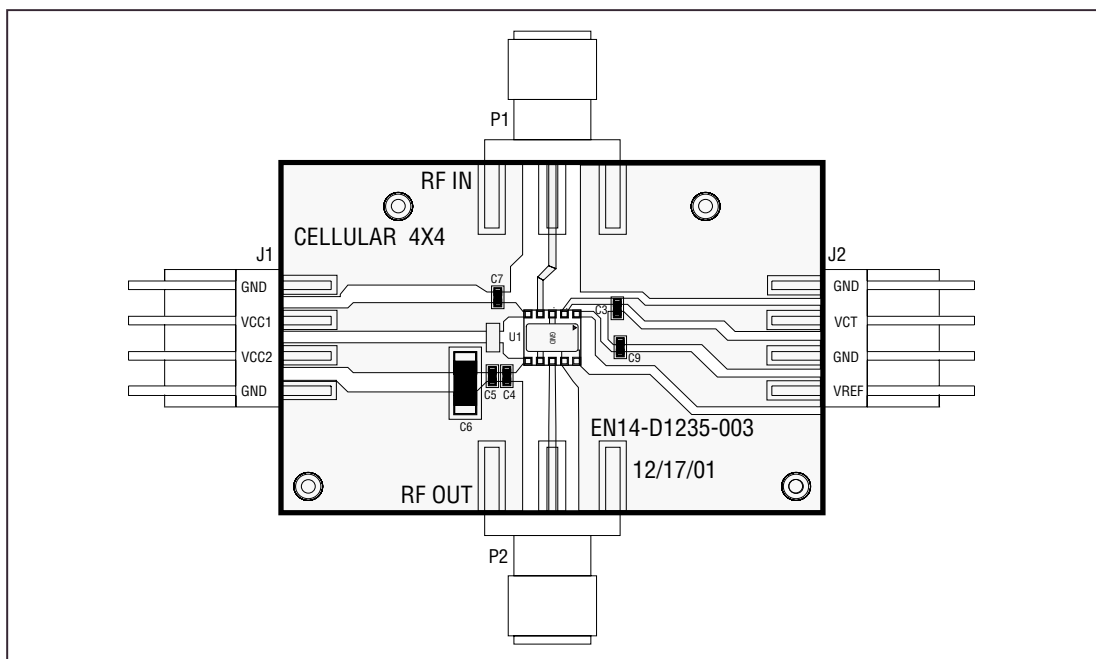

101787_002

Package Dimensions and Pin Descriptions

The CX77105 is a multi-layer laminate base, overmold encapsulated modular package designed for surface mount solder attachment to a printed circuit board.

Figure 12 is a mechanical drawing of the pad layout for this package. The pin numbering convention starts with pin 1 in the upper left, as indicated in Figure 12, and increments counter-clockwise around the package. Table 6 describes each pin function and Figure 13 illustrates typical case markings.

Figure 12. CX77105 Package Dimensional Drawing

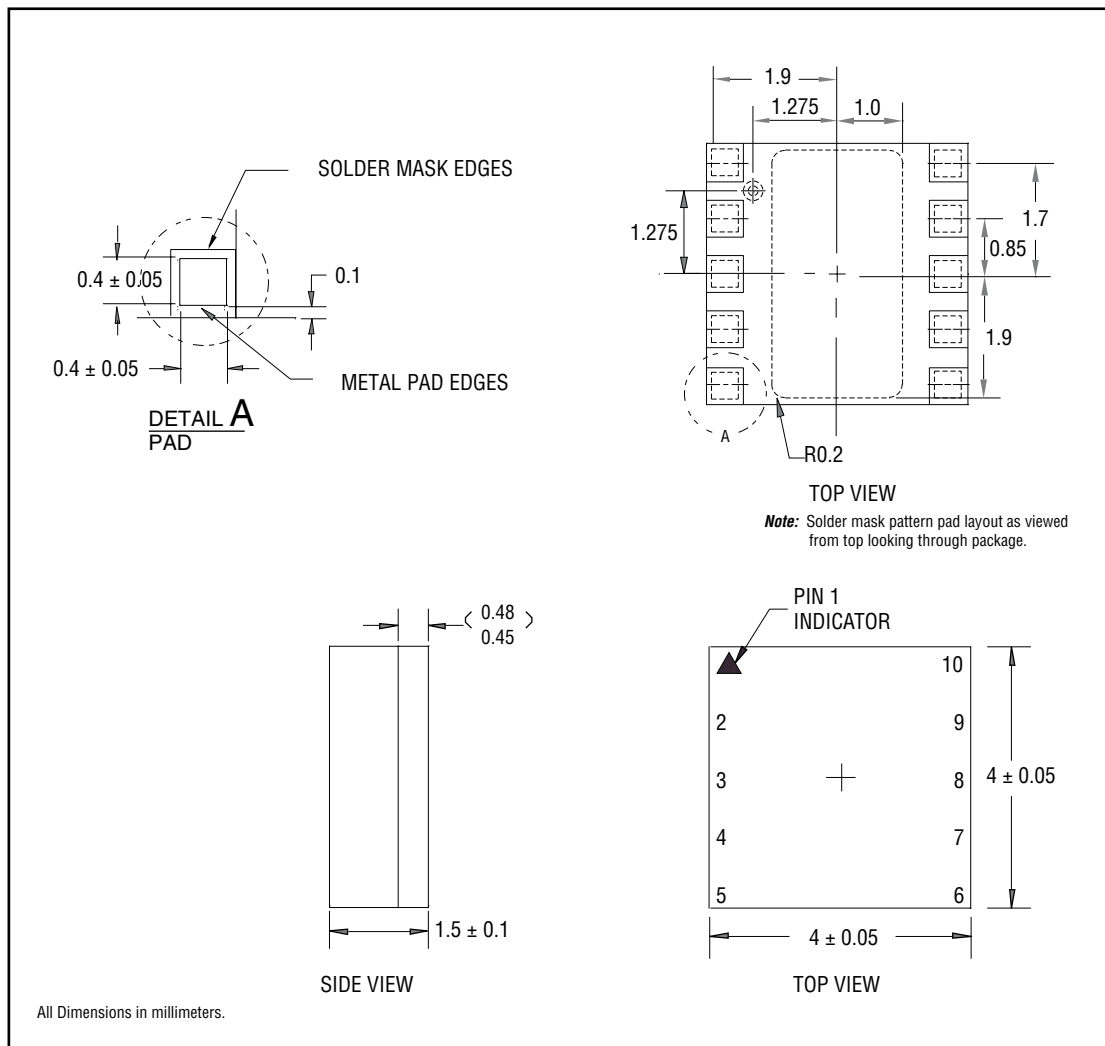

101787_004

Power Amplifier Module for CDMA/AMPS (824–849 MHz)

Table 6. Pin Descriptions

Pin #	Function	Pin #	Function	Pin #	Function
1	VREF	5	VCC1 ⁽¹⁾	9	GND
2	VCONT	6	VCC2 ⁽¹⁾	10	GND
3	GND	7	GND	GND PAD ⁽²⁾	GND
4	RF IN	8	RF OUT		

NOTE(S):
⁽¹⁾ All supply pins may be connected together at the supply.
⁽²⁾ GROUND PAD is package underside.

Figure 13. Typical Case Markings

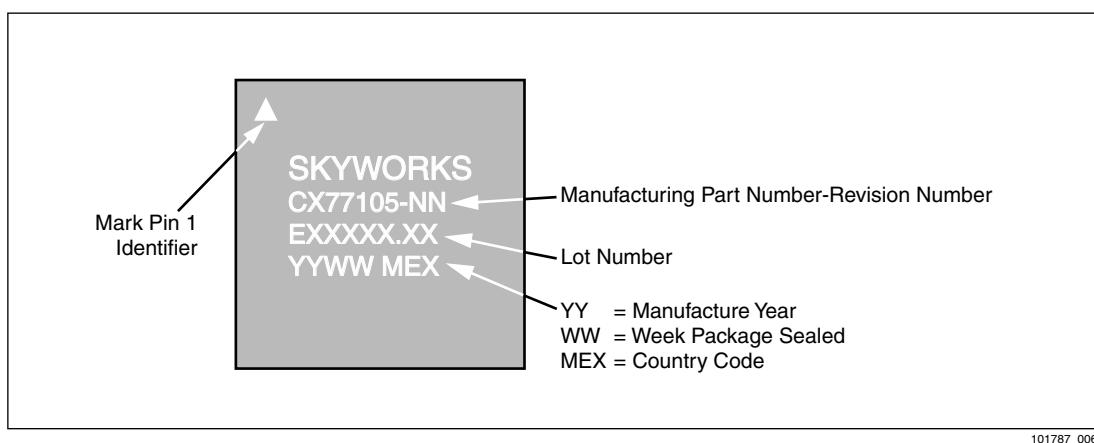

Package and Handling Information

Because of its sensitivity to moisture absorption, this device package is baked and vacuum packed prior to shipment. Instructions on the shipping container label must be followed regarding exposure to moisture after the container seal is broken, otherwise, problems related to moisture absorption may occur when the part is subjected to high temperature during solder assembly.

The CX77105 is capable of withstanding an MSL 3/240 °C solder reflow. Care must be taken when attaching this product, whether it is done manually or in a production solder reflow environment. If the part is attached in a reflow oven, the temperature ramp rate should not exceed 5 °C per second; maximum temperature should not exceed 240 °C. If the part is manually attached, precaution should be taken to insure that the part is not subjected to temperatures exceeding 240 °C for more than 10 seconds. For details on both attachment techniques, precautions, and handling procedures recommended by Skyworks, please refer to *Application Note: PCB Design and SMT Assembly/Rework, Document Number 101752*. Additional information on standard SMT reflow profiles can also be found in the *JEDEC Standard J-STD-020B*.

Production quantities of this product are shipped in the standard tape-and-reel format. For packaging details, refer to *Application Note: Tape and Reel, Document Number 101568*.

Electrostatic Discharge Sensitivity

The CX77105 is a Class I device. Figure 14 lists the Electrostatic Discharge (ESD) immunity level for each pin of the CX77105 product. The numbers in Figure 14 specify the ESD threshold level for each pin where the I-V curve between the pin and ground starts to show degradation. The ESD testing was performed in compliance with MIL-STD-883E Method 3015.7 using the Human Body Model. Since 2000 volts represents the maximum measurement limit of the test equipment used, pins marked > 2000 V pass 2000V ESD stress.

Figure 14. ESD Sensitivity Ares (Top View)

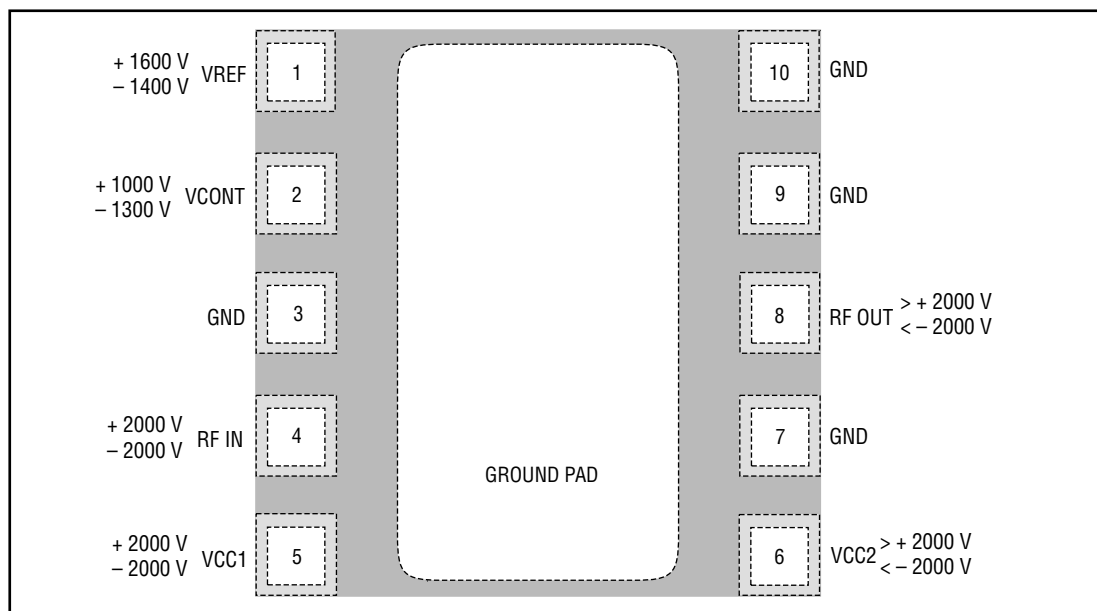

101787_007

Various failure criteria can be utilized when performing ESD testing. Many vendors employ relaxed ESD failure standards which fail devices only after “the pin fails the electrical specification limits” or “the pin becomes completely non-functional”. Skyworks employs most stringent criteria, fails devices as soon as the pin begins to show any degradation on a curve tracer.

To avoid ESD damage, both latent and visible, it is very important that the product assembly and test areas follow the Class-1 ESD handling precautions listed in Table 7.

Table 7. Precautions for GaAs ICs with ESD Thresholds Greater Than 200 V But Less Than 2000 V

<p align="center">Personnel Grounding</p> <p>Wrist Straps Conductive Smocks, Gloves and Finger Cots Antistatic ID Badges</p>	<p align="center">Facility</p> <p>Relative Humidity Control and Air Ionizers Dissipative Floors (less than $10^9 \Omega$ to GND)</p>
<p align="center">Protective Workstation</p> <p>Dissipative Table Tops Protective Test Equipment (Properly Grounded) Grounded Tip Soldering Irons Conductive Solder Suckers Static Sensors</p>	<p align="center">Protective Packaging & Transportation</p> <p>Bags and Pouches (Faraday Shield) Protective Tote Boxes (Conductive Static Shielding) Protective Trays Grounded Carts Protective Work Order Holders</p>

Ordering Information

Model Number	Manufacturing Part Number	Product Revision	Package	Operating Temperature
CX77105	CX77105-16P	16	4x4LM-10	-30 °C to +85 °C

Revision History

Revision	Level	Date	Description
A		December 10, 2002	Initial Release

References

Application Note: PCB Design and SMT Assembly/Rework, Document Number 101752.

Application Note: Tape and Reel, Document Number 101568

JEDEC Standard J-STD-020B.

© 2001, 2002, Skyworks Solutions, Inc. All Rights Reserved.

Information in this document is provided in connection with Skyworks Solutions, Inc. ("Skyworks") products. These materials are provided by Skyworks as a service to its customers and may be used for informational purposes only. Skyworks assumes no responsibility for errors or omissions in these materials. Skyworks may make changes to its products, specifications and product descriptions at any time, without notice. Skyworks makes no commitment to update the information and shall have no responsibility whatsoever for conflicts, incompatibilities, or other difficulties arising from future changes to its products and product descriptions.

No license, express or implied, by estoppel or otherwise, to any intellectual property rights is granted by this document. Except as may be provided in Skyworks' Terms and Conditions of Sale for such products, Skyworks assumes no liability whatsoever.

THESE MATERIALS ARE PROVIDED "AS IS" WITHOUT WARRANTY OF ANY KIND, EITHER EXPRESS OR IMPLIED, RELATING TO SALE AND/OR USE OF SKYWORKS™ PRODUCTS INCLUDING WARRANTIES RELATING TO FITNESS FOR A PARTICULAR PURPOSE, MERCHANTABILITY, PERFORMANCE, QUALITY OR NON-INFRINGEMENT OF ANY PATENT, COPYRIGHT OR OTHER INTELLECTUAL PROPERTY RIGHT. SKYWORKS FURTHER DOES NOT WARRANT THE ACCURACY OR COMPLETENESS OF THE INFORMATION, TEXT, GRAPHICS OR OTHER ITEMS CONTAINED WITHIN THESE MATERIALS. SKYWORKS SHALL NOT BE LIABLE FOR ANY SPECIAL, INDIRECT, INCIDENTAL, OR CONSEQUENTIAL DAMAGES, INCLUDING WITHOUT LIMITATION, LOST REVENUES OR LOST PROFITS THAT MAY RESULT FROM THE USE OF THESE MATERIALS.

Skyworks™ products are not intended for use in medical, lifesaving or life-sustaining applications. Skyworks' customers using or selling Skyworks™ products for use in such applications do so at their own risk and agree to fully indemnify Skyworks for any damages resulting from such improper use or sale.

The following are trademarks of Skyworks Solutions, Inc.: Skyworks™, the Skyworks symbol, and "Breakthrough Simplicity"™. Product names or services listed in this publication are for identification purposes only, and may be trademarks of third parties. Third-party brands and names are the property of their respective owners.

Additional information, posted at www.skyworksinc.com, is incorporated by reference.

General Information:
Skyworks Solutions, Inc.
4311 Jamboree Rd.
Newport Beach, CA. 92660-3007
www.skyworksinc.com

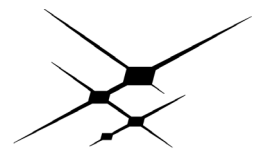

SKYWORKS[™]
BREAKTHROUGH SIMPLICITY