

SG300(R,U,W,EX)11 SG300(R,U,W,EX)12

GATE TURN-OFF THYRISTOR

CHOPPER, INVERTER APPLICATION

- Repetitive Peak Off-State Voltage
: $V_{DRM}=1300, 1600, 1800, 2500V$
- R.M.S On-State Current : $I_T(RMS)=120A$
- Peak Turn-Off Current : $I_{TGQM}=300A$
- Critical Rate of Rise of On-State Current
: $di/dt=200A/\mu s$
- Critical Rate of Rise of Off-State Voltage
: $dv/dt=600V/\mu s$

MAXIMUM RATINGS

CHARACTERISTIC		SYMBOL	RATING	UNIT
Repetitive Peak Off-State Voltage	SG300R(11,12)	V _{DRM}	1300	V
	SG300U(11,12)		1600	
	SG300W(11,12)		1800	
	SG300EX(11,12)		2500	
Repetitive Peak Reverse Voltage		V _{RRM}	15	V
Peak Turn-Off Current (Note 1)		I _{TGQM}	300	A
R.M.S On-State Current (Note 2)		I _{T(RMS)}	120	A
Peak One Cycle Surge On-State Current (Non-Repetitive)		I _{TSM}	2000(50Hz)	A
			2200(60Hz)	
Critical Rate of Rise of On-State Current (Note 3)		di/dt	200	A/μs
Peak Forward Gate Current (Note 4)		I _{FGM}	20	A
Average Forward Gate Power Dissipation		P _{G(AV)}	4	W
R.M.S Reverse Gate Current		I _{RG(RMS)}	20	A
Peak Reverse Gate Power Dissipation (Note 5)		P _{RGM}	2	kW
Peak Reverse Gate Voltage		V _{RGM}	15	V
Storage Temperature Range		T _{stg}	-40~125	°C
Operating Junction Temperature Range		T _j	-40~125	°C
Screw Torque (M5)		-	20	kg·cm

Note 1 : $V_D=1/2$ Rated, $V_{DM}=2/3$ Rated, $C_S=1\mu F$, $R_S=20\Omega$,
 $di/dt=12A/\mu s$, $I_{RG}=80A$, $T_j=125^\circ C$, ($V_{DSP} \leq 400V$)

Note 2 : Half Sine Waveform, $T_f=70^\circ C$

Note 3 : $V_D=1/2$ Rated, $I_{TM}=300A$, $I_G=7A$, $t_r=1\mu s$, $f=50Hz$
 $T_j=125^\circ C$

Note 4 : Pulse Width : Max. 20μs, Duty : Max. 20%

Note 5 : Pulse Width : Max. 20μs, Duty : Max. 2%

Unit in mm

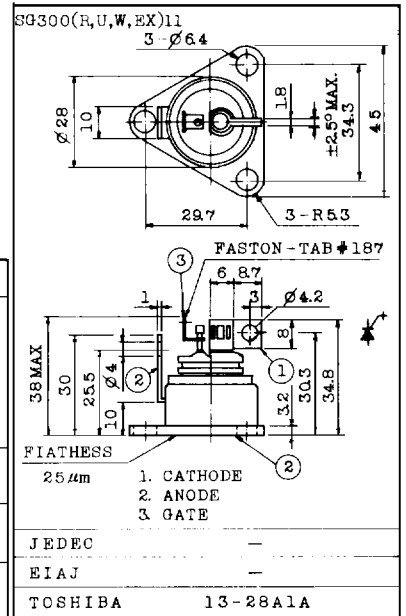

Weight : 90 g

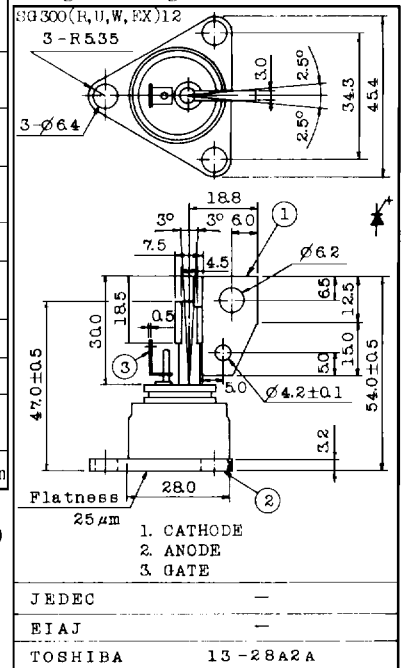

Weight : 95 g

ELECTRICAL CHARACTERISTICS

CHARACTERISTIC		SYMBOL	TEST CONDITION	MIN.	TYP.	MAX.	UNIT	
Repetitive Peak Off-State Current		I _{DRM}	V _{DRM} =Rated, R _{GK} =20Ω T _j =125°C	-	-	10	mA	
Repetitive Peak Reverse Current		I _{RRM}	V _{RRM} =Rated, T _j =125°C	-	-	10	mA	
Repetitive Peak Reverse Gate Current		I _{RCM}	V _{RCM} =Rated, T _j =125°C	-	-	10	mA	
Peak On-State Voltage		V _{TM}	I _{TM} =300A, T _c =25°C	-	-	2.4	V	
Gate Trigger Voltage		V _{GT}	V _D =12V	T _c =-40°C	-	-	1.5	V
				T _c =25°C	-	0.75	1.0	
Gate Trigger Current		I _{GT}	R _L =0.5Ω	T _c =-40°C	-	-	1500	mA
				T _c =25°C	-	200	500	
Gate Non-Trigger Voltage		V _{GD}	V _D =1/2 Rated, T _c =125°C	0.3	-	-	V	
Gate Non-Trigger Current		I _{GD}		5	-	-	mA	
Delay Time		t _d		-	-	2.5	μs	
Turn-On Time		t _{gt}	V _D =1/2 Rated di/dt=200A/μs I _{TM} =300A I _G =7A, t _r =1μs T _c =25°C		-	-	7.6	μs
					-	-	7.0	
					-	-	6.8	
					-	-	6.0	
Critical Rate of Rise of Off-State Voltage		dv/dt	V _{DRM} =2/3 Rated T _j =125°C, V _{GK} =-2V Exponential Rise	600	-	-	V/μs	
Holding Current		I _H	T _c =25°C, R _L =0.5Ω	-	10	-	A	
Storage Time		t _s	I _T =300A V _D =1/2 Rated V _{DM} =2/3 Rated C _S =1μF di _{RG} /dt=-12A/μs T _c =120°C	-	-	12	μs	
Gate Turn-Off Time		t _{gq}		-	-	14	μs	
Tail Time		t _{tail}			-	-	62	μs
					-	-	58	
					-	-	56	
					-	-	50	
Turn-Off Gate Current		I _{RG}		-	80	110	A	
Thermal Resistance		R _{th(j-c)}	Junction to Case	-	-	0.13	°C/W	

Note. Contact Thermal Resistance R_{th(c-f)}=0.07°C/W
 (Applied silicone grease)

SG300(R,U,W,EX)11 SG300(R,U,W,EX)12

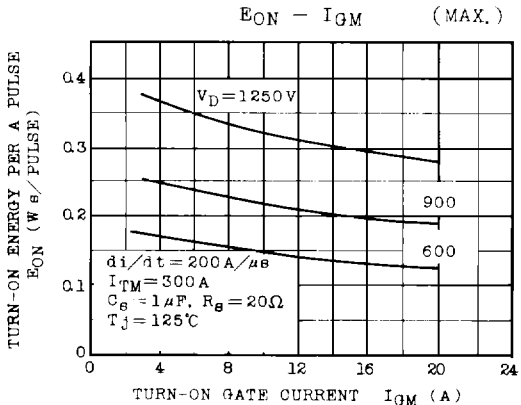
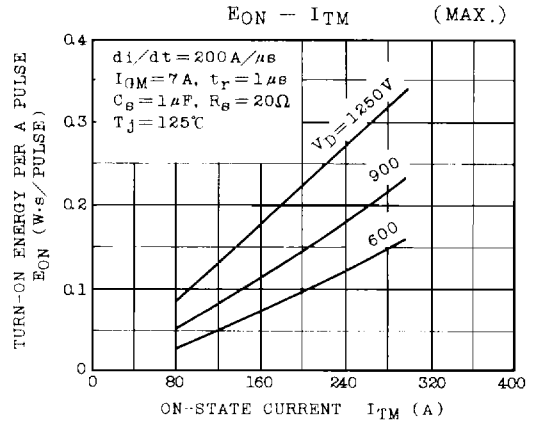
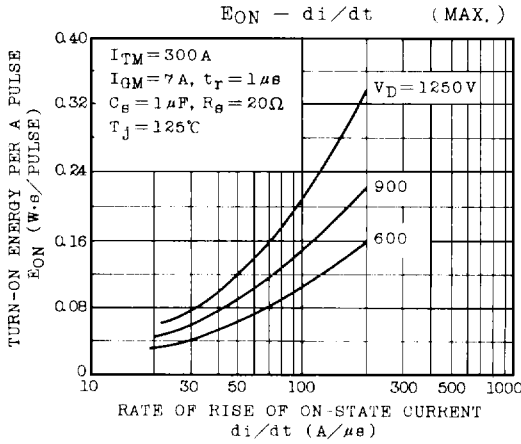
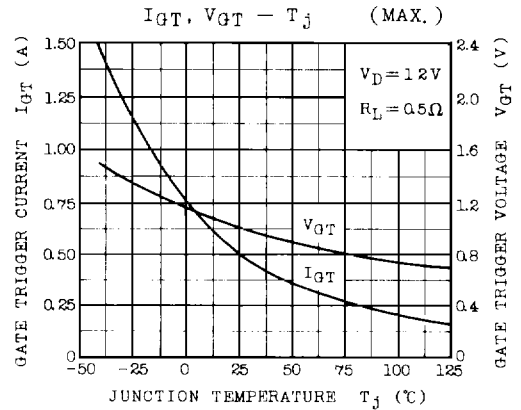
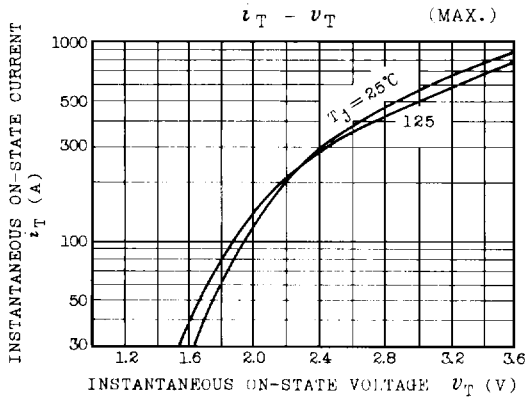

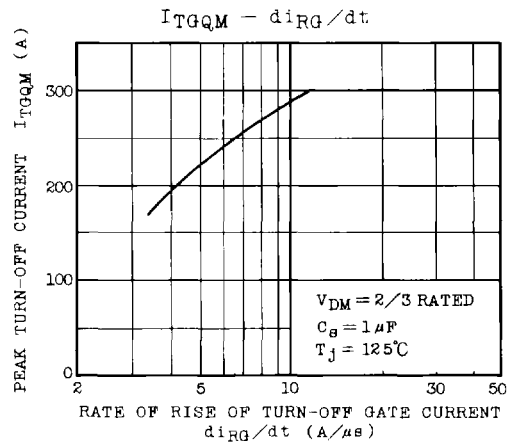
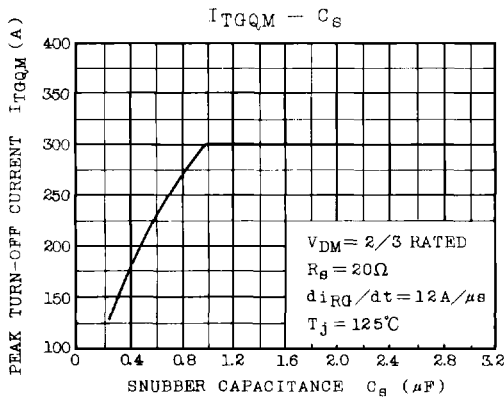
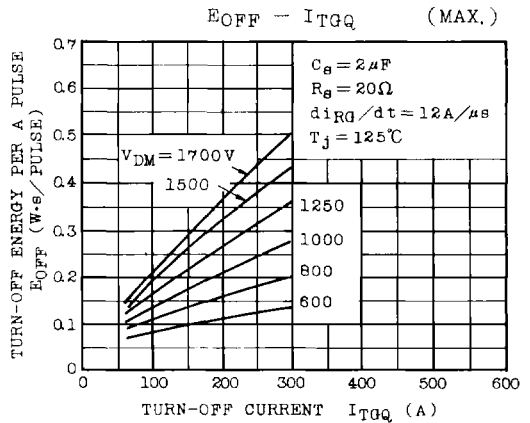
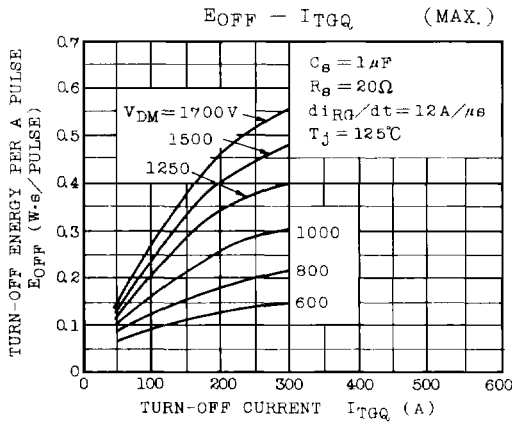
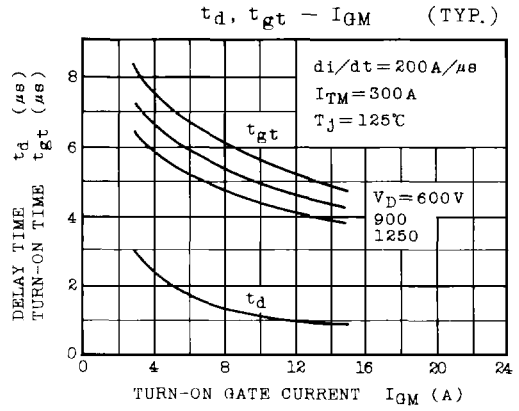
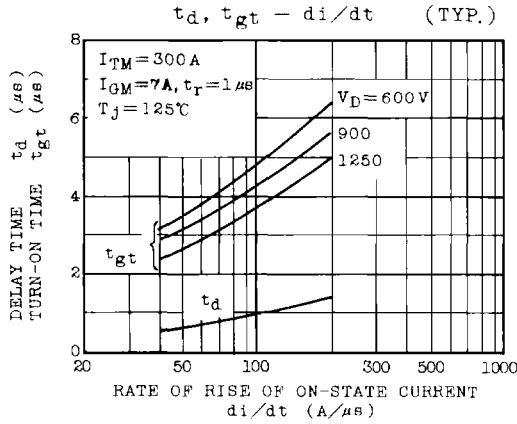

SG300(R, U, W, EX)11

SG300(R, U, W, EX)12

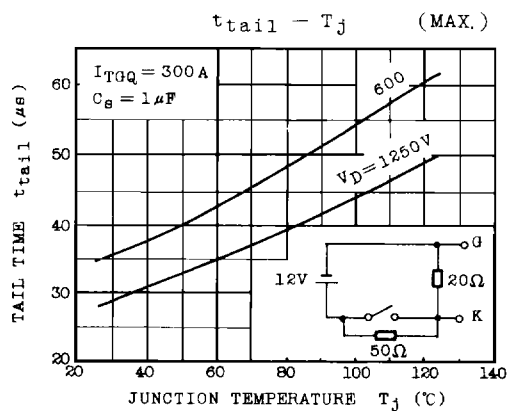
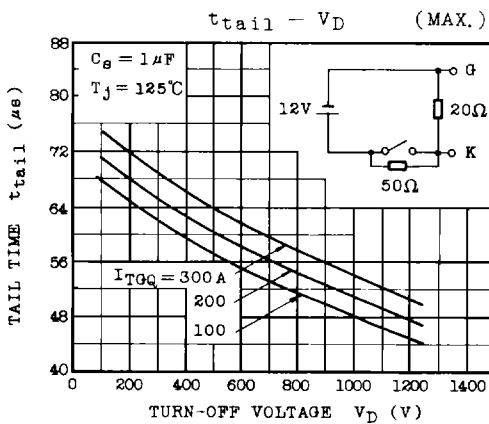
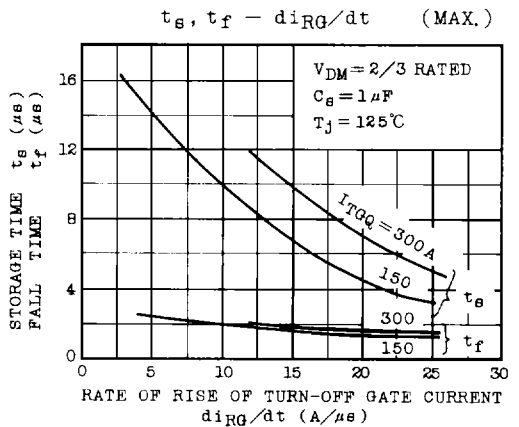
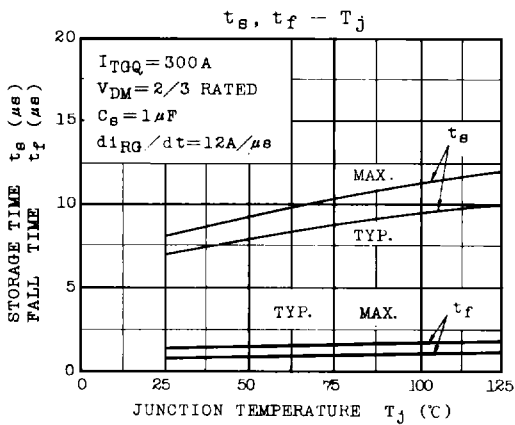
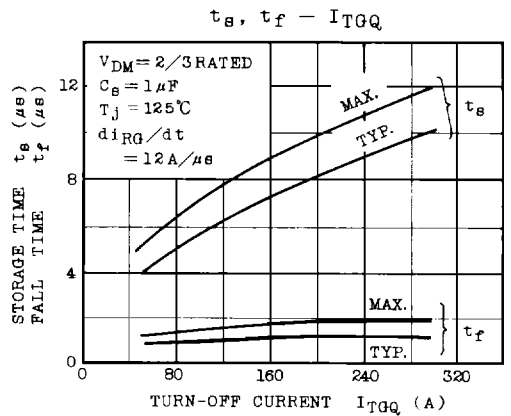
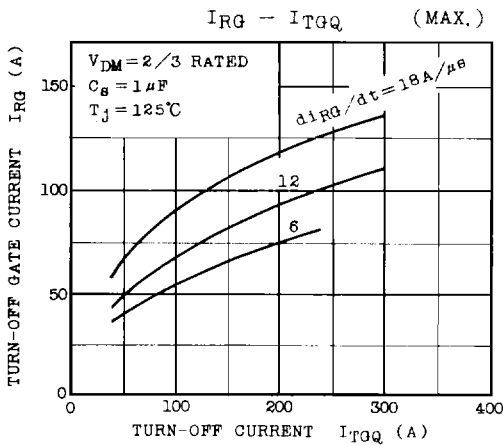

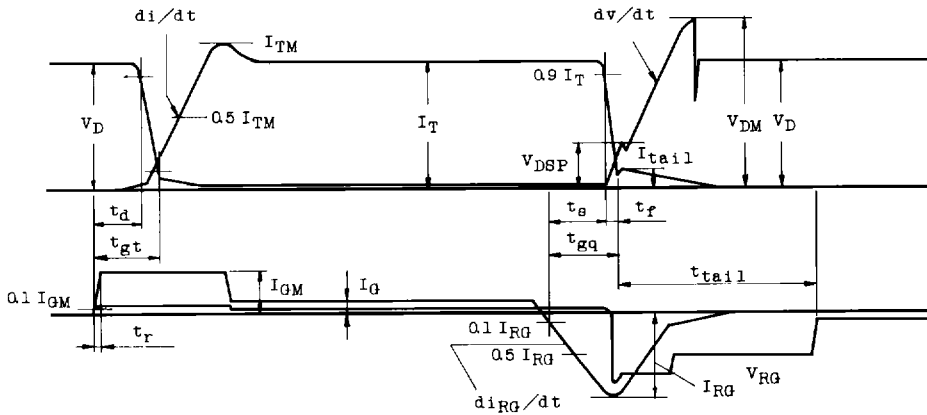
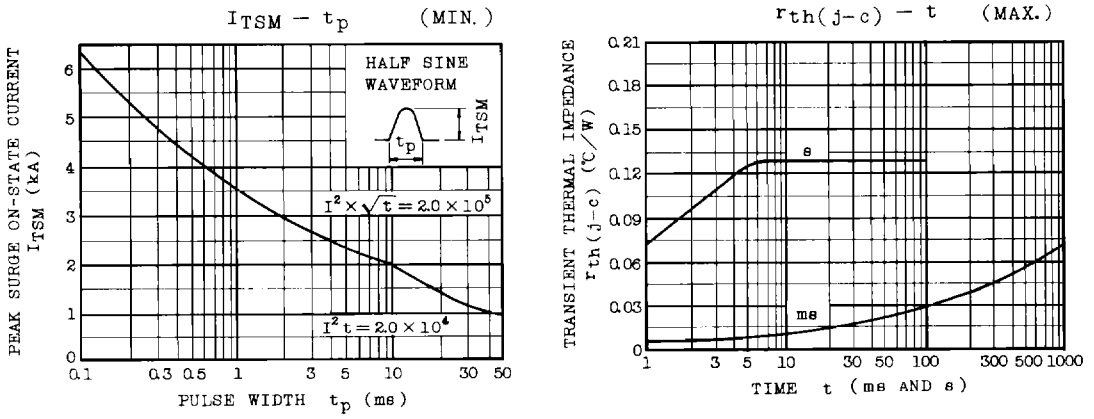

Fig. 1 TURN-ON AND TURN-OFF CHARACTERISTIC OF GTO