

OneNAND SPECIFICATION

Product	Part No.	Vcc(core & IO)	Temperature	PKG
OneNAND128	KFG2816Q1M-DEB	1.8V(1.7V~1.95V)	Extended	67FBGA(LF)/48TSOP1
	KFG2816U1M-DIB	3.3V(2.7V~3.6V)	Industrial	67FBGA(LF)/48TSOP1

Version: Ver. 1.1
Date: Dec. 23, 2005

INFORMATION IN THIS DOCUMENT IS PROVIDED IN RELATION TO SAMSUNG PRODUCTS, AND IS SUBJECT TO CHANGE WITHOUT NOTICE. NOTHING IN THIS DOCUMENT SHALL BE CONSTRUED AS GRANTING ANY LICENSE, EXPRESS OR IMPLIED, BY ESTOPPEL OR OTHERWISE, TO ANY INTELLECTUAL PROPERTY RIGHTS IN SAMSUNG PRODUCTS OR TECHNOLOGY. ALL INFORMATION IN THIS DOCUMENT IS PROVIDED ON AS "AS IS" BASIS WITHOUT GUARANTEE OR WARRANTY OF ANY KIND.

1. For updates or additional information about Samsung products, contact your nearest Samsung office.
2. Samsung products are not intended for use in life support, critical care, medical, safety equipment, or similar applications where Product failure could result in loss of life or personal or physical harm, or any military or defense application, or any governmental procurement to which special terms or provisions may apply.

OneNAND™, is a trademark of Samsung Electronics Company, Ltd. Other names and brands may be claimed as the property of their rightful owners.

Copyright © 2005, Samsung Electronics Company, Ltd

Document Title

OneNAND

Revision History

<u>Revision No.</u>	<u>History</u>	<u>Draft Date</u>	<u>Remark</u>
0.0	1. Initial Issue.	Sep. 9, 2004	Advance
0.1	1. Corrected the errata 2. Revised Cold Reset 3. Added TSOP1 Package Information 4. Revised FBGA package type 5. Added 67FBGA Package Information 6. Revised typical tOTP, tLOCK from 300us to 600us 7. Revised max tOTP, tLOCK from 600us to 1000us 8. Deleted Lock All Block, Lock-Tight All Block Operation 9. Added Endurance and Data Retention 10. Revised Load Data into Buffer Operation Sequence 11. Revised Warm Reset 12. Revised Programmable Burst Read Latency Timing Diagram 13. Revised Multi Block Erase Flow Chart 14. Revised Extended Operating Temperature	Oct. 28, 2004	Advance
1.0	1. Added Copyright Notice in the beginning 2. Corrected Errata 3. Updated lcc2, lcc4, lcc5, lcc6 and I _{SB} 4. Revised INT pin description 5. Added OTP erase case NOTE 6. Revised case definitions of Interrupt Status Register 7. Added a NOTE to Command register 8. Added ECClogSector Information table 9. Removed 'data unit based data handling' from description of Device Operation 10. Revised description on Warm/Hot/NAND Flash Core Reset 11. Revised Warm Reset Timing 12. Revised description for 4-, 8-, 16-, 32-Word Linear Burst Mode 13. Revised OTP operation description 14. Added note for OTP _T in Internal Register Reset 15. Removed all block lock default case after cold or warm reset 16. Added explanation for each prohibited case in protect mode 17. Revised the case of writing other commands during Multi Block Erase routine 18. Added note for Erase Suspend/Resume 19. Added supplemental explanation for ECC Operation 20. Removed classification of ECC error from ECC Operation 21. Removed redundant sentence from ECC Bypass Operation 22. Added technical note for Boot Sequence 23. Added technical note for INT pin connection guide 24. Excluded tOE _H from Asynchronous Read Table 25. Revised Asynchronous Read timing diagram for $\overline{\text{CE}}$ don't care mode 26. Revised Asynchronous Write timing diagram for $\overline{\text{CE}}$ don't care mode 27. Revised Load operation timing diagram for $\overline{\text{CE}}$ don't care mode	Jun. 15, 2005	

The attached datasheets are prepared and approved by SAMSUNG Electronics. SAMSUNG Electronics CO., LTD. reserve the right to change the specifications. SAMSUNG Electronics will evaluate and reply to your requests and questions about device. If you have any questions, please contact the SAMSUNG branch office near you.

Document Title

OneNAND

Revision History

<u>Revision No.</u>	<u>History</u>	<u>Draft Date</u>	<u>Remark</u>
1.1	<ol style="list-style-type: none">1. Corrected the errata.2. Deleted a 2.65V option.3. Chapter 7.16 : Add more explanation about cases according to BSC setting.4. Asynchronous Write Operation : Modified a parameter name from 'WE Pulse Width' to 'WE Pulse Width Low'.5. Technical Note(Method of determining Interrupt status) : Modified description and pin connection.	Dec. 23, 2005	Final

The attached datasheets are prepared and approved by SAMSUNG Electronics. SAMSUNG Electronics CO., LTD. reserve the right to change the specifications. SAMSUNG Electronics will evaluate and reply to your requests and questions about device. If you have any questions, please contact the SAMSUNG branch office near you.

1. FEATURES

◆ Architecture

- Design Technology: 0.12 μ m
- Voltage Supply
 - 1.8V device(KFG2816Q1M) : 1.7V~1.95V
 - 3.3V device(KFG2816U1M) : 2.7V~3.6V
- Organization
 - Host Interface:16bit
- Internal BufferRAM(3K Bytes)
 - 1KB for BootRAM, 2KB for DataRAM
- NAND Array
 - Page Size : (1K+32)bytes
 - Block Size : (64K+2K)bytes

◆ Performance

- Host Interface type
 - Synchronous Burst Read
 - : Clock Frequency: up to 54MHz
 - : Linear Burst - 4 , 8 , 16 , 32 words with wrap-around
 - : Continuous Sequential Burst(512 words)
 - Asynchronous Random Read
 - : Access time of 76ns
 - Asynchronous Random Write
- Programmable Read latency
- Multiple Sector Read
 - Read multiple sectors by Sector Count Register(up to 2 sectors)
- Multiple Reset
 - Cold Reset / Warm Reset / Hot Reset / NAND Flash Reset
- Power dissipation (typical values, C_L=30pF)
 - Standby current : 10 μ A@1.8V device, 15 μ A@3.3V device
 - Synchronous Burst Read current(54MHz) : 12mA@1.8V device, 20mA@3.3V device
 - Load current : 20mA@1.8V device, 20mA@3.3V device
 - Program current: 20mA@1.8V device, 20mA@3.3V device
 - Erase current: 15mA@1.8V device, 18mA@3.3V device
- Reliable CMOS Floating-Gate Technology
 - Endurance : 100K Program/Erase Cycles
 - Data Retention : 10 Years

◆ Hardware Features

- Voltage detector generating internal reset signal from V_{cc}
- Hardware reset input (RP)
- Data Protection
 - Write Protection mode for BootRAM
 - Write Protection mode for NAND Flash Array
 - Write protection during power-up
 - Write protection during power-down
- User-controlled One Time Programmable(OTP) area
- Internal 2bit EDC / 1bit ECC
- Internal Bootloader supports Booting Solution in system

◆ Software Features

- Handshaking Feature
 - INT pin: Indicates Ready / Busy of OneNAND
 - Polling method: Provides a software method of detecting the Ready / Busy status of OneNAND
- Detailed chip information by ID register

◆ Packaging

- Package
 - 67ball, 7mm x 9mm x max 1.0mm, 0.8mm ball pitch FBGA
 - 48 TSOP 1, 12mm x 20mm, 0.5mm pitch

2. GENERAL DESCRIPTION

OneNAND is a single-die chip with standard NOR Flash interface using NAND Flash Array. This device is comprised of logic and NAND Flash Array and 3KB internal BufferRAM. 1KB BootRAM is used for reserving bootcode, and 2KB DataRAM is used for buffering data. The operating clock frequency is up to 54MHz. This device is X16 interface with Host, and has the speed of ~76ns random access time. Actually, it is accessible with minimum 4clock latency(host-driven clock for synchronous read), but this device adopts the appropriate wait cycles by programmable read latency. OneNAND provides the multiple sector read operation by assigning the number of sectors to be read in the sector counter register. The device includes one block sized OTP(One Time Programmable), which can be used to increase system security or to provide identification capabilities.

3. PIN DESCRIPTION

Pin Name	Type	Name and Description
Host Interface		
A15~A0	I	Address Inputs - Inputs for addresses during operation, which are for addressing BufferRAM & Register.
DQ15~DQ0	I/O	Data Inputs/Outputs - Inputs data during program and commands during all operations, outputs data during memory array/register read cycles. Data pins float to high-impedance when the chip is deselected or outputs are disabled.
INT	O	Interrupt Notifying Host when a command has completed. It is open drain output with internal resistor (~50kohms). After power-up, it is at hi-z condition. Once IOBE is set to 1, it does not float to hi-z condition even when the chip is deselected or when outputs are disabled.
RDY	O	Ready Indicates data valid in synchronous read modes and is activated while \overline{CE} is low
CLK	I	Clock CLK synchronizes the device to the system bus frequency in synchronous read mode. The first rising edge of CLK in conjunction with \overline{AVD} low latches address input.
\overline{WE}	I	Write Enable \overline{WE} controls writes to the bufferRAM and registers. Data are latched on the \overline{WE} pulse's rising edge
\overline{AVD}	I	Address Valid Detect Indicates valid address presence on address inputs. During asynchronous read operation, all addresses are latched on \overline{AVD} 's rising edge, and during synchronous read operation, all addresses are latched on CLK's rising edge while \overline{AVD} is held low for one clock cycle. > Low : for asynchronous mode, indicates valid address ;for burst mode, causes starting address to be latched on rising edge on CLK > High : device ignores address inputs
\overline{RP}	I	Reset Pin When low, \overline{RP} resets internal operation of OneNAND. \overline{RP} status is don't care during power-up and bootloading.
\overline{CE}	I	Chip Enable \overline{CE} -low activates internal control logic, and \overline{CE} -high deselected the device, places it in standby state, and places ADD and DQ in Hi-Z
\overline{OE}	I	Output Enable \overline{OE} -low enables the device's output data buffers during a read cycle.
Power Supply		
Vcc-Core/Vcc		Power for OneNAND Core This is the power supply for OneNAND Core.
Vcc-IO/Vccq		Power for OneNAND I/O This is the power supply for OneNAND I/O Vcc-IO is internally connected to Vcc-Core, thus should be connected to the same power supply.
Vss		Ground for OneNAND
etc.		
DNU		Do Not Use Leave it disconnected. These pins are used for testing.
NC		No Connection Lead is not internally connected.

NOTE:
Do not leave power supply(VCC, VSS) disconnected.

4. PIN CONFIGURATION

4.1 TSOP1



(TOP VIEW, Facing Down)

TSOP1 OneNAND Chip

48pin, 12mm x 20mm, 0.5mm pitch TSOP1

4.2 67FBGA

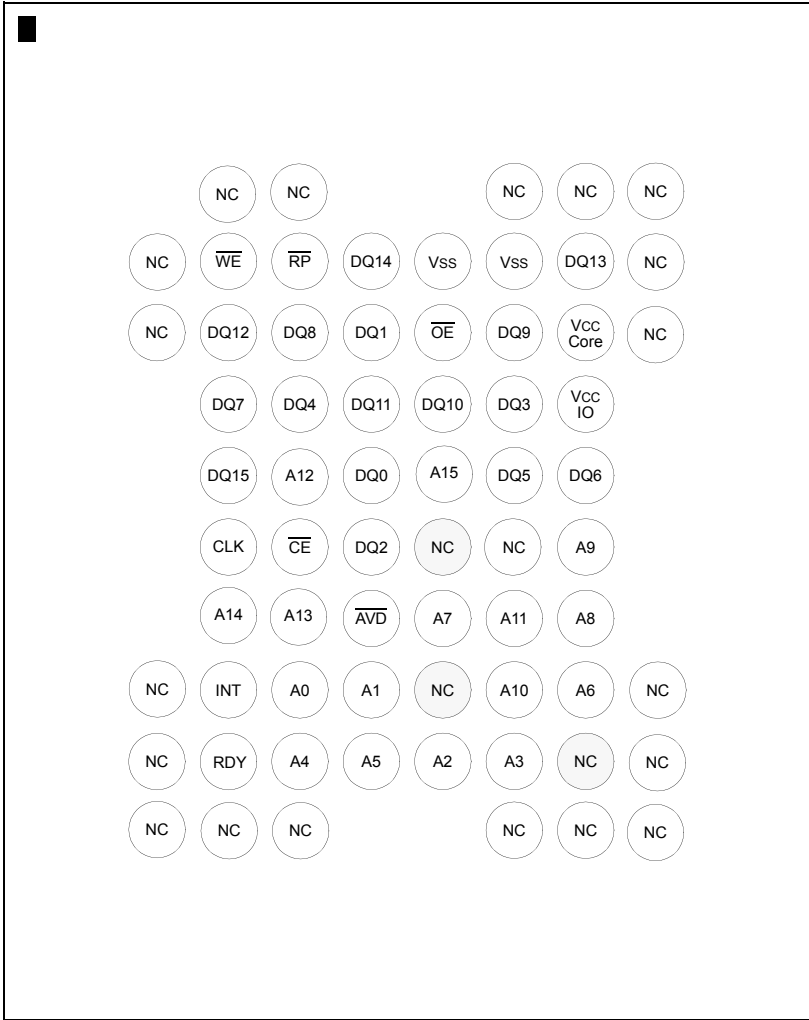

(TOP VIEW, Balls Facing Down)

67ball FBGA OneNAND Chip

67ball, 7.0mm x 9.0mm x max 1.0mm, 0.8mm ball pitch FBGA

TERMS, ABBREVIATIONS AND DEFINITIONS

B (capital letter)	Byte, 8bits
W (capital letter)	Word, 16bits
b (lower-case letter)	Bit
ECC	Error Correction Code
Calculated ECC	ECC which has been calculated during load or program access
Written ECC	ECC which has been stored as data in the NAND Flash Array or in the BufferRAM
BufferRAM	On-chip Internal Buffer consisting of BootRAM and DataRAM
BootRAM	A 1KB portion of the BufferRAM reserved for Bootcode buffering
DataRAM	A 2KB portion of the BufferRAM reserved for Data buffering
Memory	NAND Flash array which is embedded on OneNAND
Sector	Partial unit of page, of which size is 512B for main area and 16B for spare area data. It is the minimum Load/Program/Copy-Back program unit while one~two sector operation is available
Data unit	Possible data unit to be read from memory to BufferRAM or to be programmed to memory. - 528B of which 512B is in main area and 16B in spare area - 1056B of which 1024B is in main area and 32B in spare area

5. BLOCK DIAGRAM

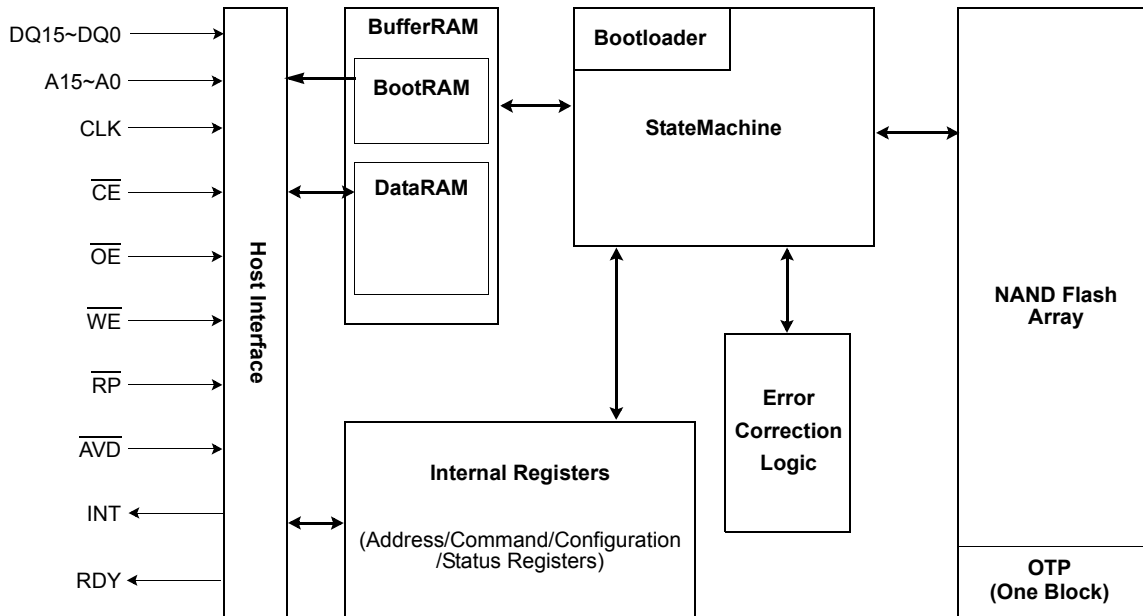

- Host Interface
- BufferRAM(BootRAM, DataRAM)
- Command and status registers
- State Machine (Bootloader is included)
- Error Correction Logic
- Memory(NAND Flash Array, OTP)

NOTE:

1) At cold reset, bootloader copies boot code(1K byte size) from NAND Flash Array to BootRAM.

Figure 1. Internal Block Diagram

6. ADDRESS MAP For OneNAND NAND Array (word order)

Block	Block Address	Page and Sector Address ⁽¹⁾	Size	Block	Block Address	Page and Sector Address ⁽¹⁾	Size
Block0	0000h	0000h~00FDh	64KB	Block32	0020h	0000h~00FDh	64KB
Block1	0001h	0000h~00FDh	64KB	Block33	0021h	0000h~00FDh	64KB
Block2	0002h	0000h~00FDh	64KB	Block34	0022h	0000h~00FDh	64KB
Block3	0003h	0000h~00FDh	64KB	Block35	0023h	0000h~00FDh	64KB
Block4	0004h	0000h~00FDh	64KB	Block36	0024h	0000h~00FDh	64KB
Block5	0005h	0000h~00FDh	64KB	Block37	0025h	0000h~00FDh	64KB
Block6	0006h	0000h~00FDh	64KB	Block38	0026h	0000h~00FDh	64KB
Block7	0007h	0000h~00FDh	64KB	Block39	0027h	0000h~00FDh	64KB
Block8	0008h	0000h~00FDh	64KB	Block40	0028h	0000h~00FDh	64KB
Block9	0009h	0000h~00FDh	64KB	Block41	0029h	0000h~00FDh	64KB
Block10	000Ah	0000h~00FDh	64KB	Block42	002Ah	0000h~00FDh	64KB
Block11	000Bh	0000h~00FDh	64KB	Block43	002Bh	0000h~00FDh	64KB
Block12	000Ch	0000h~00FDh	64KB	Block44	002Ch	0000h~00FDh	64KB
Block13	000Dh	0000h~00FDh	64KB	Block45	002Dh	0000h~00FDh	64KB
Block14	000Eh	0000h~00FDh	64KB	Block46	002Eh	0000h~00FDh	64KB
Block15	000Fh	0000h~00FDh	64KB	Block47	002Fh	0000h~00FDh	64KB
Block16	0010h	0000h~00FDh	64KB	Block48	0030h	0000h~00FDh	64KB
Block17	0011h	0000h~00FDh	64KB	Block49	0031h	0000h~00FDh	64KB
Block18	0012h	0000h~00FDh	64KB	Block50	0032h	0000h~00FDh	64KB
Block19	0013h	0000h~00FDh	64KB	Block51	0033h	0000h~00FDh	64KB
Block20	0014h	0000h~00FDh	64KB	Block52	0034h	0000h~00FDh	64KB
Block21	0015h	0000h~00FDh	64KB	Block53	0035h	0000h~00FDh	64KB
Block22	0016h	0000h~00FDh	64KB	Block54	0036h	0000h~00FDh	64KB
Block23	0017h	0000h~00FDh	64KB	Block55	0037h	0000h~00FDh	64KB
Block24	0018h	0000h~00FDh	64KB	Block56	0038h	0000h~00FDh	64KB
Block25	0019h	0000h~00FDh	64KB	Block57	0039h	0000h~00FDh	64KB
Block26	001Ah	0000h~00FDh	64KB	Block58	003Ah	0000h~00FDh	64KB
Block27	001Bh	0000h~00FDh	64KB	Block59	003Bh	0000h~00FDh	64KB
Block28	001Ch	0000h~00FDh	64KB	Block60	003Ch	0000h~00FDh	64KB
Block29	001Dh	0000h~00FDh	64KB	Block61	003Dh	0000h~00FDh	64KB
Block30	001Eh	0000h~00FDh	64KB	Block62	003Eh	0000h~00FDh	64KB
Block31	001Fh	0000h~00FDh	64KB	Block63	003Fh	0000h~00FDh	64KB

NOTE 1) The 2nd bit of Page and Sector address register is Don't care. So the address range is bigger than the real range. Even though 2nd bit is set to "1", this bit is always considered "0". Please refer to Start Address 8 register.

Block	Block Address	Page and Sector Address ⁽¹⁾	Size	Block	Block Address	Page and Sector Address ⁽¹⁾	Size
Block64	0040h	0000h~00FDh	64KB	Block96	0060h	0000h~00FDh	64KB
Block65	0041h	0000h~00FDh	64KB	Block97	0061h	0000h~00FDh	64KB
Block66	0042h	0000h~00FDh	64KB	Block98	0062h	0000h~00FDh	64KB
Block67	0043h	0000h~00FDh	64KB	Block99	0063h	0000h~00FDh	64KB
Block68	0044h	0000h~00FDh	64KB	Block100	0064h	0000h~00FDh	64KB
Block69	0045h	0000h~00FDh	64KB	Block101	0065h	0000h~00FDh	64KB
Block70	0046h	0000h~00FDh	64KB	Block102	0066h	0000h~00FDh	64KB
Block71	0047h	0000h~00FDh	64KB	Block103	0067h	0000h~00FDh	64KB
Block72	0048h	0000h~00FDh	64KB	Block104	0068h	0000h~00FDh	64KB
Block73	0049h	0000h~00FDh	64KB	Block105	0069h	0000h~00FDh	64KB
Block74	004Ah	0000h~00FDh	64KB	Block106	006Ah	0000h~00FDh	64KB
Block75	004Bh	0000h~00FDh	64KB	Block107	006Bh	0000h~00FDh	64KB
Block76	004Ch	0000h~00FDh	64KB	Block108	006Ch	0000h~00FDh	64KB
Block77	004Dh	0000h~00FDh	64KB	Block109	006Dh	0000h~00FDh	64KB
Block78	004Eh	0000h~00FDh	64KB	Block110	006Eh	0000h~00FDh	64KB
Block79	004Fh	0000h~00FDh	64KB	Block111	006Fh	0000h~00FDh	64KB
Block80	0050h	0000h~00FDh	64KB	Block112	0070h	0000h~00FDh	64KB
Block81	0051h	0000h~00FDh	64KB	Block113	0071h	0000h~00FDh	64KB
Block82	0052h	0000h~00FDh	64KB	Block114	0072h	0000h~00FDh	64KB
Block83	0053h	0000h~00FDh	64KB	Block115	0073h	0000h~00FDh	64KB
Block84	0054h	0000h~00FDh	64KB	Block116	0074h	0000h~00FDh	64KB
Block85	0055h	0000h~00FDh	64KB	Block117	0075h	0000h~00FDh	64KB
Block86	0056h	0000h~00FDh	64KB	Block118	0076h	0000h~00FDh	64KB
Block87	0057h	0000h~00FDh	64KB	Block119	0077h	0000h~00FDh	64KB
Block88	0058h	0000h~00FDh	64KB	Block120	0078h	0000h~00FDh	64KB
Block89	0059h	0000h~00FDh	64KB	Block121	0079h	0000h~00FDh	64KB
Block90	005Ah	0000h~00FDh	64KB	Block122	007Ah	0000h~00FDh	64KB
Block91	005Bh	0000h~00FDh	64KB	Block123	007Bh	0000h~00FDh	64KB
Block92	005Ch	0000h~00FDh	64KB	Block124	007Ch	0000h~00FDh	64KB
Block93	005Dh	0000h~00FDh	64KB	Block125	007Dh	0000h~00FDh	64KB
Block94	005Eh	0000h~00FDh	64KB	Block126	007Eh	0000h~00FDh	64KB
Block95	005Fh	0000h~00FDh	64KB	Block127	007Fh	0000h~00FDh	64KB

NOTE 1) 2nd bit of Page and Sector address is Don't care. So the address range is bigger than the real range.
Even though 2nd bit is set to "1", this bit is always considered "0". Please refer to Start Address 8 register.

Block	Block Address	Page and Sector Address ⁽¹⁾	Size	Block	Block Address	Page and Sector Address ⁽¹⁾	Size
Block128	0080h	0000h~00FDh	64KB	Block160	00A0h	0000h~00FDh	64KB
Block129	0081h	0000h~00FDh	64KB	Block161	00A1h	0000h~00FDh	64KB
Block130	0082h	0000h~00FDh	64KB	Block162	00A2h	0000h~00FDh	64KB
Block131	0083h	0000h~00FDh	64KB	Block163	00A3h	0000h~00FDh	64KB
Block132	0084h	0000h~00FDh	64KB	Block164	00A4h	0000h~00FDh	64KB
Block133	0085h	0000h~00FDh	64KB	Block165	00A5h	0000h~00FDh	64KB
Block134	0086h	0000h~00FDh	64KB	Block166	00A6h	0000h~00FDh	64KB
Block135	0087h	0000h~00FDh	64KB	Block167	00A7h	0000h~00FDh	64KB
Block136	0088h	0000h~00FDh	64KB	Block168	00A8h	0000h~00FDh	64KB
Block137	0089h	0000h~00FDh	64KB	Block169	00A9h	0000h~00FDh	64KB
Block138	008Ah	0000h~00FDh	64KB	Block170	00AAh	0000h~00FDh	64KB
Block139	008Bh	0000h~00FDh	64KB	Block171	00ABh	0000h~00FDh	64KB
Block140	008Ch	0000h~00FDh	64KB	Block172	00ACh	0000h~00FDh	64KB
Block141	008Dh	0000h~00FDh	64KB	Block173	00ADh	0000h~00FDh	64KB
Block142	008Eh	0000h~00FDh	64KB	Block174	00AEh	0000h~00FDh	64KB
Block143	008Fh	0000h~00FDh	64KB	Block175	00AFh	0000h~00FDh	64KB
Block144	0090h	0000h~00FDh	64KB	Block176	00B0h	0000h~00FDh	64KB
Block145	0091h	0000h~00FDh	64KB	Block177	00B1h	0000h~00FDh	64KB
Block146	0092h	0000h~00FDh	64KB	Block178	00B2h	0000h~00FDh	64KB
Block147	0093h	0000h~00FDh	64KB	Block179	00B3h	0000h~00FDh	64KB
Block148	0094h	0000h~00FDh	64KB	Block180	00B4h	0000h~00FDh	64KB
Block149	0095h	0000h~00FDh	64KB	Block181	00B5h	0000h~00FDh	64KB
Block150	0096h	0000h~00FDh	64KB	Block182	00B6h	0000h~00FDh	64KB
Block151	0097h	0000h~00FDh	64KB	Block183	00B7h	0000h~00FDh	64KB
Block152	0098h	0000h~00FDh	64KB	Block184	00B8h	0000h~00FDh	64KB
Block153	0099h	0000h~00FDh	64KB	Block185	00B9h	0000h~00FDh	64KB
Block154	009Ah	0000h~00FDh	64KB	Block186	00BAh	0000h~00FDh	64KB
Block155	009Bh	0000h~00FDh	64KB	Block187	00BBh	0000h~00FDh	64KB
Block156	009Ch	0000h~00FDh	64KB	Block188	00BCh	0000h~00FDh	64KB
Block157	009Dh	0000h~00FDh	64KB	Block189	00BDh	0000h~00FDh	64KB
Block158	009Eh	0000h~00FDh	64KB	Block190	00BEh	0000h~00FDh	64KB
Block159	009Fh	0000h~00FDh	64KB	Block191	00BFh	0000h~00FDh	64KB

NOTE 1) 2nd bit of Page and Sector address is Don't care. So the address range is bigger than the real range.
Even though 2nd bit is set to "1", this bit is always considered "0". Please refer to Start Address 8 register.

Block	Block Address	Page and Sector Address ⁽¹⁾	Size	Block	Block Address	Page and Sector Address ⁽¹⁾	Size
Block192	00C0h	0000h~00FDh	64KB	Block224	00E0h	0000h~00FDh	64KB
Block193	00C1h	0000h~00FDh	64KB	Block225	00E1h	0000h~00FDh	64KB
Block194	00C2h	0000h~00FDh	64KB	Block226	00E2h	0000h~00FDh	64KB
Block195	00C3h	0000h~00FDh	64KB	Block227	00E3h	0000h~00FDh	64KB
Block196	00C4h	0000h~00FDh	64KB	Block228	00E4h	0000h~00FDh	64KB
Block197	00C5h	0000h~00FDh	64KB	Block229	00E5h	0000h~00FDh	64KB
Block198	00C6h	0000h~00FDh	64KB	Block230	00E6h	0000h~00FDh	64KB
Block199	00C7h	0000h~00FDh	64KB	Block231	00E7h	0000h~00FDh	64KB
Block200	00C8h	0000h~00FDh	64KB	Block232	00E8h	0000h~00FDh	64KB
Block201	00C9h	0000h~00FDh	64KB	Block233	00E9h	0000h~00FDh	64KB
Block202	00CAh	0000h~00FDh	64KB	Block234	00EAh	0000h~00FDh	64KB
Block203	00CBh	0000h~00FDh	64KB	Block235	00EBh	0000h~00FDh	64KB
Block204	00CCh	0000h~00FDh	64KB	Block236	00ECh	0000h~00FDh	64KB
Block205	00CDh	0000h~00FDh	64KB	Block237	00EDh	0000h~00FDh	64KB
Block206	00CEh	0000h~00FDh	64KB	Block238	00EEh	0000h~00FDh	64KB
Block207	00CFh	0000h~00FDh	64KB	Block239	00EFh	0000h~00FDh	64KB
Block208	00D0h	0000h~00FDh	64KB	Block240	00F0h	0000h~00FDh	64KB
Block209	00D1h	0000h~00FDh	64KB	Block241	00F1h	0000h~00FDh	64KB
Block210	00D2h	0000h~00FDh	64KB	Block242	00F2h	0000h~00FDh	64KB
Block211	00D3h	0000h~00FDh	64KB	Block243	00F3h	0000h~00FDh	64KB
Block212	00D4h	0000h~00FDh	64KB	Block244	00F4h	0000h~00FDh	64KB
Block213	00D5h	0000h~00FDh	64KB	Block245	00F5h	0000h~00FDh	64KB
Block214	00D6h	0000h~00FDh	64KB	Block246	00F6h	0000h~00FDh	64KB
Block215	00D7h	0000h~00FDh	64KB	Block247	00F7h	0000h~00FDh	64KB
Block216	00D8h	0000h~00FDh	64KB	Block248	00F8h	0000h~00FDh	64KB
Block217	00D9h	0000h~00FDh	64KB	Block249	00F9h	0000h~00FDh	64KB
Block218	00DAh	0000h~00FDh	64KB	Block250	00FAh	0000h~00FDh	64KB
Block219	00DBh	0000h~00FDh	64KB	Block251	00FBh	0000h~00FDh	64KB
Block220	00DCh	0000h~00FDh	64KB	Block252	00FCh	0000h~00FDh	64KB
Block221	00DDh	0000h~00FDh	64KB	Block253	00FDh	0000h~00FDh	64KB
Block222	00DEh	0000h~00FDh	64KB	Block254	00FEh	0000h~00FDh	64KB
Block223	00DFh	0000h~00FDh	64KB	Block255	00FFh	0000h~00FDh	64KB

NOTE 1) 2nd bit of Page and Sector address is Don't care. So the address range is bigger than the real range.
Even though 2nd bit is set to "1", this bit is always considered "0". Please refer to Start Address 8 register.

Detailed information of Address Map (word order)

• BootRAM(Main area)

-0000h~01FFh: 2(sector) x 512byte(NAND main area) = 1KB

0000h~00FFh(512B) BootM 0 (sector 0 of page 0)	0100h~01FFh(512B) BootM 1 (sector 1 of page 0)
--	--

• DataRAM(Main area)

-0200h~05FFh: 4(sector) x 512byte(NAND main area) = 2KB

0200h~02FFh(512B) DataM 0_0 (sector 0 of page 0)	0300h~03FFh(512B) DataM 0_1 (sector 1 of page 0)	0400h~04FFh(512B) DataM 1_0 (sector 0 of page 1)	0500h~05FFh(512B) DataM 1_1 (sector 1 of page 1)
--	--	--	--

• BootRAM(Spare area)

-8000h~800Fh: 2(sector) x 16byte(NAND spare area) = 32B

8000h~8007h(16B) BootS 0 (sector 0 of page 0)	8008h~800Fh(16B) BootS 1 (sector 1 of page 0)
---	---

• DataRAM(Spare area)

-8010h~802Fh: 4(sector) x 16byte(NAND spare area) = 64B

8010h~8017h(16B) DataS 0_0 (sector 0 of page 0)	8018h~801Fh(16B) DataS 0_1 (sector 1 of page 0)	8020h~8027h(16B) DataS 1_0 (sector 0 of page 1)	8028h~802Fh(16B) DataS 1_1 (sector 1 of page 1)
---	---	---	---

*NAND Flash array consists of 1KB page size and 64KB block size.

Spare area assignment

← Equivalent to 1word of NAND Flash →

Buf.	Word Address	Byte Address	F	E	D	C	B	A	9	8	7	6	5	4	3	2	1	0
BootS 0	8000h	10000h	BI															
	8001h	10002h	Managed by Internal ECC logic															
	8002h	10004h	Reserved for the future use								Managed by Internal ECC logic							
	8003h	10006h	Reserved for the current and future use															
	8004h	10008h	ECC Code for Main area data (2 nd)								ECC Code for Main area data (1 st)							
	8005h	1000Ah	ECC Code for Spare area data (1 st)								ECC Code for Main area data (3 rd)							
	8006h	1000Ch	FFh(Reserved for the future use)								ECC Code for Spare area data (2 nd)							
	8007h	1000Eh	Free Usage															
BootS 1	8008h	10010h	BI															
	8009h	10012h	Managed by Internal ECC logic															
	800Ah	10014h	Reserved for the future use								Managed by Internal ECC logic							
	800Bh	10016h	Reserved for the current and future use															
	800Ch	10018h	ECC Code for Main area data (2 nd)								ECC Code for Main area data (1 st)							
	800Dh	1001Ah	ECC Code for Spare area data (1 st)								ECC Code for Main area data (3 rd)							
	800Eh	1001Ch	FFh(Reserved for the future use)								ECC Code for Spare area data (2 nd)							
	800Fh	1001Eh	Free Usage															
DataS 0_0	8010h	10020h	BI															
	8011h	10022h	Managed by Internal ECC logic															
	8012h	10024h	Reserved for the future use								Managed by Internal ECC logic							
	8013h	10026h	Reserved for the current and future use															
	8014h	10028h	ECC Code for Main area data (2 nd)								ECC Code for Main area data (1 st)							
	8015h	1002Ah	ECC Code for Spare area data (1 st)								ECC Code for Main area data (3 rd)							
	8016h	1002Ch	FFh(Reserved for the future use)								ECC Code for Spare area data (2 nd)							
	8017h	1002Eh	Free Usage															
DataS 0_1	8018h	10030h	BI															
	8019h	10032h	Managed by Internal ECC logic															
	801Ah	10034h	Reserved for the future use								Managed by Internal ECC logic							
	801Bh	10036h	Reserved for the current and future use															
	801Ch	10038h	ECC Code for Main area data (2 nd)								ECC Code for Main area data (1 st)							
	801Dh	1003Ah	ECC Code for Spare area data (1 st)								ECC Code for Main area data (3 rd)							
	801Eh	1003Ch	FFh(Reserved for the future use)								ECC Code for Spare area data (2 nd)							
	801Fh	1003Eh	Free Usage															

← Equivalent to 1word of NAND Flash →

Buf.	Word Address	Byte Address	F	E	D	C	B	A	9	8	7	6	5	4	3	2	1	0
DataS 1_0	8020h	10040h	BI															
	8021h	10042h	Managed by Internal ECC logic															
	8022h	10044h	Reserved for the future use								Managed by Internal ECC logic							
	8023h	10046h	Reserved for the current and future use															
	8024h	10048h	ECC Code for Main area data (2 nd)								ECC Code for Main area data (1 st)							
	8025h	1004Ah	ECC Code for Spare area data (1 st)								ECC Code for Main area data (3 rd)							
	8026h	1004Ch	FFh(Reserved for the future use)								ECC Code for Spare area data (2 nd)							
	8027h	1004Eh	Free Usage															
DataS 1_1	8028h	10050h	BI															
	8029h	10052h	Managed by Internal ECC logic															
	802Ah	10054h	Reserved for the future use								Managed by Internal ECC logic							
	802Bh	10056h	Reserved for the current and future use															
	802Ch	10058h	ECC Code for Main area data (2 nd)								ECC Code for Main area data (1 st)							
	802Dh	1005Ah	ECC Code for Spare area data (1 st)								ECC Code for Main area data (3 rd)							
	802Eh	1005Ch	FFh(Reserved for the future use)								ECC Code for Spare area data (2 nd)							
	802Fh	1005Eh	Free Usage															

NOTE:

- BI: Invalid block Information

- >Host can use complete spare area except BI and ECC code area. For example, Host can write data to Spare area buffer except for the area controlled by ECC logic at program operation.
- >OneNAND automatically generates ECC code for both main and spare data of memory during program operation in case of 'with ECC' mode , but does not update ECC code to spare bufferRAM.
- >When loading/programming spare area, spare area BufferRAM address(BSA) and BufferRAM sector count(BSC) is chosen via Start buffer register as it is.

7. Detailed address map for registers

Address (word order)	Address (byte order)	Name	Host Access	Description
F000h	1E000h	Manufacturer ID	R	Manufacturer identification
F001h	1E002h	Device ID	R	Device identification
F002h	1E004h	Version ID	R	Version identification
F003h	1E006h	Data Buffer size	R	Data buffer size
F004h	1E008h	Boot Buffer size	R	Boot buffer size
F005h	1E00Ah	Amount of buffers	R	Amount of data/boot buffers
F006h	1E00Ch	Technology	R	Info about technology
F007h~F0FFh	1E00Eh~1E1FEh	Reserved	-	Reserved for User
F100h	1E200h	Start address 1	R/W	NAND Flash Block address
F101h	1E202h	Start address 2	R/W	Reserved
F102h	1E204h	Start address 3	R/W	Destination Block address for Copy back program
F103h	1E206h	Start address 4	R/W	Destination Page & Sector address for Copy back program
F104h	1E208h	Start address 5	-	N/A
F105h	1E20Ah	Start address 6	-	N/A
F106h	1E20Ch	Start address 7	-	N/A
F107h	1E20Eh	Start address 8	R/W	NAND Flash Page & Sector address
F108h~F1FFh	1E210h~1E3FEh	Reserved	-	Reserved for User
F200h	1E400h	Start Buffer	R/W	Number Buffer of for the page data transfer to/from the memory and the start Buffer Address The meaning is with which buffer to start and how many buffers to use for the data transfer
F201h~F207h	1E402h~1E40Eh	Reserved	-	Reserved for User
F208h~F21Fh	1E410h~1E43Eh	Reserved	-	Reserved for vendor specific purposes
F220h	1E440h	Command	R/W	Host control and memory operation commands
F221h	1E442h	System Configuration 1	R, R/W	Memory and Host Interface Configuration
F222h	1E444h	System Configuration 2	-	N/A
F223h~F22Fh	1E446h~1E45Eh	Reserved	-	Reserved for User
F230h~F23Fh	1E460h~1E47Eh	Reserved	-	Reserved for vendor specific purposes
F240h	1E480h	Controller Status	R	Controller Status and result of memory operation
F241h	1E482h	Interrupt	R/W	Memory Command Completion Interrupt Status
F242h~F24Bh	1E484h~1E496h	Reserved	-	Reserved for User
F24Ch	1E498h	Unlock Start Block Address	R/W	Start memory block address to unlock in Write Protection mode
F24Dh	1E49Ah	Unlock End Block Address	R/W	End memory block address to unlock in Write Protection mode
F24Eh	1E49Ch	Write Protection Status	R	Current memory Write Protection status (unlocked/locked/tight-locked)
F24Fh~FEFFh	1E49Eh~1FD FEh	Reserved	-	Reserved for User

Address (word order)	Address (byte order)	Name	Host Access	Description
FF00h	1FE00h	ECC Status Register	R	ECC status of sector
FF01h	1FE02h	ECC Result of main area data	R	ECC error position of Main area data error for first selected Sector
FF02h	1FE04h	ECC Result of spare area data	R	ECC error position of Spare area data error for first selected Sector
FF03h	1FE06h	ECC Result of main area data	R	ECC error position of Main area data error for second selected Sector
FF04h	1FE08h	ECC Result of spare area data	R	ECC error position of Spare area data error for second selected Sector
FF05h~FFFFh	1FE12h~1FF0Ah	Reserved	-	Reserved for vendor specific purposes

7. Address Register (word order)

7.1 Manufacturer ID Register (R): F000h, default=00ECh

15	14	13	12	11	10	9	8	7	6	5	4	3	2	1	0
ManufID															

ManufID (Manufacturer ID): manufacturer identification, 00ECh for Samsung Electronics Corp.

7.2 Device ID Register (R): F001h, default=refer to Table1

15	14	13	12	11	10	9	8	7	6	5	4	3	2	1	0
DeviceID															

DeviceID (Device ID): Device Identification,

Table 1.

Device	DeviceID[15:0]
KFG2816Q1M	0004h
KFG2816U1M	0005h

7.3 Version ID Register (R): F002h

: N/A

7.4 Data Buffer size Register(R): F003h, default=0400h

15	14	13	12	11	10	9	8	7	6	5	4	3	2	1	0
DataBufSize															

DataBufSize: total data buffer size in words in the memory interface used for shrinks
 Equals two buffers of 512 words each($2 \times 512 = 2^N$, $N=10$)

7.5 Boot Buffer size Register (R): F004h, default=0200h

15	14	13	12	11	10	9	8	7	6	5	4	3	2	1	0
BootBufSize															

BootBufSize: total boot buffer size in words in the memory interface
 (512 words= 2^9 , $N=9$)

7.6 Amount of Buffers Register (R): F005h, default=0201h

15	14	13	12	11	10	9	8	7	6	5	4	3	2	1	0
DataBufAmount								BootBufAmount							

DataBufAmount: the amount of data buffer= $2(2^N)$, $N=1$
BootBufAmount: the amount of boot buffer= $1(2^N)$, $N=0$

7.7 Technology Register (R): F006h, default=0000h

15	14	13	12	11	10	9	8	7	6	5	4	3	2	1	0
Tech															

Tech: technology information, what technology is used for the memory

Tech	Technology
0000h	NAND SLC
0001h	NAND MLC
0002h-FFFFh	Reserved

7.8 Start Address1 Register (R/W): F100h, default=0000h

15	14	13	12	11	10	9	8	7	6	5	4	3	2	1	0
Reserved(00000000)								FBA							

FBA (NAND Flash Block Address): NAND Flash block address which will be read or programmed or erased.

Device	Number of Block	FBA
128Mb	256	FBA[7:0]

7.9 Start Address2 Register (R/W): F101h, default=0000h

15	14	13	12	11	10	9	8	7	6	5	4	3	2	1	0
Reserved(0000000000000000)															

7.10 Start Address3 Register (R/W): F102h, default=0000h

15	14	13	12	11	10	9	8	7	6	5	4	3	2	1	0
Reserved(00000000)								FCBA							

FCBA (NAND Flash Copy Back Block Address): NAND Flash destination block address which will be copy back programmed.

Device	Number of Block	FBA
128Mb	256	FBA[7:0]

7.11 Start Address4 Register (R/W): F103h, default=0000h

15	14	13	12	11	10	9	8	7	6	5	4	3	2	1	0
Reserved(00000000)								FCPA					Reserved	FCSA	

FCPA (NAND Flash Copy Back Page Address): NAND Flash destination page address in a block for copy back program operation.

FCPA(default value) = 000000

FCPA range : 000000~111111, 6bits for 64 pages

FCSA (NAND Flash Copy Back Sector Address): NAND Flash destination sector address in a page for copy back program operation.

FCSA(default value) = 0

FCSA range : 0~1, 1bits for 2 sectors

7.12 Start Address5 Register: F104h

: N/A

7.13 Start Address6 Register: F105h

: N/A

7.14 Start Address7 Register: F106h

: N/A

7.15 Start Address8 Register (R/W): F107h, default=0000h

15	14	13	12	11	10	9	8	7	6	5	4	3	2	1	0
Reserved (00000000)								FPA						Reserved	FSA

FPA (NAND Flash Page Address): NAND Flash start page address in a block for page read or copy back program or program operation.

FPA(default value)=000000

FPA range: 000000~111111 , 6bits for 64 pages

FSA (Flash Sector Address): NAND Flash start sector address in a page for read or copy back program or program operation.

FSA(default value) = 0

FSA range : 0~1, 1bits for 2 sectors

7.16 Start Buffer Register (R/W): F200h, default=0000h

15	14	13	12	11	10	9	8	7	6	5	4	3	2	1	0
Reserved(0000)				BSA				Reserved(0000000)							BSC

BSC (BufferRAM Sector Count): this field specifies the number of sectors to be read or programmed or copy back programmed.

Its maximum count is 2 sectors at 0(default value)value.

For a single sector access, it should be programmed as value 1 and it should be programmed as value 0 for two sectors.

However internal RAM buffer reached to 1 value(max. value), it counts up to 0 value to satisfy BSC value.

for example) if BSA=1101, BSC=0, then selected BufferRAM are '1101->1100'.

if BSA = 1101, BSC = 0, then the selected BufferRAM will count up from 1101 --> 1100.

BSA (BufferRAM Sector Address): It is the place where data is placed and specifies the sector 0~1 in the internal BootRAM and DataRAM.

BSA[3] is the selection bit between **BootRAM** and **DataRAM**.

BSA[2] is the selection bit between **DataRAM0** and **DataRAM1**.

BSA[0] is the selection bit between **Sector0** and **Sector1** in the internal **BootRAM** and **DataRAM**.

While one of **BootRAM** or **DataRAM0** interfaces with memory, the other **RAM** is inaccessible.

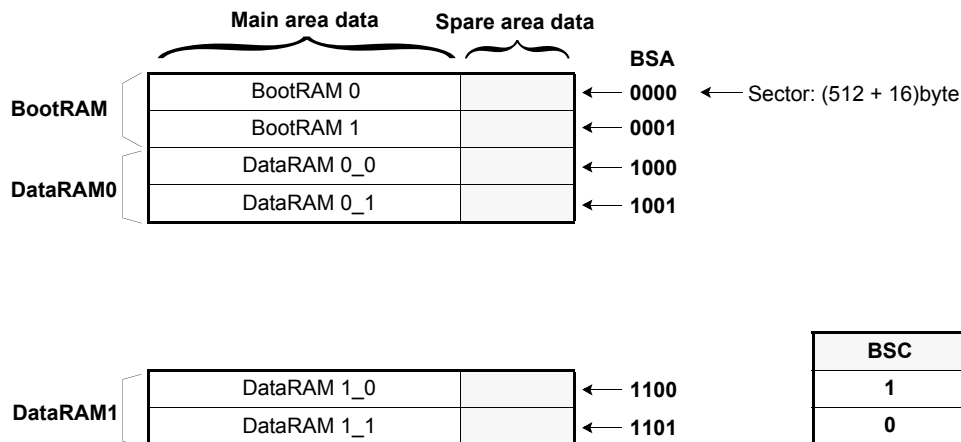

7.17 Command Register (R/W): F220h, default=0000h

15	14	13	12	11	10	9	8	7	6	5	4	3	2	1	0
Command															

Command: operation of the memory interface

CMD	Operation	Acceptable command during busy
0000h	Load single/multiple sector data unit into buffer	00F0h, 00F3h
0013h	Load single/multiple spare sector into buffer	00F0h, 00F3h
0080h	Program single/multiple sector data unit from buffer	00F0h, 00F3h
001Ah	Program single/multiple spare area sector from buffer	00F0h, 00F3h
001Bh	Copy back program	00F0h, 00F3h
0023h	Unlock NAND array block(s) from start block address to end block address	-
002Ah	Lock NAND array block(s) from start block address to end block address	-
002Ch	Lock-tight NAND array block(s) from start block address to end block address	-
0071h	Erase Verify Read	00F0h, 00F3h
0094h	Block Erase	00F0h, 00F3h
0095h	Multi-Block Erase	00F0h, 00F3h
00B0h	Erase Suspend	00F3h
0030h	Erase Resume	00F0h, 00F3h
00F0h	Reset NAND Flash Core	-
00F3h	Reset OneNAND 1)	-
0065h	OTP Access	00F0h, 00F3h

NOTE:

1)'Reset OneNAND'(=Hot reset) command makes the registers(except RDYpol, INTpol, IOBE, and OTPL bits) and NAND Flash core into default state as the warm reset(=reset by RP pin).

This R/W register describes the operation of the OneNAND interface.

Note that all commands should be issued right after INT is turned from ready state to busy state. (i.e. right after 0 is written to INT register.) After any command is issued and the corresponding operation is completed, INT goes back to ready state. (00F0h and 00F3h may be accepted during busy state of some operations. Refer to the rightmost column of the command register table above.)

7.18 System Configuration 1 Register (R, R/W): F221h, default=40C0h

15	14	13	12	11	10	9	8	7	6	5	4	3	2	1	0
R/W	R/W		R/W			R/W	R/W	R/W	R/W	R				R	
RM	BRL		BL			ECC	RDY pol	INT pol	IOBE	Reserved(0000)				BWPS	

RM (Read Mode): this field specifies the selection between asynchronous read mode and synchronous read mode

RM	Read Mode
0	Asynchronous read(default)
1	Synchronous read

BRL (Burst Read Latency): this field specifies the initial access latency in the burst read transfer.

BRL	Latency Cycles
000	8(N/A)
001	9(N/A)
010	10(N/A)
011	3(up to 40MHz)
100	4(default, min.)
101	5
110	6
111	7

BL (Burst Length): this field specifies the size of burst length during Sync. burst read. Wrap around and linear burst.

BL	Burst Length(Main)	Burst Length(Spare)
000	Continuous(default)	
001	4 words	
010	8 words	
011	16 words	
100	32 words	N/A
101~111	Reserved	

ECC: Error Correction Operation,
0=with correction(default), 1=without correction(by-passed)

RDYpol: RDY signal polarity
0=low for ready, 1=high for ready((default)

INTpol: INT Pin polarity
0=low for Interrupt pending , 1=high for Interrupt pending (default)

INTpol	INT bit of Interrupt Status Register	INT Pin output
0	0	1
1	0	0

IOBE: I/O buffer enable for INT and RDY signals, INT and RDY outputs are HighZ at power-up, bit 7 and 6 become valid after IOBE is set to 1. IOBE can be reset only by Cold reset or by writing 0 to bit 5 of System Configuration 1 register.
0=disable(default), 1=enable

BWPS: boot buffer write protect status,
0=locked(fixed)

7.19 System Configuration 2 Register : F222h

: N/A

7.22 Controller Status Register (R): F240h, default=0000h

15	14	13	12	11	10	9	8	7	6	5	4	3	2	1	0
OnGo	Lock	Load	Prog	Erase	Error	Sus	PRp	RSTB	OTPL	Reserved(000000)					TO (0)

OnGo: this bit shows the overall internal status of OneNAND
0=ready, 1=busy

Lock: this bit shows whether host loads data from NAND Flash array into locked BootRAM or programs/erases locked block of NAND Flash array.

Lock	Locked/Unlocked Check Result
0	Unlocked
1	Locked

Error (Current Sector/Page Write Result): this bit shows current sector/page Load/Program/Copy Back Program/Erase result of flash memory or whether host puts invalid command into the device.

Error	Current Sector/Page Load/Program/CopyBack. Program/Erase Result and Invalid Command Input
0	Pass
1	Fail

Sus (Erase Suspend/Resume):this bit shows the Erase Suspend Status.

Sus	Erase Suspend Status
0	Erase Resume(Default)
1	Erase Suspend

OTPL (OTP Lock Status):this bit shows OTP block is locked or unlocked. OTPL bit is automatically updated at power-on.

OTPL	OTP Locked/Unlocked Status
0	OTP Block Unlock Status(Default)
1	OTP Block Lock Status(Disable OTP Program/Erase)

TO (Time Out): time out for read/program/copy back program/erase
0=no time out(fixed)

Load : this bit shows the Load operation status
0=ready(default), 1=busy or error case, refer to the table 3

Prog (Program Busy) : this bit shows the Program operation status
0=ready(default), 1=busy or error case, refer to the table 3

Erase (Erase Busy) : this bit shows the Erase operation status
0=ready(default), 1=busy or error case, refer to the table 3

RSTB (Reset Busy) : this bit shows the Reset operation status
0=ready(default), 1=busy or error case, refer to the table 3

Table 3. Controller Status Register output for modes.

Mode	Controller Status Register [15:0]											
	OnGo	Lock	Load	Prog	Erase	Error	Sus	Reserved(0)	RSTB	OTPL	Reserved(0)	TO
Load Ongoing	1	0	1	0	0	0	0	0	0	0/1	00000	0
Program Ongoing	1	0	0	1	0	0	0	0	0	0/1	00000	0
Erase Ongoing	1	0	0	0	1	0	0	0	0	0/1	00000	0
Reset Ongoing	1	0	0	0	0	0	0	0	1	0/1	00000	0
Multi-Block Erase Ongoing	1	0	0	0	1	0	0	0	0	0/1	00000	0
Erase Verify Read Ongoing	1	0	0	0	0	0	0	0	0	0/1	00000	0
Load OK	0	0	0	0	0	0	0	0	0	0/1	00000	0
Program OK	0	0	0	0	0	0	0	0	0	0/1	00000	0
Erase OK	0	0	0	0	0	0	0	0	0	0/1	00000	0
Erase Verify Read OK ³⁾	0	0	0	0	0	0	0	0	0	0/1	00000	0
Load Fail ¹⁾	0	0	1	0	0	1	0	0	0	0/1	00000	0
Program Fail	0	0	0	1	0	1	0	0	0	0/1	00000	0
Erase Fail	0	0	0	0	1	1	0	0	0	0/1	00000	0
Erase Verify Read Fail ³⁾	0	0	0	0	1	1	0	0	0	0/1	00000	0
Load Reset ²⁾	0	0	1	0	0	1	0	0	1	0/1	00000	0
Program Reset	0	0	0	1	0	1	0	0	1	0/1	00000	0
Erase Reset	0	0	0	0	1	1	0	0	1	0/1	00000	0
Erase Suspend	0	0	0	0	1	0	1	0	0	0/1	00000	0
Program Lock	0	1	0	1	0	1	0	0	0	0/1	00000	0
Erase Lock	0	1	0	0	1	1	0	0	0	0/1	00000	0
Load Lock(Buffer Lock)	0	1	1	0	0	1	0	0	0	0/1	00000	0
OTP Program Fail(Lock)	0	1	0	1	0	1	0	0	0	1	00000	0
OTP Program Fail	0	0	0	1	0	1	0	0	0	0	00000	0
OTP Erase Fail	0	1	0	0	1	1	0	0	0	0/1	00000	0
Program Ongoing(Susp.)	1	0	0	1	1	0	1	0	0	0/1	00000	0
Load Ongoing(Susp.)	1	0	1	0	1	0	1	0	0	0/1	00000	0
Program Fail(Susp.)	0	0	0	1	1	1	1	0	0	0/1	00000	0
Load Fail(Susp.)	0	0	1	0	1	1	1	0	0	0/1	00000	0
Invalid Command	0	0	0	0	0	1	0	0	0	0/1	00000	0
Invalid Command(Susp.)	0	0	0	0	1	1	1	0	0	0/1	00000	0

NOTE:

1. ERm and/or ERs bits in ECC status register at Load Fail case is 10. (2bits error - uncorrectable)
2. ERm and ERs bits in ECC status register at Load Reset case are 00. (No error)
3. Multi Block Erase status should be checked by Erase Verify Read operation.
4. OTP Erase does not update the register and the previous value is kept.

7.23 Interrupt Status Register (R/W): F241h, default=8080h(after Cold reset),8010h(after Warm/Hot reset)

15	14	13	12	11	10	9	8	7	6	5	4	3	2	1	0	
INT	Reserved(0000000)							RI	WI	EI	RSTI	Reserved(0000)				

Bit Address	Bit Name	Default State		Valid States	Function
		Cold	Warm/Hot		
15	INT(interrupt): the master interrupt bit	1	1	0	Interrupt Off
	- Set to '1' of itself when one or more of RI, WI, EI and RSTI is set to '1', or Unlock(0023h), Lock(002Ah), Lock-tight(002Ch), or Erase Verify Read(0071h), or OTP access(0065h) operation, or "Load Data into Buffer" is completed. - Cleared to '0' when by writing '0' to this bit or by reset(Cold/Warm/Hot reset). '0' in this bit means that INT pin is low status. (This INT bit is directly wired to the INT pin on the chip. INT pin goes low upon writing '0' to this bit when INTpol is high and goes high upon writing '0' to this bit when INTpol is low.)			0->1	Interrupt Pending
7	RI(Read Interrupt):	1	0	0	Interrupt Off
	- Set to '1' of itself at the completion of Load Operation (0000h, 0013h, or boot is done.) - Cleared to '0' when by writing '0' to this bit or by reset (Cold/Warm/Hot reset).			0->1	Interrupt Pending
6	WI(Write Interrupt):	0	0	0	Interrupt Off
	- Set to '1' of itself at the completion of Program Operation (0080h, 001Ah, or 001Bh) - Cleared to '0' when by writing '0' to this bit or by reset (Cold/Warm/Hot reset).			0->1	Interrupt Pending
5	EI(Erase Interrupt):	0	0	0	Interrupt Off
	- Set to '1' of itself at the completion of Erase Operation (0094h, 0095h, or 0030h) - Cleared to '0' when by writing '0' to this bit or by reset (Cold/Warm/Hot reset).			0->1	Interrupt Pending
4	RSTI(Reset Interrupt):	0	1	0	Interrupt Off
	- Set to '1' of itself at the completion of Reset Operation (00B0h, 00F0h, 00F3h, or warm reset is released.) - Cleared to '0' when by writing '0' to this bit.			0->1	Interrupt Pending

7.24 Start Block Address (R/W): F24Ch, default=0000h

15	14	13	12	11	10	9	8	7	6	5	4	3	2	1	0
Reserved(00000000)								SBA							

SBA (Lock/Unlock/Lock-tight Start Block Address): Start NAND Flash block address in Write Protection mode, which follows 'Lock block command' or 'Unlock block command' or 'Lock-tight command'.

7.25 End Block Address (R/W): F24Dh, default=0000h

15	14	13	12	11	10	9	8	7	6	5	4	3	2	1	0
Reserved(00000000)								EBA							

EBA (Lock/Unlock/Lock-tight End Block Address): End NAND Flash block address in Write Protection mode, which follows 'Lock block command' or 'Unlock block command' or 'Lock-tight command'. EBA should be equal to or larger than SBA.

Device	Number of Block	SBA/EBA
128Mb	256	[7:0]

7.26 NAND Flash Write Protection Status (R): F24Eh, default=0002h

15	14	13	12	11	10	9	8	7	6	5	4	3	2	1	0
Reserved(00000000000000)													US	LS	LTS

US (Unlocked Status): '1' value of this bit specifies that the current block in NAND Flash is unlocked.
 LS (Locked Status): '1' value of this bit specifies that the current block in NAND Flash is in locked status.
 LTS (Lock-tighten Status): '1' value of this bit specifies that current block in NAND Flash is lock-tighten.

7.27 ECC Status Register(R): FF00h, default=0000h

15	14	13	12	11	10	9	8	7	6	5	4	3	2	1	0
Reserved(00000000)								ERm1		ERs1		ERm0		ERs0	

ERm (ECC Error for Main area data) & ERs (ECC Error for Spare area data)
 : ERm0/1 is for first/second selected sector in main of BufferRAM, ERs0/1 is for first/second selected sector in spare of BufferRAM.
 ERm and ERs show the number of error nits in a sector as a result of ECC check at the load operation.

ERm, ERs	ECC Status
00	No Error
01	1-bit error(correctable)
10	2-bit error(uncorrectable) ¹⁾
11	Reserved

NOTE:
 1. 3bits or more error detection is not supported.

7.28 ECC Result of first selected Sector Main area data Register (R): FF01h, default=0000h

15	14	13	12	11	10	9	8	7	6	5	4	3	2	1	0
Reserved(0000)				ECCposWord0								ECCposIO0			

7.29 ECC Result of first selected Sector Spare area data Register (R): FF02h, default=0000h

15	14	13	12	11	10	9	8	7	6	5	4	3	2	1	0
Reserved(0000000000)										ECClogSector0			ECCposIO0		

7.30 ECC Result of second selected Sector Main area data Register (R): FF03h, default=0000h

15	14	13	12	11	10	9	8	7	6	5	4	3	2	1	0
Reserved(0000)				ECCposWord1								ECCposIO1			

7.31 ECC Result of second selected Sector Spare area data Register (R): FF04h, default=0000h

15	14	13	12	11	10	9	8	7	6	5	4	3	2	1	0
Reserved(0000000000)										ECClogSector1			ECCposIO1		

NOTE:
 1. ECCposWord: ECC error position address that selects one of Main area data(256words)
 2. ECCposIO: ECC error position address which selects one of sixteen DQs (DQ 0~DQ 15).
 3. ECClogSector: ECC error position address that selects one of the 2nd word and LSB of the 3rd word of spare area. Refer to the below table.

ECClogSector Information [5:4]

ECClogSector	Error Position
00	2nd word
01	3rd word
10, 11	Reserved

4. ECCposWord, ECCposIO and ECClogSector are updated in boot loading operation, too.

8. Device Operation

The device supports both a limited command based and a register based interface for performing operations on the device, reading device ID, writing data to buffer etc. The command based interface is active in the boot partition, i.e. commands can only be written with a boot area address. Boot area data is only returned if no command has been issued prior to the read.

8.1 Command based operation

The entire address range, except for the boot area, can be used for the data buffer. All commands are written to the boot partition. Writes outside the boot partition are treated as normal writes to the buffers or registers. The command consists of one or more cycles depending on the command. After completion of the command the device starts its execution. Writing incorrect information which include address and data or writing an improper command will terminate the previous command sequence and make the device go to the ready status. The defined valid command sequences are stated in Table4.

Table 4. Command Sequences

Command Definition		Cycles	1st cycle	2nd cycle
Read Data from Buffer	Add	1	DP ¹⁾	
	Data		Data	
Write Data to Buffer	Add	1	DP	
	Data		Data	
Reset OneNAND	Add	1	BP ²⁾	
	Data		00F0h	
Load Data into Buffer ³⁾	Add	2	BP	BP
	Data		00E0h	0000h ⁴⁾
Read Identification Data ⁶⁾	Add	2	BP	XXXXh ⁵⁾
	Data		0090h	Data

NOTE:

- 1) DP(Data Partition) : DataRAM Area
- 2) BP(Boot Partition) : BootRAM Area [0000h ~ 01FFh, 8000h ~ 800Fh].
- 3) Load Data into Buffer operation is available within a block(64KB)
- 4) Load 1KB unit into DataRAM0. Current Start address(FPA) is automatically incremented by 1KB unit after the load.
- 5) 0000h -> Data is Manufacturer ID
0001h -> Data is Device ID
0002h -> Current Block Write Protection Status
- 6) WE toggling can terminate 'Read Identification Data' operation.

8.1.1 Read Data from Buffer

Buffer can be read by addressing a read to a wanted buffer area

8.1.2 Write Data to Buffer

Buffer can be written by addressing a write to a wanted buffer area

8.1.3 Reset OneNAND

Reset command is given by writing 00F0h to the boot partition address. Reset will return all default values into the device.

8.1.4 Load Data into Buffer

Load Data into Buffer command is a two-cycle command. Two sequential designated command activates this operation. Sequentially writing 00E0h and 0000h to the boot partition [0000h~01FFh, 8000h~800Fh] will load one page to DataRAM0. This operation refers to FBA and FPA. FSA, BSA, and BSC are not considered.

At the end of this operation, FPA will be automatically increased by 1. So continuous issue of this command will sequentially load data in next page to DataRAM0. This page address increment is restricted within a block.

The default value of FBA and FPA is 0. Therefore, initial issue of this command after power on will load the first page of memory, which is usually boot code.

8.1.5 Read Identification Data

Read Identification Data command consists of two cycles. It gives out the devices identification data according to the given address. The first cycle is 0090h to the boot partition address and second cycle is read from the addresses specified in Table5.

Table 5. Identification data description

Address	Data Out	
0000h	Manufacturer ID	00ECh
0001h	Device ID	refer to table 1
0002h	Current Block Write Protection Status	refer to NAND Flash Write Protection Status Register

8.2 Device Bus Operations

Operation	\overline{CE}	\overline{OE}	\overline{WE}	ADD0~15	DQ0~15	\overline{RP}	CLK	\overline{AVD}
Standby	H	X	X	X	High-Z	H	X	X
Warm Reset	X	X	X	X	High-Z	L	X	X
Asynchronous Write	L	H	L	Add. In	Data In	H	L	
Asynchronous Read	L	L	H	Add. In	Data Out	H	L	
Load Initial Burst Address	L	H	H	Add. In	X	H		
Burst Read	L	L	H	X	Burst Data Out	H		X
Terminate Burst Read Cycle	H	X	H	X	High-Z	H	X	X
Terminate Burst Read Cycle via \overline{RP}	X	X	X	X	High-Z	L	X	X
Terminate Current Burst Read Cycle and Start New Burst Read Cycle		H	H	Add In	High-Z	H		

Note : L=V_{IL} (Low), H=V_{IH} (High), X=Don't Care.

8.3 Reset Mode

Cold Reset

At system power-up, the voltage detector in the device detects the rising edge of Vcc and releases internal power-up reset signal which triggers bootcode loading. Bootcode loading means that the boot loader in the device copies designated sized data(1KB) from the beginning of memory to the BootRAM.

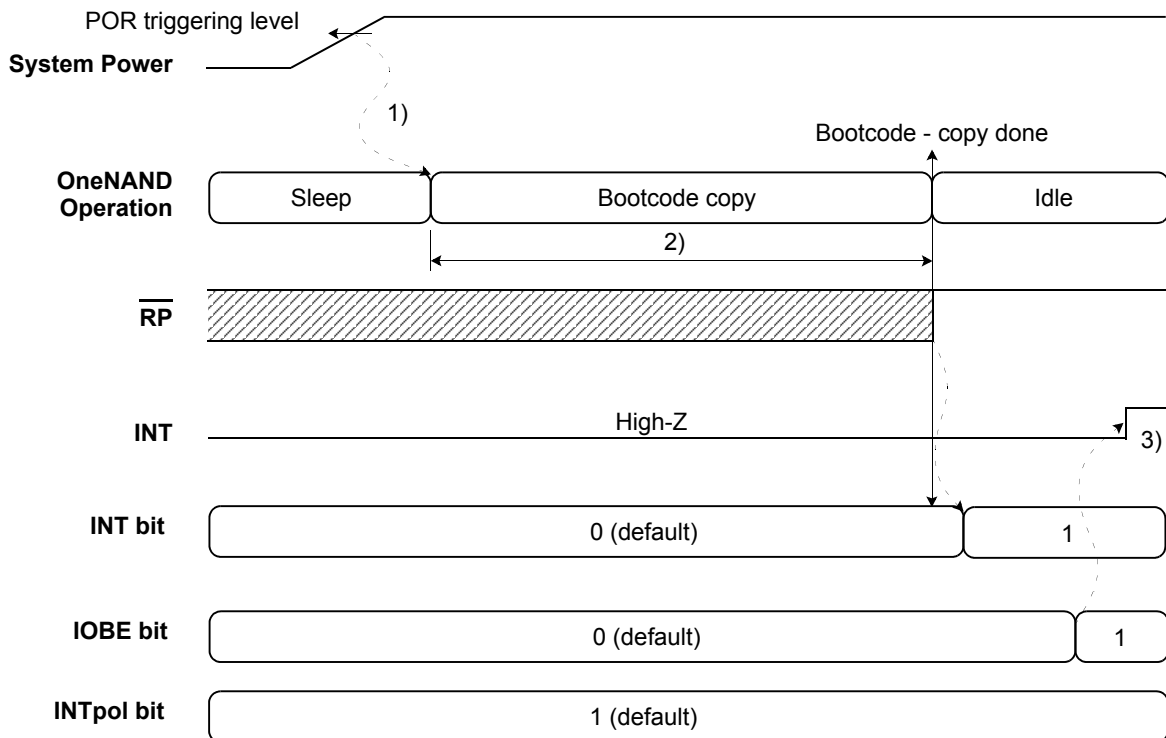

- Note: 1) Bootcode copy operation starts 400us later than POR activation.
 The system power should reach 1.7V after POR triggering level(typ. 1.5V) within 400us for valid boot code data.
 2) 1K bytes Bootcode copy takes 70us(estimated) from sector0 and sector1/page0/block0 of NAND Flash array to BootRAM.
 Host can read Bootcode in BootRAM(1K bytes) after Bootcode copy completion.
 3) INT register goes 'Low' to 'High' on the condition of 'Bootcode-copy done' and \overline{RP} rising edge.
 If RP goes 'Low' to 'High' before 'Bootcode-copy done', INT register goes to 'Low' to 'High' as soon as 'Bootcode-copy done'

Figure 5. Cold Reset Timings

Warm Reset

Warm reset means that the host resets the device by \overline{RP} pin, and then the device stops all logic current operation and executes internal reset operation(Note 1) synchronized with the falling edge of \overline{RP} and resets current NAND Flash core operation synchronized with the rising edge of \overline{RP} . The device logic will not be reset in case \overline{RP} pulses shorter than 200ns, but the device guarantees the logic reset operation in case \overline{RP} pulse is longer than 200ns. NAND Flash core reset will abort current NAND Flash Core operation. The contents of memory cells being altered are no longer valid as the data will be partially programmed or erased. Warm reset has no effect on contents of BootRAM and DataRAM.

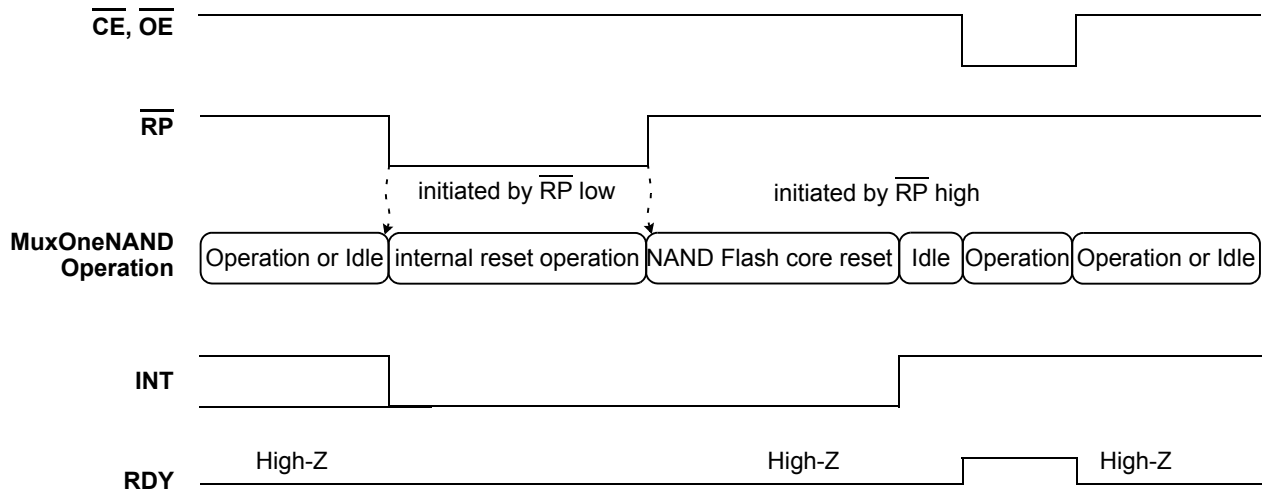

Figure 6. Warm Reset Timings

Hot Reset

Hot reset means that the host resets the device by reset command(Note 2), and then the device logic stops all current operation and executes internal reset operation(Note 1) , and resets current NAND Flash core operation. Hot reset has no effect on contents of BootRAM and DataRAM.

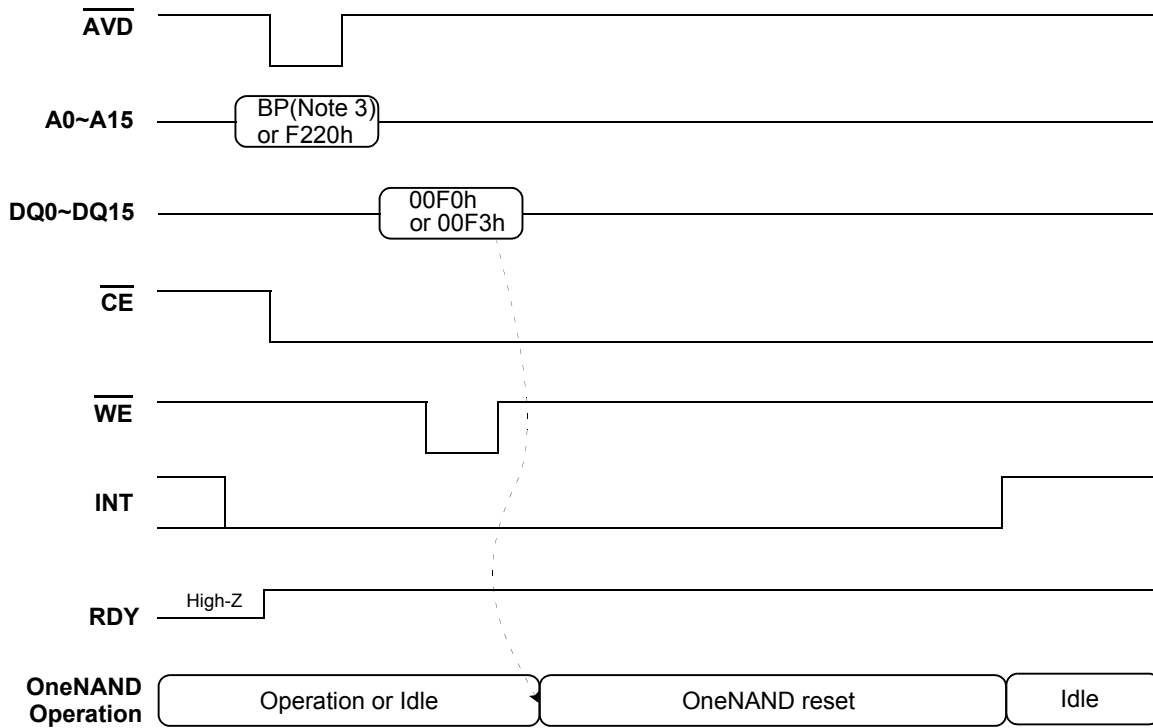

Figure 7. Hot Reset Timings

NOTE:

1. Internal reset operation means that the device initializes internal registers and makes output signals go to default status and bufferRAM data are kept unchanged after Warm/Hot reset operations.
2. Reset command : Command based reset or Register based reset
3. BP(Boot Partition) : BootRAM area[0000h~01FFh, 8000h~800Fh]

NAND Flash Core Reset

Host can reset NAND Flash Core operation by NAND Flash Core reset command. NAND Flash Core Reset will abort the current NAND Flash core operation. During a NAND Flash Core Reset, the content of memory cells being altered is no longer valid as the data will be partially programmed or erased. NAND Flash Core Reset has an effect on neither contents of BootRAM and DataRAM nor register values.

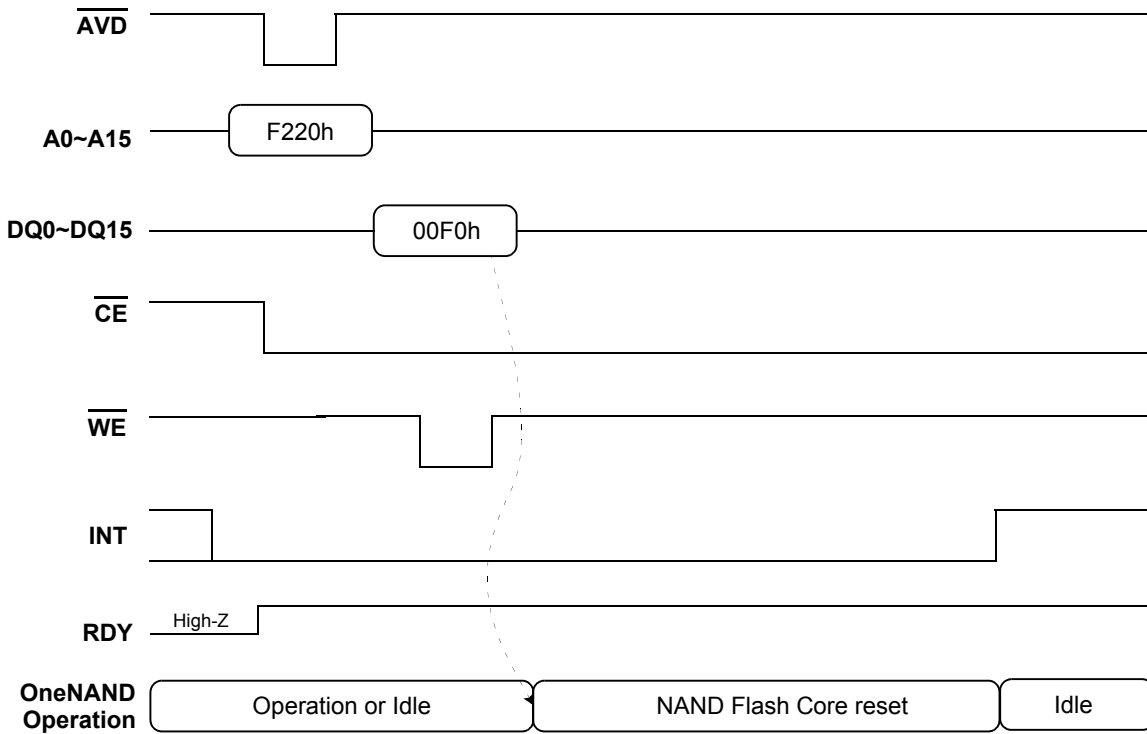

Figure 8. NAND Flash Core Reset Timings

Table 6. Internal Register reset

	Internal Registers	Default	Cold Reset	Warm Reset (RP)	Hot Reset (00F3h)	Hot Reset (BP-F0)	NAND Flash Reset(00F0h)
F000h	Manufacturer ID Register (R)	00ECh	N/A	N/A	N/A	N/A	N/A
F001h	Device ID Register (R)	Note3	N/A	N/A	N/A	N/A	N/A
F002h	Version ID Register (rR)	-	N/A	N/A	N/A	N/A	N/A
F003h	Data Buffer size Register (R)	0400h	N/A	N/A	N/A	N/A	N/A
F004h	Boot Buffer size Register (R)	0200h	N/A	N/A	N/A	N/A	N/A
F005h	Amount of Buffers Register (R)	0201h	N/A	N/A	N/A	N/A	N/A
F006h	Technology Register (R)	0000h	N/A	N/A	N/A	N/A	N/A
F100h	Start Address1 Register (R/W): FBA	0000h	0000h	0000h	0000h	0000h	N/A
F101h	Start Address2 Register (R/W): Reserved	0000h	0000h	0000h	0000h	0000h	N/A
F102h	Start Address3 Register (R/W): FCBA	0000h	0000h	0000h	0000h	0000h	N/A
F103h	Start Address4 Register (R/W): FCPA, FCSA	0000h	0000h	0000h	0000h	0000h	N/A
F107h	Start Address8 Register (R/W): FPA, FSA	0000h	0000h	0000h	0000h	0000h	N/A
F200h	Start Buffer Register (R/W): BSA, BSC	0000h	0000h	0000h	0000h	0000h	N/A
F220h	Command Register (R/W)	0000h	0000h	0000h	0000h	0000h	N/A
F221h	System Configuration 1 Register (R/W)	40C0h	40C0h	O (Note1)	O (Note1)	O (Note1)	N/A
F240h	Controller Status Register (R)	0000h	0000h	0000h	0000h	0000h	N/A
F241h	Interrupt Status Register (R/W)	-	8080h	8010h	8010h	8010h	N/A
F24Ch	Lock/Unlock Start Block Address (R/W)	0000h	0000h	0000h	N/A	N/A	N/A
F24Dh	Lock/Unlock End Block Address (R/W)	0000h	0000h	0000h	N/A	N/A	N/A
F24Eh	NAND Flash Write Protection Status (R)	0002h	0002h	0002h	N/A	N/A	N/A
FF00h	ECC Status Register (R) (Note2)	0000h	0000h	0000h	0000h	0000h	N/A
FF01h	ECC Result of Sector 0 Main area data Register(R)	0000h	0000h	0000h	0000h	0000h	N/A
FF02h	ECC Result of Sector 0 Spare area data Register (R)	0000h	0000h	0000h	0000h	0000h	N/A
FF03h	ECC Result of Sector 1 Main area data Register(R)	0000h	0000h	0000h	0000h	0000h	N/A
FF04h	ECC Result of Sector 1 Spare area data Register (R)	0000h	0000h	0000h	0000h	0000h	N/A

NOTE: 1) RDYpol, INTpol, and IOBE are reset by Cold reset. The other bits are reset by Cold/Warm/Hot reset.

OTPL is not reset but updated by Cold reset.

2) ECC Status Register & ECC Result Registers are reset when any command is issued.

3) Refer to table 1

Write Protection

Write Protection for BootRAM

At system power-up, the voltage detector in the device detects the rising edge of Vcc and releases the internal power-up reset signal which triggers bootcode loading. And the designated size data(1KB) is copied from the beginning of the memory to the BootRAM. After the bootcode loading is completed, the BootRAM is always locked to protect the significant boot code from accidental write.

Write Protection for NAND Flash array

Write Protection Modes

The device offers both hardware and software write protection features for NAND Flash array. The software write protection feature is used by writing Lock command or Lock-tight command to command register; The 002Ah or 002Ch command is written into F220h register. The partial write protection feature is also permitted by writing Partial Lock(002Ah) and Partial Lock-Tight(002Ch) command with the start address and the end address to F24Ch and F24Dh registers. The hardware write protection feature is used by executing cold or warm reset. The default state is locked, and all NAND Flash array goes to locked state after cold or warm reset.

Write Protection Commands

Individual or consecutive instant secured block protects code and data by allowing any block to be locked or lock-tighten. The write protection scheme offers two levels of protection. The first allows software-only control of write protection(useful for frequently changed data blocks), while the second requires hardware interaction before locking can be changed(protects infrequently changed code blocks).

The following summarize the locking functionality.

- > All blocks power-up in a locked state. Unlock command can unlock these blocks with the start and end block address.
- > Partial Lock-Tight command makes the part of locked block(s) to be lock-tightened by writing the start and end block address. And lock-tightened state can be returned to lock state only when cold or warm reset is asserted.
- > Only one individual area can be lock-tightened by Partial Lock-tight command; i.e lock-tightening multi area is not available.
- > Lock-tightened blocks offer the user an additional level of write protection beyond that of a regular locked block. Lock-tightened block can't have it's state changed by software, it can be changed by warm reset or cold reset.
- > Unlock start or end block address is reflected immediately to the device only when Unlock command is issued, and NAND Flash write protection status register is also updated at that time.
- > Unlocked blocks can be programmed or erased.
- > Only one area can be released from lock state to unlock state with Unlock command and addresses. This unlocked area can be changed with new Unlock command; when new Unlock command is issued, last unlocked area is locked again and new area is unlocked.
- > Partial Lock command makes the part of unlocked block(s) to be locked with the start and end block address.
- > Only one area can be locked with Partial Lock command and address. This locked area can be changed with new Partial Lock command; when new Partial Lock command is issued, last unlocked area is locked again and new area is unlocked.

Write Protection Status

The block current Write Protection status can be read in NAND Flash Write Protection Status Register(F24Eh). There are three bits - US, LS, LTS -, which are not cleared by hot reset. These Write Protection status registers are updated when Write Protection command is entered.

The followings summarize locking status.

example)

In default, [2:0] values are 010.

-> If host executes unlock block operation, then [2:0] values turn to 100.

-> If host executes lock-tight block operation, then [2:0] values turn to 001.

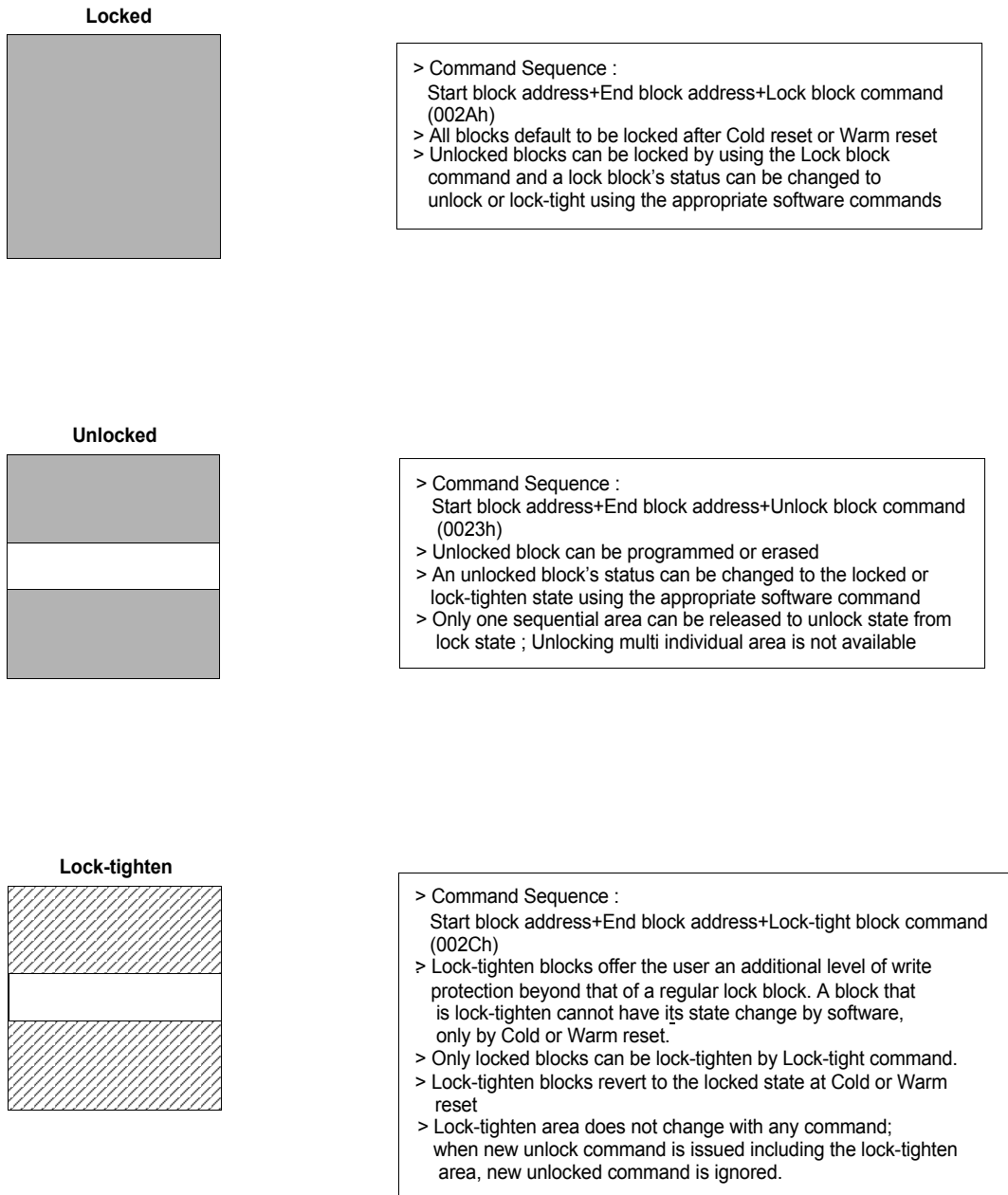

Figure 9. Operations of NAND Flash Write Protection

Load Operation

The load operation is initiated by setting up the start address from which the data is to be loaded. The load command is issued in order to initiate the load. The device transfers the data from NAND Flash array into the BufferRAM. The ECC is checked and any detected and corrected error is reported in the status response as well as any unrecoverable error. When the BufferRAM has been filled an interrupt is issued to the host in order to read the contents of the BufferRAM. The read from the BufferRAM consist of asynchronous read mode or synchronous read mode. The status information related to the BufferRAM fill operation can be checked by the host if required.

The device provides dual data buffer memory architecture. The device is capable of data-read operation from one data buffer and data-load operation to the other data buffer simultaneously. Refer to the information for more details in "Read while Load operation".

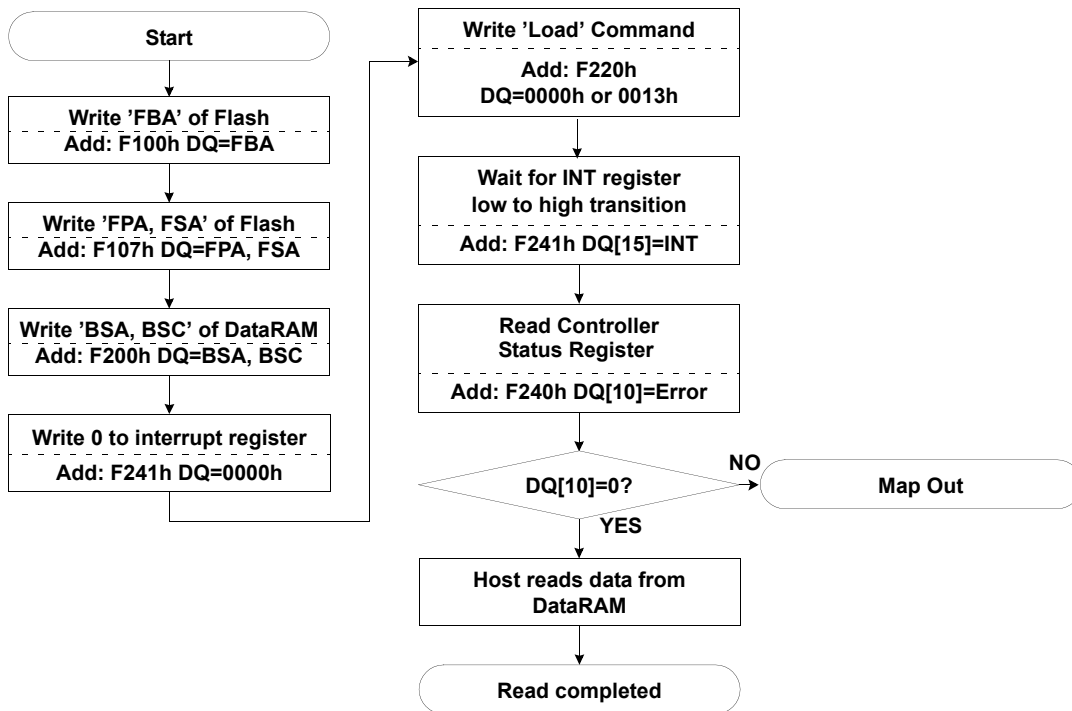

Figure 11. Load operation flow-chart

Read Operation

The device has two read configurations ; Asynchronous read and Synchronous burst read. The initial state machine makes the device to be automatically entered into asynchronous read mode to prevent the memory content from spurious altering upon device power up or after a hardware reset. No commands are required to retrieve data in asynchronous mode. The synchronous mode will be enabled by setting RM bit of System configuration1 register to Synchronous read mode.

Asynchronous Read Mode (RM = 0)

For the asynchronous read mode a valid address should be asserted on A0-A15, while driving \overline{AVD} and \overline{CE} to V_{IL} . \overline{WE} should remain at V_{IH} . The data will appear on DQ15-DQ0. Address access time (t_{AA}) is equal to the delay from valid addresses to valid output data. The chip enable access time(t_{CE}) is the delay from the falling edge of \overline{CE} to valid data at the outputs. The output enable access time(t_{OE}) is the delay from the falling edge of \overline{OE} to valid data at the output.

Synchronous (Burst) Read Mode (RM = 1)

The device is capable of continuous linear burst operation and linear burst operation of a preset length. For the burst mode, the initial word(t_{IAA}) is output asynchronously regardless of BRL bit in System Configuration 1 register. But the host should determine BRL bit of System configuration 1 register for the subsequent words of each burst access. The registers also can be read during burst read mode by using \overline{AVD} signal with a address. To initiate the synchronous read again, a new address during \overline{CE} and \overline{AVD} low toggle is needed after the host has completed status reads or the device has completed the program or erase operation.

Continuous Linear Burst Read

The initial word(t_{IAA}) is output asynchronously regardless of BRL bit in System Configuration 1 register. Subsequent words are output t_{BA} after the rising edge of each successive clock cycle, which automatically increments the internal address counter. The RDY output indicates this condition to the system by pulsing low. The device will continue to output sequential burst data, wrapping around after it reaches the designated location(See Figure 12 for address map information) until the system asserts \overline{CE} high, \overline{RP} low or \overline{AVD} low in conjunction with a new address. The cold/warm/hot reset or asserting \overline{CE} high or \overline{WE} low pulse terminate the burst read operation.

If the device is accessed synchronously while it is set to asynchronous read mode, it is possible to read out the first data without problems.

Division	Add.map(word order)	
BootM(0.5Kw)	0000h~01FFh	Buffer0
BufM 0(0.5Kw)	0200h~03FFh	
BufM 1(0.5Kw)	0400h~05FFh	Buffer1
Reserved Main	0600h~7FFFh	N/A Reg.
BootS(16w)	8000h~800Fh	Buffer0
BufS 0(16w)	8010h~801Fh	
BufS 1(16w)	8020h~802Fh	Buffer1
Reserved Spare	8030h~8FFFh	N/A Reg.
Reserved Reg.	9000h~EFFFh	
Register(4Kw)	F000h~FFFFh	Reg.

* Reserved area is not available on Synchronous read

Figure 12. The boundary of synchronous read

4-, 8-, 16-, 32- Word Linear Burst Read

As well as the Continuous Linear Burst Mode, there are four(4 & 8 & 16 & 32 word) (Note1) linear wrap-around mode, in which a fixed number of words are read from consecutive addresses. When the last word in the burst mode is reached, assert /CE and /OE high to terminate the operation. In these modes, the start address for burst read can be any address of address map.

(Note 1) 32 word linear burst read isn't available on spare area BufferRAM

Table 7. Burst Address Sequences

	Start Addr.	Burst Address Sequence(Decimal)				
		Continuous Burst	4-word Burst	8-word Burst	16-word Burst	32-word Burst
Wrap around	0	0-1-2-3-4-5-6...	0-1-2-3-0...	0-1-2-3-4-5-6-7-0...	0-1-2-3-4-...-13-14-15-0...	0-1-2-3-4-...-29-30-31-0...
	1	1-2-3-4-5-6-7...	1-2-3-0-1...	1-2-3-4-5-6-7-0-1...	1-2-3-4-5-...-14-15-0-1...	1-2-3-4-5-...-30-31-0-1...
	2	2-3-4-5-6-7-8...	2-3-0-1-2...	2-3-4-5-6-7-0-1-2...	2-3-4-5-6-...-15-0-1-2...	2-3-4-5-6-...-31-0-1-2...
	⋮	⋮	⋮	⋮	⋮	⋮

Programmable Burst Read Latency

The programmable burst read latency feature indicates to the device the number of additional clock cycles that must elapse after AVD is driven active before data will be available. Upon power up, the number of total initial access cycles defaults to four clocks. The number of total initial access cycles is programmable from three to seven cycles.

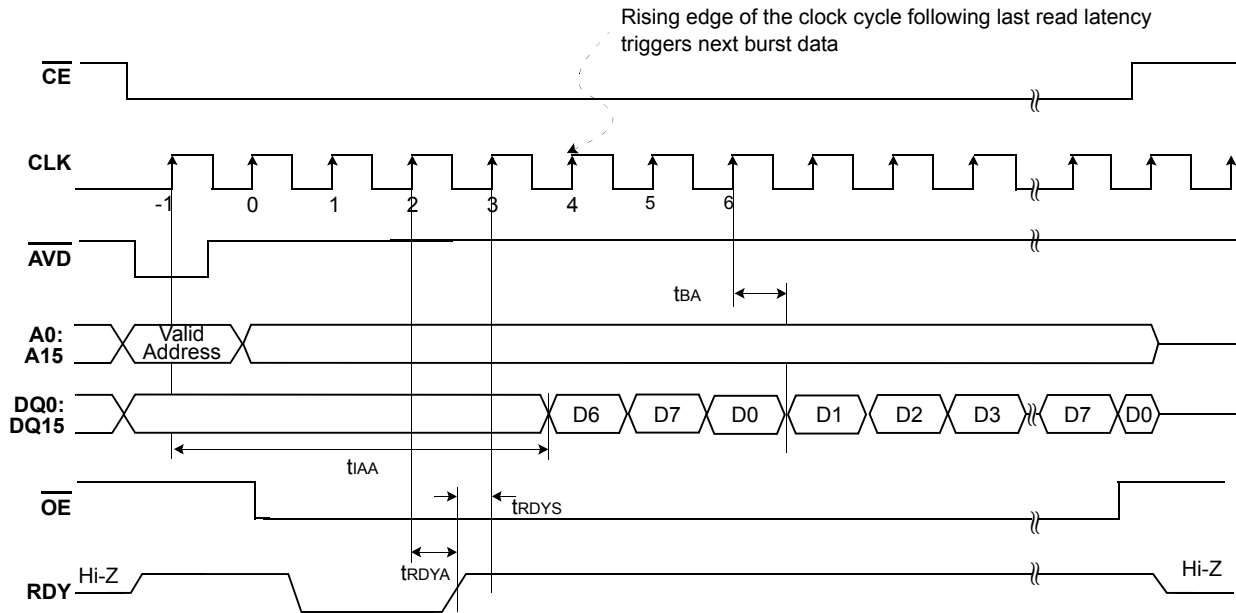

Figure 13. Example of 4 clock Burst Read Latency

Handshaking

The handshaking feature allows the host system to simply monitor the RDY signal from the device to determine when the initial word of burst data is ready to be read. To set the number of initial cycle for optimal burst mode, the host should use the programmable burst read latency configuration.(See "System Configuration1 Register" for details.) The rising edge of RDY which is derived from 1 clock ahead of data fetch clock indicates the initial word of valid burst data.

Output Disable Mode

When the CE or OE input is at VIH, output from the device is disabled. The outputs are placed in the high impedance state.

Program Operation

The device can be programmed in data unit. Programming is writing 0's into the memory array by executing the internal program routine. In order to perform the Internal Program Routine, command sequence is necessary. First, host sets the address of the BufferRAM and the memory location and loads the data to be programmed into the BufferRAM. Second, program command initiates the internal program routine. During the execution of the Routine, the host is not required to provide further controls or timings. During the Internal Program Routine, commands except reset command written to the device will be ignored. Note that a reset during a program operation will cause data corruption at the corresponding location.

The device provides dual data buffer memory architecture. The device is capable of data-write operation from host to one of data buffers during program operation from another data buffer to Flash simultaneously. Refer to the information for more details in "Read while Load operation".

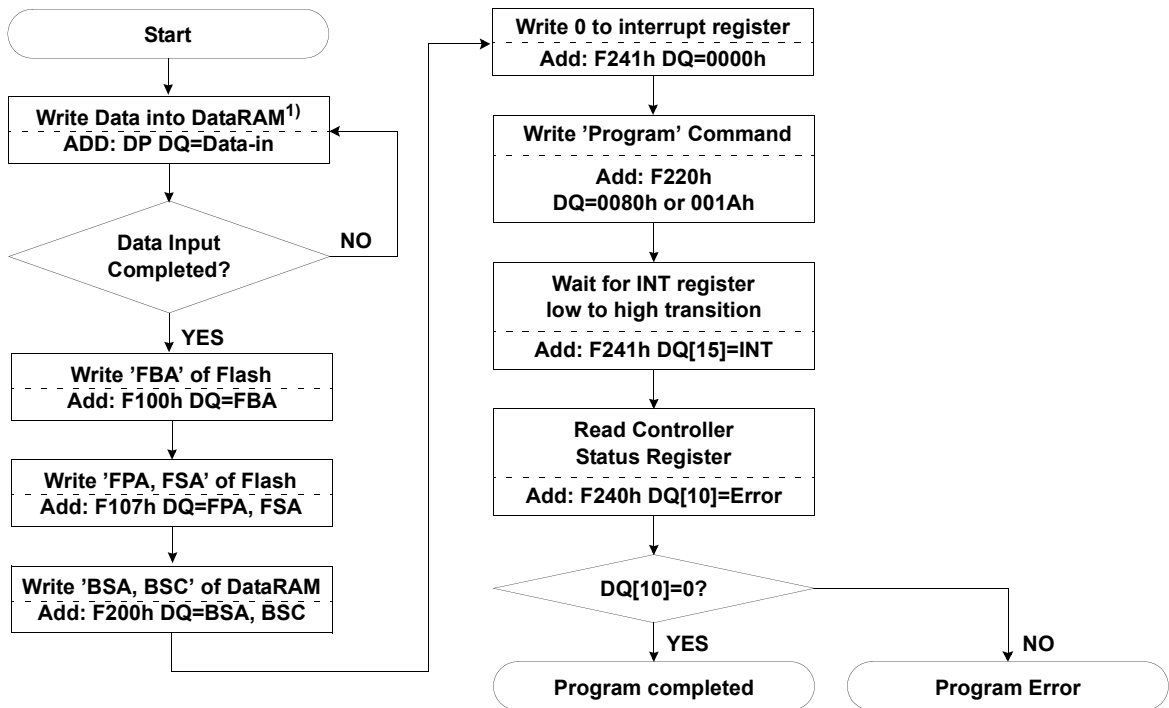

* : If program operation results in an error, map out the block including the page in error and copy the target data to another block.

Note 1) Data input could be done anywhere between "Start" and "Write Program Command".

Figure 14. Program operation flow-chart

Addressing for program operation

Within a block, the pages must be programmed consecutively from the LSB (least significant bit) page of the block to MSB (most significant bit) pages of the block. Random page address programming is prohibited.

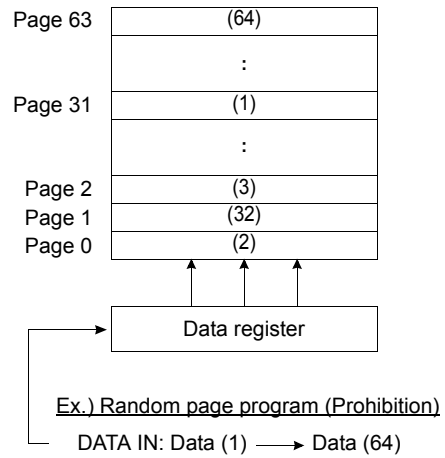
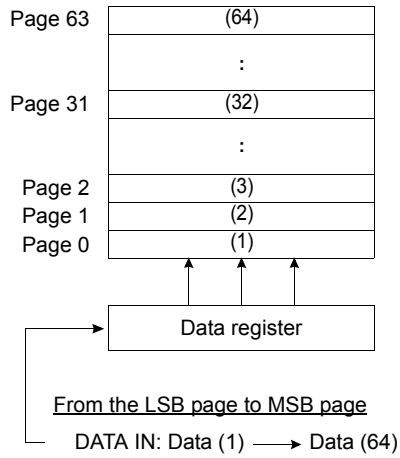

Copy-back Program Operation

The copy-back program is configured to quickly and efficiently rewrite data stored in one page by sector unit(1/2 sector) without utilizing an external memory. Since the time-consuming cycles of serial access and re-loading cycles are removed, the system performance is improved. The benefit is especially obvious when a portion of a block is updated and the rest of the block also need to be copied to the newly assigned free block. The operation for performing a copy-back program is a sequential execution of page-read without serial access and copying-program with the address of destination page.

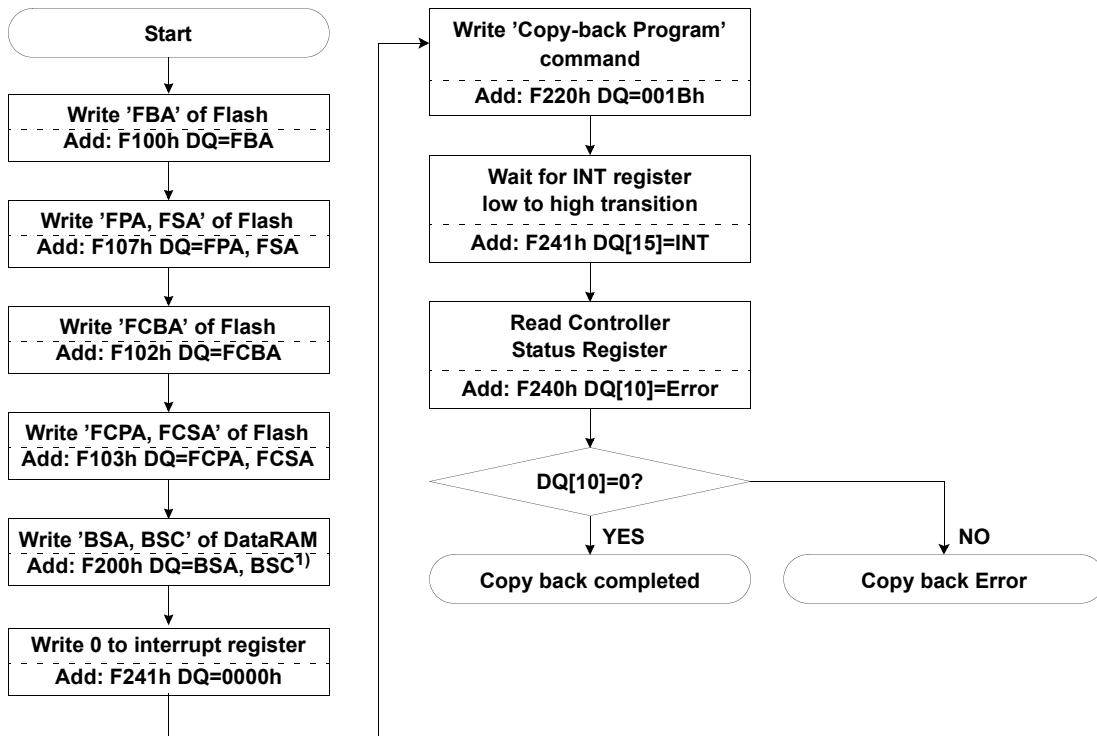

* : If program operation results in an error, map out the block including the page in error and copy the target data to another block.

Note 1) Selected DataRAM by BSA & BSC is used for Copy back operation, so previous data is overwritten.

Figure 15. Copy back program operation flow-chart

Copy-Back Program Operation with Random Data Input

The Copy-Back Program Operation with Random Data Input in OneNAND consists of 2 phase, Load data into DataRAM, Modify data and program into designated page. Data from the source page is saved in one of the on-chip DataRAM buffers and modified by the host, then programmed into the destination page.

As shown in the flow chart, data modification is possible upon completion of load operation. ECC is also available at the end of load operation. Therefore, using hardware ECC of OneNAND, accumulation of 1 bit error can be avoided.

Copy-Back Program Operation with Random Data Input will be effectively utilized at modifying certain bit, byte, word, or sector of source page to destination page while it is being copied.

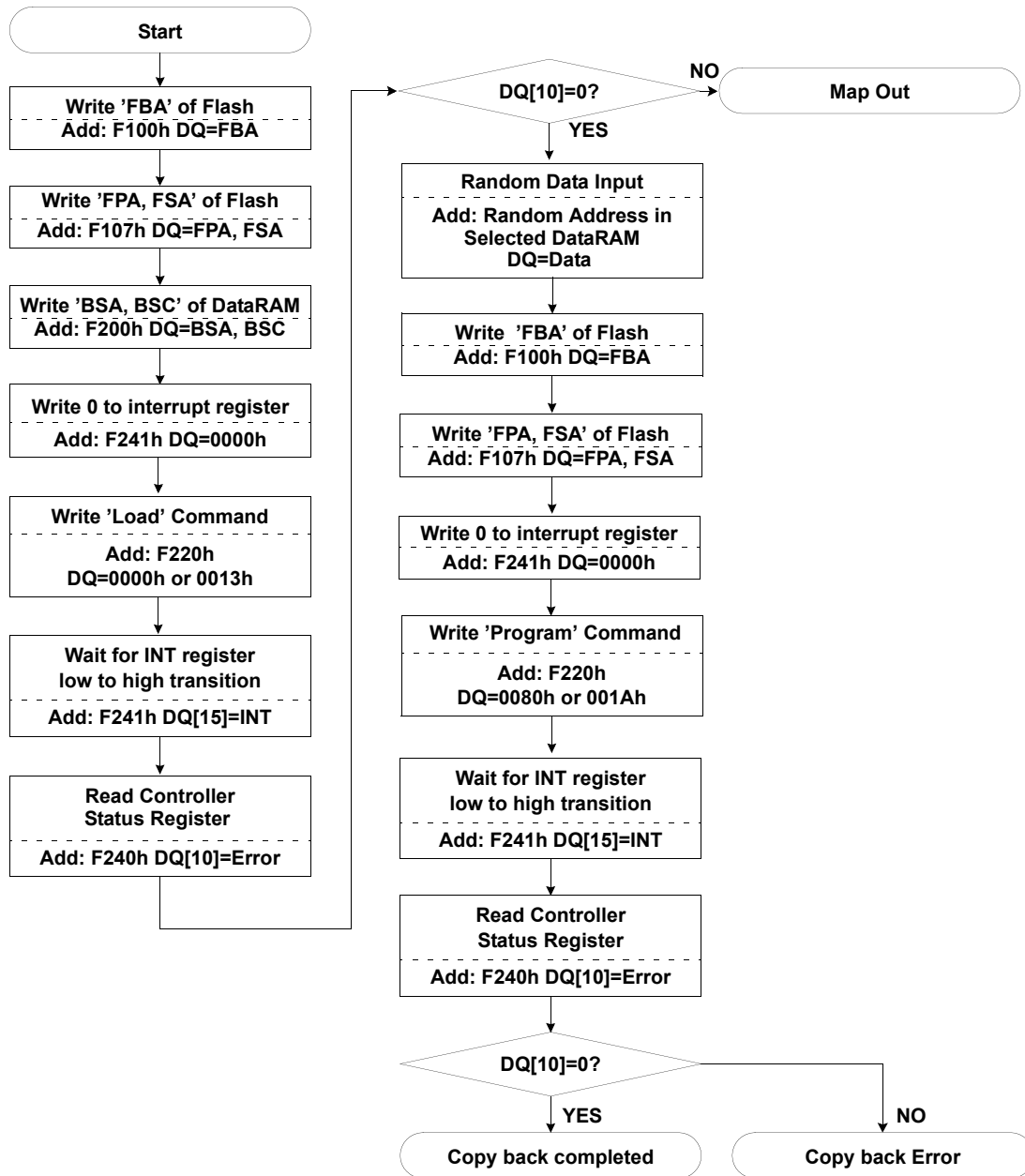

Figure 16. Copy-Back Program Operation with Random Data Input Flow Chart

Erase Operation

The device can be erased in block unit. To erase a block is to write 1's into the desired memory block by executing the Internal Erase Routine. In order to perform the Internal Erase Routine, command sequence is necessary. First, host sets the block address of the memory location. Second, erase command initiates the internal erase routine. During the execution of the Routine, the host is not required to provide further controls or timings.

During the Internal erase routine, commands except reset and erase suspend command written to the device will be ignored. Note that a reset during a erase operation will cause data corruption at the corresponding location.

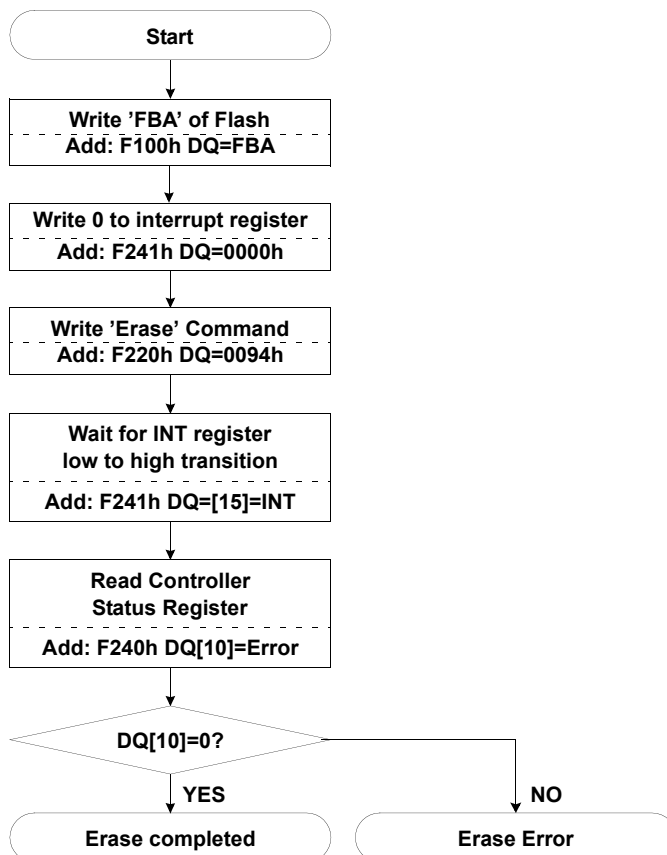

Figure 17. Erase operation flow-chart

Multi Block Erase and Multi Block Erase Verify Read Operation

The device can be simultaneously erased in multi blocks unit, too. The block address of the memory location and Multi Block Erase command may be repeated for erasing multi blocks. The final block address and Block Erase command initiate the internal multi block erase routine. During Multi Block Erase routine, if the command except Multi Block Erase command is written before Block Erase command is issued, Multi Block Erase operation will be aborted. Erase Suspend command is allowed only when INT is Low after Block Erase command is issued.

Pass/fail status of each block in Multi Block Erase operation can be read by writing each block address and Multi Block Erase Verify Read command. But the information of the failed address has to be managed by the firmware. After Block Erase operation, the pass/fail status can be read with Multi Block Erase Verify Read command, too.

Note that a reset during a erase operation will cause data corruption at the corresponding location.

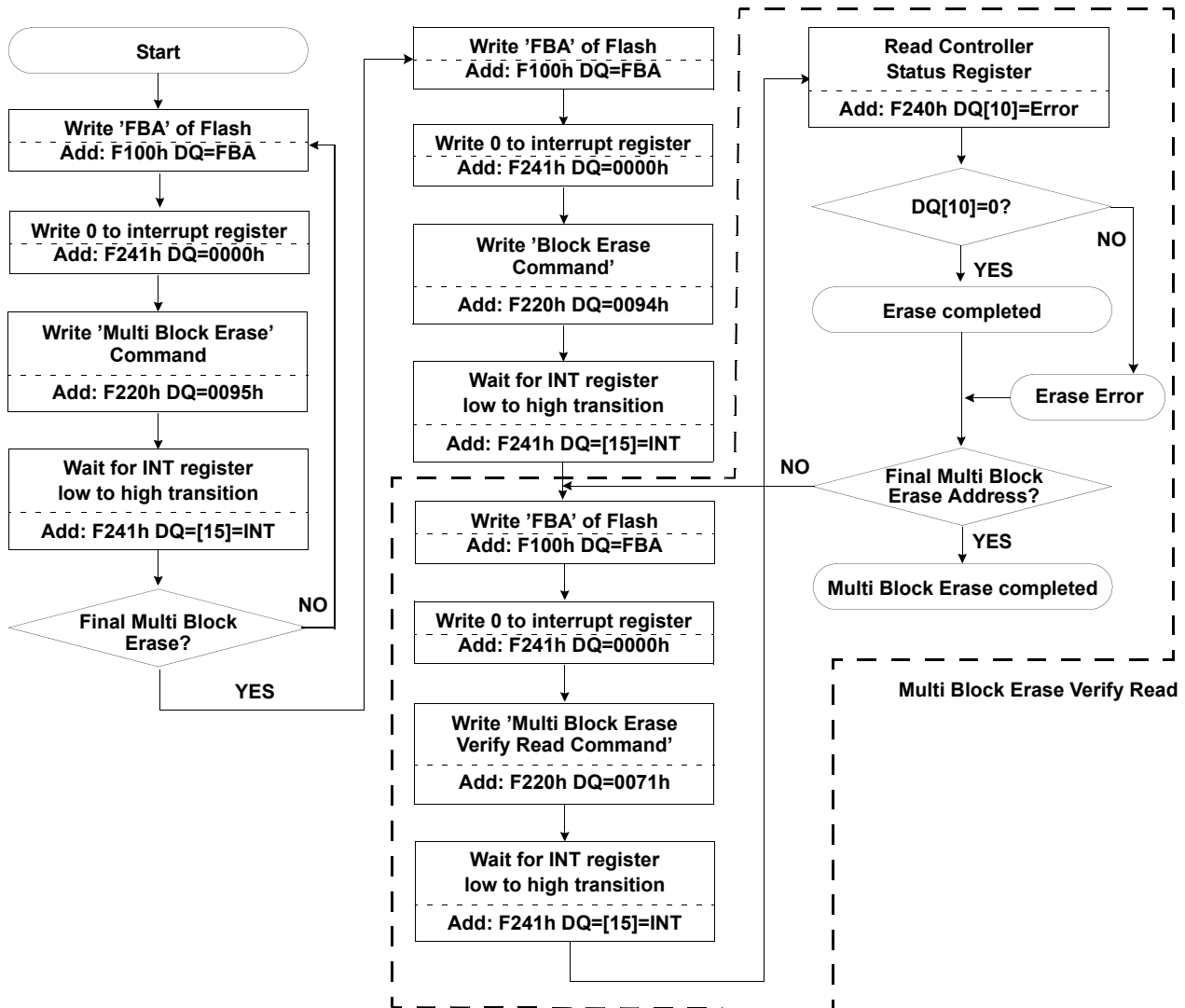

Figure 18. Multi Block Erase operation flow-chart

NOTE:

1. If there are the locked blocks in the specified range, the operation works as the follows.
 - Case 1. [BA(1)+0095h] + [BA(2, locked)+0095h] + ... + [BA(N-1)+0095h] + [BA(N)+0094h] = All specified blocks except BA(2) are erased.
 - Case 2. [BA(1)+0095h] + [BA(2)+0095h] + ... + [BA(N-1)+0095h] + [BA(N, locked)+0094h] = If the last command, Block Erase command, is put together with the locked block address, Multi Block Erase operation doesn't start and is suspended until right command and address input.
 - Case 3. [BA(1)+0095h] + [BA(2)+0095h] + ... + [BA(N-1)+0095h] + [BA(N, locked)+0094h] + [BA(N+1)+0094h] = All specified blocks except BA(N) are erased.
2. The OnGo bit of Controller Status register is set to '1'(busy) from the time of writing the 1st block address to be latched until the actual erase has finished.
3. Even though the failed blocked happen during multi block erase operation, the device continues the erase operation until other specified blocks are erased.

Erase Suspend / Resume

Erase Suspend command interrupts Block Erase and Multi Block Erase to load or program data in a block that is not being erased. When Erase Suspend command is written during Block Erase and Multi Block Erase operation, the device requires a maximum of 500us to suspend erase operation. After the erase operation has been suspended, the device is available for loading or programming data in a block that is not being erased. For the erase suspend period, Block Erase, Multi Block Erase and Erase Suspend commands are not accepted.

When Erase Resume command is executed, Block Erase and Multi Block Erase operation will resume. The Erase Resume operation does not actually resume the erase, but starts it again from the beginning. When Erase Suspend and Erase Resume command is executed, the addresses are in Don't Care state.

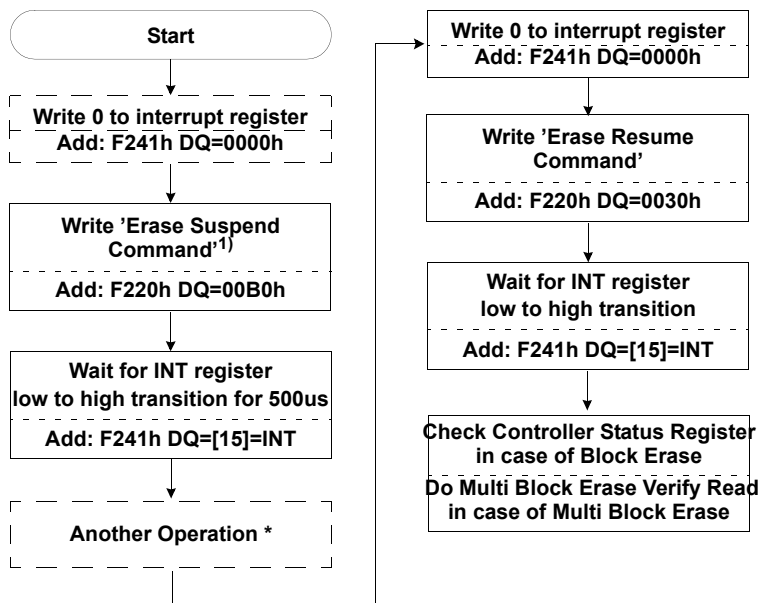

* Another Operation ; Load, Program Copy-back Program, OTP Access²⁾, Hot Reset, Flash Reset, CMD Reset, Multi Block Erase Verify, Lock, Lock-tight, Unlock

Note 1) Erase Suspend command input is prohibited during Multi Block Erase address latch period.

2) If OTP access mode exit happens with Reset operation during Erase Suspend mode, Reset operation could hurt the erase operation. So if a user wants to exit from OTP access mode without the erase operation stop, Reset NAND Flash Core command should be used.

Figure 19. Erase Suspend and Resume operation flow-chart

OTP Operation

The device supports one block sized OTP area, which can be read, programmed and locked with the same sequence as normal operation. But this OTP block could not be erased. This block is separated from NAND Flash Array, so it could be accessed by OTP Access command instead of FBA. If user wants to exit from OTP access mode, Cold, Warm and Hot Reset operation should be done. But if OTP access mode exit happens with Reset operation during Erase Suspend mode, Reset operation could hurt the erase operation. So if user wants to exit from OTP access mode without the erase operation stop, 'Reset NAND Flash Core' command should be used.

OTP area is one block size(64KB, 64pages) and is divided by two areas. The first area from page 0 to page 19, total 20pages, is assigned for user and the second area from page 20 to page 63, total 44pages, are occupied for the device manufacturer. The second area is programmed prior to shipping, so this area could not be used by user.

This block is fully guaranteed to be a valid block.

OTP Block Page Allocation Information

Area	Page	Use
User	0 ~ 19 (20 pages)	Designated as user area
Manufacturer	20 ~ 63 (44 pages)	Used by the device manufacturer

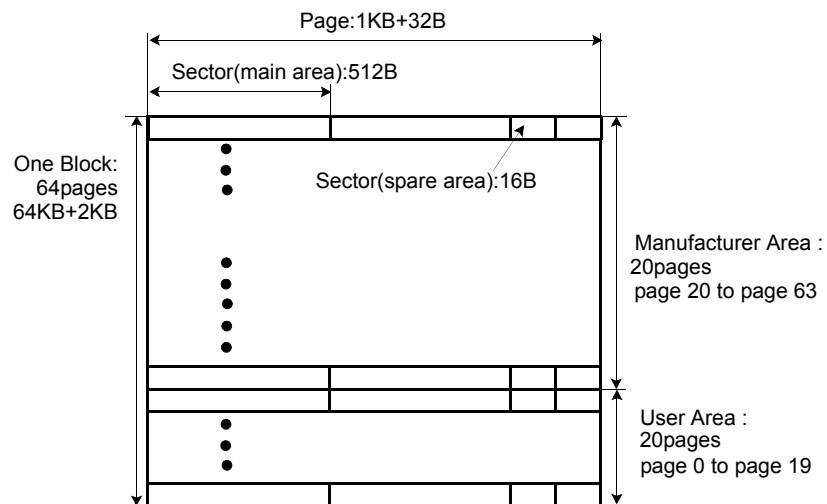
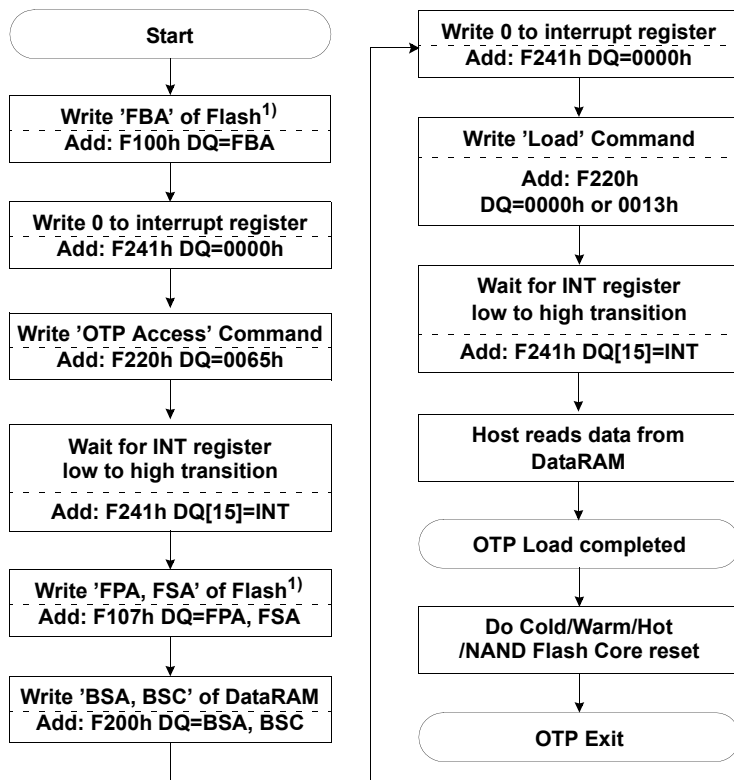

Figure 20. OTP area structure and assignment

OTP Load(OTP Access+Load NAND)

OTP area is separated from NAND Flash Array, so it is accessed by OTP Access command instead of FBA. The content of OTP could be loaded with the same sequence as normal load operation after being accessed by the command. If user wants to exit from OTP access mode, Cold, Warm, Hot, and NAND Flash Core Reset operation should be done.



Note 1) FBA(NAND Flash Block Address) could be omitted or any address.

Figure 21. OTP Load operation flow-chart

OTP Programming(OTP Access+Program NAND)

OTP area could be programmed with the same sequence as normal program operation after being accessed by the command. To avoid the accidental write, FBA should point the unlocked area address among NAND Flash Array address map even though OTP area is separated from NAND Flash Array.

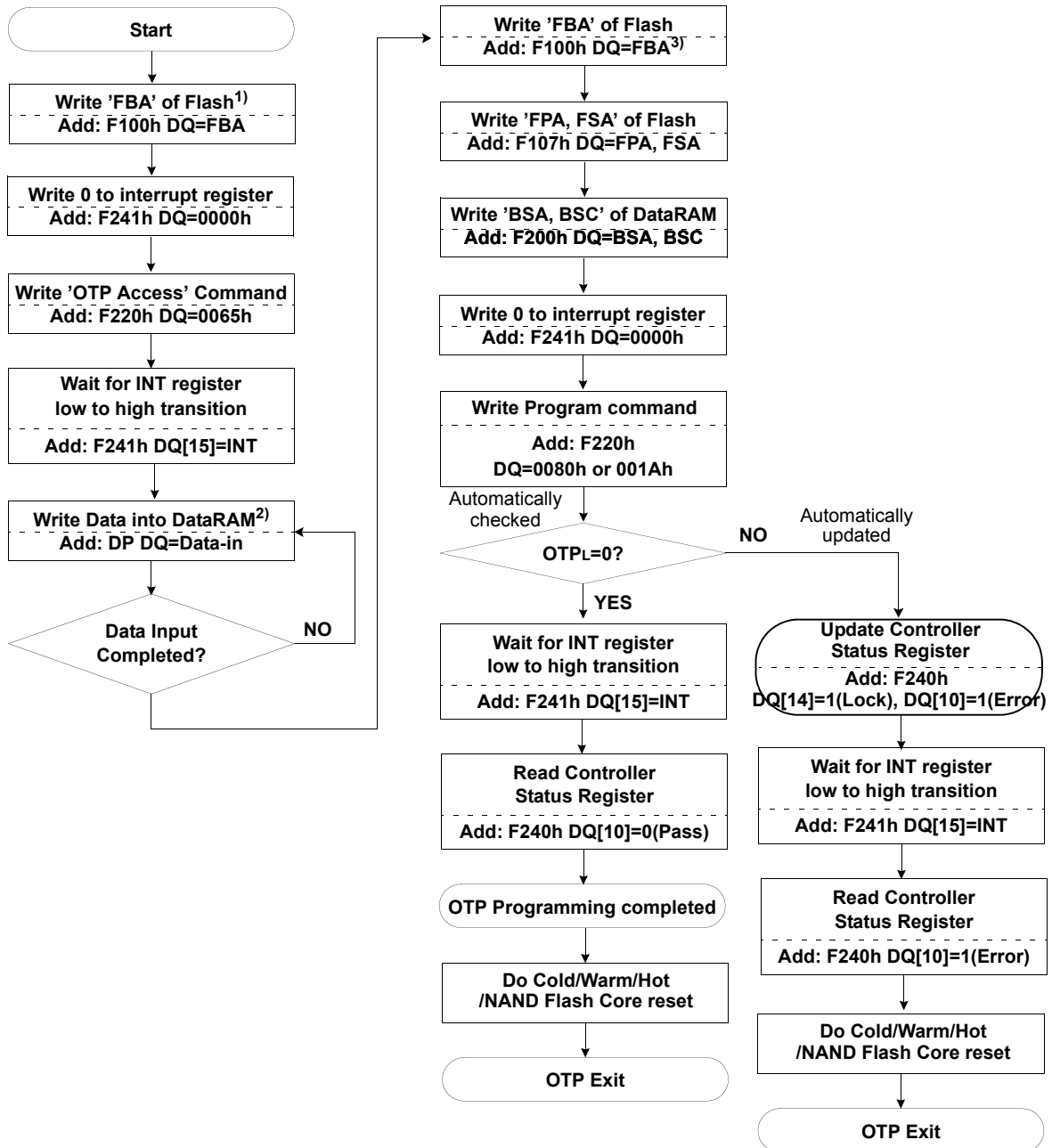

Note 1) FBA(NAND Flash Block Address) could be omitted or any address.
 2) Data input could be done anywhere between "Start" and "Write Program Command".
 3) FBA should point the unlocked area address among NAND Flash Array address map.

Figure 22. OTP program operation flow-chart

OTP Lock(OTP Access+Lock OTP)

OTP area could be locked by programming XXXCh to 8th word in sector0 of page0 to prevent the program operation. At the device power-up, the device automatically checks this word and updates OTPL bit of Controller Status register as "1"(lock). If the program operation happens in OTP locked status, the device updates Error bit of Controller Status register as "1"(fail).

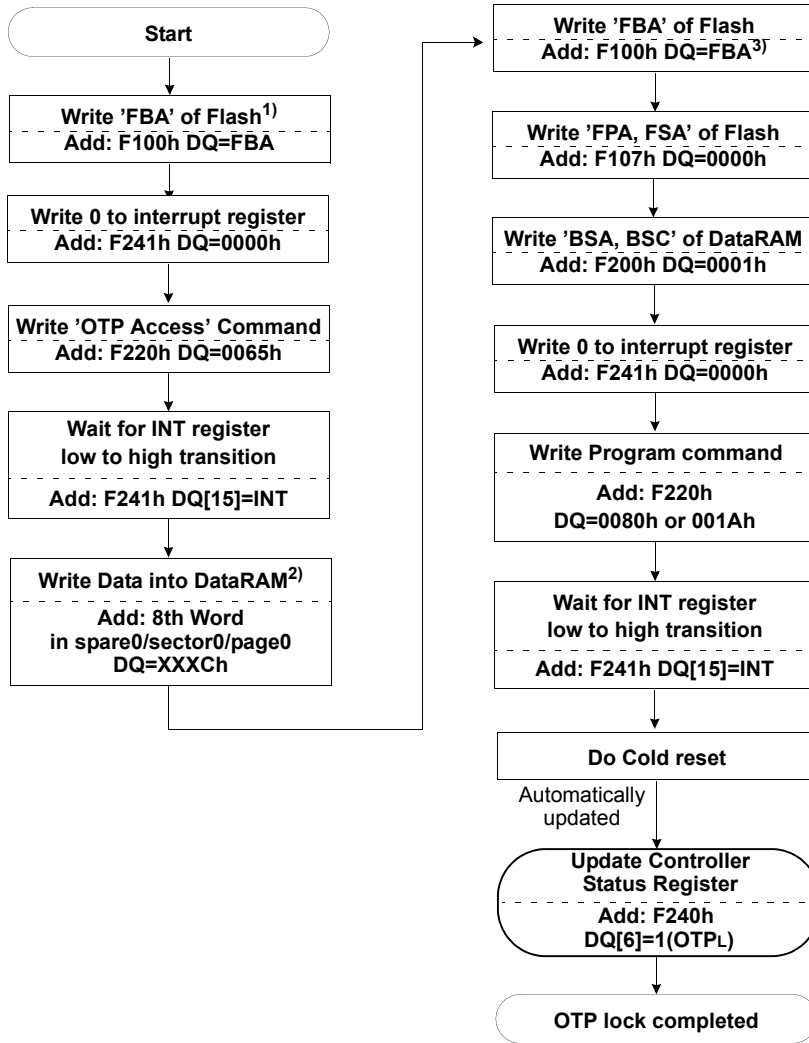

- Note 1) FBA(NAND Flash Block Address) could be omitted or any address.
- 2) Data input could be done anywhere between "Start" and "Write Program Command".
- 3) FBA should point the unlocked area address among NADND Flash Array address map.

Figure 23. OTP lock operation flow-chart

Read While Load

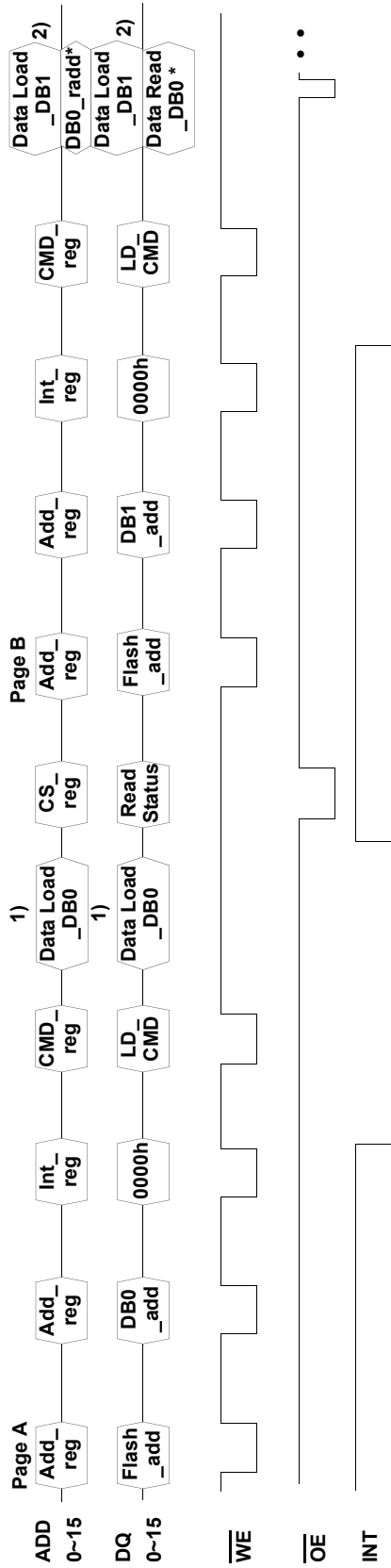

- Int_reg : Interrupt Register Address
- Add_reg : Address Register Address
- Flash_add : Flash Address to be loaded
- DBn_add : DataRAM Address to be loaded
- CMD_reg : Command Register Address
- LD_CMD : Load Command
- Data_Load_Dbn : Load Data from NAND Flash Array to DataRAMn
- CS_reg : Controller Status Register Address
- Data_Read_Dbn : Read Data from DBn
- DBn_radd : DataRAM Address to be read

The device provides dual data buffer memory architecture. The device is capable of data-read operation from one data buffer and data-load operation to another data buffer simultaneously. This is so called the Read while Load operation with dual data buffer architecture, this feature provides the capability of executing reading data from one of data buffers during data-load operation from Flash to the other buffer simultaneously. Refer to the information for more details in "Load operation" before performing read while load operation. Simultaneous load and read operation to same data buffer is prohibited.

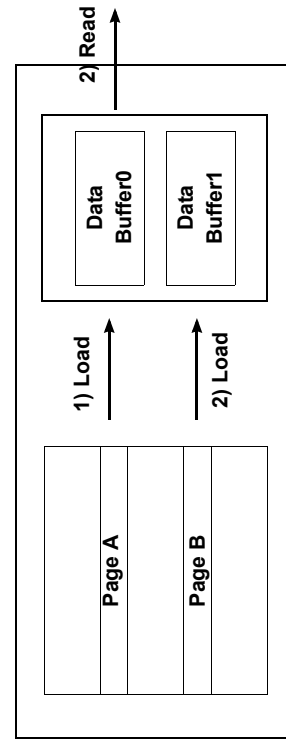

Write While Program

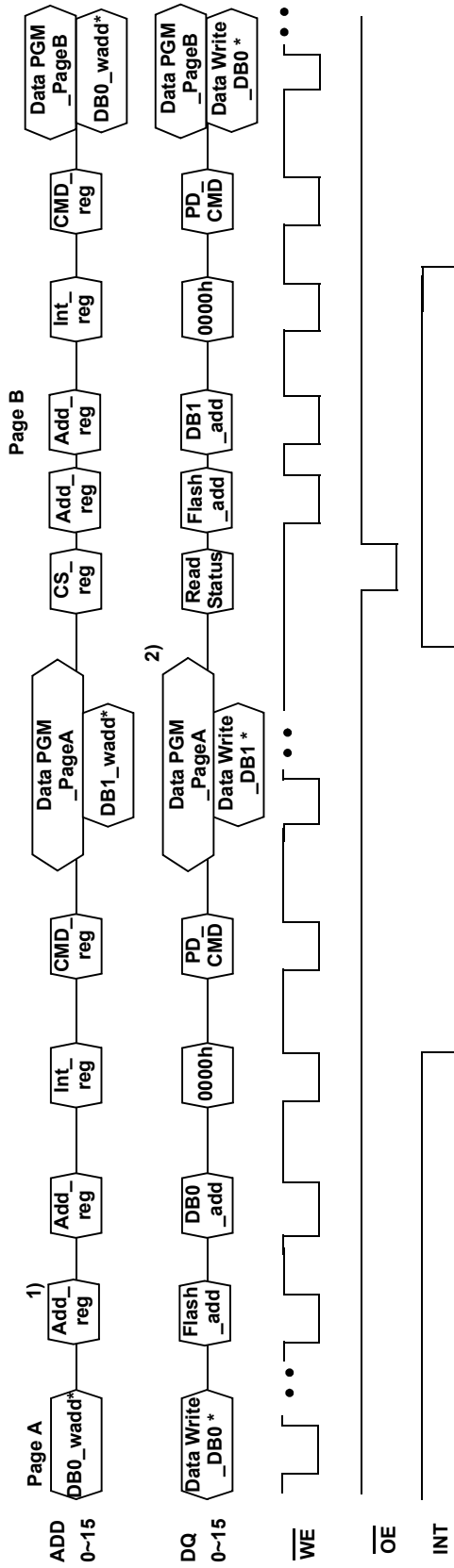

- Add_reg : Address Register Address
- DBn_add : DataRAM Address to be programmed
- DBn_wadd : DataRAM Address to be written
- Data_Write_DBn : Write Data to DataRAMn
- Flash_add : Flash Address to be programmed
- Int_reg : Interrupt Register Address
- CMD_reg : Command Register Address
- PD_CMD : Program Command
- Data_PGM_PageA : Program Data from DataRAM to PageA
- CS_reg : Controller Status Register Address

The device provides dual data buffer memory architecture. The device is capable of data-write operation and program operation simultaneously. This is so called the write while program operation with dual data buffer architecture, this feature provides the capability of executing data-write operation from host to one of data buffers during program operation from another data buffer to Flash simultaneously. Refer to the information for more details in "Program operation" before performing write while program operation. Simultaneous program and write operation to same data buffer is prohibited.

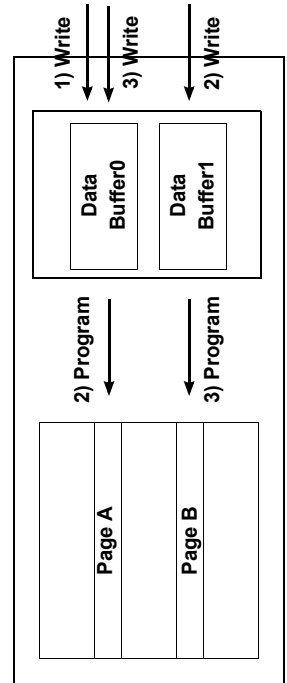

ECC Operation

While the device transfers data from BufferRAM to NAND Flash Array Page Buffer for Program Operation, the device hiddenly generates ECC(24bits for main area data and 10bits for 2nd and 3rd word data of each sector spare area) and while Load operation, hiddenly generates ECC and detects error number and position and corrects 1bit error. ECC is updated by the device automatically. After Load Operation, host can know whether there is error or not by reading 'ECC Status Register'(refer to ECC Status Register Table). In addition, OneNAND supports 2bit EDC even though it is little probable that 2bit error occurs. Hence, it is not recommended that Host reads 'ECC Status Register' for checking ECC error because the built-in Error Correction Logic of OneNAND finds out and corrects ECC error.

When the device loads NAND Flash Array main and spare area data with ECC operation, the device does not place the newly generated ECC for main and spare area into the buffer but places ECC which was generated and written in program operation into the buffer.

Ecc operation is done during the boot loading operation.

ECC Bypass Operation

ECC bypass operation is set by 9th bit of System Configuration 1 register. In ECC Bypass operation, the device neither generates ECC result which indicates error position nor updates ECC code to NAND Flash array spare area in program operation(refer to ECC Result Register Tables). During Load operation, the on-chip ECC engine does not generate a new ECC internally and the values of ECC Status and Result Registers are invalid. Hence, in ECC Bypass operation, the error cannot be detected and corrected by OneNAND itself. ECC Bypass operation is not recommended to host.

Table 8. ECC Code & Result Status by ECC operation mode

Operation	Program operation	Load operation		
	ECC Code Update to NAND Flash Array Spare Area	ECC Code at BufferRAM Spare Area	ECC Status & Result Update to Registers	1bit Error
ECC operation	Update	Pre-written ECC code ⁽¹⁾ loaded	Update	Correct
ECC bypass	Not update	Pre-written code loaded	Invalid	Not correct

NOTE:

1. Pre-written ECC code : ECC code which is previously written to NAND Flash Spare Area in program operation.

Data Protection during Power Down

The device is designed to offer protection from any involuntary program/erase during power-transitions. An internal voltage detector disables all functions whenever Vcc is below about 1.3V. RP pin provides hardware protection and is recommended to be kept at VIL before power-down.

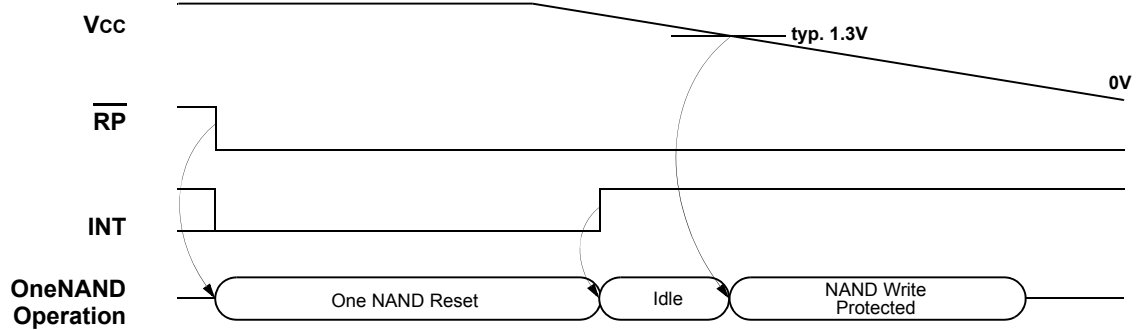

Figure 24. Data Protection during Power Down

Technical Notes

Invalid Block(s)

Invalid blocks are defined as blocks that contain one or more invalid bits whose reliability is not guaranteed by Samsung. The information regarding the invalid block(s) is so called as the invalid block information. Devices with invalid block(s) have the same quality level as devices with all valid blocks and have the same AC and DC characteristics. An invalid block(s) does not affect the performance of valid block(s) because it is isolated from the bit line and the common source line by a select transistor. The system design must be able to mask out the invalid block(s) via address mapping. The 1st block, which is placed on 00h block address, is fully guaranteed to be a valid block.

Identifying Invalid Block(s)

All device locations are erased(FFFFh) except locations where the invalid block(s) information is written prior to shipping. The invalid block(s) status is defined by the 1st word in the spare area. Samsung makes sure that either the 1st or 2nd page of every invalid block has non-FFFFh data at the 1st word of sector0. Since the invalid block information is also erasable in most cases, it is impossible to recover the information once it has been erased. Therefore, the system must be able to recognize the invalid block(s) based on the original invalid block information and create the invalid block table via the following suggested flow chart(Figure 24). Any intentional erasure of the original invalid block information is prohibited.

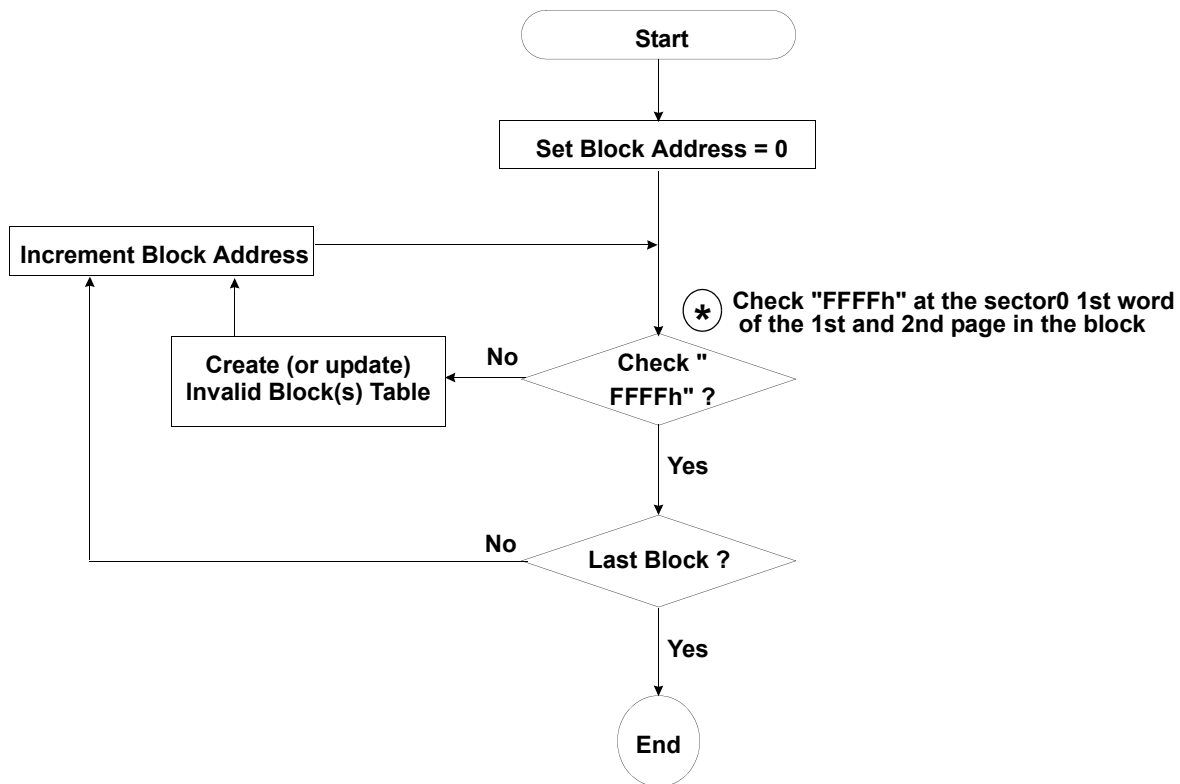

Figure 25. Flow chart to create invalid block table.

Technical Notes (Continued)

Error in write or load operation

Within its life time, additional invalid blocks may develop with the device. Refer to the qualification report for the actual data. The following possible failure modes should be considered to implement a highly reliable system. In the case of status read failure after erase or program, block replacement should be done. Because program status fail during a page program does not affect the data of the other pages in the same block, block replacement can be executed with a page-sized buffer by finding an erased empty block and reprogramming the current target data and copying the rest of the replaced block.

	Failure Mode	Detection and Countermeasure sequence
Write	Erase Failure	Status Read after Erase --> Block Replacement
	Program Failure	Status Read after Program --> Block Replacement
Load	Single Bit Failure	Error Correction by ECC mode of the device

Block Replacement

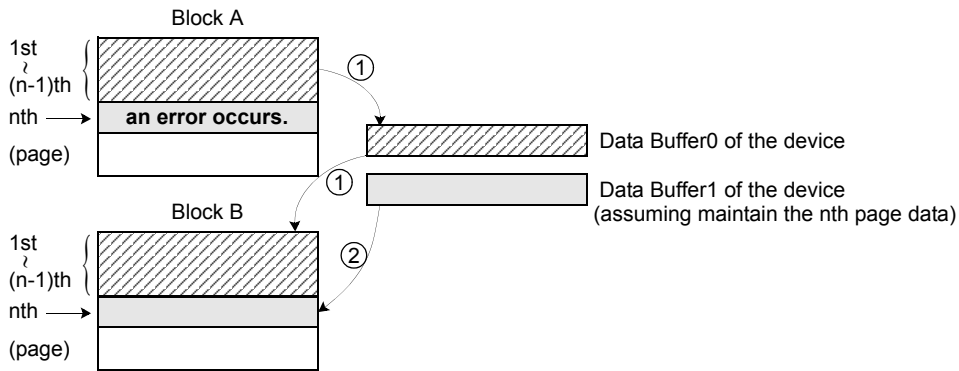

When an error happens in the nth page of the Block 'A' during program operation.

* Step1

Then, copy the data in the 1st ~ (n-1)th page to the same location of the Block 'B' via data buffer0.

* Step2

Copy the nth page data of the Block 'A' in the data buffer1 to the nth page of another free block. (Block 'B')

Do not further erase or program Block 'A' by creating an 'invalid Block' table or other appropriate scheme.

Technical Notes (Continued)**Boot Sequence**

One of the best features OneNAND has is that it can be a booting device itself since it contains an internally built-in boot loader despite the fact that its core architecture is based on NAND Flash. Thus, OneNAND does not make any additional booting device necessary for a system, which imposes extra cost or area overhead on the overall system.

As the system power is turned on, the boot code originally stored in NAND Flash Array is moved to BootRAM automatically and then fetched by CPU through the same interface as SRAM's or NOR Flash's if the size of the boot code is less than 1KB. If its size is larger than 1KB and less than or equal to 2KB, only 1KB of it can be moved to BootRAM automatically and fetched by CPU, and the rest of it can be loaded into one of the DataRAMs whose size is 1KB by Load Command and CPU can take it from the DataRAM after finishing the code-fetching job for BootRAM. If its size is larger than 2KB, the 1KB portion of it can be moved to BootRAM automatically and fetched by CPU, and its remaining part can be moved to DRAM through two DataRAMs using dual buffering and taken by CPU to reduce CPU fetch time.

A typical boot scheme usually used to boot the system with OneNAND is explained at Figure 26 and Figure 27. In this boot scheme, boot code is comprised of BL1, where BL stands for Boot Loader, BL2, and BL3. Moreover, the size of the boot code is larger than 2KB (the 3rd case above). BL1 is called primary boot loader in other words. Here is the table of detailed explanations about the function of each boot loader in this specific boot scheme.

Boot Loaders in OneNAND

Boot Loader	Description
BL1	Moves BL2 from NAND Flash Array to DRAM through two DataRAMs using dual buffering
BL2	Moves OS image (or BL3 optionally) from NAND Flash Array to DRAM through two DataRAMs using dual buffering
BL3 (Optional)	Moves or writes the image through USB interface

NAND Flash Array of OneNAND is divided into the partitions as described at Figure 26 to show where each component of code is located and how much portion of the overall NAND Flash Array each one occupies. In addition, the boot sequence is listed below and depicted at Figure 27.

Boot Sequence :

1. Power is on
BL1 is loaded into BootRAM
2. BL1 is executed in BootRAM
BL2 is loaded into DRAM through two DataRAMs using dual buffering by BL1
3. BL2 is executed in DRAM
OS image is loaded into DRAM through two DataRAMs using dual buffering by BL2
4. OS is running

Technical Notes (Continued)

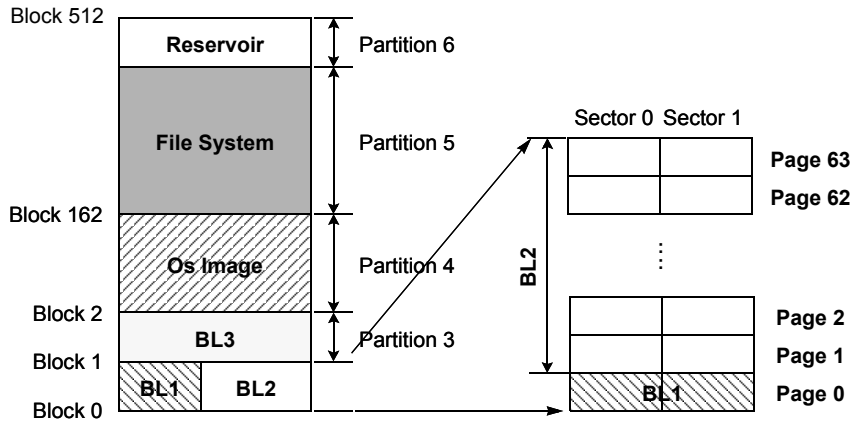
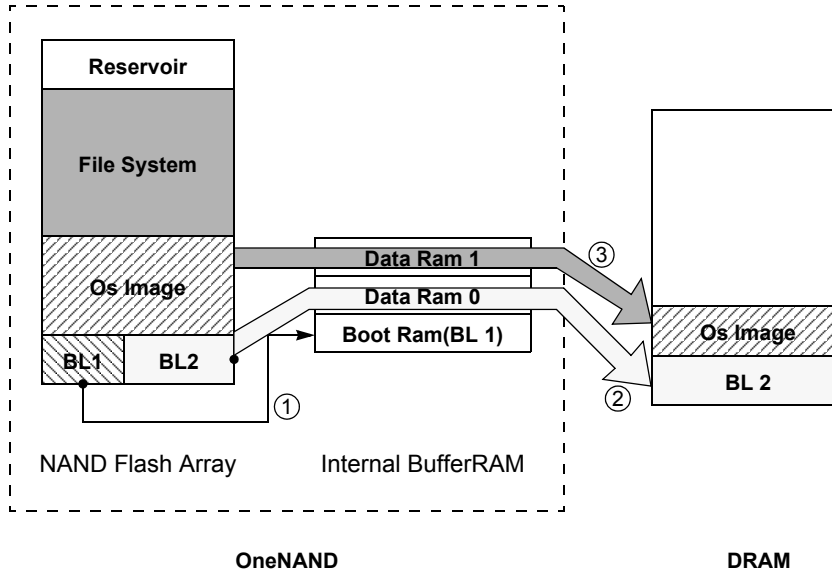

Figure 26. Partition of NAND Flash array



NOTE:
 ② and ③ can be copied into DRAM through two DataRAMs using dual buffering

Figure 27. OneNAND Boot Sequence

Technical Notes (Continued)**Methods of Determining Interrupt Status**

There are two methods of determining Interrupt Status on the OneNAND. Using the INT pin or monitoring the Interrupt Status Register Bit.

The OneNAND INT pin is an output pin function used to notify the Host when a command has been completed. This provides a hardware method of signaling the completion of a program, erase, or load operation.

In its normal state, the INT pin is high if the INT polarity bit is default. Before a command is written to the command register, the INT bit must be written to '0' so the INT pin transitions to a low state indicating start of the operation. Upon completion of the command operation by the OneNAND's internal controller, INT returns to a high state.

INT is an open drain output allowing multiple INT outputs to be Or-tied together. INT does not float to a hi-Z condition when the chip is deselected or when outputs are disabled. Refer to section 2.8 for additional information about INT.

INT can be implemented by tying INT to a host GPIO or by continuous polling of the Interrupt status register.

The INT Pin to a Host General Purpose I/O

INT can be tied to a Host GPIO to detect the rising edge of INT, signaling the end of a command operation.

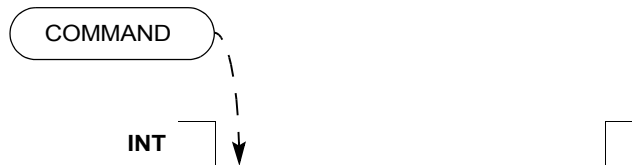

This can be configured to operate either synchronously or asynchronously as shown in the diagrams below.

Technical Notes (Continued)

Synchronous Mode Using the INT Pin

When operating synchronously, INT is tied directly to a Host GPIO. RDY could be connected as one of following guides.

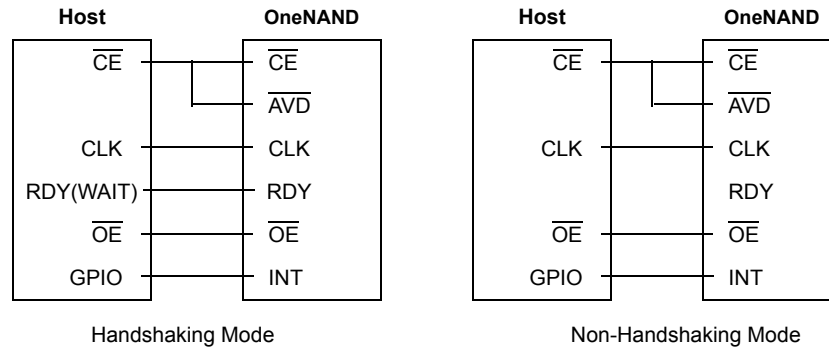

Asynchronous Mode Using the INT Pin

When configured to operate in an asynchronous mode, CE and AVD of the OneNAND are tied to CE of the Host. CLK is tied to the Host Vss (Ground). RDY is tied to a no-connect. OE of the OneNAND and Host are tied together and INT is tied to a GPIO.

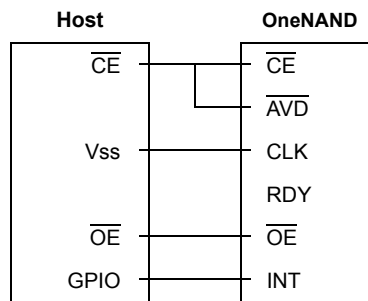

Polling the Interrupt Register Status Bit

An alternate method of determining the end of an operation is to continuously monitor the Interrupt Status Register Bit instead of using the INT pin.

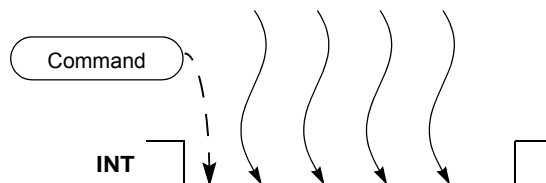

This can be configured in either a synchronous mode or an asynchronous mode.

Technical Notes (Continued)

Synchronous Mode Using Interrupt Status Register Bit Polling

When operating synchronously, \overline{CE} and \overline{AVD} of the OneNAND are tied to \overline{CE} of the Host. CLK, \overline{OE} , and DQ pins on the host and OneNAND are tied together. RDY could be connected as one of following guides.

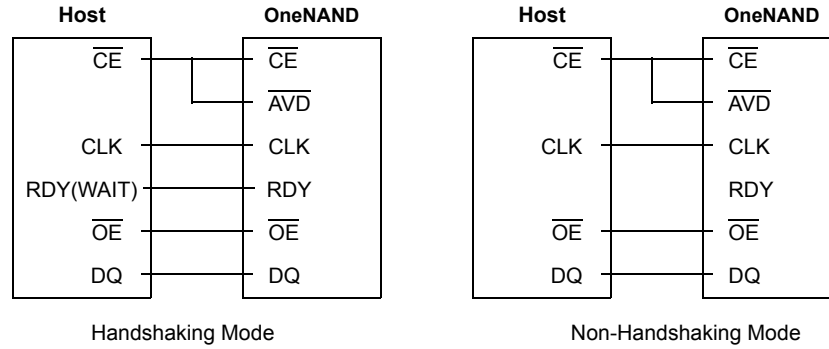

Asynchronous Mode Using Interrupt Status Register Bit Polling

When configured to operate in an asynchronous mode, \overline{CE} and \overline{AVD} of the OneNAND are tied to \overline{CE} of the Host. CLK is tied to the Host Vss (Ground). RDY is tied to a no-connect. \overline{OE} and DQ of the OneNAND and Host are tied together.

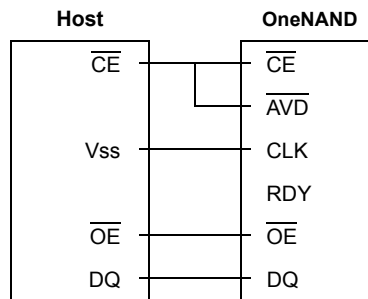

Technical Notes (Continued)

Determining Rp Value

Because the pull-up resistor value is related to tr(INT), an appropriate value can be obtained by the following reference charts.

INT pol = 'High'

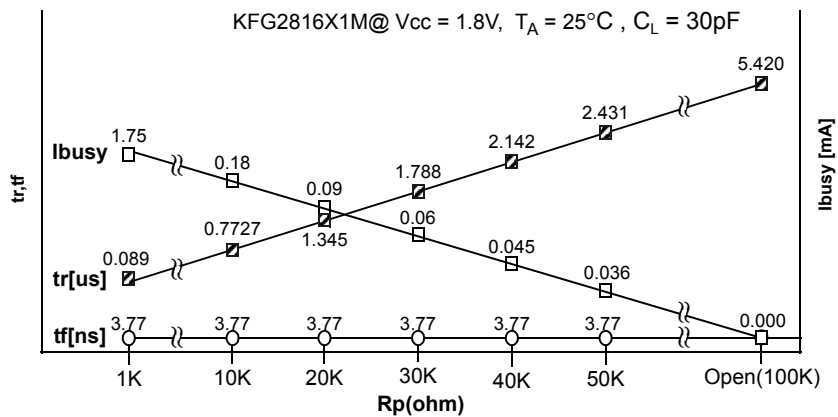
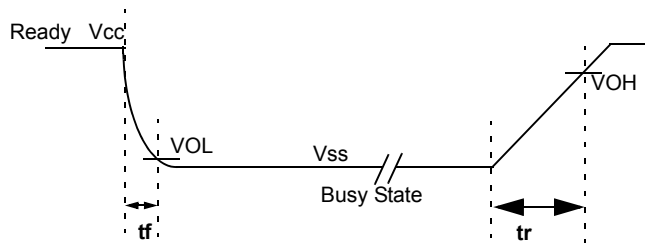
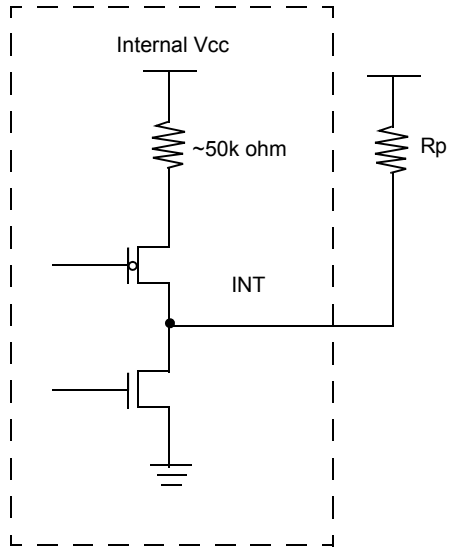

Technical Notes (Continued)

INT pol = 'Low'

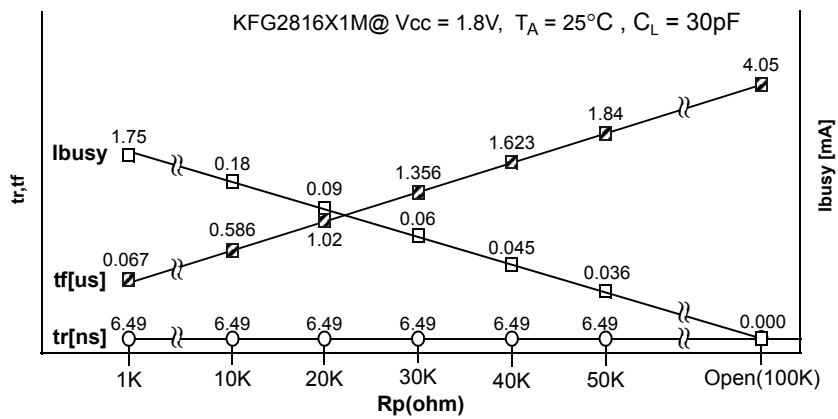
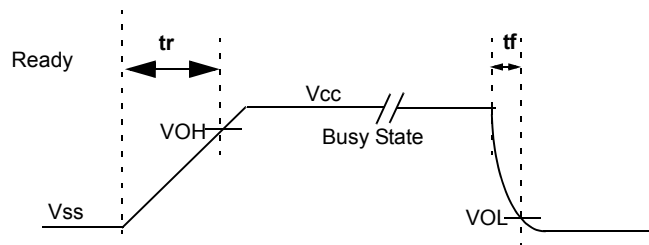
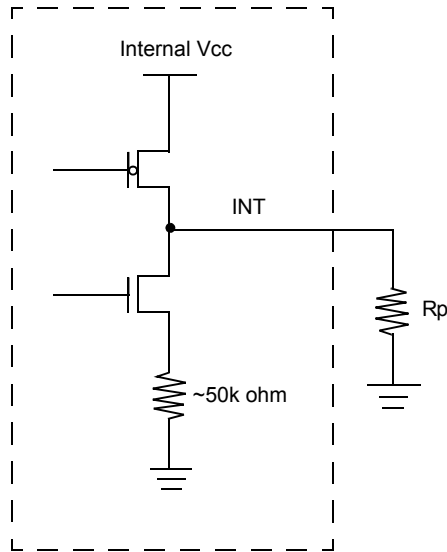

ABSOLUTE MAXIMUM RATINGS

Parameter		Symbol	Rating			Unit
			KFG2816Q1M	KFG2816D1M	KFG2816U1M	
Voltage on any pin relative to Vss	Vcc	Vcc	-0.5 to + 2.45	-0.6 to + 4.6	-0.6 to + 4.6	V
	All Pins	V _{IN}	-0.5 to + 2.45	-0.6 to + 4.6	-0.6 to + 4.6	
Temperature Under Bias	Extended	T _{bias}	-30 to +125	-30 to +125	-30 to +125	°C
	Industrial		-	-	-40 to +125	
Storage Temperature		T _{stg}	-65 to +150	-65 to +150	-65 to +150	°C
Short Circuit Output Current		I _{os}	5	5	5	mA
Operating Temperature	Extended	T _A	-30 to + 85	-30 to + 85	-30 to + 85	°C
	Industrial	T _A	-	-	-40 to + 85	

NOTES:

1. Minimum DC voltage is -0.5V on Input/ Output pins. During transitions, this level should not fall to POR level(typ. 1.5V).
Maximum DC voltage is Vcc+0.6V on input / output pins which, during transitions, may overshoot to Vcc+2.0V for periods <20ns.
2. Permanent device damage may occur if ABSOLUTE MAXIMUM RATINGS are exceeded. Functional operation should be restricted to the conditions detailed in the operational sections of this data sheet. Exposure to absolute maximum rating conditions for extended periods may affect reliability.

9.2 RECOMMENDED OPERATING CONDITIONS (Voltage reference to GND)

Parameter	Symbol	1.8V Device			3.3V Device			Unit
		Min	Typ.	Max	Min	Typ.	Max	
Supply Voltage	Vcc-core	1.7	1.8	1.95	2.7	3.3	3.6	V
	Vcc-IO							
	Vss	0	0	0	0	0	0	

NOTES:

1. The system power should reach 1.7V after POR triggering level(typ. 1.5V) within 400us.
2. Vcc-Core should reach the operating voltage level prior to Vcc-IO or at the same time.

DC CHARACTERISTICS

Parameter	Symbol	Test Conditions	RMS Value						Unit	
			1.8V device			3.3V device				
			Min	Typ	Max	Min	Typ	Max		
Input Leakage Current	I _{LI}	V _{IN} =V _{SS} to V _{CC} , V _{CC} =V _{CCmax}	- 1.0	-	+ 1.0	- 1.0	-	+ 1.0	μA	
Output Leakage Current	I _{LO}	V _{OUT} =V _{SS} to V _{CC} , V _{CC} =V _{CCmax} , CE or OE=V _{IH} (Note 1)	- 1.0	-	+ 1.0	- 1.0	-	+ 1.0	μA	
Active Asynchronous Read Current (Note 2)	I _{CC1}	CE=V _{IL} , OE=V _{IH}	-	8	15	-	10	20	mA	
Active Burst Read Current (Note 2)	I _{CC2}	CE=V _{IL} , OE=V _{IH}	54MHz	-	12	20	-	20	30	mA
			1MHz	-	3	4	-	4	6	mA
Active Write Current (Note 2)	I _{CC3}	CE=V _{IL} , OE=V _{IH}	-	8	15	-	10	20	mA	
Active Load Current (Note 3)	I _{CC4}	CE=V _{IL} , OE=V _{IH} , WE=V _{IH} , V _{IN} =V _{IH} or V _{IL}	-	20	25	-	20	30	mA	
Active Program Current (Note 3)	I _{CC5}	CE=V _{IL} , OE=V _{IH} , WE=V _{IH} , V _{IN} =V _{IH} or V _{IL}	-	20	25	-	20	30	mA	
Erase/Multi Block Erase Current (Note 3)	I _{CC6}	CE=V _{IL} , OE=V _{IH} , WE=V _{IH} , V _{IN} =V _{IH} or V _{IL} , 64blocks	-	15	20	-	18	25	mA	
Standby Current	I _{SB}	CE= RP=V _{CC} ± 0.2V	-	10	50	-	15	50	μA	
Input Low Voltage	V _{IL}	-	-0.5	-	0.4	0	-	0.8	V	
Input High Voltage	V _{IH}	-	V _{CCq} -0.4	-	V _{CCq} +0.4	0.7*V _{Cq}	-	V _{CCq}	V	
Output Low Voltage	V _{OL}	I _{OL} = 100 μA , V _{CC} =V _{CCmin} , V _{CCq} =V _{CCqmin}	-	-	0.2	-	-	0.22*V _{CCq}	V	
Output High Voltage	V _{OH}	I _{OH} = -100 μA , V _{CC} =V _{CCmin} , V _{CCq} =V _{CCqmin}	V _{CCq} -0.1	-	-	0.8*V _{Cq}	-	-	V	

1. CE should be V_{IH} for RDY. IOBE should be '0' for INT.

2. I_{CC} active for Host access

3. I_{CC} active while Internal operation is in progress.

VALID BLOCK

Parameter	Symbol	Min	Typ.	Max	Unit
Valid Block Number	NvB	251	-	256	Blocks

NOTES:

1. The device may include invalid blocks when first shipped. Additional invalid blocks may develop while being used. The number of valid blocks is presented with both cases of invalid blocks considered. Invalid blocks are defined as blocks that contain one or more bad bits. Do not erase or program factory-marked bad blocks.
2. The 1st block, which is placed on 00h block address, is fully guaranteed to be a valid block.

CAPACITANCE ($T_A = 25\text{ }^\circ\text{C}$, $V_{CC} = 1.8\text{V}/3.3\text{V}$, $f = 1.0\text{MHz}$)

Item	Symbol	Test Condition	Min	Max	Unit
Input Capacitance	C _{IN1}	V _{IN} =0V	-	10	pF
Control Pin Capacitance	C _{IN2}	V _{IN} =0V	-	10	pF
Output Capacitance	C _{OUT}	V _{OUT} =0V	-	10	pF

NOTE : Capacitance is periodically sampled and not 100% tested.

AC TEST CONDITION ($V_{CC} = 1.8\text{V}/3.3\text{V}$)

Parameter	Value
Input Pulse Levels	0V to V _{CC}
Input Rise and Fall Times	CLK
	other inputs
Input and Output Timing Levels	V _{CC} /2
Output Load	C _L = 30pF

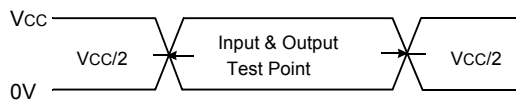

Input Pulse and Test Point

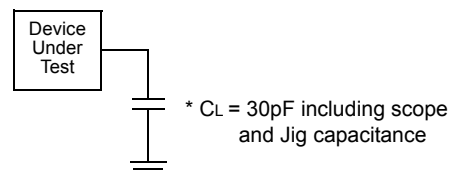

Output Load

Synchronous Burst Read

Parameter	Symbol	KFG2816X1M		Unit
		Min	Max	
Clock	CLK	1	54	MHz
Clock Cycle	t _{CLK}	18.5	-	ns
Initial Access Time(at 54MHz)	t _{IAA}	-	76	ns
Burst Access Time Valid Clock to Output Delay	t _{BA}	-	14.5	ns
$\overline{\text{AVD}}$ Setup Time to CLK	t _{AVDS}	7	-	ns
$\overline{\text{AVD}}$ Hold Time from CLK	t _{AVDH}	7	-	ns
Address Setup Time to CLK	t _{ACS}	7	-	ns
Address Hold Time from CLK	t _{ACH}	7	-	ns
Data Hold Time from Next Clock Cycle	t _{BDH}	4	-	ns
Output Enable to Data	t _{OE}	-	20	ns
$\overline{\text{CE}}$ Disable to Output High Z	t _{CEZ} ¹⁾	-	20	ns
$\overline{\text{OE}}$ Disable to Output High Z	t _{OEZ} ¹⁾	-	17	ns
$\overline{\text{CE}}$ Setup Time to CLK	t _{CES}	7	-	ns
CLK High or Low Time	t _{CLKH/L}	t _{CLK} /3	-	ns
CLK ²⁾ to RDY valid	t _{RDYO}	-	14.5	ns
CLK to RDY Setup Time	t _{RDYA}	-	14.5	ns
RDY Setup Time to CLK	t _{RDYS}	4	-	ns
$\overline{\text{CE}}$ low to RDY valid	t _{CER}	-	15	ns

Note

1. If $\overline{\text{OE}}$ is disabled at the same time or before $\overline{\text{CE}}$ is disabled, the output will go to high-z by t_{OEZ}(max. 17ns).
 If $\overline{\text{CE}}$ is disabled at the same time or before $\overline{\text{OE}}$ is disabled, the output will go to high-z by t_{CEZ}(max. 20ns).
 If $\overline{\text{CE}}$ and $\overline{\text{OE}}$ are disabled at the same time, the output will go to high-z by t_{OEZ}(max. 17ns).
 These parameters are not 100% tested.
2. It is the following clock of address fetch clock.

SWITCHING WAVEFORMS

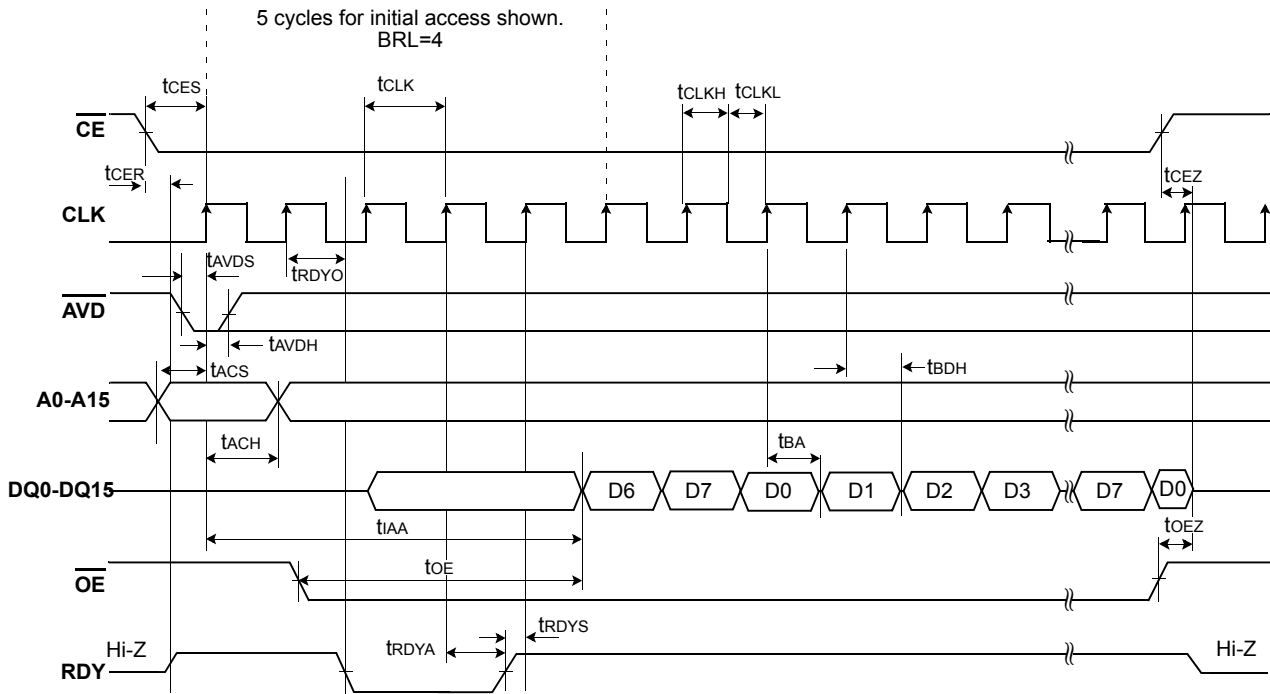

Figure 28. 8 Word Linear Burst Mode with Wrap Around

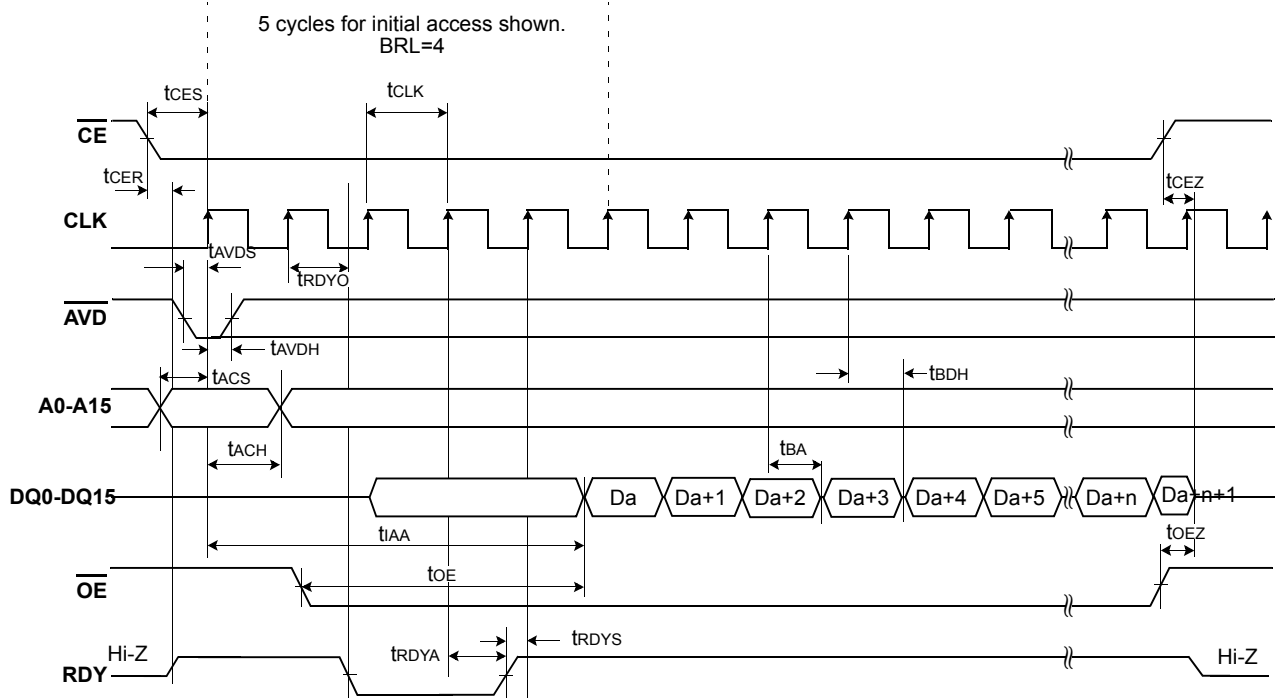

Figure 29. Continuous Linear Burst Mode with Wrap Around

NOTE: In order to avoid a bus conflict the \overline{OE} signal is enabled on the next rising edge after \overline{AVD} is going high.

Asynchronous Read

Parameter	Symbol	KFG2816X1M		Unit
		Min	Max	
Access Time from \overline{CE} Low	tCE	-	76	ns
Asynchronous Access Time from \overline{AVD} Low	tAA	-	76	ns
Asynchronous Access Time from address valid	tACC	-	76	ns
Read Cycle Time	tRC	76	-	ns
\overline{AVD} Low Time	tAVDP	12	-	ns
Address Setup to rising edge of \overline{AVD}	tAAVDS	7	-	ns
Address Hold from rising edge of \overline{AVD}	tAAVDH	7	-	ns
Output Enable to Output Valid	tOE	-	20	ns
\overline{CE} Setup to \overline{AVD} falling edge	tCA	0	-	ns
\overline{CE} Disable to Output & RDY High Z ¹⁾	tCEZ	-	20	ns
\overline{OE} Disable to Output & RDY High Z ¹⁾	tOEZ	-	17	ns

NOTE:

1. If \overline{OE} is disabled at the same time or before \overline{CE} is disabled, the output will go to high-z by tOEZ(max. 17ns).
 If \overline{CE} is disabled at the same time or before \overline{OE} is disabled, the output will go to high-z by tCEZ(max. 20ns).
 If \overline{CE} and \overline{OE} are disabled at the same time, the output will go to high-z by tOEZ(max. 17ns).
 These parameters are not 100% tested.

SWITCHING WAVEFORMS

Case 1 : Valid Address and \overline{AVD} Transition occur before \overline{CE} is driven to Low

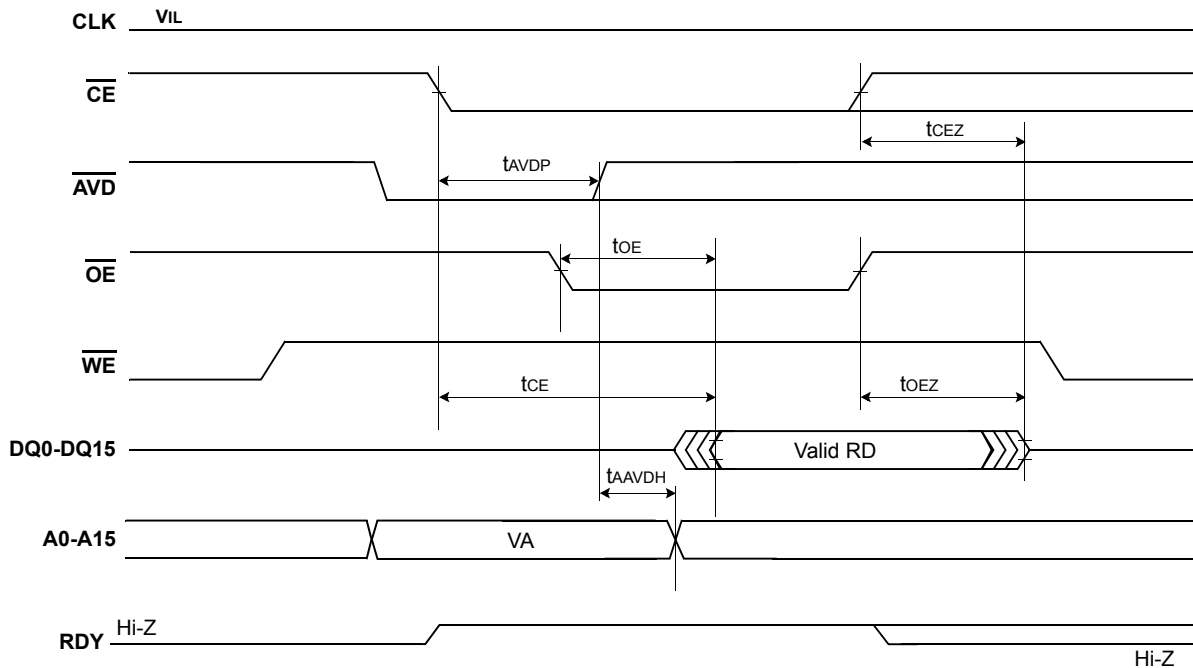

Figure 30. Asynchronous Read Mode(\overline{AVD} toggling)

Case 2 : $\overline{\text{AVD}}$ Transition occurs after $\overline{\text{CE}}$ is driven to Low and Valid Address Transition occurs before $\overline{\text{AVD}}$ is driven to Low

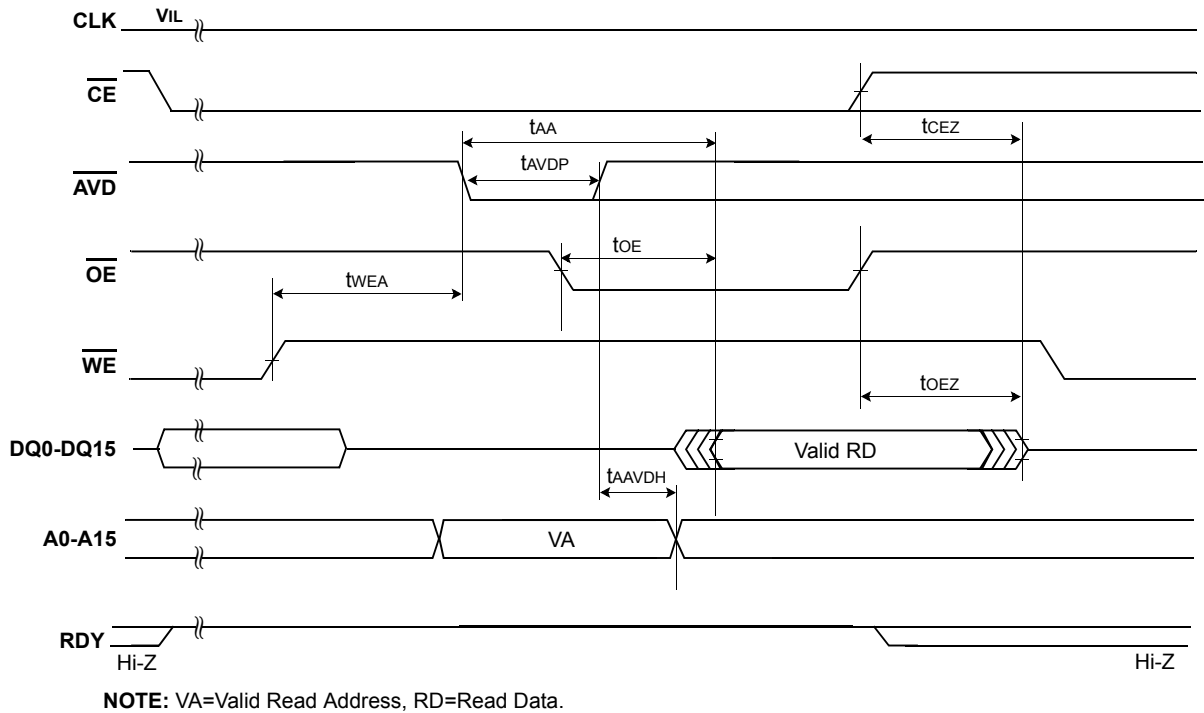

Figure 31. Asynchronous Read Mode($\overline{\text{AVD}}$ toggling)

Case 3 : $\overline{\text{AVD}}$ Transition occur after $\overline{\text{CE}}$ is driven to Low and Valid Address Transition occurs after $\overline{\text{AVD}}$ is driven to Low

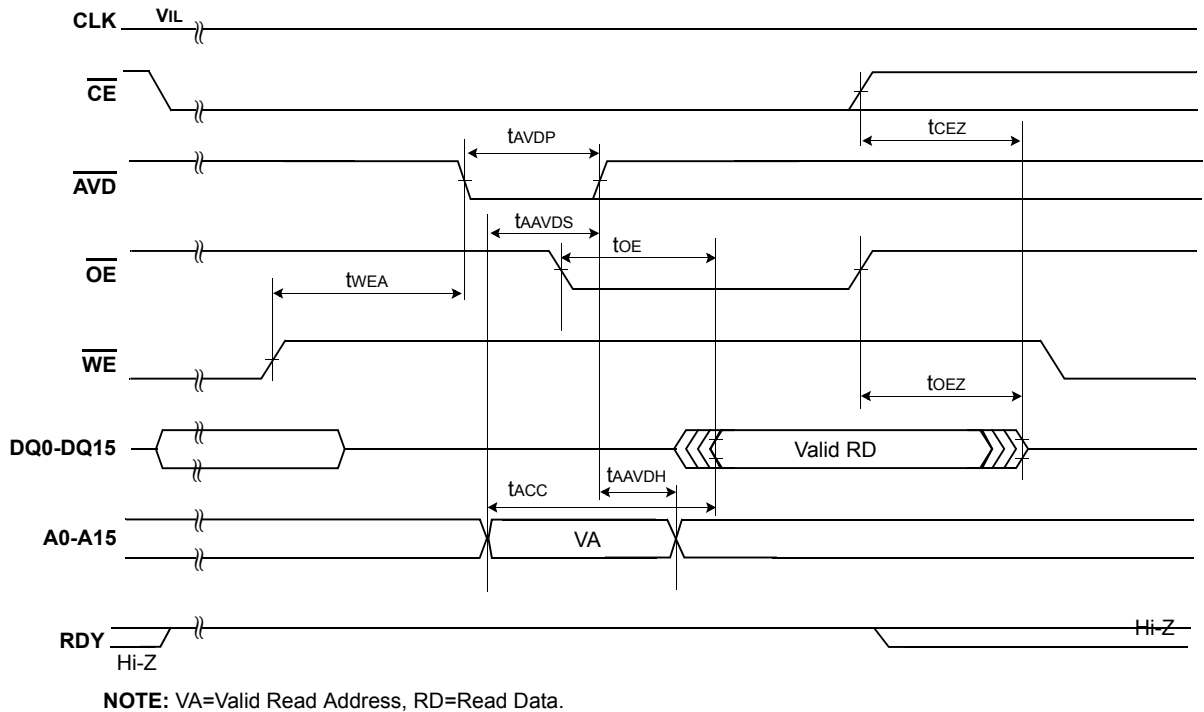
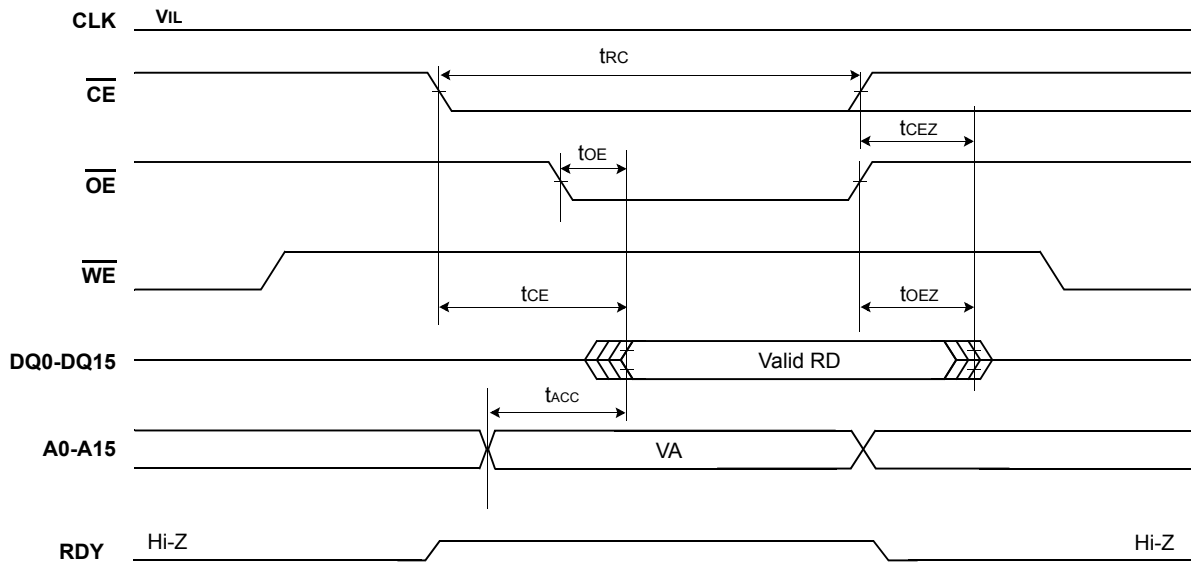

Figure 32. Asynchronous Read Mode($\overline{\text{AVD}}$ toggling)

Case 4 : $\overline{\text{AVD}}$ is tied to $\overline{\text{CE}}$



NOTE: VA=Valid Read Address, RD=Read Data.

Figure 33. Asynchronous Read Mode($\overline{\text{AVD}}$ tied to $\overline{\text{CE}}$)

AC CHARACTERISTICS
Asynchronous write operation

Parameter	Symbol	KFG2816X1M			Unit
		Min	Typ	Max	
\overline{WE} Cycle Time	tWC	70	-	-	ns
\overline{AVD} low pulse width	tAVDP	12	-	-	ns
Address Setup to rising edge of \overline{AVD}	tAAVDS	7	-	-	ns
Address Setup to falling edge of \overline{WE}	tAWES	0			
Address Hold to rising edge of \overline{AVD}	tAAVDH	7	-	-	ns
Address Hold to rising edge of \overline{WE}	tAH	10			ns
Data Setup to rising edge of \overline{WE}	tDS	10	-	-	ns
Data Hold from rising edge of \overline{WE}	tDH	4	-	-	ns
\overline{CE} Setup to falling edge of \overline{WE}	tCS	0	-	-	ns
\overline{CE} Hold from rising edge of \overline{WE}	tCH1	0	-	-	ns
\overline{AVD} toggled					
\overline{CE} Hold from rising edge of \overline{WE}	tCH2	10	-	-	ns
\overline{AVD} tied to \overline{CE}					
\overline{WE} Pulse Width Low	tWPL	40	-	-	ns
\overline{WE} Pulse Width High	tWPH	30	-	-	ns
\overline{AVD} Disable to \overline{WE} Disable	tVLWH	15	-	-	ns
\overline{WE} Disable to \overline{AVD} Enable	tWEA	15	-	-	ns

Case 1 : $\overline{\text{AVD}}$ is toggled every write cycle

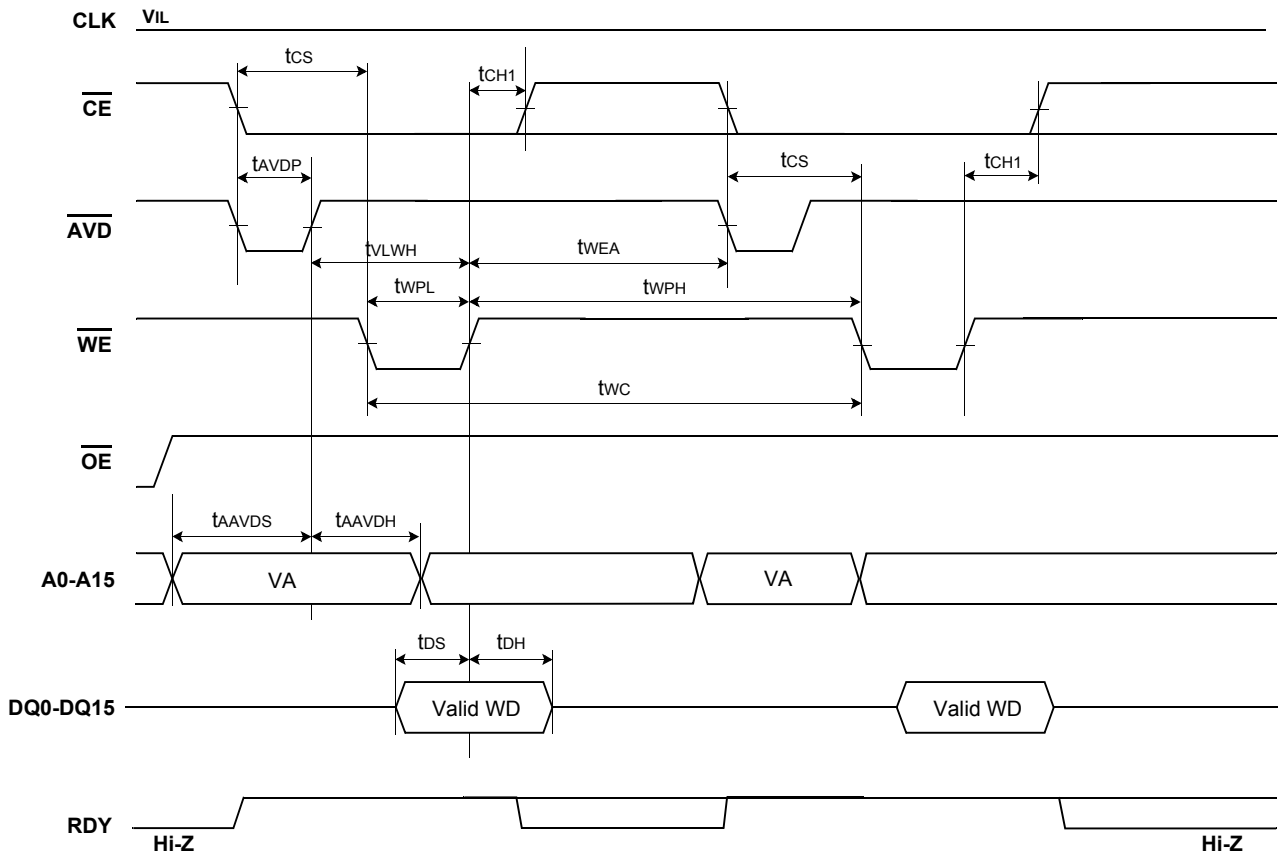

NOTE: VA=Valid Read Address, WD=Write Data.

Figure 34. Latched Asynchronous Write Mode($\overline{\text{AVD}}$ toggling)

Case 2 : $\overline{\text{AVD}}$ is synchronized with $\overline{\text{CE}}$

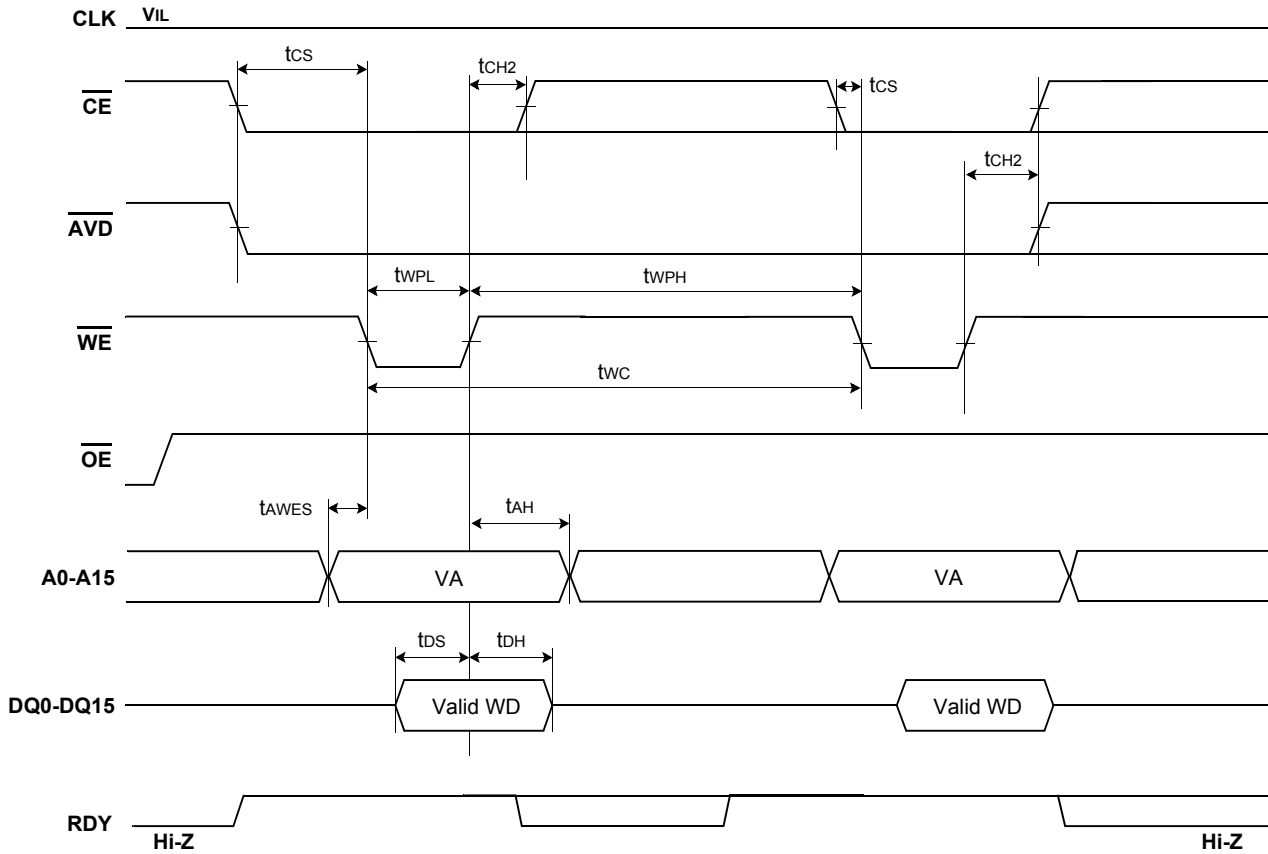

NOTE: VA=Valid Read Address, WD=Write Data.

Figure 35. Asynchronous Write Mode($\overline{\text{AVD}}$ toggling)

Case 3 : $\overline{\text{AVD}}$ is tied to $\overline{\text{CE}}$

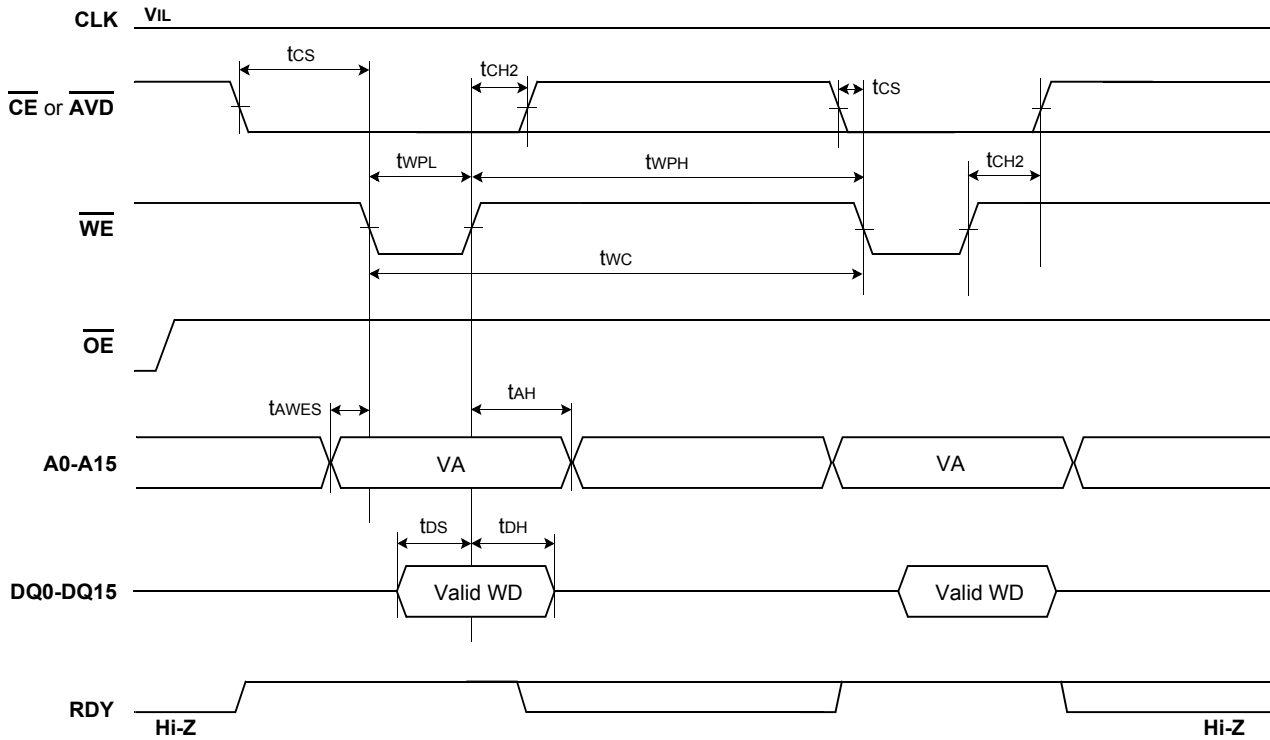

NOTE: VA=Valid Read Address, WD=Write Data.

Figure 36. Asynchronous Write Mode($\overline{\text{AVD}}$ tied to $\overline{\text{CE}}$)

Reset

Parameter	Symbol	KFG2816X1M		Unit
		Min	Max	
\overline{RP} & Reset Command Latch(During Load Routines) to INT High (Note)	tRST	-	10	μ s
\overline{RP} & Reset Command Latch(During Program Routines) to INT High (Note)	tRST	-	20	μ s
\overline{RP} & Reset Command Latch(During Erase Routines) to INT High (Note)	tRST	-	500	μ s
\overline{RP} & Reset Command Latch(NOT During Internal Routines) to Read Mode (Note)	tRST	-	10	μ s
INT High to Read Mode (Note)	tReady	200	-	ns
\overline{RP} Pulse Width	tRP	200	-	ns

NOTE: These parameters are tested based on INT bit of interrupt register. Because the time on INT pin is related to the pull-up and pull-down resistor value. Please refer to page 66 and 67.

SWITCHING WAVEFORMS

Warm Reset

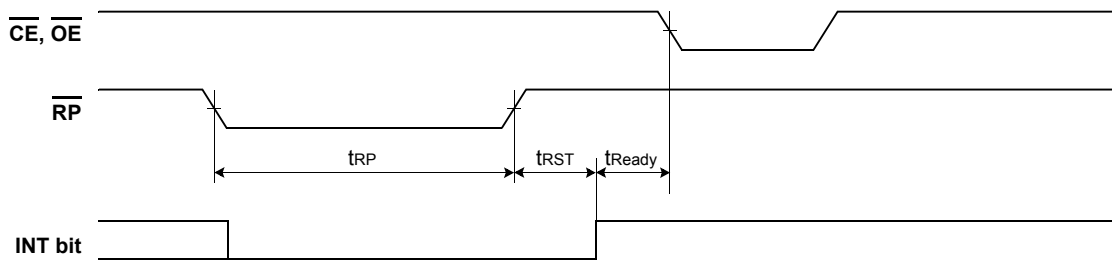

Hot Reset

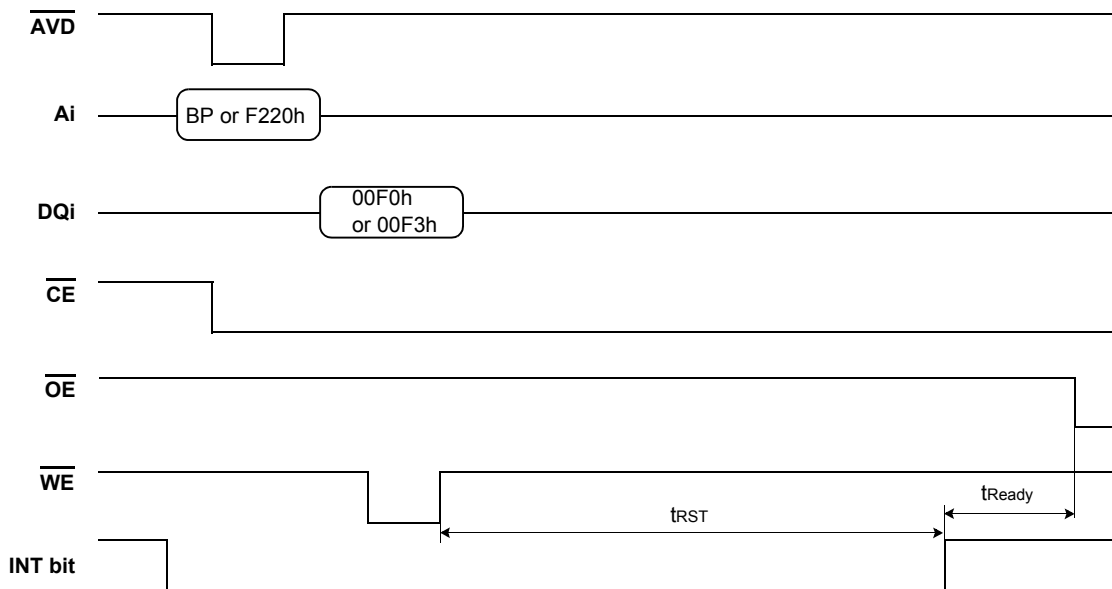

Figure 37. Reset Timing

Performance

Parameter	Symbol	Min	Typ	Max	Unit	
Sector Load time(Note 1)	tRD1	-	35	45	μs	
Page Load time(Note 1)	tRD2	-	50	75	μs	
Sector Program time(Note 1)	tPGM1	-	320	720	μs	
Page Program time(Note 1)	tPGM2	-	350	750	μs	
OTP Access Time(Note 1)	tOTP	-	600	1000	ns	
Lock/Unlock/Lock-tight Time(Note 1)	tLOCK	-	600	1000	ns	
Erase Suspend Time(Note 1)	tESP	-	400	500	μs	
Erase Resume Time(Note 1)	1 Block	tERS1	-	2	3	ms
	2~64 Blocks	tERS2	-	4	5	ms
Number of Partial Program Cycles in the sector (Including main and spare area)	NOP	-	-	2	cycles	
Block Erase time (Note 1)	1 Block	tBERS1	-	2	3	ms
	2~64 Blocks	tBERS2	-	4	5	ms
Multi Block Erase Verify Read time(Note 1)	tRD3	-	115	135	μs	

NOTES:

1. These parameters are tested based on INT bit of interrupt register. Because the time on INT pin is related to the pull-up and pull-down resistor value. Please refer to page 66 and 67.

SWITCHING WAVEFORMS

Load Operations

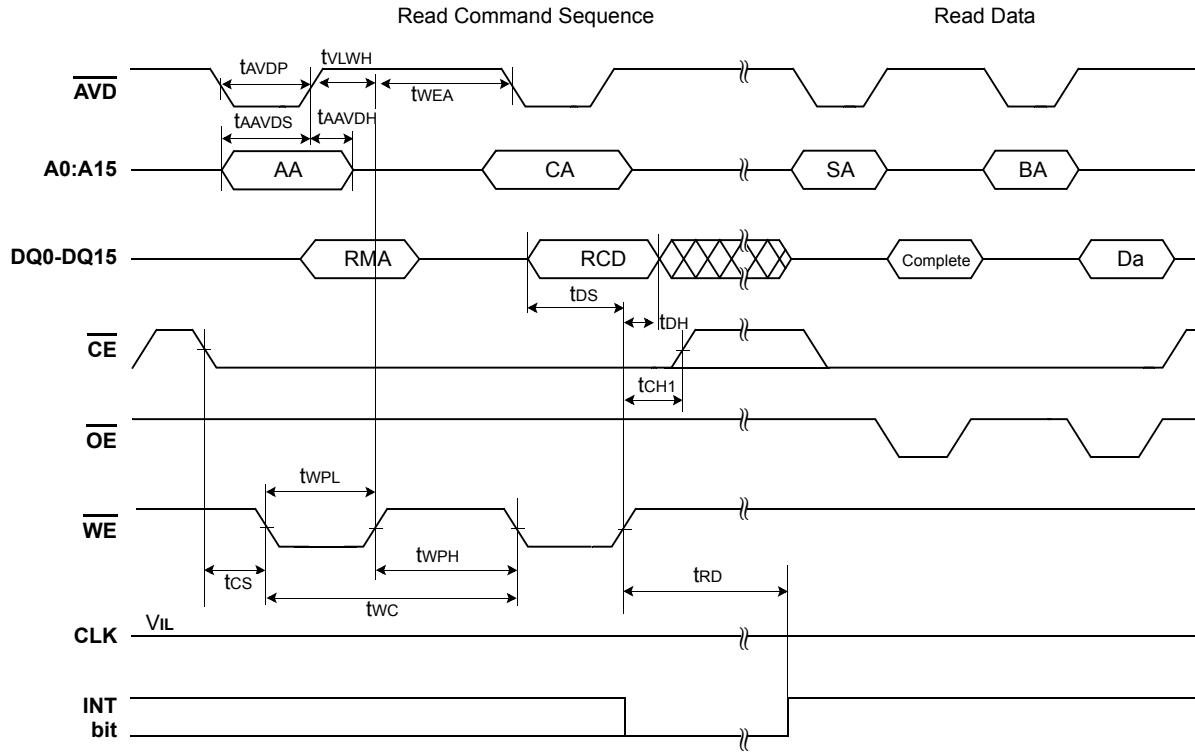

Figure 38. Load Operation Timing

NOTES:

1. AA = Address of address register
 CA = Address of command register
 LCD = Load Command
 LMA = Address of memory to be loaded
 BA = Address of BufferRAM to load the data
 BD = Program Data
 SA = Address of status register
2. "In progress" and "complete" refer to status register
3. Status reads in this figure is asynchronous read, but status read in synchronous mode is also supported.

SWITCHING WAVEFORMS

Program Operations

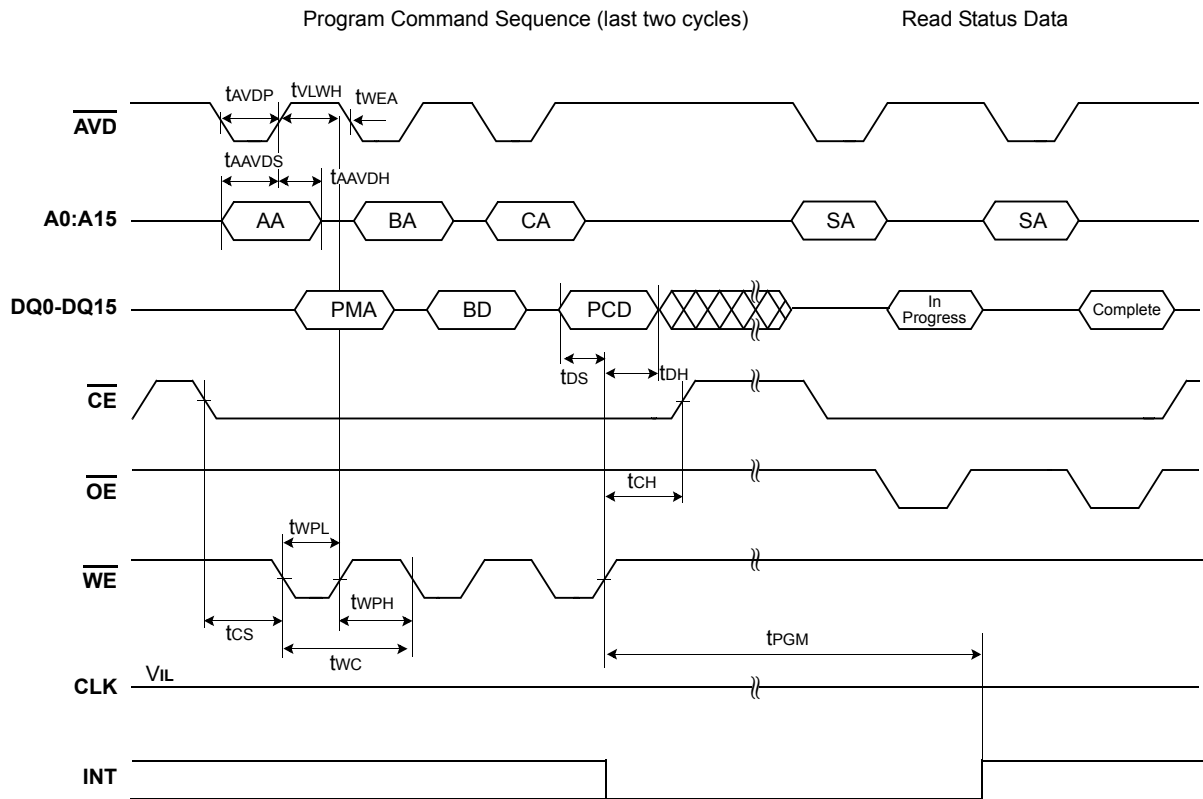

Figure 39. Program Operation Timing

NOTES:

1. AA = Address of address register
 CA = Address of command register
 PCD = Program Command
 PMA = Address of memory to be programmed
 BA = Address of BufferRAM to load the data
 BD = Program Data
 SA = Address of status register
2. "In progress" and "complete" refer to status register
3. Status reads in this figure is asynchronous read, but status read in synchronous mode is also supported.

SWITCHING WAVEFORMS

Erase Operation

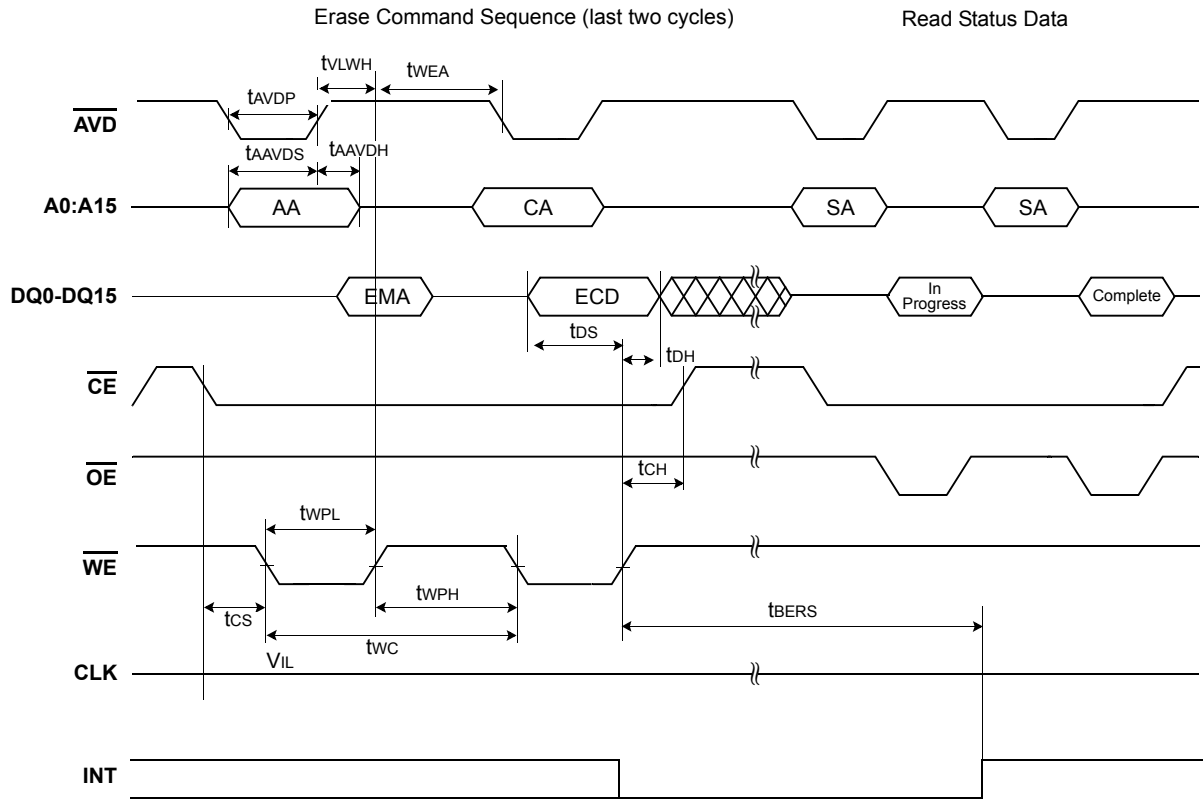
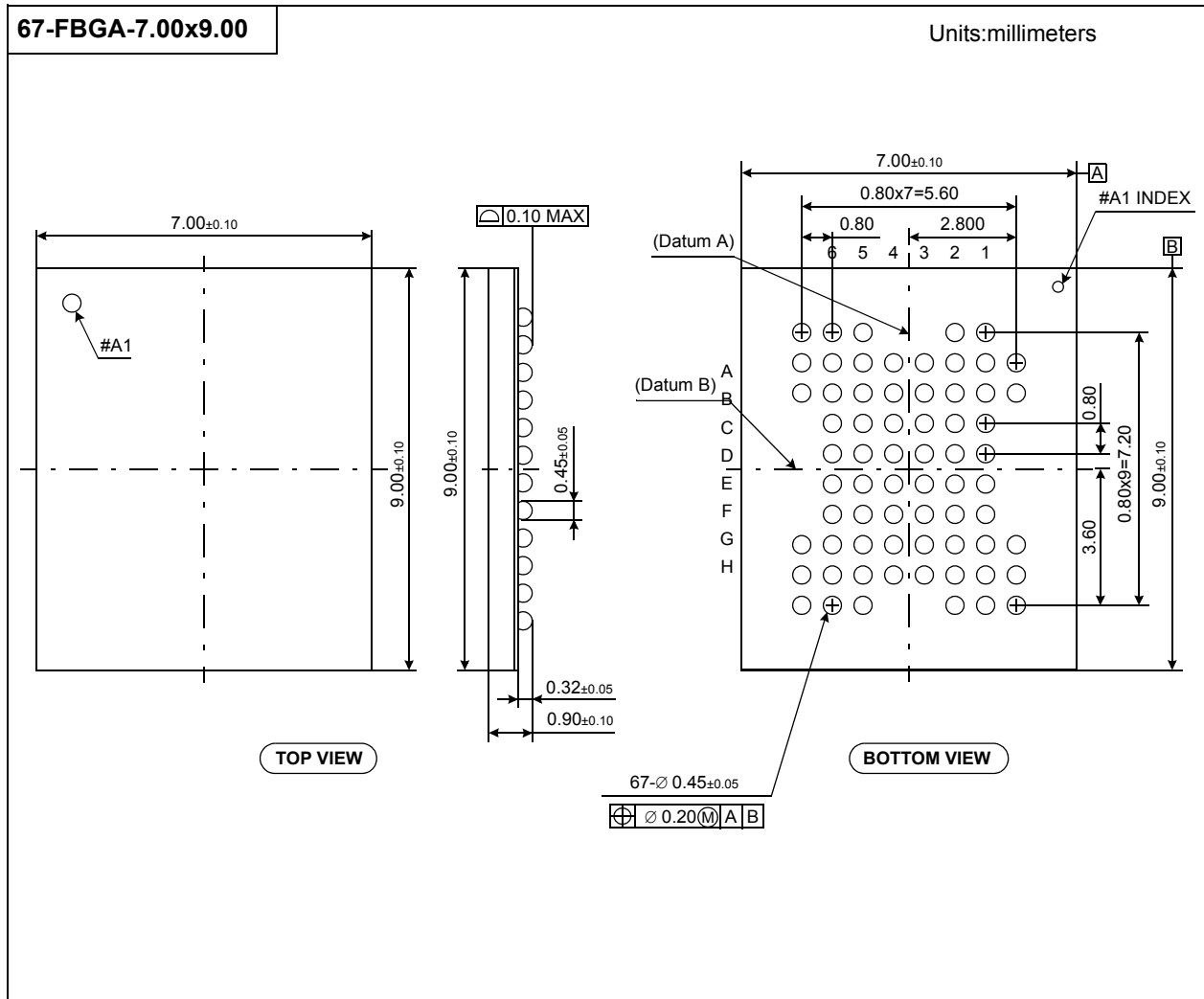

Figure 40. Block Erase Operations

NOTES:

1. AA = Address of address register
 CA = Address of command register
 ECD = Erase Command
 EMA = Address of memory to be erased
 SA = Address of status register
2. "In progress" and "complete" refer to status register
3. Status reads in this figure is asynchronous read, but status read in synchronous mode is also supported.

OneNAND128 PACKAGE DIMENSIONS



PACKAGE DIMENSIONS

48-PIN LEAD/LEAD FREE PLASTIC THIN SMALL OUT-LINE PACKAGE TYPE(I)

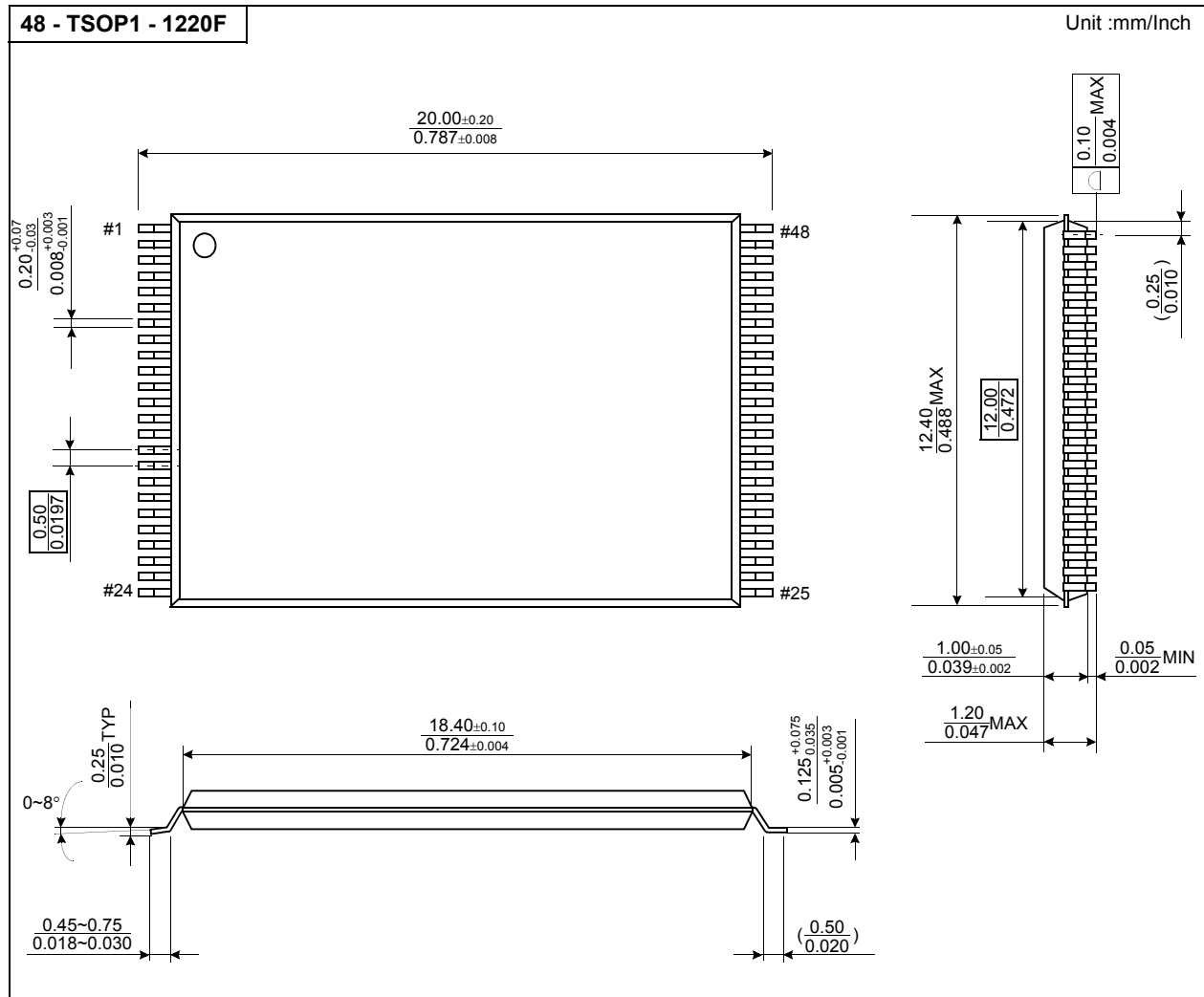

ORDERING INFORMATION

