

CAN Transceiver with Voltage Regulator

FEATURES

- DeviceNet, SDS, ISO 11898 Compatible
- High Speed, up to 1Mbps
- Differential Transmitter and Receiver bus interface
- -25V to +18V Protection on CANH and CANL
- Loss of Ground Protection
- High Differential Input Impedance
- Supports 110 nodes or more
- Operates over -25°C to +85°C
- Unitrode DeviceNet ID#107

DESCRIPTION

The UC5351 Control Area Network (CAN) Transceiver is designed for industrial applications employing the CAN serial communications physical layer per the ISO 11898 standard. The device is a high speed transceiver plus voltage regulator designed for use up to 1Mbps. Especially designed for hostile environments, this device features cross-wire and over voltage protection, thermal shutdown, a wide common mode range, and loss of ground protection.

The UC5351 CAN Transceiver interfaces the single ended CAN Controller with the differential CAN Bus found in industrial and automotive applications. Performance features include high input impedance, a symmetrical differential signal driver, and low propagation delay that improve bus bandwidth and length, while reducing reflection and distortion. Reduced reflection and distortion results in increases of effective bus length and bandwidth.

The on-board regulator permits direct connection to a +8V to 24V power bus and supply power to the transceiver with 40mA of reserve output current to power external components.

The transceiver operates over a wide temperature range, -25°C to 85°C, and is available in a 16-pin power SOIC package.

Inputs		System Mode	Output Mode	Outputs	
TxD	Rs			VCANH - VCANL	RxD
0	0	High Speed	Dominant	1.5V to 3V	0
1	0	High Speed	Recessive	-120mV to +12mV	1
High Z	0	High Speed	Recessive	-120mV to +12mV	1
X	1	Standby		high Z	A & "0" @ Bus = Dominant A & "0" @ Bus = Recessive



BLOCK DIAGRAM

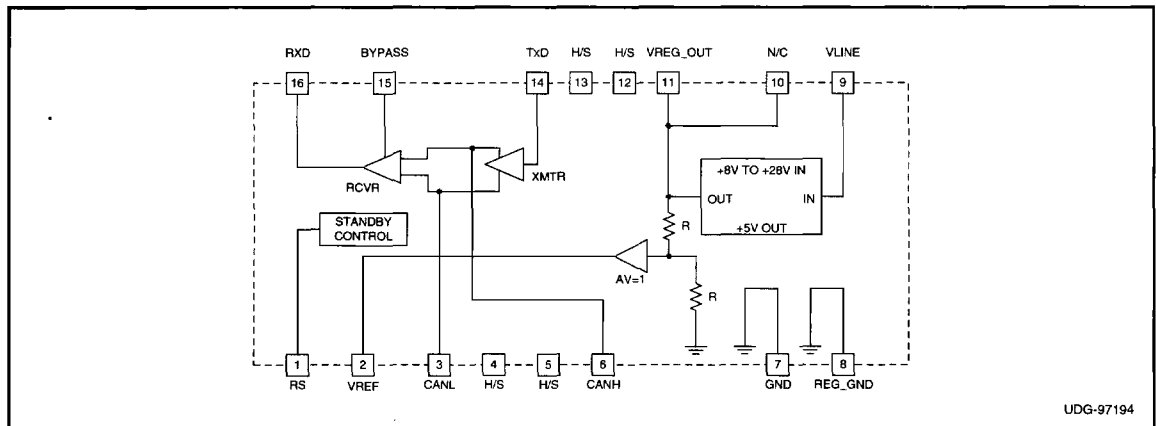

UDG-97194

ABSOLUTE MAXIMUM RATINGS

Supply Voltage -0.3V to +36V
 TXD, RXD, VREF, RS -0.3V to VCC +0.3V
 CANL, CANH 8V < VLINE < 28V -8V to +36V
 Non-Destructive, Non-Operative -8V to +32V
 Transient, Schaffner Test (Figure 1) -150V to +100V
 Operating Temperature -25°C to +85°C
 Storage Temperature -65°C to +150°C
 Junction Temperature -55°C to +150°C
 Lead Temperature (Soldering, 10 sec) +300°C
*Currents are positive into, negative out of the specified terminal.
 Consult Packaging Section of the Databook for thermal limitations and consideration of packages.*

CONNECTION DIAGRAM

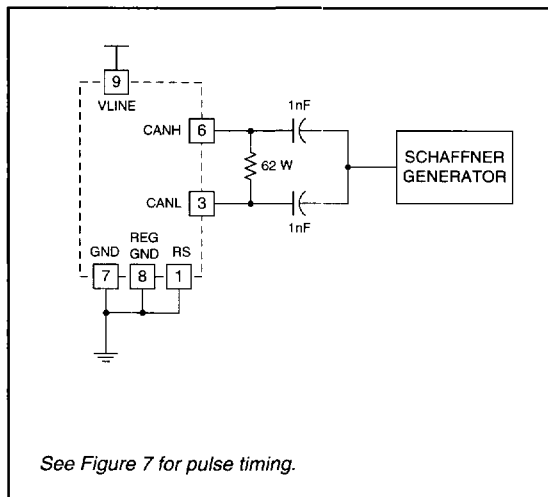
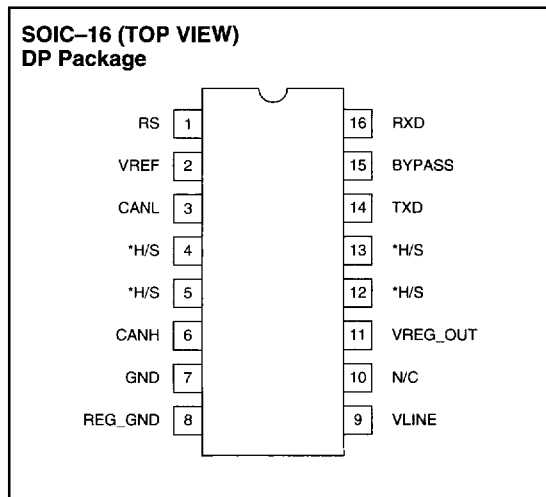

**Warning: H/S pins are connected to the substrate which must float, attach all four pins to at least 0.5 square inch of etch.
DO NOT ATTACH TO GROUND!*

ELECTRICAL CHARACTERISTICS (Total Device) Unless otherwise stated, the device is cisconnected from the bus line; VLINE = 10V; Io(VREG_OUT) = -40mA; CVLINE=0.33µF; CVREG_OUT = 0.1µF; CBYPASS = 0.1µF; 60Ω in parallel with 100pF between CANH and CANL; Tj = -25°C to +150°C. VR = VREG_OUT Voltage.

PARAMETER	TEST CONDITIONS	MIN	TYP	MAX	UNITS
Section					
Supply Voltage (VLINE)		8		28	V
Supply Current (VLINE)	Dominant, TXD = 1V; Io(VREG_OUT) = 0			75	mA
	Recessive, TXD = 4V; Io(VREG_OUT) = 0		12	17	mA
	Standby, RS = 4V; Io(VREG_OUT) = 0		6.5	9	mA
Output Voltage (VREG_OUT)	Tj = 25°C	4.8	5	5.2	V
	1mA < Io(VREG_OUT) < 40mA; 8V < VLINE < 28V	4.75		5.25	V
Line Regulation (VREG_OUT)	Tj = 25°C, 8V < VLINE < 28V			90	mV
Load Regulation (VREG_OUT)	Tj = 25°C, 1mA < Io(VREG_OUT) < 40mA			60	mV
Ripple Rejection (VREG_OUT)	f=120Hz, 8V < VLINE < 16V		47		dB
RS Input Current			-5	5	µA
RS Input Voltage = Logic 1	Standby	(0.75)•VR			V
RS Input Voltage = Logic 0	High Speed			(0.3)•VR	V

ELECTRICAL CHARACTERISTICS (Total Device) Unless otherwise stated, the device is disconnected from the bus line; VLINE = 10V; I_o(VREG_OUT) = -40mA; C_{VLINE}=0.33μF; C_{VREG_OUT} = 0.1μF; C_{BPASS} = 0.1μF; 60Ω in parallel with 100pF between CANH and CANL; T_J = -25°C to +150°C. V_R = VREG_OUT Voltage.

PARAMETER	TEST CONDITIONS	MIN	TYP	MAX	UNITS
Transmitter Voltage Input = Logic 1	Transmitter Output Recessive	(0.7)•V _R			V
Transmitter Voltage Input = Logic 0	Transmitter Output Dominant			0.3	V
Transmitter Current Input at Logic 1	TXD = 4V			30	μA
Transmitter Current Input at Logic 0	TXD = 1V	-30		30	μA
Receiver Voltage Output = Logic 1	RXD = -100μA	(0.8)•V _R			V
Receiver Voltage Output = Logic 0	RXD = 1mA			(0.2)•V _R	V
	RXD = 10mA			1.5	V
CANH, CANL Input Resistance	No Load	34	43	54	kΩ
Differential Input Resistance	No Load	68	86	108	kΩ
CANH, CANL Input Capacitance	(Note 1)			20	pF
Differential Input Capacitance	(Note 1)			10	pF
Reference Output Voltage	I (VREF) = ±50μA	(0.45)•V _R		(0.55)•V _R	V

Note: Guaranteed by design. Not 100% tested in production.

ELECTRICAL CHARACTERISTICS (DC Parameters for Recessive State) Unless otherwise stated, the device is disconnected from the bus line; 60Ω in parallel with 100pF load between CANH and CANL.

PARAMETER	TEST CONDITIONS	MIN	TYP	MAX	UNITS
V _{CANH} , V _{CANL}	No Load, TXD = 4V (Figure 2)	2	2.5	3	V
Differential Output Transmitter (V _{CANH} , V _{CANL})	No Load, TXD = 4V (Figure 2)	-500	0	50	mV
Differential Input Receiver		-1		0.4	V
Differential Input Resistance	No Load	68		108	kΩ
Differential Input Receiver	Common Mode Range = -7 V to +12V, TXD = 4V, CANH, CANL Externally Driven (Figure 3)	-1		0.40	V
Differential Input Resistance	No Load	68		108	kΩ

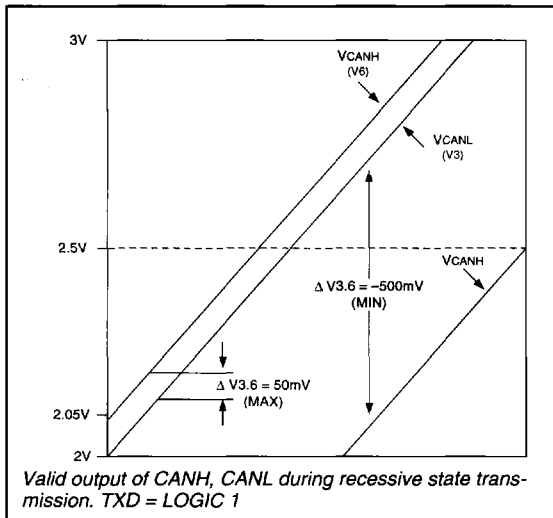

Figure 2. Recessive State Voltage Diagram

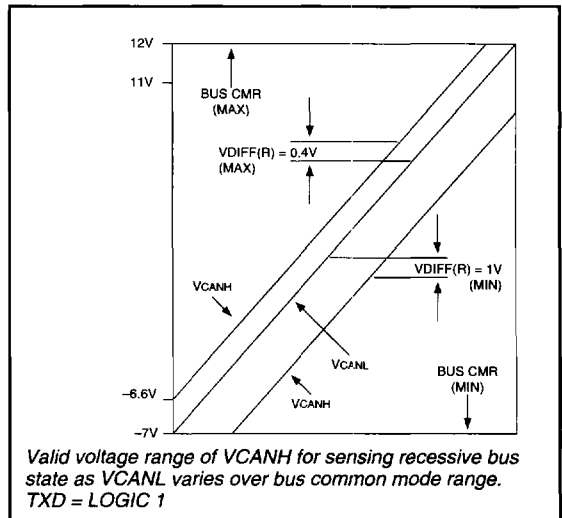

Figure 3. Recessive State Voltage Diagram

**ELECTRICAL CHARACTERISTICS
(DC Parameters for Dominant State)**

Unless otherwise stated, the device is disconnected from the bus line; 60Ω in parallel with 100pF load between CANH and CANL.

PARAMETER	TEST CONDITIONS	MIN	TYP	MAX	UNITS
CANH Output Voltage (VCANH)	TXD = 1V (Figure 4)	2.75	3.5	4.5	V
CANL Output Voltage (VCANL)	TXD = 1V (Figure 4)	0.5	1.5	2.25	V
Differential Output Transmitter (VCANH – VCANL)	TXD = 1V (Figure 4)	1.5	2	3	V
Differential Input Transmitter (VDIFF(D))	Common Mode Range = -7V to +12V; TXD = 4V, CANH, CANL Externally Driven (Figure 5)	0.9		5	V

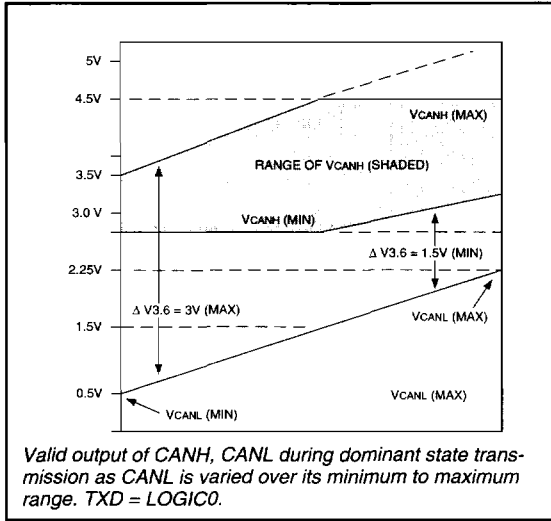

Figure 4. Dominant State Voltage Diagram

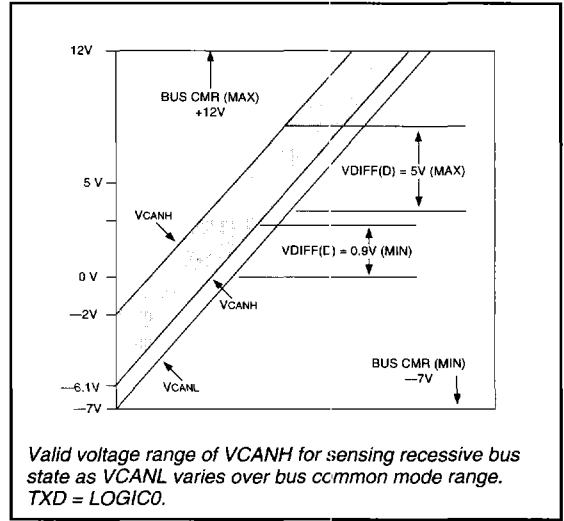

Figure 5. Dominant State Voltage Diagram

TRANSMITTER CHARACTERISTICS

Unless otherwise stated, the device is disconnected from the bus line; 60Ω in parallel with 100pF load between CANH and CANL.

PARAMETER	TEST CONDITIONS	MIN	TYP	MAX	UNITS
Differential Output Transmitter (VCANH – VCANL)	Dominant Mode	1.5	2	3	V
	Recessive Mode	-500		50	mV
Delay From TXD to Bus Active (TON (TXD))	(Figure 6)			75	nS
Delay From TXD to Bus Active (TOFF (TXD))	60Ω Across CANH and CANL (Figure 6)			75	nS

RECEIVER CHARACTERISTICS

Unless otherwise stated, the device is disconnected from the bus line; 60Ω in parallel with 100pF load between CANH and CANL.

PARAMETER	TEST CONDITIONS	MIN	TYP	MAX	UNITS
Differential Input Transmitter (VCANH – VCANL)	Dominant Mode, TXD = 4V	0.9			V
	Recessive Mode, TXD = 4V		150		mV
Differential Input Hysteresis	TXD = 4V		150		mV
Delay from Bus to RXD (TON)	Inactive to Active Bus (Figure 6)			150	nS
Delay from Bus to RXD (TOFF)	Active to Inactive Bus; 60Ω Across CANH and CANL (Figure 6)			150	nS

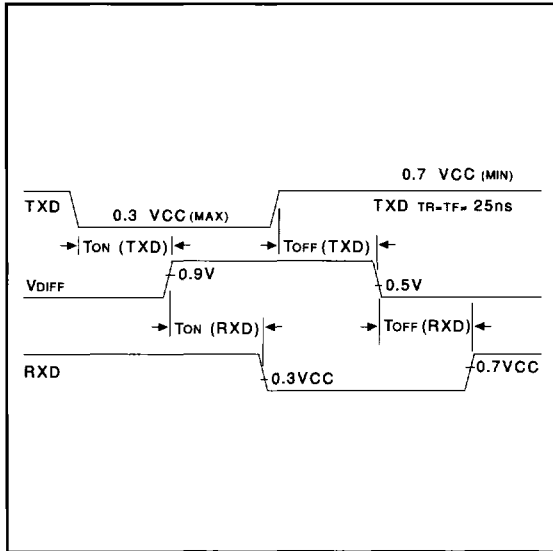

Figure 6. Transceiver AC Response

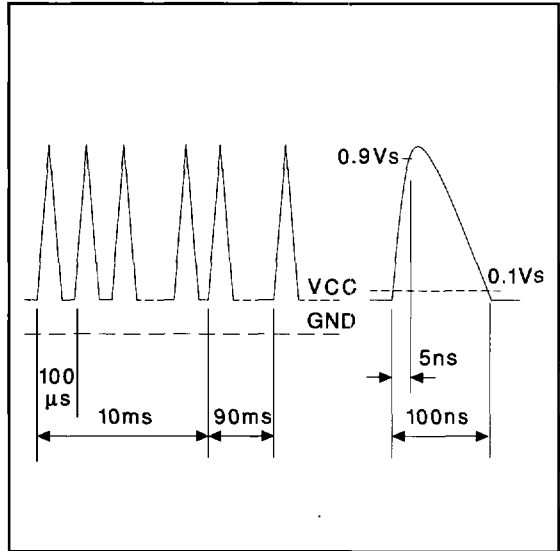

Figure 7. Timing Diagram for Schaffner Tests

Magnitude Specifications for Vs		
ISO	DIN-40839-1	Schaffner
DP7637/1	(Draft)	NSG500C/506C
Up to 150V	Up to 150V	40V to 200V