

## IBM® COMPATIBLE, SIX CHANNEL S/D OR R/D CONVERTER CARD

### DESCRIPTION

The SDC-36015 is a versatile, full-size IBM PC® card designed for one to six channels of resolver-to-digital or synchro-to-digital conversion. The SDC-36015 uses the RDC-19200 Series (for resolver inputs), the SDC-19204 Series (for synchro inputs), or the SDC-14560 Series hybrid converters.

The converters feature jumper-programmable resolution (10, 12, 14 or 16 bits), programmable high or low bandwidth, and a high quality velocity output voltage (VEL). Output angle information is provided in two 8-bit bytes to the computer.

All information generated by the SDC-36015 is I/O mapped in four RAM locations and is available to the computer with a read command. This includes digital angle, 4-bits of turns

counting, Built-In-Test (BIT), and Loss-of-Signal (LOS) information for each channel.

Software that is available on request includes drivers in "C," Pascal, LabWindows, LabWindows/CVI, and LabVIEW.

### APPLICATIONS

Demonstration software, which shows the SDC-36015's capabilities, is available with the card. The multi-channel SDC-36015 is designed for use in test systems and high performance simulation and control systems. With programmable resolution and high accuracy, the SDC-36015 is an excellent choice for applications including motor control antenna positioning, CNC machine tooling, robot axis control and process control.

### FEATURES

- **Low Cost**
- **Accuracy to +1.3 Arc Minutes**
- **One to Six Channels**
- **Each Channel Offers:**
  - **Programmable Resolution and Bandwidth**
  - **High-Quality Velocity Output**
  - **BIT, LOS, and 4-BITS Turns Counting**

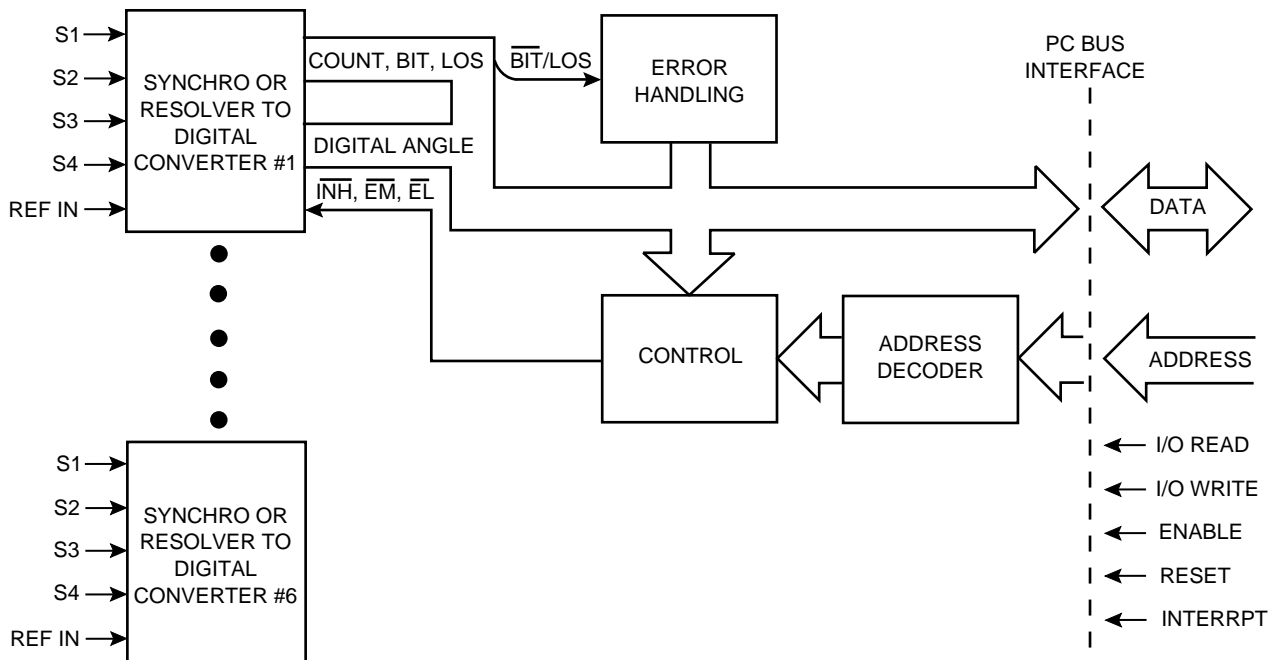

FIGURE 1. SDC-36015 BLOCK DIAGRAM

TABLE 1. SDC-36015 REQUIREMENTS AND CAPABILITIES		
<b>Hardware Requirements</b> IBM PC/XT/AT or compatible with 512K RAM DDCs SDC-36015 Card		
PARAMETER	UNITS	VALUE
<b>Power Supply</b> Current Drain	mA	950 max with six channels
<b>Temperature Range</b> Operating (Case)	°C	0 to +50
Storage	°C	-65 to +150
<b>Physical Characteristics</b> (Full Size IBM PC Card)	in (cm)	4.5 x 13.5 x 0.44 (11.4 x 34.3 x 1.1)
*Specifications for the RDC-19200 Series, SDC-19204, and SDC-14560 Series are detailed in individual data sheets.		

## SDC-36015 OPERATION

The SDC-36015 operation begins with the computer writing a Command Word to the card to setup for the desired function. The card then updates its information, storing it in its latches. The computer then retrieves the information during a read.

The Command Word is written to the card indicating the desired channel to get information from, and the condition of interrupt, Counter Reset, and Inhibit. The Command Word is shown in FIGURE 2 and its functions listed in TABLE 2.

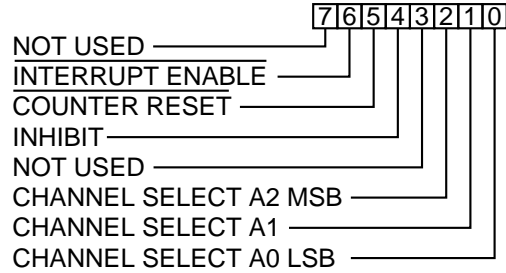

FIGURE 2. COMMAND WORD

## INTRODUCTION

The SDC-36015 is a full-size IBM PC card which accepts up to six channels of synchro or resolver signals. Resolution (10, 12, 14, or 16 bits) and bandwidth (high or low) is jumper programmable for each converter on the SDC-36015 card.

The synchro or resolver signals are converted to digital angle information which is then stored in latches and output to the computer during read cycles. Also available for each channel are turns counting, error status, and velocity (VEL) information. A block diagram of the SDC-36015 is shown in FIGURE 1. The circuit provides the following information from each channel to the computer over the data bus:

1. Digital angle data in two 8-bit bytes (LSB and MSB).
2. Turns count data along with status information (BIT and LOS).
3. An error map showing the status of all channels simultaneously.

The SDC-36015 receives commands from the computer to initiate the above tasks.

### Selection of SDC/RDC-1920X and SDC-1456X

Set jumper 7, "DS" (Device Select), to +5 V to select SDC/RDC-1920X; GND to select SDC-1456X.

## ADDRESSING REQUIREMENTS

The SDC-36015 card is preset at the factory to reside at address 300 HEX and 303 HEX. This location may be changed by moving the jumpers on the SDC-36015. Refer to TABLE 5 for jumper positioning.

TABLE 2. COMMAND WORD FUNCTIONS								
FUNCTION	D7	D6	D5	D4	D3	D2	D1	D0
CHANNEL 1 ENABLED	X	X	X	X	X	0	0	0
CHANNEL 2 ENABLED	X	X	X	X	X	0	0	1
CHANNEL 3 ENABLED	X	X	X	X	X	0	1	0
CHANNEL 4 ENABLED	X	X	X	X	X	0	1	1
CHANNEL 5 ENABLED	X	X	X	X	X	1	0	0
CHANNEL 6 ENABLED	X	X	X	X	X	1	0	1
INHIBIT ON	X	X	X	0	X	X	X	X
COUNTER RESET (TURNS)	X	X	1	X	X	X	X	X
INTERRUPT ENABLED	X	1	X	X	X	X	X	X
X=DON'T CARE								

### OUTPUT FUNCTION CODE SELECTION

After the Command Word is latched in memory and the desired function initialized, the SDC-36015 will output information to its data bus. The two LSBs of the Address Bus (A0 and A1) select which parameter is to be read. TABLE 3 lists the output function codes.

TABLE 3. OUTPUT FUNCTION CODES		
FUNCTION	A1	A0
8 LSBs of Angle	0	0
8 MSBs of Angle	0	1
Status/Count	1	0
Status/Error Map	1	1

### DECODING THE 8 LSBs AND 8 MSBs OF ANGLE

The resolver shaft angle is decoded from the combination of the LSB and MSB with the following formula:

$$\text{Shaft Angle} = 360 \cdot (\text{MSB} \cdot 256 + \text{LSB}) / 65536$$

where:

Shaft angle is in decimal degrees

LSB and MSB are the decimal equivalent of the two 8-bit bytes representing the angle.

For example:

If the following digital angle was output:

MSB 0 1 0 1 1 1 1 0

LSB 0 0 1 0 0 1 1 0

the decimal equivalent for the MSB is 94

and the decimal equivalent for the LSB is 38.

After inserting these values into equation:

$$\text{Shaft Angle} = 360 \cdot (94 \cdot 256 + 38) / 65536$$

$$\text{Shaft Angle} = 132.396$$

### STATUS/COUNT INFORMATION

FIGURE 3 shows the status and count information for the selected channel. Definitions of the bit functions follow.

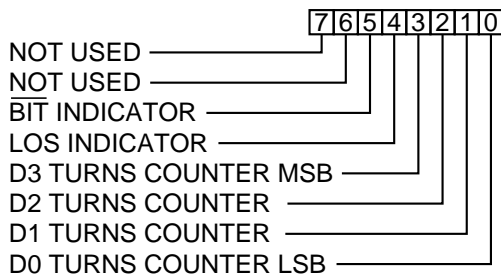

FIGURE 3. STATUS/COUNT WORD (EACH CHANNEL)

**LOS Indicator** - Loss-of-Signal Indicator. A logic 1 at this location indicates a loss of synchro or resolver signal to the converter.

**BIT Indicator** - Built-in-Test Indicator. A logic 0 at this location indicates the BIT fault flag has been raised. This occurs if the loop error signal in the converter exceeds a specified limit.

**Turns Count** - D0–D3. D0 is the LSB of a four bit word indicating turns count. The counter will increment/decrement at each complete revolution of the resolver or synchro shaft input.

### STATUS ERROR MAP

When a BIT or LOS is indicated by any converter, the Status Error Map (see FIGURE 4) is latched to store the status information at the precise time the error occurred. Interrupt line, IRQ3, is also latched low to indicate the fault to the computer. The interrupt handling routine should reset the interrupt flag using the interrupt enable lines as part of its function. A logic 1 at any position indicates that either a BIT or LOS has occurred.

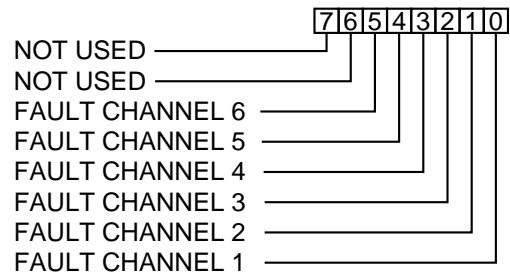

FIGURE 4. STATUS/COUNT ERROR MAP

### OPERATING THE SDC-36015 WITH LESS THAN SIX CHANNELS

If the SDC-36015 is to be used with less than all six channels, or, if it is required that a specific channel does not set the INTERRUPT line, then that/those channel(s) should have the interrupt function disabled.

To disable the INTERRUPT, use jumper switches E1 to E6 (for channels 1 to 6). The interrupt is disabled when the jumper is in the off position (the jumper position for ERR1 to ERR6 when set towards the top of the board turns the channel off and when set towards the bottom of the card turns the channel on). The BIT and LOS information going to the data bus and the STATUS ERROR MAP is not affected by the disable function.

### PROGRAMMABLE RESOLUTION AND BANDWIDTH

Each individual converter can be jumper programmed for either 10, 12, 14, or 16-bit resolution and low (130 Hz) or high (530 Hz) bandwidth.

**RESOLUTION:** The resolution for each channel is set by the A and B jumper switches as follows in TABLE 4:

TABLE 4. RESOLUTION PROGRAMMING		
B	A	RESOLUTION
0	0	10 bits
0	1	12 bits
1	0	14 bits
1	1	16 bits

0 = jumper in OFF position  
1 = jumper in ON position

**BANDWIDTH:** The BW jumper is set to 1 for high bandwidth (530 Hz) and set to 0 for low bandwidth (130 Hz).

**Switch position (BW, A, B):** For channels 1, 3, and 5 - the jumper position towards the top of the card is logic 1; for channels 2, 4, and 6 - the jumper position towards the bottom of the card is logic 1.

**TABLE 5. SDC-36015 ADDRESS JUMPERS**

JUMPER	ADDRESS	ON	OFF	FUNCTION
W9	A9	X		Decode 3rd LSB of HEX I/O address
W8	A8	X		Decode 3rd LSB of HEX I/O address
W7	A7		X	Decode 2nd LSB of HEX I/O address
W6	A6		X	Decode 2nd LSB of HEX I/O address
W5	A5		X	Decode 2nd LSB of HEX I/O address
W4	A4		X	Decode 2nd LSB of HEX I/O address
W3	A3		X	Decode 1st LSB of HEX I/O address
W2	A2		X	Decode 1st LSB of HEX I/O address
	A1			Decoded elsewhere, not programmable

### VELOCITY AND DYNAMIC CHARACTERISTICS

An analog voltage is generated by the converter proportional to the rate of change of the shaft angle, and is available at the SDC-36015's edge connector as the velocity (VEL) signal. The dynamic characteristics can be determined from the specific tables on the RDC-19200 and SDC-14560 data sheets.

The velocity output scale factor can be changed from nominal by inserting resistors R1, R8, R11, R18, R19, and R26 for channels 1 to 6, respectively. The individual converter's data sheet specifies the values of the resistors.

**Note: The velocity output scale factor can only be changed for the RDC-19200 Series and the SDC-19204/06 converters; it cannot be changed for the SDC-14560 Series converters.**

### SOFTWARE DEVELOPMENT

For a program in assembly and a clock speed of 4.77 MHz (standard IBM XT speed) it will take approximately 15 µsec to cycle the converter. If a memory refresh occurs during this period, the time will be extended; faster clock speed will reduce this time.

**ADDRESSING** The SDC-36015 is preset to reside from address 300H to 303H. These locations may be changed by repositioning the jumpers as shown in TABLE 5.

**Switch position for W2-W9:** The jumper position toward the top of the card is logic 0.

### SDC-36015 EDGE CONNECTOR

The SDC-36015's edge connector is wired as listed in TABLE 6.

**WARNING**

High voltages (reference and signal voltages) can be present on the SDC-36015 even if the PC power is turned off. Turn off all reference and input signal voltages, if possible, before installing the card in the PC to prevent accidental injury and/or damage to the card. Fasten the SDC-36015 to the PC before reapplying power.

**TABLE 6. SDC-36015 "D" TYPE 37-PIN CONNECTOR**

CHANNEL	1	2	3	4	5	6
S1	18	9	15	24	12	21
S2	37	27	34	6	31	3
S3	19	28	16	25	13	22
S4	30	10	35	7	32	4
VEL	29	8	36	5	33	2
REF IN	11	26	17	23	14	20
GND	1	1	1	1	1	1

**CAUTION**

Do not connect REF IN to GND; the reference is single-ended on the card, and GND is PC chassis ground. To prevent damage, RL has a fuse.

### TIMING REQUIREMENTS

The timing requirements of the converters (RDC-19200 or SDC-14560) are shown in FIGURES 5 through 7. The CPU I/O read-and-write timing of the IBM bus is shown in FIGURE 8.

When the Inhibit command is initiated there is a 500 nanosecond delay before data from the converter is valid. If the converter is in the middle of the updating its count, then a 400 to 700 nanosecond delay may also occur. As a result of these two delays, the converter's repetition rate for retrieving data cannot be faster than 1200 nanoseconds.

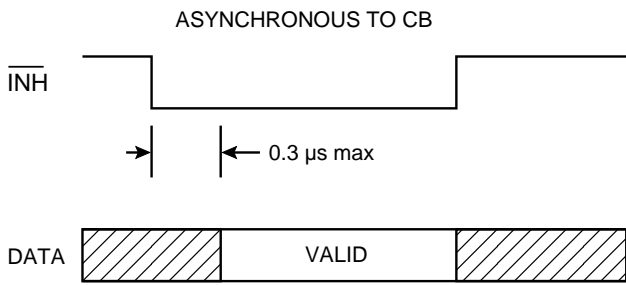

**FIGURE 5. INHIBIT TIMING**

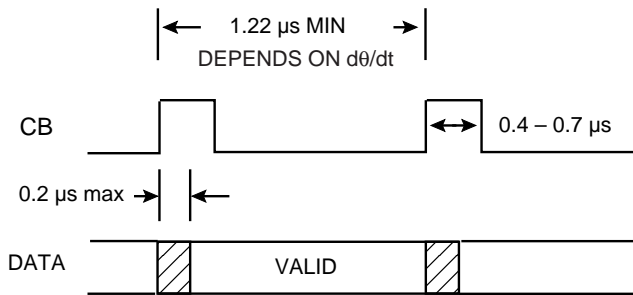

**FIGURE 6. CONVERTER BUSY TIMING**

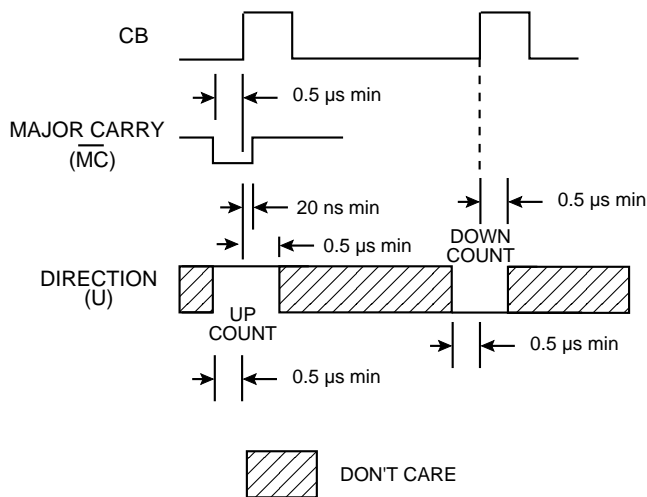

**FIGURE 7. INCREMENTAL AND TURNS COUNTING**

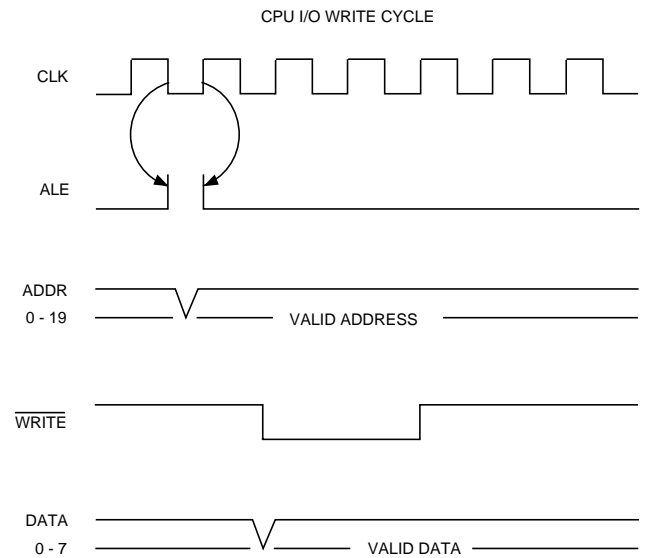
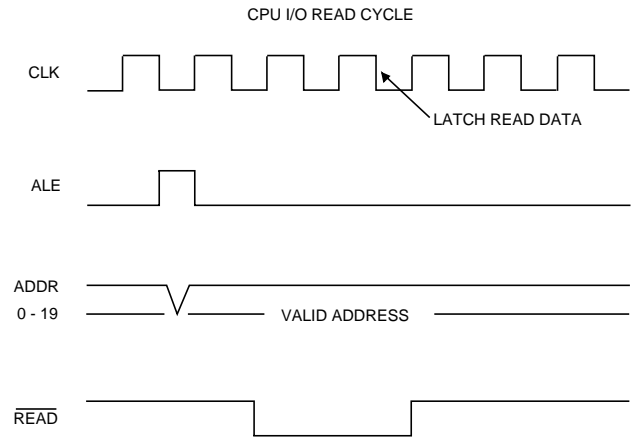

**FIGURE 8. CPU READ-AND-WRITE CYCLE**

## INTERFACE SPECIFICATIONS

The SDC-36015 inputs place one LS TTL load each of the IBM bus and uses one standard TTL signal level to drive it. See TABLE 7 for computer interface pin numbers and functions.

TABLE 7. SDC-36015 I/O INTERFACE PIN FUNCTIONS		
PIN	SIGNAL NAME	FUNCTION
A1	I/O Check	Not Used
A2	D7	Data Bit 7
A3	D6	Data Bit 6
A4	D5	Data Bit 5
A5	D4	Data Bit 4
A6	D3	Data Bit 3
A7	D2	Data Bit 2
A8	D1	Data Bit 1
A9	D0	Data Bit 0
A10	I/O Ready	Not Used
A11	AEN	Address Enable
A12	A19	Address Bit 19
A13	A18	Address Bit 18
A14	A17	Address Bit 17
A15	A16	Address Bit 16
A16	A15	Address Bit 15
A17	A14	Address Bit 14
A18	A13	Address Bit 13
A19	A12	Address Bit 12
A20	A11	Address Bit 11
A21	A10	Address Bit 10
A22	A9	Address Bit 9
A23	A8	Address Bit 8
A24	A7	Address Bit 7
A25	A6	Address Bit 6
A26	A5	Address Bit 5
A27	A4	Address Bit 4
A28	A3	Address Bit 3
A29	A2	Address Bit 2
A30	A1	Address Bit 1
A31	A0	Address Bit 0

TABLE 7. SDC-36015 I/O INTERFACE PIN FUNCTIONS (CONTINUED)		
PIN	SIGNAL NAME	FUNCTION
B1	Ground	Signal Ground
B2	Reset	System Reset
B3	+5V	Power Supply
B4	IRQ2	Not Used
B5	-5V	Power Supply
B6	DRQ2	Not Used
B7	-12V	Power Supply
B8	$\overline{OVS}$	Not Used
B9	+12V	Power Supply
B10	Ground	Ground
B11	$\overline{MEMW}$	Not Used
B12	$\overline{MEMR}$	Not Used
B13	$\overline{IOW}$	I/O Write
B14	$\overline{IOR}$	I/O Read
B15	$\overline{DACK3}$	Not Used
B16	DRQ3	Not Used
B17	$\overline{DACK1}$	Not Used
B18	DRQ1	Not Used
B19	DACK0	Not Used
B20	Clock	Not Used
B21	IRQ7	Not Used
B22	IRQ6	Not Used
B23	IRQ5	Not Used
B24	IRQ4	Not Used
B25	IRQ3	Interrupt 3
B26	$\overline{DACK2}$	Not Used
B27	T/C	Not Used
B28	ALE	Not Used
B29	+5V	Power Supply
B30	OSC	Not Used
B31	Ground	Signal Ground

SDC-36015 ORDERING SUPPLEMENT

CONFIGURATION INFORMATION

COMPANY NAME: \_\_\_\_\_ CONTACT: \_\_\_\_\_

LOCATION: \_\_\_\_\_

PHONE #: \_\_\_\_\_ FAX #: \_\_\_\_\_

P.O. #: \_\_\_\_\_ DATE: \_\_\_\_\_

CHANNEL 1 CONVERTER P/N: \_\_\_\_\_
RESOLUTION: 10 12 14 16 BIT (Circle One)
BANDWIDTH: HIGH LOW (Circle One)

CHANNEL 2 CONVERTER P/N: \_\_\_\_\_
RESOLUTION: 10 12 14 16 BIT (Circle One)
BANDWIDTH: HIGH LOW (Circle One)

CHANNEL 3 CONVERTER P/N: \_\_\_\_\_
RESOLUTION: 10 12 14 16 BIT (Circle One)
BANDWIDTH: HIGH LOW (Circle One)

CHANNEL 4 CONVERTER P/N: \_\_\_\_\_
RESOLUTION: 10 12 14 16 BIT (Circle One)
BANDWIDTH: HIGH LOW (Circle One)

CHANNEL 5 CONVERTER P/N: \_\_\_\_\_
RESOLUTION: 10 12 14 16 BIT (Circle One)
BANDWIDTH: HIGH LOW (Circle One)

CHANNEL 6 CONVERTER P/N: \_\_\_\_\_
RESOLUTION: 10 12 14 16 BIT (Circle One)
BANDWIDTH: HIGH LOW (Circle One)

CARD S/N: \_\_\_\_\_

- NOTES: 1) PLEASE ENTER COMPLETE PART NUMBERS IN THE CHANNELS YOU WISH TO POPULATE.
2) EACH CHANNEL CAN ACCOMODATE EITHER RDC-19200, SDC-19204/6, OR SDC-14560 SERIES CONVERTERS IN ANY POSITION. YOU CANNOT MIX SDC-14560 SERIES WITH RDC-19200 AND SDC-19204/6 CONVERTERS ON THE SAME CARD.
3) IF WE DO NOT RECEIVE THIS INFORMATION, ALL CONVERTERS WILL BE SET TO 16 BIT, LOW BANDWIDTH AND INSERTED STARTING WITH CHANNEL #1.

PLEASE RETURN THIS FORM TO SALES REP. OR FAX TO DDC.
ATTN: CUSTOMER SERVICE
TOLL FREE #: 1-800-332-5757
FAX #: (631) 567-7358

CC: CUSTOMER SERVICE S.O. FILE FINISHED GOODS
DISCRETE PRODUCTION CONTROL S.O.# \_\_\_\_\_





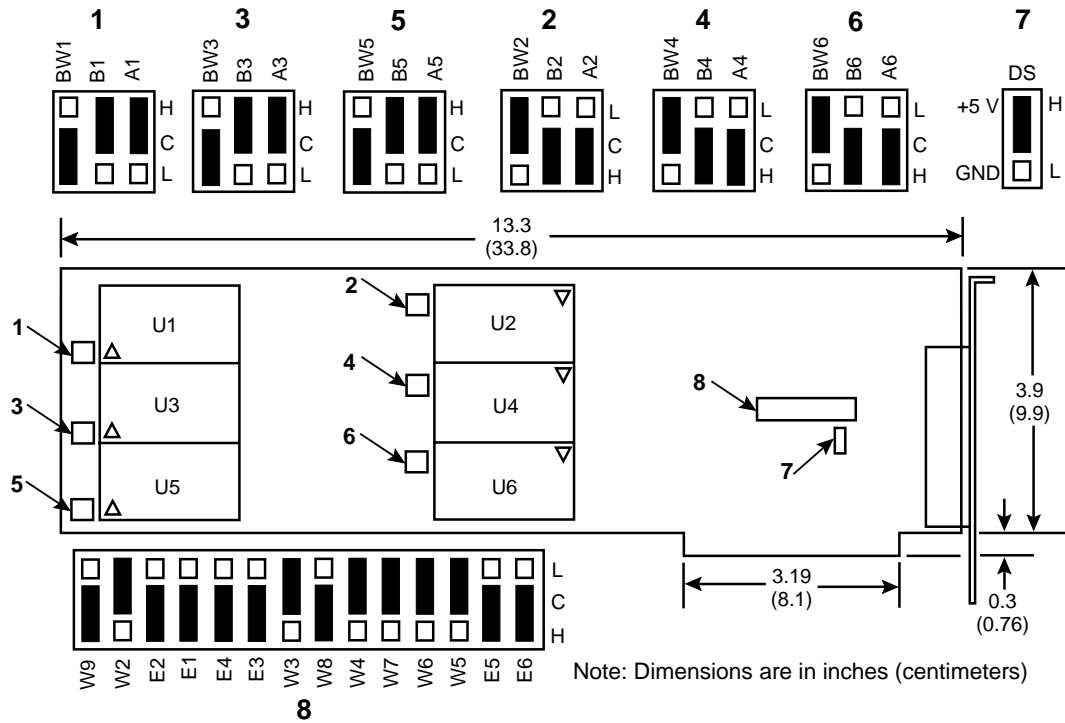

**CAUTION:**  
 When installing the converters, they must be oriented correctly. Channels 1(U1), 3(U3), and 5(U5) must be installed with pin 1 in the lower left corner. Channels 2(U2), 4(U4), and 6(U6) must be installed with pin 1 in the upper right corner.

**FIGURE 9. SDC-36015 MECHANICAL OUTLINE**

## ORDERING INFORMATION

**Card Assembly:** SDC-36015 (See Notes 1, 2, and 3)

### CONVERTERS

RDC-1920X-30X

**Accuracy (Note 4):**

- 1 = 8 minutes + 1 LSB (Note 6)  
(12 LSB's Differential Linearity)
- 2 = 4 minutes + 1 LSB (Note 5)  
(8 LSB's Differential Linearity)
- 3 = 3 minutes + 1 LSB  
(4 LSB's Differential Linearity)
- 4 = 2 minutes + 1 LSB (Note 6)  
(4 LSB's Differential Linearity)

**Configuration:**

- 0 = 11.8 V, 2% Linearity
- 2 = 2 V, 2% Linearity

SDC-1920X-30X

**Accuracy (Note 4):**

- 1 = 8 minutes + 1 LSB  
(12 LSBs Differential Linearity)
- 2 = 4 minutes + 1 LSB  
(8 LSBs Differential Linearity)
- 3 = 3 minutes + 1 LSB  
(4 LSBs Differential Linearity)
- 4 = 2 minutes + 1 LSB  
(4 LSBs Differential Linearity)

**Configuration:**

- 4 = 11.8 V, 2% Linearity
- 6 = 90 V, 2% Linearity

#### Notes:

1. The SDC-36015 is a standard, full-sized IBM PC/XT/AT card (4.5 x 13.5 x 0.44 inches).
2. Converters are ordered separately as listed above and installed by the user. Sockets are included with the SDC-36015. (DDC can install and test complete cards if a configuration sheet accompanies the order.)
3. The SDC-14560 Series of hybrid converters can be used if higher accuracies are required. (Consult factory.)
4. Differential linearity is multiplied by the LSB in the 16th bit.
5. Vel and e are not characterized on model RDC-19202-300.
6. Available for RDC-19202 only.

# NOTES

The information provided in this data sheet is believed to be accurate; however, no responsibility is assumed by Data Device Corporation for its use, and no license or rights are granted by implication or otherwise in connection therewith.  
Specifications are subject to change without notice.



105 Wilbur Place, Bohemia, New York 11716-2482

**For Technical Support - 1-800-DDC-5757 ext. 7389 or 7413**

**Headquarters** - Tel: (631) 567-5600 ext. 7389 or 7413, Fax: (631) 567-7358

**Southeast** - Tel: (703) 450-7900, Fax: (703) 450-6610

**West Coast** - Tel: (714) 895-9777, Fax: (714) 895-4988

**Europe** - Tel: +44-(0)1635-811140, Fax: +44-(0)1635-32264

**Asia/Pacific** - Tel: +81-(0)3-3814-7688, Fax: +81-(0)3-3814-7689

**World Wide Web** - <http://www.ddc-web.com>



ILC DATA DEVICE CORPORATION  
REGISTERED TO ISO 9001  
FILE NO. A5976