

## N-Channel Enhancement Mode Power MOSFET

### Description

The RM100N60DF uses advanced trench technology and design to provide excellent  $R_{DS(ON)}$  with low gate charge. It can be used in a wide variety of applications.

### General Feature

- $V_{DS} = 65V, I_D = 95A$   
 $R_{DS(ON)} < 4.6m\Omega @ V_{GS}=10V$  (Typ:3.8m $\Omega$ )  
 $R_{DS(ON)} < 7m\Omega @ V_{GS}=4.5V$  (Typ:5.6m $\Omega$ )
- Special process technology for high ESD capability
- High density cell design for ultra low Rdson
- Fully characterized Avalanche voltage and current
- Good stability and uniformity with high  $E_{AS}$
- Excellent package for good heat dissipation

### Application

- Power switching application
- Hard switched and high frequency circuits
- Uninterruptible power supply
- Halogen-free

**100% UIS TESTED!**

**100%  $\Delta V_{ds}$  TESTED!**

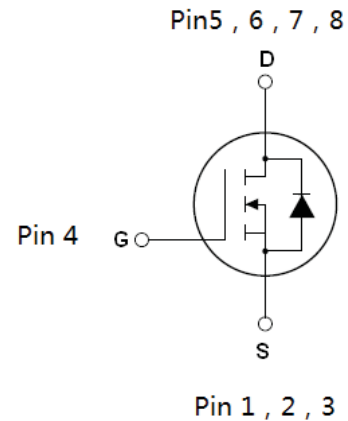

**Schematic diagram**

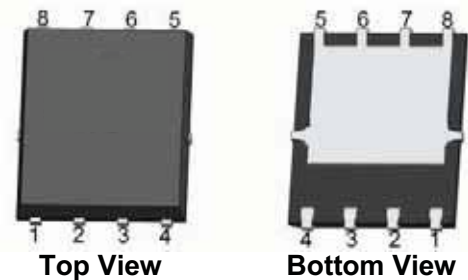

**Top View**

**Bottom View**

### Package Marking and Ordering Information

Device Marking	Device	Device Package	Reel Size	Tape width	Quantity
AN60	RM100N60DF	DFN5X6-8L	-	-	-

### Absolute Maximum Ratings ( $T_C=25^\circ C$ unless otherwise noted)

Parameter	Symbol	Conditions	Value	Unit
Continuous Drain Current (Silicon Limited)	$I_D$	$T_C=25^\circ C$	95	A
		$T_C=100^\circ C$	60	
		$T_C=25^\circ C$	45	
Continuous Drain Current (Package Limited)				
Drain to Source Voltage	$V_{DS}$	-	65	V
Gate to Source Voltage	$V_{GS}$	-	$\pm 20$	V
Pulsed Drain Current	$I_{DM}$	-	340	A
Avalanche Energy, Single Pulse	$E_{AS}$	$L=0.1mH, T_C=25^\circ C$	31	mJ
Power Dissipation	$P_D$	$T_C=25^\circ C$	74	W
Operating and Storage Temperature	$T_J, T_{stg}$	-	-55 to 150	$^\circ C$

## Absolute Maximum Ratings

Parameter	Symbol	Max	Unit
Thermal Resistance Junction-Ambient	$R_{\theta JA}$	50	$^{\circ}\text{C}/\text{W}$
Thermal Resistance Junction-Case	$R_{\theta JC}$	1.7	$^{\circ}\text{C}/\text{W}$

## Electrical Characteristics ( $T_C=25^{\circ}\text{C}$ unless otherwise noted)

Parameter	Symbol	Conditions	Value			Unit
			min	typ	max	
Drain to Source Breakdown Voltage	$V_{(BR)DSS}$	$V_{GS}=0\text{V}, I_D=250\mu\text{A}$	65	-	-	V
Gate Threshold Voltage	$V_{GS(th)}$	$V_{GS}=V_{DS}, I_D=250\mu\text{A}$	1.0	1.6	2.4	
Zero Gate Voltage Drain Current	$I_{DSS}$	$V_{GS}=0\text{V}, V_{DS}=60\text{V}, T_J=25^{\circ}\text{C}$	-	-	1	$\mu\text{A}$
		$V_{GS}=0\text{V}, V_{DS}=60\text{V}, T_J=100^{\circ}\text{C}$	-	-	100	
Gate to Source Leakage Current	$I_{GSS}$	$V_{GS}=\pm 20\text{V}, V_{DS}=0\text{V}$	-	-	$\pm 100$	nA
Drain to Source on Resistance	$R_{DS(on)}$	$V_{GS}=10\text{V}, I_D=20\text{A}$	-	3.8	4.6	$\text{m}\Omega$
Drain to Source on Resistance	$R_{DS(on)}$	$V_{GS}=4.5\text{V}, I_D=10\text{A}$	-	5.6	7	$\text{m}\Omega$
Transconductance	$g_{fs}$	$V_{DS}=5\text{V}, I_D=20\text{A}$	-	60	-	S
Gate Resistance	$R_G$	$V_{GS}=0\text{V}, V_{DS}$ Open, $f=1\text{MHz}$	-	1.3	-	$\Omega$

## Dynamic Characteristics

Input Capacitance	$C_{iss}$	$V_{GS}=0\text{V}, V_{DS}=30\text{V}, f=1\text{MHz}$	-	1978	-	pF
Output Capacitance	$C_{oss}$		-	870	-	
Reverse Transfer Capacitance	$C_{rss}$		-	56	-	
Total Gate Charge	$Q_g(10\text{V})$	$V_{DD}=30\text{V}, I_D=20\text{A}, V_{GS}=10\text{V}$	-	41	-	nC
Total Gate Charge	$Q_g(4.5\text{V})$		-	25	-	
Gate to Source Charge	$Q_{gs}$		-	5	-	
Gate to Drain (Miller) Charge	$Q_{gd}$		-	11	-	
Turn on Delay Time	$t_{d(on)}$	$V_{DD}=30\text{V}, I_D=20\text{A}, V_{GS}=10\text{V}, R_G=10\Omega,$	-	10	-	ns
Rise time	$t_r$		-	8	-	
Turn off Delay Time	$t_{d(off)}$		-	34	-	
Fall Time	$t_f$		-	10	-	

## Reverse Diode Characteristics

Diode Forward Voltage	$V_{SD}$	$V_{GS}=0\text{V}, I_F=30\text{A}$	-	0.9	1.2	V
Reverse Recovery Time	$t_{rr}$	$V_R=30\text{V}, I_F=20\text{A}, dI_F/dt=400\text{A}/\mu\text{s}$	-	30	-	ns
Reverse Recovery Charge	$Q_{rr}$		-	68	-	nC

# RATING AND CHARACTERISTICS CURVES (RM100N60DF)

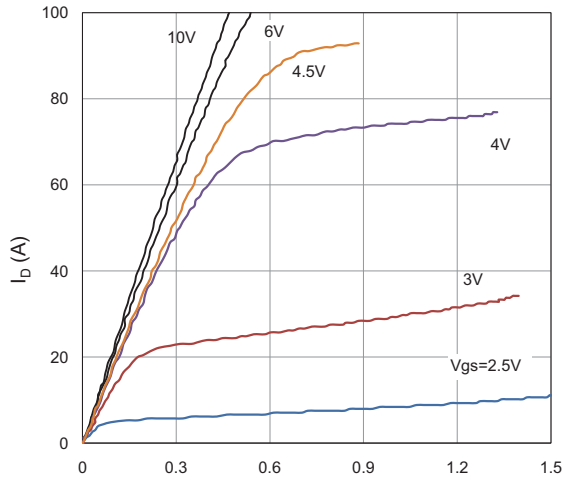

Fig 1. Typical Output Characteristics

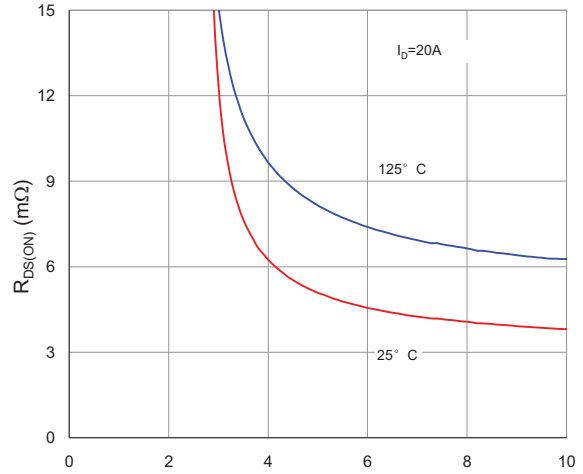

Figure 2. On-Resistance vs. Gate-Source Voltage

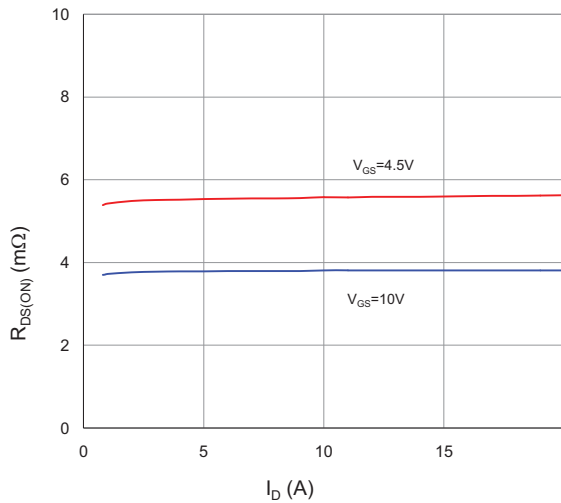

Figure 3. On-Resistance vs. Drain Current and Gate Voltage

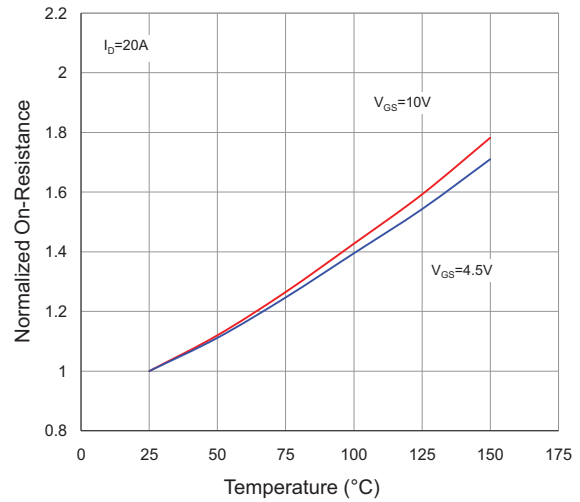

Figure 4. Normalized On-Resistance vs. Junction Temperature

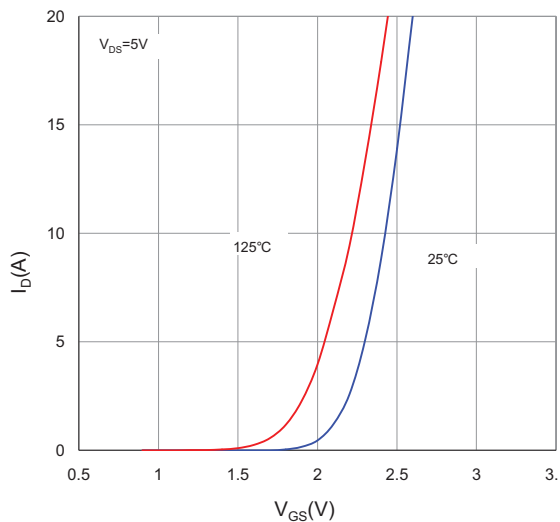

Figure 5. Typical Transfer Characteristics

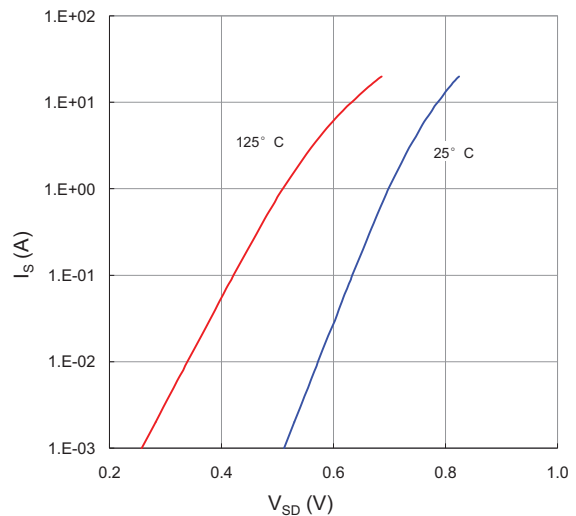

Figure 6. Typical Source-Drain Diode Forward Voltage

# RATING AND CHARACTERISTICS CURVES (RM100N60DF)

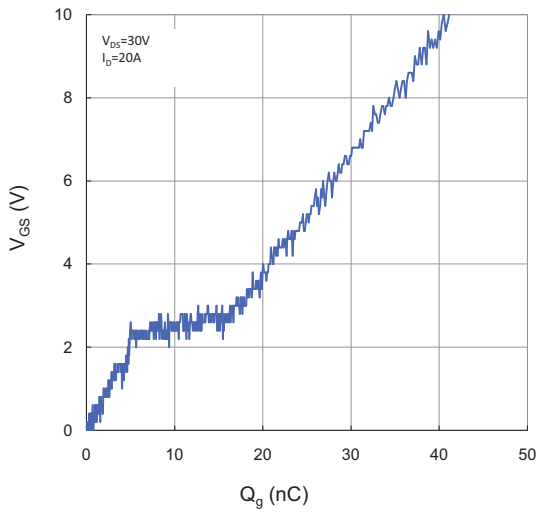

Figure 7. Typical Gate-Charge vs. Gate-to-Source Voltage

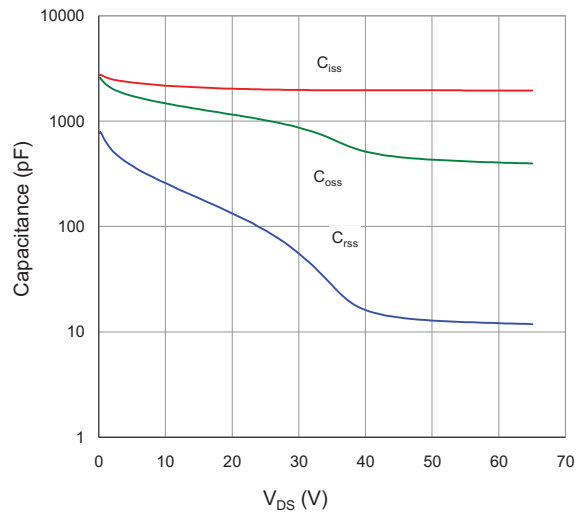

Figure 8. Typical Capacitance vs. Drain-to-Source Voltage

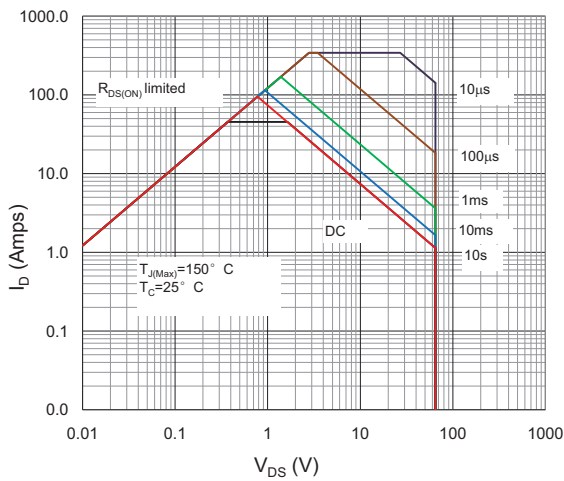

Figure 9. Maximum Safe Operating Area

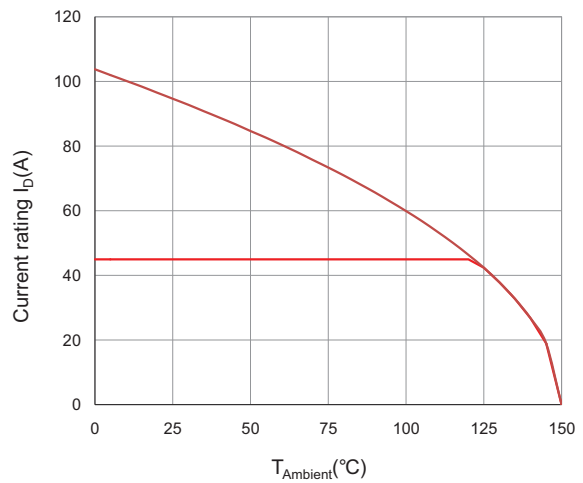

Figure 10. Maximum Drain Current vs. Case Temperature

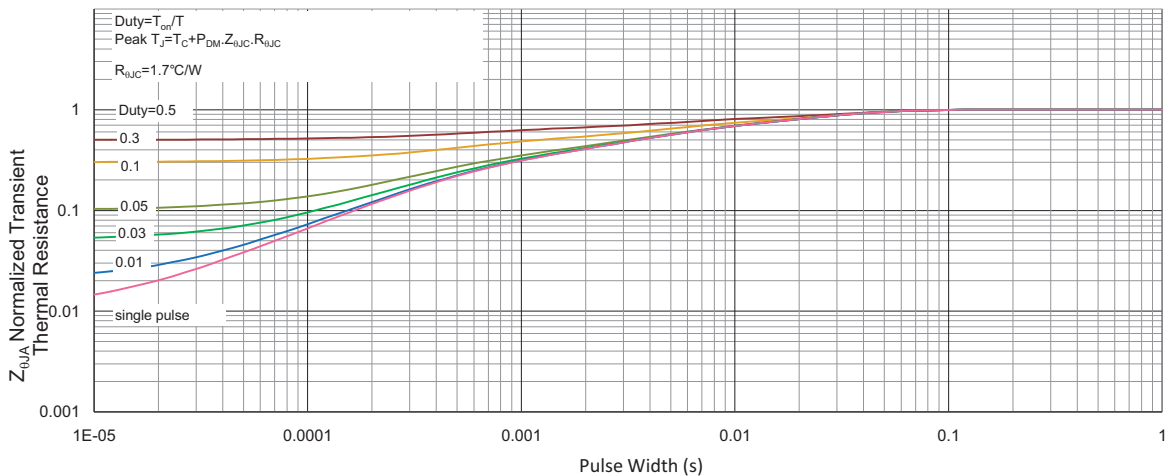

Figure 11. Normalized Maximum Transient Thermal Impedance, Junction-to-Ambient



## DISCLAIMER NOTICE

Rectron Inc reserves the right to make changes without notice to any product specification herein, to make corrections, modifications, enhancements or other changes. Rectron Inc or anyone on its behalf assumes no responsibility or liability for any errors or inaccuracies. Data sheet specifications and its information contained are intended to provide a product description only. "Typical" parameters which may be included on RECTRON data sheets and/ or specifications can and do vary in different applications and actual performance may vary over time. Rectron Inc does not assume any liability arising out of the application or use of any product or circuit.

Rectron products are not designed, intended or authorized for use in medical, life-saving implant or other applications intended for life-sustaining or other related applications where a failure or malfunction of component or circuitry may directly or indirectly cause injury or threaten a life without expressed written approval of Rectron Inc. Customers using or selling Rectron components for use in such applications do so at their own risk and shall agree to fully indemnify Rectron Inc and its subsidiaries harmless against all claims, damages and expenditures.