

Silicon N Channel MOS FET Triode

BF 543

Preliminary Data

- For RF stages up to 300 MHz preferably in FM applications
- $I_{DSS} = 4 \text{ mA}$, $g_{fs} = 12 \text{ mS}$

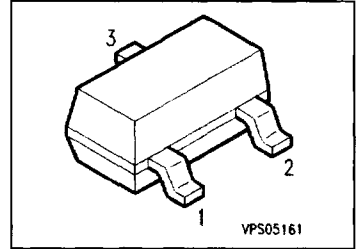

ESD: Electrostatic discharge sensitive device, observe handling precautions!

Type	Marking	Ordering Code (tape and reel)	Pin Configuration			Package ¹⁾
			1	2	3	
BF 543	LDs	Q62702-F1372	G	D	S	SOT-23

Maximum Ratings

Parameter	Symbol	Values	Unit
Drain-source voltage	V_{DS}	20	V
Drain current	I_D	30	mA
Gate-source peak current	$\pm I_{GSM}$	10	
Total power dissipation, $T_A \leq 60 \text{ }^\circ\text{C}$	P_{tot}	200	mW
Storage temperature range	T_{stg}	- 55 ... + 150	$^\circ\text{C}$
Channel temperature	T_{ch}	150	
Ambient temperature range	T_A	- 55 ... + 150	

Thermal Resistance

Junction - ambient ²⁾	$R_{th,JA}$	≤ 450	K/W
----------------------------------	-------------	------------	-----

1) For detailed information see chapter Package Outlines.

2) Package mounted on alumina 15 mm x 16.7 mm x 0.7 mm.

Electrical Characteristics

at $T_A = 25\text{ }^\circ\text{C}$, unless otherwise specified.

Parameter	Symbol	Values			Unit
		min.	typ.	max.	

DC Characteristics

Drain-source breakdown voltage $I_D = 10\text{ }\mu\text{A}$, $-V_{GS} = 4\text{ V}$	$V_{(BR)DS}$	20	–	–	V
Gate-source breakdown voltage $\pm I_{GS} = 10\text{ mA}$, $V_{DS} = 0$	$\pm V_{(BR)GSS}$	7	–	12	
Gate cutoff current $\pm V_{GS} = 6\text{ V}$, $V_{DS} = 0$	$\pm I_{GSS}$	–	–	50	nA
Drain current $V_{DS} = 10\text{ V}$, $V_{GS} = 0$	I_{DSS}	2.0	4	6.0	mA
Gate-source pinch-off voltage $V_{DS} = 10\text{ V}$, $I_D = 20\text{ }\mu\text{A}$	$-V_{GS(p)}$	–	0.7	1.5	V

AC Characteristics

Forward transconductance $V_{DS} = 10\text{ V}$, $I_D = 4\text{ mA}$, $f = 1\text{ kHz}$	g_{fs}	9.5	12	–	mS
Gate-1 input capacitance $V_{DS} = 10\text{ V}$, $I_D = 4\text{ mA}$, $f = 1\text{ MHz}$	C_{gss}	–	2.7	–	pF
Reverse transfer capacitance $V_{DS} = 10\text{ V}$, $I_D = 4\text{ mA}$, $f = 1\text{ MHz}$	C_{dg}	–	18	–	fF
Output capacitance $V_{DS} = 10\text{ V}$, $I_D = 4\text{ mA}$, $f = 1\text{ MHz}$	C_{dss}	–	0.9	–	pF
Power gain (test circuit) $V_{DS} = 10\text{ V}$, $I_D = 4\text{ mA}$, $f = 200\text{ MHz}$ $G_G = 2\text{ mS}$, $G_L = 0.5\text{ mS}$	G_p	–	22	–	dB
Noise figure (test circuit) $V_{DS} = 10\text{ V}$, $I_D = 4\text{ mA}$, $f = 200\text{ MHz}$ $G_G = 2\text{ mS}$, $G_L = 0.5\text{ mS}$	F	–	1	–	

Total power dissipation $P_{tot} = f(T_A)$

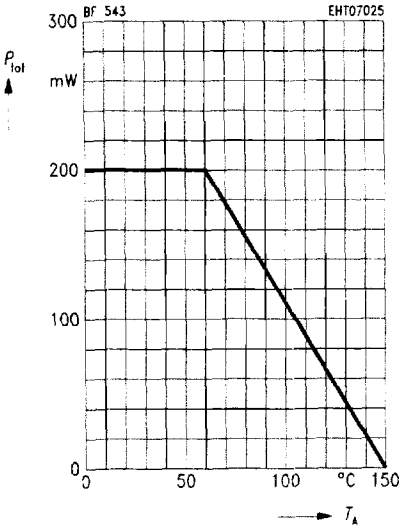

Typ. output characteristics $I_D = f(V_{DS})$

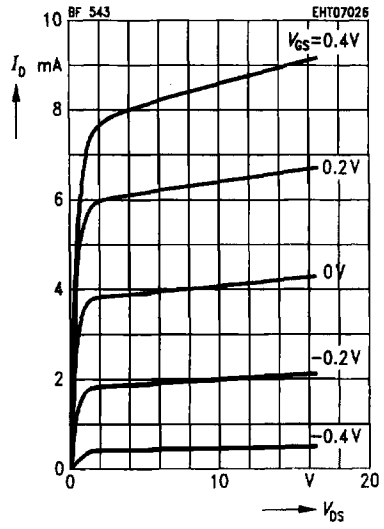

Gate transconductance $g_{fs} = f(V_{GS})$

$V_{DS} = 10V, I_{DSS} = 4mA, f = 1kHz$

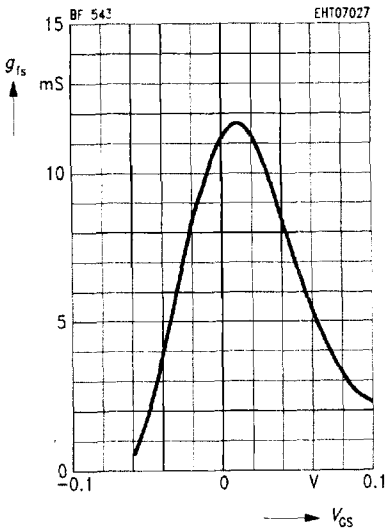

Drain current $I_D = f(V_{GS})$

$V_{DS} = 10V$

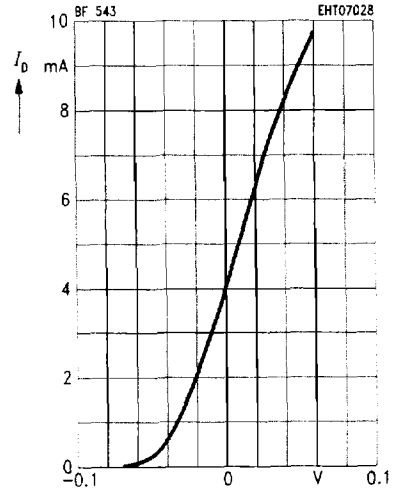

Gate input capacitance $C_{gss} = f(V_{GS})$

$V_{DS} = 10\text{ V}$, $I_{DSS} = 4\text{ mA}$, $f = 1\text{ MHz}$

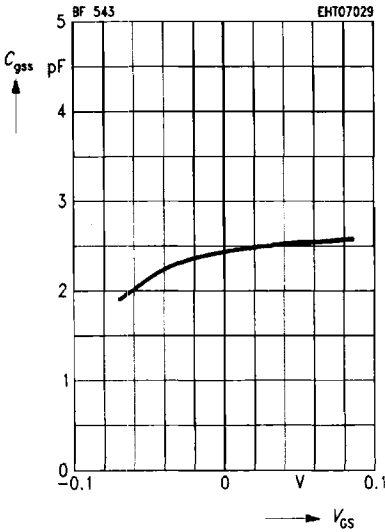

Output capacitance $C_{dss} = f(V_{DS})$

$V_{GS} = 0$, $I_{DSS} = 4\text{ mA}$, $f = 1\text{ MHz}$

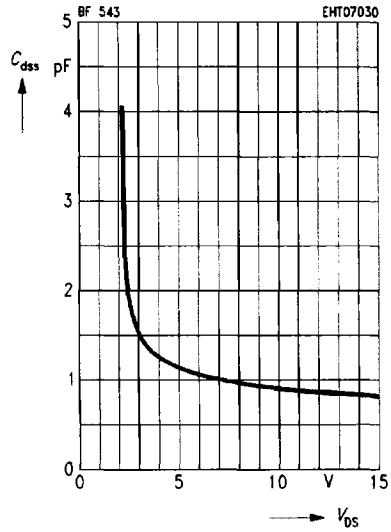

Reverse transfer capacitance

$C_{dg} = f(V_{DS})$

$V_{GS} = 0$, $I_{DSS} = 4\text{ mA}$, $f = 1\text{ MHz}$

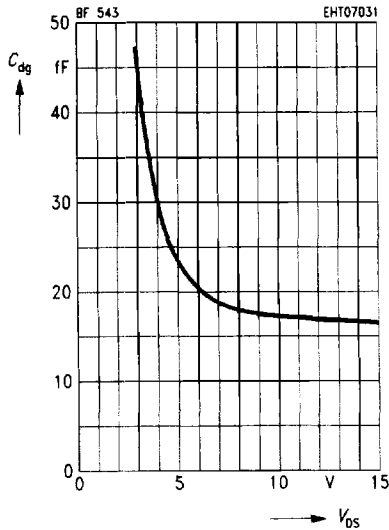

Gate 1 input admittance y_{11s}

$V_{DS} = 10\text{ V}$, $I_{DSS} = 4\text{ mA}$, $V_{GS} = 0$

(source circuit)

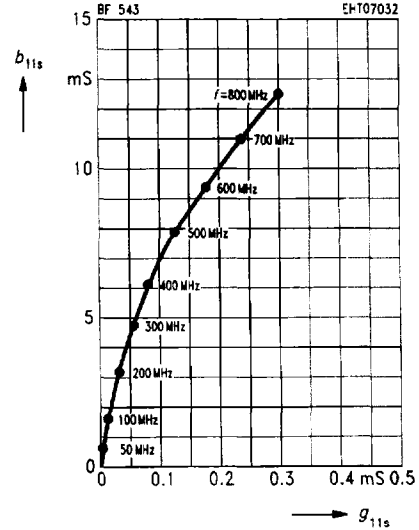

Gate 1 transconductance y_{21s}

$V_{DS} = 10\text{ V}$, $I_{DSS} = 4\text{ mA}$, $V_{GS} = 0$
(source circuit)

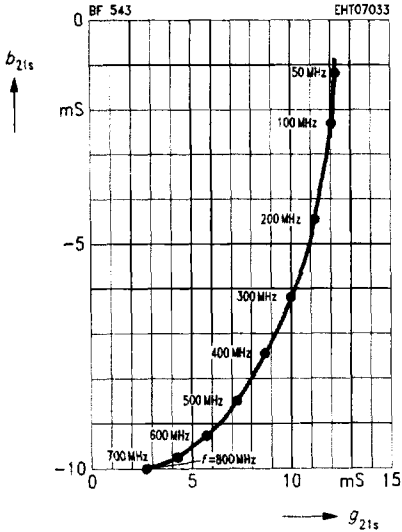

Output admittance y_{22s}

$V_{DS} = 10\text{ V}$, $I_{DSS} = 10\text{ mA}$, $V_{GS} = 0$
(source circuit)

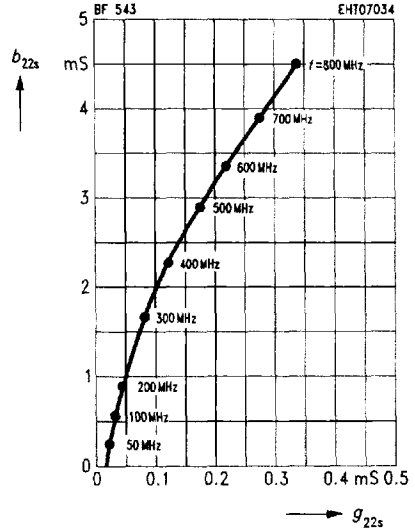

Test circuit for power gain G_p and noise figure F

$f = 200\text{ MHz}$, $G_G = 2\text{ mS}$, $G_L = 0.5\text{ mS}$

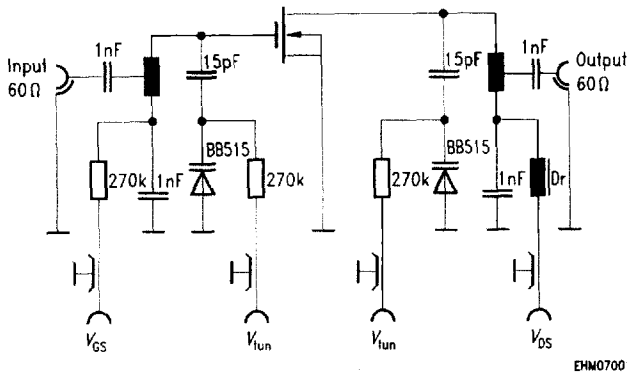

EHM07001