

MA31750

HIGH PERFORMANCE MIL-STD-1750 MICROPROCESSOR

The GEC Plessey MA31750 is a single-chip microprocessor that implements the full MIL-STD-1750A instruction set architecture, or Option 2 of Draft MIL-STD-1750B. The processor executes all mandatory instructions and many optional features are also included. Interrupts, fault handling, memory expansion, Console, timers A and B, and their related optional instructions are also supported in full accordance with MIL-STD-1750.

The MA31750 offers a considerable performance increase over the existing MAS281. This is achieved by using a 32-bit internal bus structure with a 24 x 24 bit multiplier and 32-bit ALU. Other performance-enhancing features include a 32-bit shift network, a multi-port register file and a dedicated address calculation unit.

The MA31750 has on-chip parity generation and checking to enhance system integrity. A comprehensive built-in self-test has also been incorporated, allowing processor functionality to be verified at any time.

Console operation is supported through a parallel interface using command/data registers in I/O space. Several discrete output signals are produced to minimise external logic.

Control signals are also provided to allow inclusion of the MA31750 into a multiprocessor or DMA system.

The processor can directly access 64KWords of memory in full accordance with MIL-STD-1750A. This increases to 1MWord when used with the optional MA31751 memory management unit (MMU). 1750B mode allows the system to be expanded to 8MWord with the MMU.

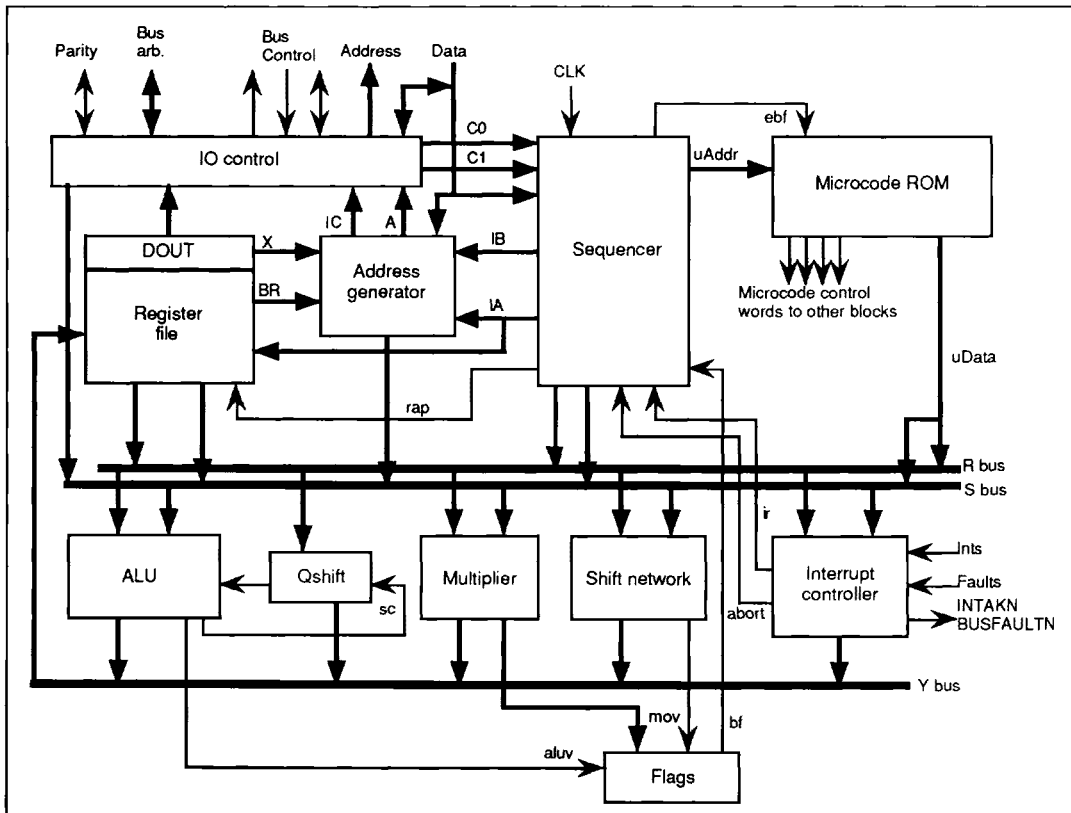

Figure 1: Architecture

MA31750

1. ARCHITECTURE

The GEC Plessey MA31750 Microprocessor is a high performance implementation of the MIL-STD-1750A (Notice 1) Instruction Set Architecture. Figure 1 depicts the architectural details of the chip. Two key features of this architecture which contribute to the overall high performance of the MA31750 are a 32-bit shift network and a 24-bit parallel multiplier. These sub-systems allow the MA31750 to perform multi-bit shifts, multiplications, divisions and normalisations in a fraction of the clock cycles required on machines not having such resources. This is especially true of floating-point operations, in which the MA31750 excels. Such operations constitute a large proportion of the Digital Avionics Instruction Set (DAIS) mix and generally a high percentage of many signal processing algorithms, therefore having a significant impact on system performance.

Key features include:

- 1) A three-bus (R, S, and Y) datapath consisting of an arithmetic/logic unit (ALU), three-port register file, shift network, parallel multiplier and flags block;
- 2) Four instruction fetch registers C0, C1, IA, and IB;
- 3) Two operand transfer registers DI, and DO;
- 4) Two address registers IC and A;
- 5) A state sequencer;
- 6) Micro-instruction decode logic.

The relationship between these functional blocks is shown in Figure 1.

2. ADDITIONAL FEATURES

The MA31750 may be operated in one of two basic user selectable modes. 1750A mode follows the requirements of MIL-STD-1750A (Notice 1) and implements all of the mandatory features of this standard. In addition, many of the optional features such as interval timers A and B, a watchdog timer and parity checking are included. 1750B mode, when selected, allows the user access to a range of new instructions and features as described in the Draft MIL-STD-1750B, Option 2. These include a range of unsigned arithmetic operations and expanded addressing support instructions.

2.1. MIL-STD-1750 OPTIONAL FEATURES

In addition to implementing all of the required features of MIL-STD-1750A and the Draft standard MIL-STD-1750B, the MA31750 also incorporates a number of optional features. Interval timers A and B as well as a trigger-go counter are provided. Most specified XIO commands are decoded directly on the chip and an additional set of commands, associated with MMU and BPU operations, are also decoded on chip.

2.2. BUS ARBITRATION

The MA31750 has a number of extra control lines to allow its use in a system utilising multiple processors. A bus request and grant system coupled with external arbitration logic allows common data and address buses to be used between devices. A lock request pin is also provided to allow the processor to maintain control of the buses when modifying areas of shared memory.

2.3. MEMORY BLOCK PROTECTION

The basic MMU function allows write or execute protection to be applied on 4kWord block boundaries. This may be further resolved to 1kWord blocks by the inclusion of a Block Protect Unit (BPU). The MA31751 can act as both an MMU and a BPU in 1750A mode, operating with the full compliment of 1MWord of memory. It will also support expansion to 8MWord in accordance with Draft MIL-STD-1750B.

3. MODES OF OPERATION

MA31750 operating modes include: (1) initialisation, (2) instruction execution, (3) interrupt servicing, (4) fault servicing, (5) timer operations and (6) console operation.

3.1. INITIALISATION

The MA31750 executes a microcoded initialisation routine in response to a hardware reset or power-up. Figure 3 shows a cycle-by-cycle breakdown of this routine. The operations performed are dependent on the system configuration read by the processor during startup. Figure 2 summarises the resulting initialisation state.

MA31750	
Instruction Counter	Zero
Status Word	Zero
Fault Register Zero	Zero
Fault Mask Register (1750B)	All ones
Pending Interrupt Register	Zero
Interrupt Mask Register	Zero
General Registers	Undefined
Interrupts	Disabled
Timers A and B	Zeroed and started
Timer Reset Registers (1750B)	Zero
Trigger-Go Counter	Reset and started
TGON Line	High
Start-Up ROM	Enabled
DMA	Disabled
MMU	
Page Registers AL/W/E fields	Zero
Page Register PPA field	Logical to physical
BPU	
Memory Protect RAM	Zero (disabled)
Global Memory Protect	Enabled

Figure 2: Initialization State

The last action performed by the initialisation routine is to load the instruction pipeline. Instruction fetches start at memory location zero with AS = 0, PS = 0 and PB = 0 and will be from the Start-Up ROM (SUR) if implemented. Whether BIT passes or not, the processor will begin instruction execution at this point. The system start-up code may include a routine to enable and unmask interrupts in order to detect and respond to a BIT failure if required.

Addr	Operation
0	PIC initialised
1	A ← 0x8410
*2	Read external configuration register from 8410H (CONFVN asserted low)
3	-
1F	-
20	If BPU, N ← 128 else N ← 0
21	Decrement N; branch to 21 if N ≥ 0
4	Write internal configuration register
5	-
6	If no MMU, br to 7
13	-
14	-
15	N ← 256
16	Decrement N
*17	Write MMU Instruction Page Register N
*18	Write MMU Operand Page Register N; branch to 16 if N > 0
19	A ← 0400H
1A	N ← 16
1B	PBSR ← N
1C	-
*1D	Write Memory control register to MMU with PB = N
1E	Decrement N; branch if N ≥ 0 to 1B
7	A ← 0
8	IC ← A
9	Br to BIT if required
A	-
B	Br if no SUR to 00D
C	-
D	Re-init PIC
E	-
F	Zero SW
10	-
32	-
33	Br to 011 if BIT passed (or not run)
34	
35	
36	Set FT bit 13
11	Init DMAE, SUREN, NPU
12	
*3F8	Fetch first word from 0
*3F9	Fetch second word from 1 First instruction first cycle

* Indicates an external cycle

Figure 3: Initialization Sequence

MA31750

3.1.1. CONFIGURATION REGISTER

The system configuration register allows the MA31750 to function with a variety of different system designs. Implemented features such as a BPU should be indicated as present by setting bits in an externally-implemented 16-bit latch - see figure 4 for bit assignments. The latch must be placed in IO space at the address defined by XIO RCW (8410) shown in the table of XIO commands, Figure 20c. The processor decodes this command internally and produces a discrete output signal CONFWN which may be used as the external register Output Enable control.

Bit	Function
0	MMU Select 0
1	BPU Select 0
2	1 = Console operation enabled
3	MMU Select 1
4	Interrupt sensitivity (1 = level, 0 = edge)
5	MMU Select 2
6	Parity sense (1 = odd, 0 = even)
7	1 = BIT on power-up
8	1 = Start-Up ROM present
9	1 = DMA device present
10	1=1750A mode, 0=1750B mode
11	1=Instruction set expansion enabled
12	BPU Select 1
13	BPU Select 2
14-15	Reserved for future expansion

Figure 4: Configuration Word Bits

The processor maintains an internal configuration register which is updated from the external register during initialisation and during the execution of a NOP/BPT (No-op/Breakpoint) instruction. The internal configuration register is used to control the CPU. Note that although the external register can be read using XIO RCW, this does not affect the internal configuration. Note: if the interrupt level/edge trigger select bit - (bit 4) is changed in the internal register during normal operation of the device, one or more spurious interrupts may occur.

When in 1750B mode, the processor needs to know how many Page Banks are implemented in the external system so that Status Word changes can be protected properly. MIL-STD-1750B allows the options 0,1,2,4,8 or 16. The actual selection should be coded into the three configuration register bits MMU0, MMU1 and MMU2 as shown in figure 5.

In 1750A mode, setting any of the MMU select bits indicates the presence of an MMU, the actual code is unimportant in this mode.

BPU selects bits 2:0 should be set to indicate how much BPU-protected memory exists on the system. If no BPU is present, all three bits should be zero.

Selected bit			Function
MMU2	MMU1	MMU0	
0	0	0	No MMU in system
0	0	1	1 Page Bank (PB0)
0	1	0	2 Page Banks (PB0-1)
0	1	1	4 Page Banks (PB0-3)
1	0	0	8 Page Banks (PB0-7)
1	0	1	16 Page Banks (PB0-15)
1	1	X	16 Page Banks (PB0-15)

Note: In 1750A mode, setting any or all of the MMU select bits indicates the presence of an MMU.

Figure 5: MMU Selection Bits

3.1.2. BUILT-IN TEST (BIT)

BIT consists of ten subroutines, as outlined in Figure 6. If all ten subroutines execute successfully, or no BIT is selected in the configuration word, a BIT pass is flagged (seen externally as NPU raised high by the initialization routine). If any part of BIT fails, a corresponding bit identifying the failed subroutine is set in General Register R0, Fault Bit 13 is set in the Fault register (FT) and NPU is left in the low state. Figure 6 defines the coding of BIT results in R0. In the event of such a failure, the resulting processor reset state will be dependent on where in BIT the error occurred and may not be the same as that shown in figure 2. A BIT failure indication in FT will set the level 1 interrupt request bit of the Pending Interrupt (PI) register. Since initialisation disables and masks interrupts, this interrupt request will not be asserted. Any external interrupts or faults occurring during BIT will be cleared before program execution begins and will not be serviced.

Test Coverage	Machine Cycles	Bit set on fail
Temporary Registers (T0-T11)	47	7
General Registers (R0-R15)	79	7
Flags Block	18	8
Sequencer Operation and ROM checksum	5632	9
Divide routine Quotient Shift Network	12	10
Multiplier and ALU	13	11
Barrel shift Network	13	12
Interrupts and fault handling and detection	17	13
Address generator block	13	14
Instruction pipeline	15	15

Note: BIT pass is indicated by all zeros in FT bits 13,14, and 15

Figure 6: Built-In Test Coverage

3.2. INSTRUCTION EXECUTION

Once initialisation has been completed, the processor will begin instruction execution. Instruction execution is characterised by a variety of operations, each is one machine cycle in duration (two or more system CLK periods). Depending on the instruction being executed at the time, these operations include: (1) internal CPU cycles, (2) instruction fetches, (3) operand transfers, and (4) input/output transfers.

Instruction execution may be interrupted at the end of any individual machine cycle by an interrupt or Console request. Internal cycles are always two CLK periods long, whilst the other cycle types are a minimum of two CLK periods - extendable by inserting waitstates. In all cycles except internal cycles, RDN, WRN, DSN and AS strobes are produced to control the transfer and latching of data and address around the system.

Cycle Type	RD/WRN	O/IN	M/ION	Description
Internal Cycle	H	L	H	Used to perform all CPU data manipulation operations where bus activity is not required.
Instruction Fetch	H	L	H	Used to keep the instruction pipeline full with instructions and/or their postwords. At least one instruction is always ready for execution when the preceding instruction is completed. During jump and branch instruction execution the pipeline is refilled by two consecutive instruction fetches starting at the new instruction location. It is also refilled as part of interrupt request processing.
Operand Read Operand Write	H L	H H	H H	Used to read in data from the external system and to write results to the system.
IO Read IO Write	H L	H H	L L	Input/Output transfers utilize the MIL-STD-1750 XIO and VIO instructions. RD/WRN defines the direction of the transfer. IO transfers may be divided into three groups; those commands which are implemented internally by the CPU, those commands which are implemented by external system hardware and those commands defined as illegal by MIL-STD-1750A and B.

Figure 7: External Cycle Types

3.3. IO OPERATION

The MA31750 supports a 64KWord addressing space dedicated to IO control and communication in accordance with MIL-STD-1750. The control line MION is asserted low when accessing IO space (see figure 7 above for other strobe states). One of the two commands XIO or VIO is used to specify both data for the transfer and the port address (referred to as an XIO Command in 1750). The CPU contains logic which decodes all internally supported XIO commands and generates the control signals necessary to carry out the commanded action. In addition, the validity of a command not implemented internally is verified. Figure 20c identifies the XIO commands which are internally supported by the MA31750.

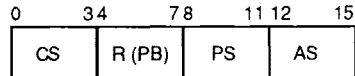

3.4. INTERRUPT AND FAULT HANDLING

3.4.1. STATUS WORD (SW)

Figure 8 depicts the status register format. This 16-bit word is divided into four, 4-bit sections. Three of these sections [AS, PS and, (1750B mode) PB] are control bits for implementing expanded memory with an external MMU. The fourth section, CS, is used to hold the carry, positive, zero and negative condition flags set by the result of the previous arithmetic operation.

Field	Bits	Description
CS	0 1 2 3	CONDITION STATUS C- Carry from an addition or no borrow from a subtraction. P- Result > 0 Z- Result = 0 N- Result < 0
R PB	4-7	RESERVED (=0) in 1750A mode Page Bank Select in 1750B mode
PS	8-11	PROCESSOR STATE: (a)- Memory access to key code (b)- Privileged instruction enable
AS	12-15	ADDRESS STATE: Page register sets for expanded memory addressing.

Figure 8: Status Word Format

MA31750

The AS field is used during expanded memory access to define the page register set to be used for instruction and operand memory references. The PS field is used during memory protect operations to define the access key used for memory accesses. The PS field is also used during execution of privileged Instructions - PS must be zero for such operations to be legal. See Section 4.3 for further information on the use of this field. The PB field is used in conjunction with the AS field in 1750B mode to expand the number of page registers available. Note that attempting to set AS or PB to a non-zero value with no MMU, or setting PB to a non-zero value in 1750A mode is illegal. This will be aborted and a fault 11 will be generated (SW will remain unchanged).

3.4.2. PENDING INTERRUPT REGISTER (PI)

This 16-bit register is used to capture and hold interrupts until they can be processed by microcode and user software. A logic 1 is used to represent an active pending interrupt. The PI register supports three dedicated external, six user-definable external, and seven dedicated internal interrupts. Level-sensitive interrupts are sampled on each rising CLK edge, whilst edge sensitive interrupts are captured immediately.

System Interrupts		Internal Interrupts	System Faults		Internal Faults
PWRD	0	(Cannot be disabled or masked)	MPROE (CPU)	0	
	1	Machine Error (Cannot be disabled)	MPROE (DMA)	1	
INT02	2		PE (CPU memory)	2	
	3	Floating-Point Overflow	PE (CPU IO)	3	
	4	Fixed-Point Overflow	PE (DMA)	4	
	5	Executive call (Cannot be disabled or masked)	EXADE or Bus Timeout (CPU IO)	5	
	6	Floating-Point Underflow		6	Parallel IO Transfer Error
	7	Timer A Overflow	FLT7	7	
INT08	8		EXADE or Bus Timeout (CPU memory)	8	
	9	Timer B Overflow		9	Illegal Instruction Opcode
INT10	10			10	Privileged Instruction
INT11	11			11	Unimplemented Address State
IO11	12		Reserved	12	
INT13	13			13	MA31750 BIT Fail
IO12	14		EXADE (DMA)	14	
INT15	15		SYSF	15	

Figure 9: Pending Interrupt Bit Assignments

Figure 10: Fault Register Bit Assignments

3.4.3. MASK REGISTER (MK)

This 16-bit register is used to store the interrupt mask. Interrupts are masked by ANDing each mask bit with its corresponding PI register bit. ie. A logic zero in a given bit position indicates that the corresponding bit in the PI register will be masked. Interrupts which are masked will be captured in the PI register but will not be acted on until unmasked. Interrupt level zero can not be masked.

3.4.4. PRIORITY ENCODER

This encoder generates an interrupt request to the sequencer block whenever one or more unmasked interrupts are pending and enabled in the PI. The highest priority unmasked pending interrupt is encoded as a 4-bit vector. This vector is used during interrupt servicing in order to create the interrupt linkage and service pointers.

3.4.5. FAULT REGISTER (FT)

This 16-bit register is used to capture and hold both internal and user implemented external faults using positive logic, i.e., a logic one represents a fault. Bus cycle faults are captured at the end of each machine cycle whilst the two general purpose faults SYSFN and FLT7N are set when the low time exceeds the minimum pulse width. Setting any one or more faults in FT will cause a level 1 (machine error) interrupt request. Once a fault is set in FT, it may only be cleared via an XIO command.

In 1750B mode, a fault mask register is provided to allow selective masking of fault conditions. Section 4 (Software Considerations) contains further information.

3.4.6. INTERRUPT SERVICING

Nine user interrupt request inputs are provided for programmed response to asynchronous system events. A low on any of these inputs will be detected at the rising edge of CLK (level sensitive interrupts only) and latched into the Pending Interrupt (PI) register on the falling edge of CLK at the end of the current CPU cycle. This sequence occurs whether interrupts are enabled or disabled or whether the specific interrupt is masked or unmasked. More details of interrupt operations are available in Applications Note 4.

All of the user interrupts PWRDN, INT02N - INT15N may be programmed to be either level or edge sensitive by setting or clearing the appropriate bit in the system configuration register. If edge sensitivity is selected then an interrupt request input must return to the high state before a subsequent request on that input will be detected. If level sensitivity is selected then holding an interrupt input low will cause a new interrupt to be latched following each service. Note that interrupts IO11N and IO12N are level sensitive only.

In order that the system may recognise when a service has been started, an interrupt acknowledge pin is provided. During the microcoded interrupt service routine execution, the processor will read the Linkage Pointer address in memory. During this operand read cycle, the processor will also assert INTAKN low, which may be used in conjunction with AS and address bus bits A[11:14] to reveal the priority level of the interrupt being serviced. (A[11:14] = 0 indicates level 0 interrupt, A[11:14] = 1 indicates level 1 interrupt, and so on). INTAKN should also be used to remove level-sensitive interrupt requests to ensure that repeated requests are not generated.

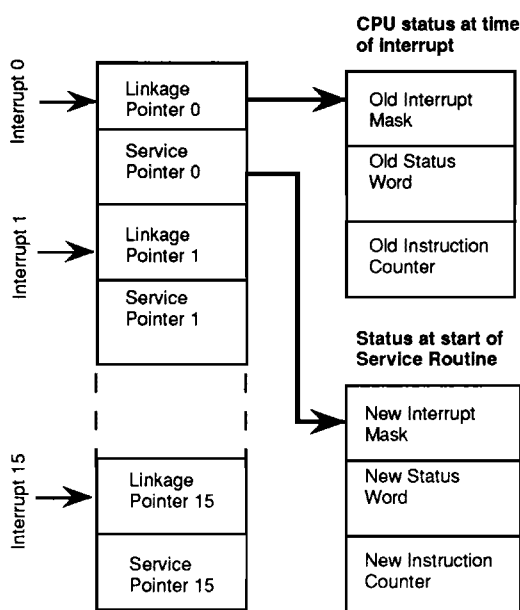

Figure 11: Interrupt Vectoring

When an interrupt request is latched into PI, it is ANDed with its corresponding mask bit in the mask register (MK). NOTE: Interrupt level 0 is non-maskable. Any unmasked pending interrupts are output to the priority encoder where the highest priority is encoded as a 4-bit vector. If interrupts are enabled and an unmasked interrupt is pending, the priority encoder will assert an interrupt request to the sequencer. 1 or 2 extra CLKs will be inserted into the machine cycle on which the interrupt request is asserted.

	Interrupt No.	LP Address	SP Address
PWRD	0	20	21
ME	1	22	23
INT02	2	24	25
Fl.P o/f	3	26	27
Fx.P o/f	4	28	29
BEX	5	2A	2B
Fl.P u/f	6	2C	2D
Timer A	7	2E	2F
INT08	8	30	31
Timer B	9	32	33
INT10	10	34	35
INT11	11	36	37
IO11	12	38	39
INT13	13	3A	3B
IO12	14	3C	3D
INT15	15	3E	3F

Note: Addresses (in hex) are in operand space

Figure 12: Interrupt Pointer Address

MA31750

Upon completing execution of each MIL-STD-1750A or B instruction, the sequencer checks the state of the priority encoder interrupt request. If a request is asserted, the sequencer branches to the microcode interrupt service routine. This routine reads the 4-bit pending interrupt vector and then uses this value to calculate the appropriate interrupt linkage (old processor context save area) and service (new context load area) pointers. Figure 11 depicts this relationship. Figure 12 defines the pointer values.

Using the linkage and service pointers, the microcode interrupt service routine performs the following: (1) the current contents of the status word, mask register, and instruction counter are saved; (2) a write status word (WSW) I/O command is executed with an all zero data word; (3) the new mask is loaded into MK and interrupts are disabled; (4) the new status word is read and checked for a valid Address State (AS[0:3]) field - If the address state is non-zero and an MMU is not present, AS[0:3] is set to zero and fault 11 (address state error) is set in the fault register FT); (5) a write status word command using the new status word is performed; and (6) the new IC value is loaded into IC, the instruction pipeline is flushed and refilled starting at the new address, and instruction execution begins.

[NOTE: The steps listed above represent a summary of actions performed during interrupt servicing and do not necessarily reflect the actual order in which these events take place.]

If an address state fault occurs during the service routine, interrupt level 1 will be set. This interrupt will be serviced when interrupts are re-enabled unless it is masked by the new value in MK.

3.4.7. FAULT SERVICING

Five user fault inputs are provided. A low on any of the three bus-cycle-related fault inputs, EXADEN, MPROEN or PEN, will be latched into the Fault Register (FT) on the next falling edge of AS. A low on either of the two general purpose fault inputs, FLT7N or SYSFN, will be latched immediately and will be sampled into the appropriate bit of FT on the falling edge of AS.

Any fault which sets a bit in the FT immediately causes a level 1 pending interrupt to be entered into the PI register. This interrupt is maskable but may not be disabled.

This interrupt will be serviced at the end of the currently executing 1750 instruction if not masked. The microcoded interrupt service routine reads the interrupt priority vector and clears the bit relating to the serviced interrupt from the PI. However, the FT retains the set fault bits until the FT is cleared using the XIO RCFR command. (A non-destructive read of the FT is provided by the XIO RFR command.) Anti-repeat logic between the FT and the PI prevents the same fault being latched and serviced twice. However, as all FT bits are ORed together and input to PI bit 1, this also prevents any other faults being serviced until the fault register has been cleared. It is imperative, therefore, that the fault service routine executes a RCFR XIO before exiting. Different types of faults are serviced slightly differently as follows:

3.4.7.1. MPROEN and EXADEN

If MPROEN and/or EXADEN are low on a falling clock edge with AS and DSN high (see figure 23a), the processor will wait in this state. If either fault input remains low during two falling edges of TCLK, the cycle is forced to complete but RDN/WRN and DSN are inhibited. This allows the processor to prevent erroneous accesses. An access fault will be registered as AS falls at the end of the cycle.

3.4.7.2. PEN

External parity errors are latched into the FT on the falling edge of AS. The fault bit set is dependant upon the type of transfer taking place (memory, IO or DMA).

3.4.7.3. FLT7N and SYSFN

These faults are latched immediately, but are not sampled into the fault register until the following falling edge of AS.

3.4.8. PARITY GENERATION AND CHECKING

The MA31750 features on-chip parity generation and checking on all data bus transfers. Data generated by the processor has a parity bit attached to it to allow external logic to verify write transfers. On read transfers, the processor will check the incoming parity (if enabled) and will generate the appropriate parity error fault if detected. However, the data to be checked is only available as DSN rises at the end of the cycle so the error flag is generated and latched in the cycle following the erroneous cycle. Parity checking may be disabled when operating with devices which do not support parity generation by asserting the DPARN (Disable Parity) input low. The checking polarity (odd or even) is selectable with Configuration Register bit 6.

3.5. TIMER OPERATIONS

The MA31750 implements interval timers A and B, a trigger-go counter, and a bus fault timer. A discussion of each follows:

3.5.1. TIMERS A AND B

Two general-purpose, 16-bit timers are provided in the processor. Timer A is clocked by the TCLK input; timer B is clocked by an internally generated TCLK/10. The divider circuit is reset when Timer B is reset to give deterministic processor operation. MIL-STD-1750 requires TCLK to be a 100kHz pulse train. If allowed to overflow, timers A and B will set level 7 and level 9 interrupt requests respectively. Each timer can be read, loaded, started and stopped by using XIO commands as identified in figure 20c.

Each timer has associated with it a reset register from which the timer is automatically loaded following a software reset or overflow. These registers are initially loaded with zero but may be reloaded from software (using the XIO instructions OTA and OTB) to provide greater control over the count period.

The MA31750 timers A and B will be disabled when the device enters Console mode, as required by MIL-STD-1750A Notice 1.

3.5.2. TRIGGER-GO COUNTER

This 16-bit counter is clocked by the TCLK input and is typically used as a system "watchdog" timer. It is enabled during system initialisation and may be preset under software control to give a wide range of timeout intervals. In order that the count period may be controlled, a reset register is provided. On reset, this register is loaded with zero, but can be reloaded under software control to take any value between 0 and $FFFF_{16}$ (a value of zero gives the maximum count period). This allows the timeout period to be varied between 20 μ s and 0.65s. Note that there is no value which disables the timer.

The counter is incremented on each TCLK falling edge. Whenever the trigger-go counter overflows, TGON drops low and remains low until the counter is reloaded from the reset register via the GO internal XIO command. TGON low would typically be used to initiate a user-defined system recovery action such as a system reset.

3.5.3. BUS FAULT TIMER

All bus operations are monitored to ensure timely completion. A hardware timeout circuit is enabled at the start of each memory and I/O transfer (DSN high-to-low transition) and is reset upon receipt of the external ready (RDYN) signal. If this circuit fails to reset within a minimum of one TCLK period or a maximum of two TCLK periods, either bit 8 (if the transaction is with memory) or bit 5 (if the transaction is with I/O) of the Fault Register (FT) is set. This sets Pending Interrupt level 1 and causes the strobes to be suppressed and the current bus cycle to be aborted. The MIL-STD-1750 instruction is aborted, and control passes to the level 1 interrupt service routine (if the level 1 interrupt is unmasked). The timeout mechanism is disabled and reset if DTON is asserted low.

3.6. CONSOLE OPERATION

The MA31750 is capable of interfacing directly to an external console, allowing the developer to: examine and change the contents of internal registers, memory and I/O devices; single step code and halt the processor. Applications Note 3 provides a full description of the Console interface, its implementation and operation.

3.7. MULTIPROCESSOR SUPPORT

Once initialisation has been completed, the processor will begin instruction execution by executing a sequence of micro-instructions, each one machine cycle (two system clock periods) long. Each machine cycle may perform either an internal or an external operation; if the operation is purely internal then the system busses will not be in use and may be reassigned to another processor.

An external machine cycle (indicated by REQN low during the second half of the previous cycle) will cause the processor to stall upon completion of the current microcycle, awaiting GRANTN asserted low. Whilst GRANTN is high the busses remain undriven.

In simple, single processor systems which use no DMA devices the GRANTN line should be tied to GND to allow the processor to retain control of the busses. The LOCKN and REQN pins can be left open-circuit in this case. Applications Note 11 provides further information for designers of systems with more than one bus master.

4. SOFTWARE CONSIDERATIONS

4.1. OPERATING MODES

The MA31750 is capable of being operated in one of two basic modes as previously mentioned. These are described in detail below:

4.1.1 1750A MODE

1750A mode is a full implementation of MIL-STD-1750A (Notice 1) and includes some of the optional features mentioned in this standard.

4.1.2 1750B MODE

1750B mode is an implementation of the proposed MIL-STD-1750B, Option 2, Draft of 17th July 1988. This mode extends the basic 1750A mode operation. Note that the transcendental functions SIN, COS, LN etc. (Option 3 of MIL-STD-1750B) are not supported. Features new to MIL-STD-1750B which are in violation of MIL-STD-1750A are only enabled in 1750B mode. The additional instructions available in 1750B mode are detailed in figure 20b.

4.2. ACCESSING IO USING XIO AND VIO COMMANDS

MIL-STD-1750 defines a 64KWord addressing space which is available exclusively for accessing I/O resources. Two special commands, XIO and VIO, are provided as part of the instruction set for accessing this space. Port addresses are specified as a 16-bit Command word which is supplied as a parameter to the XIO/VIO instruction. The MSB of the Command word indicates the direction of data transfer between the port and the register specified in the XIO command (a 1 in the MSB indicates that the port is being read, whilst 0 indicates a write to the port).

MA31750

Output	Input	Usage
0000-03FF	8000-83FF	PIO
0400-1FFF	8400-9FFF	Spare
2000-20FF	A000-A0FF	CPU and auxiliary register control
2100-2FFF	A100-AFFF	Reserved
3000-3FFF	B000-BFFF	Spare
4000-40FF	C000-CFFF	CPU and auxiliary register control
4100-4CFF	C100-CCFF	Reserved
4D00-4FFF	CD00-CFFF	Extended memory protect RAM
5000-50FF	D000-D0FF	Memory protect RAM
5100-51FF	D100-D1FF	MMU Instruction Page Registers
5200-52FF	D200-D2FF	MMU Operand Page Registers
5300-7FFF	D300-FFFF	Spare

Figure 13: XIO Command Channel Grouping

XIO command addresses are grouped by the Standard according to function. Certain groups are 'reserved' and must not be implemented. Attempts to read or write these areas will be prevented by the processor and a fault will be logged in the fault register. Other groups are designated 'spare' and may be implemented as required by the system designer. Note, however, that there is a third group which access system resources such as MMU page registers and interrupt control registers which are not available to the user to implement. A summary of the XIO map is provided in figure 13, whilst the detailed list of implemented command addresses is shown in Figure 20c.

The VIO (Vectored IO) command allows a number of IO operations to be executed in a sequence from a table. Applications Note 8 gives further information on the use of this command.

Both XIO and VIO are privileged commands and as such can only be executed when the Status Word PS field is zero.

4.3. PROCESSOR STATE AND PRIVILEGED INSTRUCTIONS

The Processor State is defined by a 4-bit value held in the processor Status Word. If the value is made non-zero then attempts to execute the commands XIO, VIO or LST will be aborted and a fault will be raised. This is intended to deny direct access to the hardware from user applications (running in PS≠0), whilst allowing the Operating System (operating with PS=0) access to the system IO and interrupt resources.

If an MMU is present on the system the PS field is used in conjunction with the page register Access Key field to provide a further level of protection to the system. When PS=0 access is granted to all pages, irrespective of their key value. If PS is non-zero, access is only permitted if the Access Key is equal to the PS value, or the Access Key is 15. Access Key 15 should be applied to a shared area of code or data, and is accessible to all PS values.

4.4. USING START-UP ROM

The transition between code execution from Start-up ROM and system RAM must be made with care. If a system overlays RAM with the Start-Up ROM and the transition is made by simply executing XIO DSUR from the ROM, then the instruction pipeline will contain the value stored in the ROM location immediately following the XIO DSUR command. This value will be treated as an instruction and the processor will attempt to execute it. In such cases, it is recommended that DSUR be followed by an unconditional branch instruction with offset, i.e. the BR instruction. An alternative approach is simply to jump to a portion of RAM not overlaid by the Start-Up ROM and execute DSUR from RAM.

4.5. USING SOFTWARE TIMERS A AND B

The MA31750 implements the two software timers, A and B as defined in the MIL-STD 1750A specification. These are general purpose timers which are clocked at 100kHz and 10kHz respectively, giving clock 'tick' intervals of 10us and 100us respectively. They may be started using the XIO TAS and XIO TBS instructions, and stopped using XIO TAH and XIO TBH. If a timer is allowed to overflow ($FFFF_{16} - 0000_{16}$) it will generate pending interrupt levels 7 (A) or 9 (B).

In 1750B mode each timer has associated with it a reset register which may be loaded with any 16-bit value from software. If a timer is allowed to overflow, an automatic reset will take place which will reload the timer with the value held in its on-chip reset register, provided that the timer had previously been loaded using XIO OTA/OTB. If this is not the case, then the timers will reset to zero on overflow. Each of the reset registers is initialised to zero but may be changed using XIO OTAR or XIO OTBR.

4.6. FAULT MASK REGISTER

A fault mask register is accessible in 1750B mode. Its function is similar to that of the Interrupt Mask register and allows selective enabling and disabling of all bits in the Fault Register. All faults are maskable. Setting a bit in this register allows the corresponding fault bit to be seen by the system. The mask register is loaded with $FFFF_{16}$ on initialisation.

4.7. GENERAL REGISTERS R0-R15

There are 16 general purpose registers defined by MIL-STD-1750; each is 16-bits wide. Adjacent registers may be concatenated to provide storage for the larger data formats (Double Integer and Float - 32-bit; Extended Float - 48-bit). The first register in the set stores the most significant data word and is the register specified when referring to the value. Wrap-around occurs between R15 and R0.

Although generally all registers are the same, certain registers are notionally assigned to particular tasks, see figure 15.

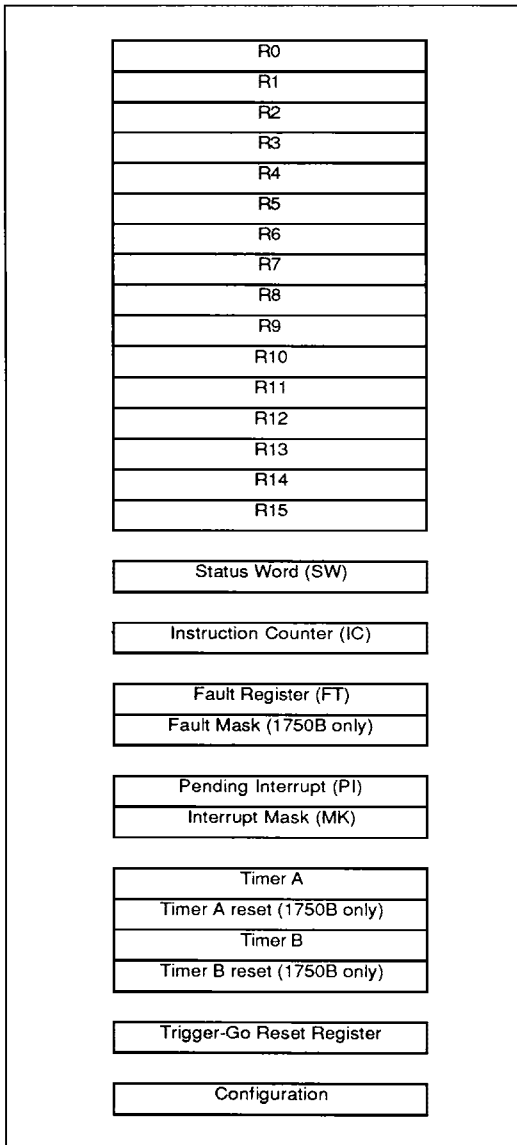

Figure 14: Register Set Model

4.8. MIL-STD-1750 DATA TYPES

The MA31750 fully supports 16-bit fixed-point single-precision, 32-bit fixed-point double-precision, 32-bit floating-point, and 48-bit extended precision floating-point data types. Figure 16 depicts the formats of these data types.

All numerical data is represented in two's complement form. Floating-point numbers are represented by a fractional two's complement mantissa with an 8-bit two's complement exponent. All floating-point operands are expected to be normalised. If not normalised, the results from an instruction are not defined.

4.9. MIL-STD-1750 ADDRESSING MODES

The MA31750 supports the eight basic addressing modes specified in MIL-STD-1750A. These addressing modes are depicted in Figure 18 and are defined below. In binary operations one operand is assumed to be in a register (specified as part of the opcode) whilst the second operand (the Derived Operand, DO) is taken from a source which is dependent upon the addressing mode, see figure 17. Many addressing modes may be specified as indexable: the index register may be any of the general purpose registers R1-R15 (if 0 is specified then the non-indexable form is used). For Base Relative addressing modes the first operand is fixed as part of the instruction (either R0 for Double Integer operations, or R2 for Single Integer operations).

4.10. MEMORY ADDRESSING CAPABILITY

In accordance with MIL-STD-1750A, the MA31750 can access a 64KWord address space directly. With the addition of a single external GEC Plessey MA31751 chip, configured as a Memory Management Unit (MMU), this address space may be expanded to 1MWord (1750A mode) or 8MWord (1750B mode). The MA31751 data sheet gives further information on the MMU/BPU chip and on the memory management scheme employed. Note that whilst one MMU can be used to provide the full range of physical addresses to the system memory, the logical addressing capability may also be expanded by adding further MMU devices up to a maximum of 16.

Register(s)	Notional Use or Restriction on Use
R0	Cannot be used as an index register With R1: Implied register in Double mode Base Relative addressing
R2	Implied register in Single mode Base Relative addressing
R3-R11	General purpose
R12-R15	Base relative registers
R15	Stack pointer in PSHM and POPM operations

Figure 15: General Register Usage

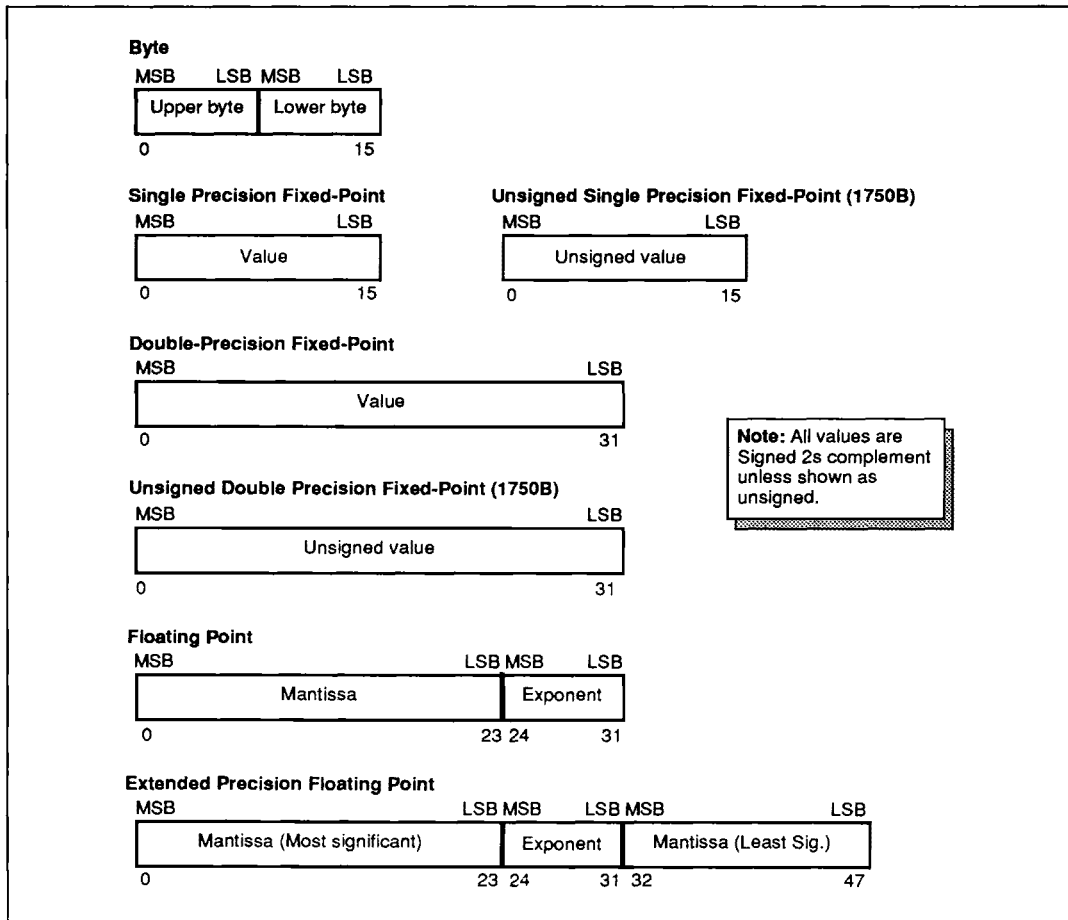

Figure 16: Data Formats

Mode	Name	Derived Operand
R	Register Direct	The operand is contained in a register specified by the instruction.
D, DX	Memory Direct	The instruction postword (plus RX if RX ≠ 0), contains the memory address of the operand.
I, IX	Memory Indirect	The instruction postword (plus RX if RX ≠ 0) contains the address of the address which holds the operand.
IM, IMX	Immediate Long	The instruction postword (plus RX if RX ≠ 0) holds the operand.
ISP	Immediate Short Positive	The operand value is specified as part of the instruction. (ISP specifies values between 0001 _H and 0010 _H , ISN specifies values between FFFF _H and FFEF _H).
ISN	Immediate Short Negative	The operand value is specified as part of the instruction. (ISP specifies values between 0001 _n and 0010 _n , ISN specifies values between FFFF _n and FFEF _n).
ICR	Instruction Counter Relative	A 2s-complement, 8-bit displacement which is sign-extended and added to the Instruction counter to provide an offset of -128 to +127.
B	Base Relative	Data at address given by: contents of specified base register (R12-R15, specified by opcode), plus unsigned 8-bit displacement field from opcode.
BX	Base Relative Indexed	Data at address given by contents of specified base register (R12-R15, specified by opcode), plus contents of RX register if RX ≠ R0
S	Special	See instruction for details.

Figure 17: Address Mode Summary

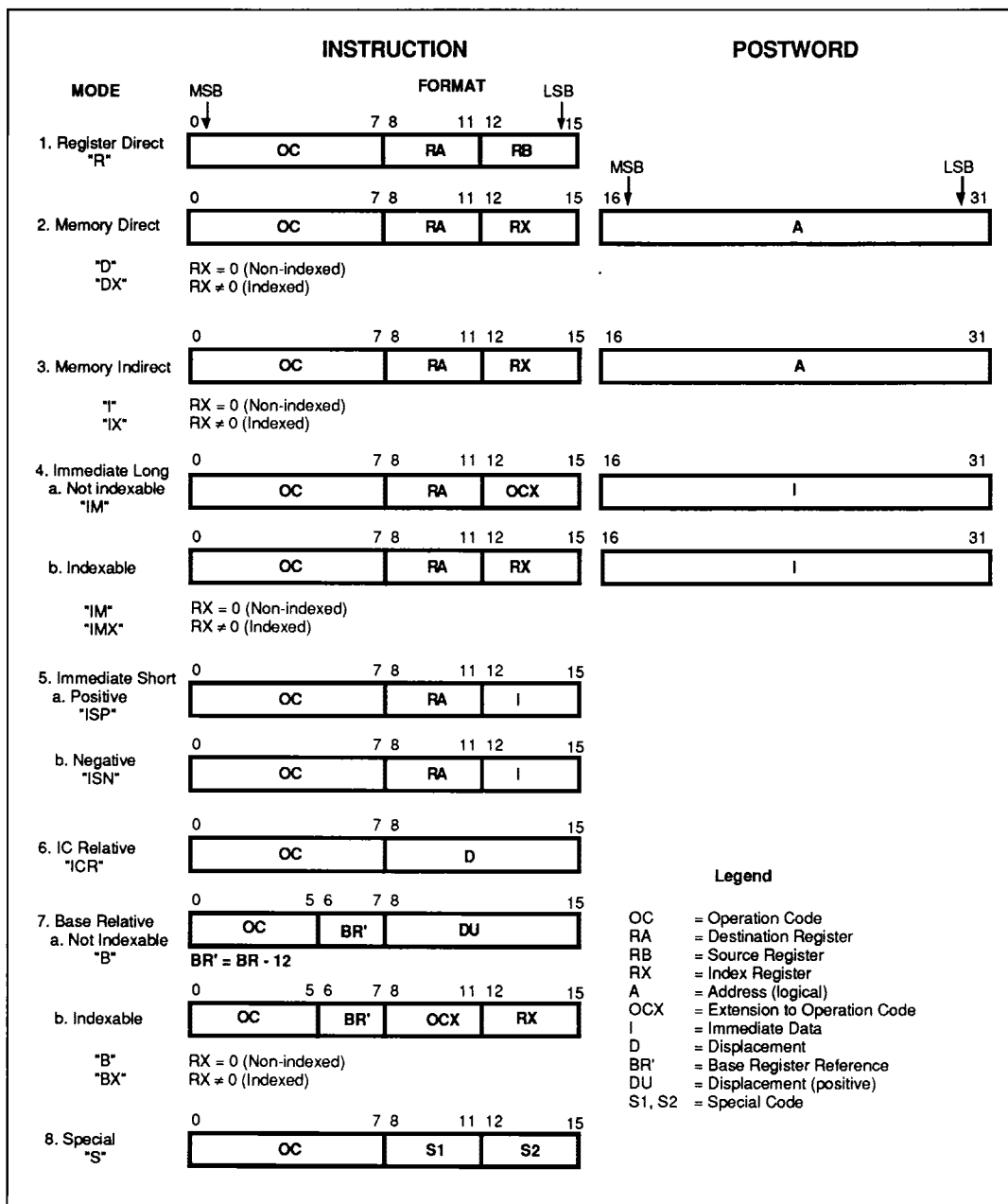

Figure 18: Addressing Modes

MA31750

5. PERFORMANCE

5.1. BENCHMARKING

Figure 20a defines the number and type of machine cycles associated with each MIL-STD-1750 instruction. This information may be used when benchmarking MA31750 performance. The Digital Avionics Instruction Set (DAIS) mix, which defines a typical frequency of occurrence for MIL-STD-1750A instructions, is used here for this purpose.

One problem with the DAIS mix is that it does not reflect the impact of data dependencies on system performance. E.g. a multiplication in which the operand is zero may be performed much faster than one with two non-zero operands.

Realistic benchmarks must therefore take both the instruction mix and data dependencies into account. To this end, machine cycle counts in figure 20a which have data dependencies are annotated with either an "a" or "wa" suffix.

An "a" suffix reflects an average number of machine cycles (where each of several possibilities is equally likely) and a "wa" suffix reflects a weighted average number of machine cycles (where some data possibilities are more likely than others).

Weighted averages are only applicable to floating-point operations. Normalisation and alignment operations are also represented. Figure 19 shows MA31750 throughput, at various frequencies and wait states, for the floating point DAIS mix.

5.2. EXPANDED MEMORY PERFORMANCE

The inclusion of an MMU (Memory Management Unit) will degrade the throughput performance of the processor in two ways. Firstly, each memory access will have an additional overhead associated with the formation of the extended address from the MMU. This may require that the processor inserts wait states to lengthen each external cycle. Secondly, the MMU itself may require that some 'housekeeping' work be done by the processor, which will lengthen the program execution time. There are no widely accepted benchmarks which may be used to measure the resultant decrease in throughput.

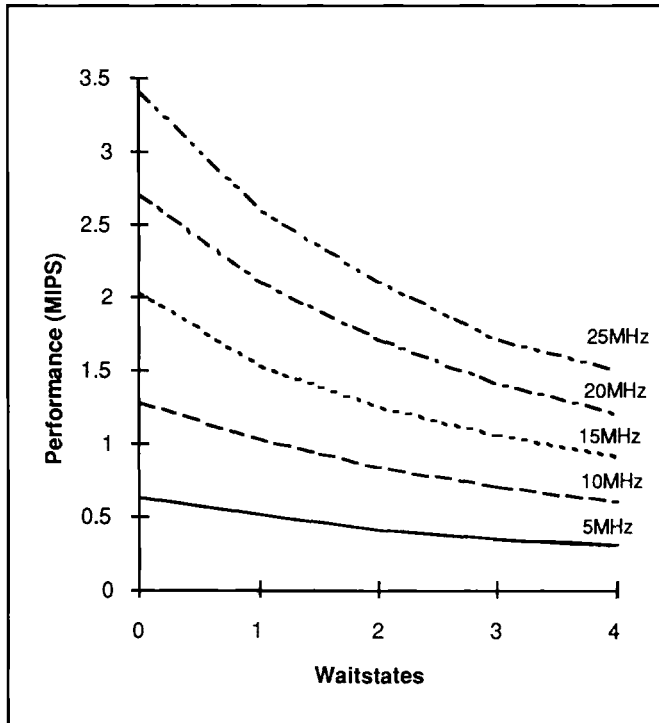

Figure 19: Throughput (MIPS) with Waitstates

5.3. INSTRUCTION SUMMARY

OPERATION	Mnem.	Format	Opcode (Ext)	Memory cycles	Internal Cycles
SINGLE LOAD/STORE					
Single Precision Load	LR	R	81	1	0
	LB	B	0X	2	1
	LBX	BX	4X 0	2	1
	LISP	ISP	82	1	0
	LISN	ISN	83	1	0
	L	D,DX	80	3	0
	LIM	IM,IMX	85	2	0
	LI	I,IX	84	4	0
Double-Precision Load	DLR	R	87	1	0
	DLB	B	0X	3	1
	DLBX	BX	4X 1	3	1
	DL	D,DX	86	4	0
Single-Precision Store	DLI	I,IX	88	5	0
	STB	B	0X	2	0
	STBX	BX	4X 2	2	1
Store Non-Negative Constant	ST	D,DX	90	3	0
	STI	I,IX	94	4	0
	STC	D,DX	91	3	0
Double-Precision Store	STCI	I,IX	92	4	0
	DSTB	B	0X	3	0
	DSTX	BX	4X 3	3	1
	DST	D,DX	96	4	0
Load Multiple Registers	DSTI	I,IX	98	5	0
	LM	D,DX	89	3+n	0
Store Multiple Registers	STM	D,DX	99	2+n	1
COMPARE					
Single-Precision Compare	CR	R	F1	1	0
	CB	B	3X	2	1
	CBX	BX	4X C	2	1
	CISP	ISP	F2	1	1
	CISN	ISN	F3	1	0
	C	D,DX	F0	3	0
	CIM	M	4A A	2	0
	CBL	D,DX	F4	4	2.7a
Compare Between Limits	DCR	R	F7	1	0
	DC	D,DX	F6	4	0
BYTE					
Load From Upper Byte	LUB	D,DX	8B	3	1
	LUBI	I,IX	8D	4	1
Load From Lower Byte	LLB	D,DX	8C	3	0
	LLBI	I,IX	8E	4	0
Store Into Upper Byte	STUB	D,DX	9B	4	0
	SUBI	I,IX	9D	5	0
Store Into Lower Byte	STLB	D,DX	9C	4	1
	SLBI	I,IX	9E	5	1
Exchange Bytes in Register	XBR	S	EC	1	0

Figure 20a: Instruction Summary

MA31750

OPERATION	Mnem.	Format	Opcode (Ext)	Memory cycles	Internal Cycles
INTEGER ARITHMETIC					
Single-Precision Integer Add	AR	R	A1	1	0
	AB	B	1X	2	1
	ABX	BX	4X 4	2	1
	AISP	ISP	A2	1	0
	A	D,DX	A0	3	0
Increment Memory by a Positive Integer	AIM	M	4A 1	2	0
	INCM	D,DX	A3	4	0
Single-Precision Absolute Value	ABS	R	A4	1	1.5a
Double-Precision Absolute Value	DABS	R	A5	1	1.5a
Double-Precision Integer Add	DAR	R	A7	1	0
	DA	D,DX	A6	4	0
Single Precision Integer Subtract	SR	R	B1	1	0
	SBB	B	1X	2	1
	SBBX	BX	4X 5	2	1
	SISP	ISP	B2	1	1
	S	D,DX	B0	3	0
Decrement Memory by a Positive Integer	SIM	M	4A 2	2	0
	DECM	D,DX	B3	4	0
	NEG	R	B4	1	1
Single-Precision Negate	DNEG	R	B5	1	1
Double-Precision Negate	DSR	R	B7	1	0
Double-Precision Integer Subtract	DS	D,DX	B6	4	0
Single-Precision Integer Multiply with 16-Bit Product	MSR	R	C1	1	2
	MISP	ISP	C2	1	2
	MISN	ISN	C3	1	3
	MS	D,DX	C0	3	2
	MSIM	M	4A 4	2	2
Single-Precision Integer Multiply with 32-Bit Product	MR	R	C5	1	1
	MB	B	1X	2	2
	MBX	BX	4X 6	2	2
	M	D,DX	C4	3	1
Double-Precision Integer Multiply	MIM	M	4A 3	2	1
	DMR	R	C7	1	16.5a
Single-Precision Integer Divide with 16-Bit Dividend	DM	D,DX	C6	4	16.5a
	DVR	R	D1	1	23.5a
	DISP	ISP	D2	1	23.5a
Single-Precision Integer Divide with 32-Bit Dividend	DISN	ISN	D3	1	23.5a
	DV	D,DX	D0	3	23.5a
	DVIM	M	4A 6	2	23.5a
	DR	R	D5	1	28a
	DB	R	1X	2	29a
Double-Precision Integer Divide	DBX	BX	4X 7	2	29a
	D	D,DX	D4	3	28a
	DIM	M	4A 5	2	28a
	DDR	R	D7	1	41a
	DD	D,DX	D6	4	41a

Figure 20a (continued): Instruction Summary

OPERATION	Mnem.	Format	Opcode (Ext)	Memory cycles	Internal Cycles
LOGICAL					
Inclusive Logical-OR	ORR	R	E1	1	0
	ORB	B	3X	2	1
	ORBX	BX	4X F	2	1
	OR	D,DX	E0	3	0
Logical-AND	ORIM	M	4A 8	2	0
	ANDR	R	E3	1	0
	ANDB	B	3X	2	1
	ANDX	BX	4X E	2	1
Exclusive Logical-OR	AND	D,DX	E2	3	0
	ANDM	M	4A 7	2	0
	XORR	R	E5	1	0
	XOR	D,DX	E4	3	0
Logical NAND	XORM	M	4A 9	2	0
	NR	R	E7	1	0
	N	D,DX	E6	3	0
Set Bit	NIM	M	4A B	2	0
	SBR	R	51	1	0
	SB	D,DX	50	4	0
Reset Bit	SBI	I,IX	52	5	0
	RBR	R	54	1	0
	RB	D,DX	53	4	0
Test Bit	RBI	I,IX	55	5	0
	TBR	R	57	1	0
	TB	D,DX	56	3	0
Test and Set Bit	TBI	I,IX	58	4	0
Set Variable Bit	TSB	D,DX	59	2	2.5a
Reset Variable Bit	SVBR	R	5A	1	0
Test Variable Bit	RVBR	R	5C	1	0
Store Register Through Mask	TVBR	R	5E	1	0
	SRM	D,DX	97	4	1
JUMP/BRANCH					
Jump on Condition	JC	D,DX	70	3a	0
	JCI	I,IX	71	3.5a	0
Jump to Subroutine	JS	D,DX	72	2	1
Subtract One and Jump	SOJ	D,DX	73	3a	0
Branch Unconditionally	BR	ICR	74	2	1
Branch if Equal to (Zero)	BEZ	ICR	75	2a	0
Branch if Less than (Zero)	BLT	ICR	76	2a	0
Branch to Executive	BEX	S	77	11	14
Branch if Less than or Equal to (Zero)	BLE	ICR	78	2a	0
Branch if Greater than (Zero)	BGT	ICR	79	2a	0
Branch if Not Equal to (Zero)	BNZ	ICR	7A	2a	0
Branch if Greater than or Equal to (Zero)	BGE	ICR	7B	2a	0

Figure 20a (continued): Instruction Summary

MA31750

OPERATION	Mnem.	Format	Opcode (Ext)	Memory cycles	Internal Cycles
EXTENDED PRECISION					
Extended-Precision Floating-Point Load	EFL	D,DX	8A	5	0
Extended-Precision Floating-Point Store	EFST	D,DX	9A	5	0
Floating-Point Absolute Value of Register	FABS	R	AC	1	2wa
Floating-Point Negate Register	FNEG	R	BC	1	3wa
Floating-Point Compare	FCR	R	F9	1	3.7wa
	FCB	B	3X	3	3.7wa
	FCBX	BX	4X D	3	3.7wa
	FC	D,DX	F8	4	3.7wa
Extended-Precision Floating-Point Compare	EFGR	R	FB	1	4wa
	EFC	D,DX	FA	5	2wa
Floating-Point Add	FAR	R	A9	1	7wa
	FAB	B	2X	3	8.5wa
	FABX	BX	4X 8	3	8.5wa
	FA	D,DX	A8	4	8.5wa
Extended-Precision Floating-Point Add	EFAR	R	AB	1	21wa
	EFA	D,DX	AA	5	20wa
Floating-Point Subtract	FSR	R	B9	1	9wa
	FSB	B	2X	3	10wa
	FSBX	BX	4X 9	3	10wa
	FS	D,DX	B8	4	9wa
Extended-Precision Floating-Point Subtract	EFGR	R	BB	1	23wa
	EFS	D,DX	BA	5	22wa
Floating-Point Multiply	FMR	R	C9	1	1
	FMB	B	2X	3	2
	FMBX	BX	4X A	3	2
	FM	D,DX	C8	4	1
Extended-Precision Floating-Point Multiply	EFMR	R	CB	1	33wa
	EFM	D,DX	CA	5	32wa
Floating-Point Divide	FDR	R	D9	1	42.8wa
	FDB	B	2X	3	43.8wa
	FDBX	BX	4X B	3	43.8wa
	FD	D,DX	D8	4	42.8wa
Extended-Precision Floating-Point Divide	EFDR	R	DB	1	112.6wa
	EFD	D,DX	DA	5	112.6wa
STACK					
Stack IC and Jump to Subroutine	SJS	D,DX	7E	3	1
Unstack IC and return from Subroutine	URS	S	7F	3	1
Pop Multiple registers off the Stack	POPM	S	8F	1+n (n=0 to 15)	4
Push Multiple Registers onto the Stack	PSHM	S	9F	1+n (n=0 to 15)	8

Figure 20a: Instruction Summary

OPERATION	Mnem.	Format	Opcode (Ext)	Memory cycles	Internal Cycles
CONVERT					
Convert Floating-Point to 16-Bit Integer	FIX	R	E8	1	7.1a
Convert 16-Bit Integer to Floating-Point	FLT	R	E9	1	3
Convert Extended-Precision Floating-Point to 32-Bit Integer	EFIX	R	EA	1	8.5a
Convert 32-Bit Integer to Extended-Precision Floating-Point	EFLT	R	EB	1	9
SHIFT					
Shift Left Logical	SLL	R	60	1	0
Shift Right Logical	SRL	R	61	1	0
Shift Right Arithmetic	SRA	R	62	1	0
Shift Left Cyclic	SLC	R	63	1	0
Double Shift Left Logical	DSLL	R	65	1	0
Double Shift Right Logical	DSRL	R	66	1	0
Double Shift Right Arithmetic	DSRA	R	67	1	0
Double Shift Left Cyclic	DSLCL	R	68	1	0
Shift Logical, Count in Register	SLR	R	6A	1	2
Shift Arithmetic, Count in Register	SAR	R	6B	1	5a
Shift Cyclic, Count in Register	SCR	R	6C	1	2
Double Shift Logical, Count in Register	DSLRL	R	6D	1	2
Double Shift Arithmetic, Count in Register	DSAR	R	6E	1	5
Double Shift Cyclic, Count in Register	DSCR	R	6F	1	2
I/O (See I/O Command Summary)					
Execute I/O	XIO**	IM,IMX	48	3	4.3a
Vectored I/O (n transfers)	VIO**	D,DX	49	***	***
SPECIAL					
Move Multiple Words, Memory-to-memory (n-words moved)	MOV	S	93	1+2n	7
Exchange Words in Registers	XWR	R	ED	1	2
Load Status	LST**	D,DX	7D	6	1
	LSTI**	I,X	7C	7	1
No Operation	NOP	S	FF 00	1	2
Break Point	BPT	S	FF FF	1	6

Figure 20a (continued): Instruction Summary

MA31750

OPERATION	Mnem.	Format	Opcode (Ext)	Memory cycles	Internal Cycles
-----------	-------	--------	--------------	---------------	-----------------

1750B MODE INSTRUCTIONS The following instructions may only be executed in 1750B mode and are illegal in 1750A					
'LONG' LOADS AND STORES					
Long Load Single	LSL	S	CC	3	11
Long Load Double	LDL	S	CD	4	20
Long Load Extended Precision Floating-Point	LEFL	S	CE	5	27
Long Store Single	LSS	S	DC	4	9
Long Store Double	LDS	S	DD	6	16
Long Store Extended Precision Floating-Point	LEFS	S	DE	8	23
UNSIGNED ARITHMETIC					
Unsigned Integer Add	UAR	R	AD	1	4
	UA	D,DX	AE	3	4
Unsigned Integer Subtract	USR	R	BD	1	4
	US	D,DX	BE	3	4
Unsigned Integer Compare	UCR	R	FC	1	5
	UC	D,DX	FD	3	5
	UCIM	IM	4A 0	2	5
BYTE LOADS AND STORES					
Load Byte	LBY	S	BF	2	3
Load Byte With Increment	LBYI	S	AF	2	3
Store Byte	SBY	S	DF	2	3
Store Byte With Increment	SBYI	S	CF	2	3
BIT OPERATION					
Search First Bit Set	SFBS	R	95	1	3.75a

Notes:

- a Average if more than one alternative exists.
- wa Weighted average where data dependency exists.
- ** Privileged instruction - illegal if PS≠0.
- *** VIO execution time dependent on number and type of transfer.

Figure 20b: MIL-STD-1750B Instruction Summary

5.4 I/O COMMAND SUMMARY

Operation	Mnem	Code	Ext ¹
-----------	------	------	------------------

Implemented in CPU 1750A or B mode			
Set Interrupt Mask	SMK	2000	No
Clear Interrupt Request	CLIR	2001	No
Enable Interrupts	ENBL	2002	No
Disable Interrupts	DSBL	2003	No
Reset Pending Interrupt	RPI	2004	No
Set Pending Interrupt Reg.	SPI	2005	No
Write Output Discrete Reg.	OD	2008	Yes
Reset Normal Power Up Line	RNS	200A	No
Write Status Word	WSW	200E	Yes
Enable Start-Up ROM ³	ESUR	4004	No
Disable Start-Up ROM ³	DSUR	4005	No
Direct Memory Access Enable ³	DMAE	4006	No
Direct Memory Access Disable ³	DMAD	4007	No
Timer A Start	TAS	4008	No
Timer A Halt	TAH	4009	No
Output Timer A	OTA	400A	No
Reset Trigger-Go	GO	400B	No
Timer B Start	TBS	400C	No
Timer B Halt	TBH	400D	No
Output Timer B	OTB	400E	No
Read Interrupt Mask	RMK	A000	No
Read Pending Interrupt Reg.	RPIR	A004	No
Read Output Discrete Reg.	RDOOR	A008	Yes
Read Status Word	RSW	A00E	No
Read and Clear Fault Reg.	RCFR	A00F	No
Input Timer A	ITA	C00A	No
Input Timer B	ITB	C00E	No
Read Memory Fault Status	RMFS	A00D	No

GPS Defined XIOs			
Set Fault Register	SFR	0401	No
Load OAS register	LOS	0406	No
Output Trigger-Go Reset Reg.	OTGR	040E	No
Write Page Bank Select	WPBS	200C	No
Read Fault Register (No clear)	RFR	8401	No
Read Linkage Pointer	RLP	8404	No
Read Processor Status	RPS	8405	No
Read OAS register	ROS	8406	No
Read Memory Fail Page	RMFP	8407	No
Read Memory Fail Address	RMFA	8408	No
Read Internal Config. Word	ICW	840C	No
Run Built In Test	BIT	840D	No
Input Trigger-Go Reset Reg.	ITGR	840E	No
Read External Configuration	RCW	8410	Yes

Implemented in CPU, 1750B mode only.			
Output Timer A Reset Reg.	OTAR	4002	No
Output Timer B Reset Reg.	OTBR	400F	No
Input Timer A Reset Register ²	ITAR	C002	No
Input Timer B Reset Register ²	ITBR	C00F	No
Set Fault Mask	SFMK	2006	No
Write Page Bank Select	WPBS	200F	No
Read Page Bank Select	RPBS	A00C	No
Read Fault Mask	RFMK	A006	No

Implemented in BPU			
Memory Protect Enable ³	MPEN	4003	Yes
Load Memory Protect RAM ³	LMP	50XX	Yes
Read Memory Protect RAM ³	RMP	D0XX	Yes
Load Ext Mem. Protect RAM ^{3,5}	LXMP	4XXX	Yes
Read Ext. Mem. Protect RAM ^{3,5}	RXMP	CXXX	Yes

Implemented in MMU			
Write Instruction Page Reg. ³	WIPR	51XY	Yes
Write Operand Page Reg. ³	WOPR	52XY	Yes
Read Instruction Page Reg. ³	RIPR	D1XY	Yes
Read Operand Page Reg. ³	ROPR	D2XY	Yes

Implemented in Console ⁶			
Console Data Output ⁴	CO	4000	Yes
Console Command ⁴	CC	8402	Yes
Console Data Input ⁴	CI	C000	Yes

Reserved by GPS (Unavailable to the user)			
Initialise Interrupt Logic	PINIT	0403	No
Set NPU	RNPU	040A	No
Write Internal config. word	WCW	040C	No
Write Memory Config. Reg.	WMCR	0400	Yes
FMCR	FMCR	A010	No

Spare and Reserved Addresses		
Output	Input	
04XX-1FXX	84XX-9FXX	Spare
21XX-2fXX	A1XX-AFXX	Reserved
30XX-3FXX	B0XX-BFXX	Spare
41XX-4FXX	C1XX-CFXX	Reserved
53XX-7FXX	D3XX-FFXX	Spare

¹ External cycles output on the address bus² GPS defined 1750B XIO's **Reserved Addresses**³ Command illegal if device not implemented in config word⁴ External cycle needing external ready generation⁵ Only implemented in 1750B⁶ The address 4001 and C001 are implemented but have no effect in the 31750.

Figure 20c: Internal I/O Command Summary

6. TIMING DIAGRAMS

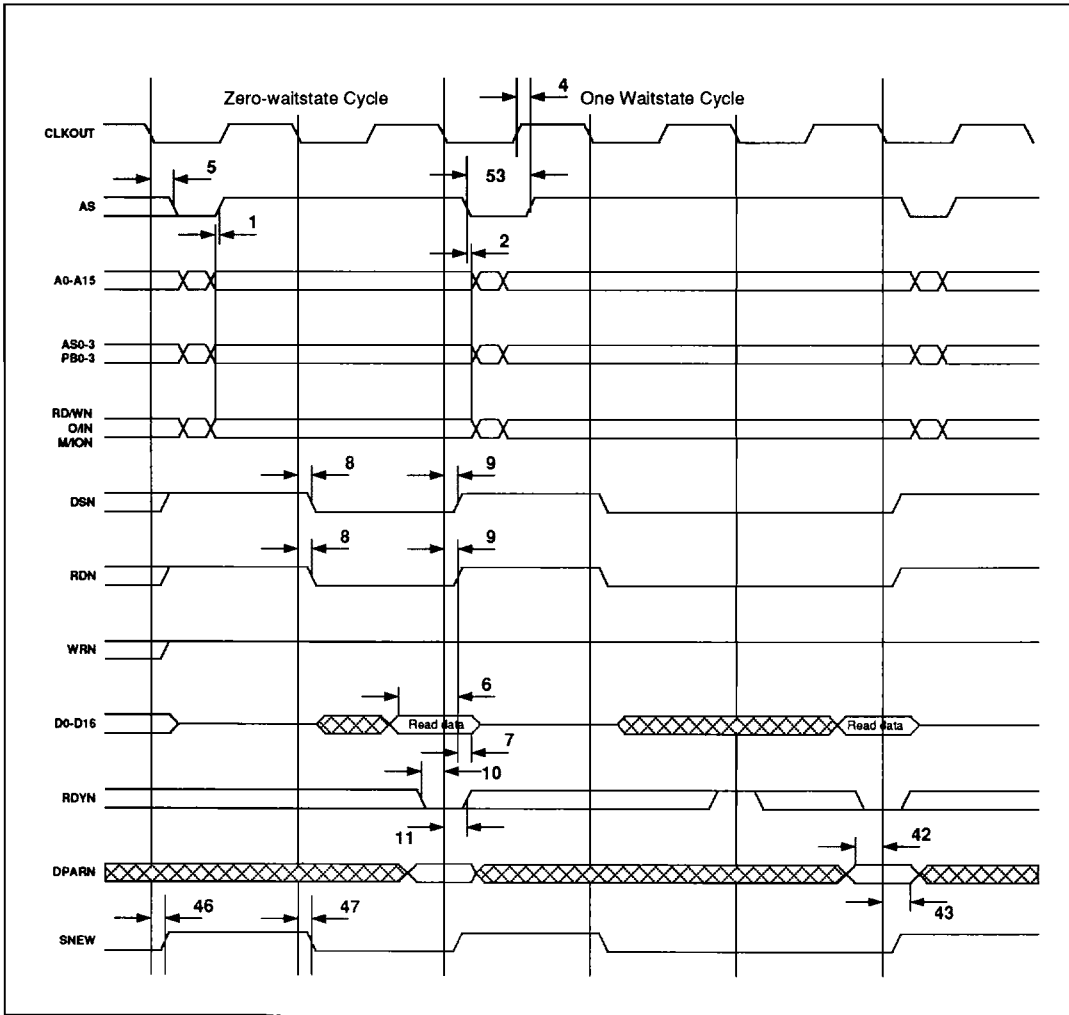

Figure 21: Read Cycle Timings

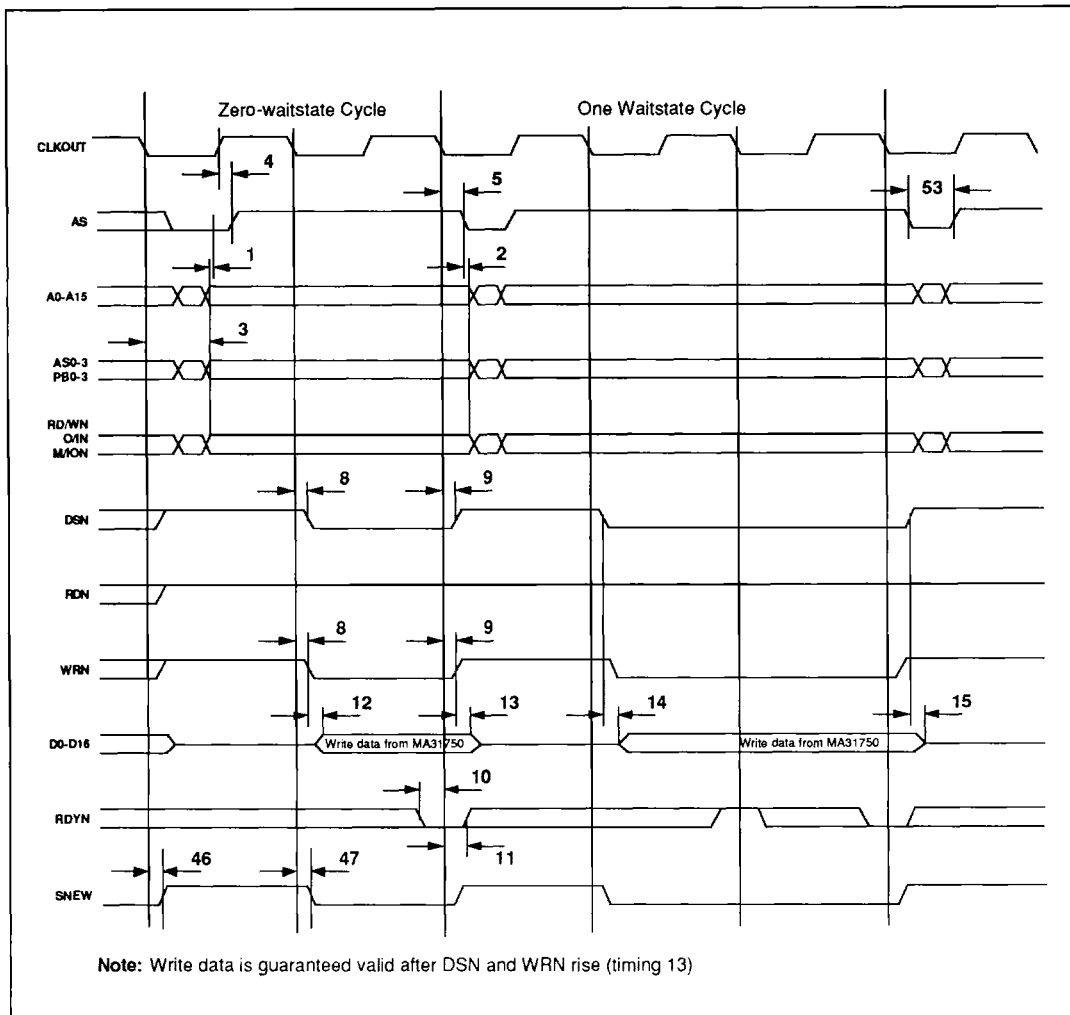

Figure 22: Write Cycle Timings

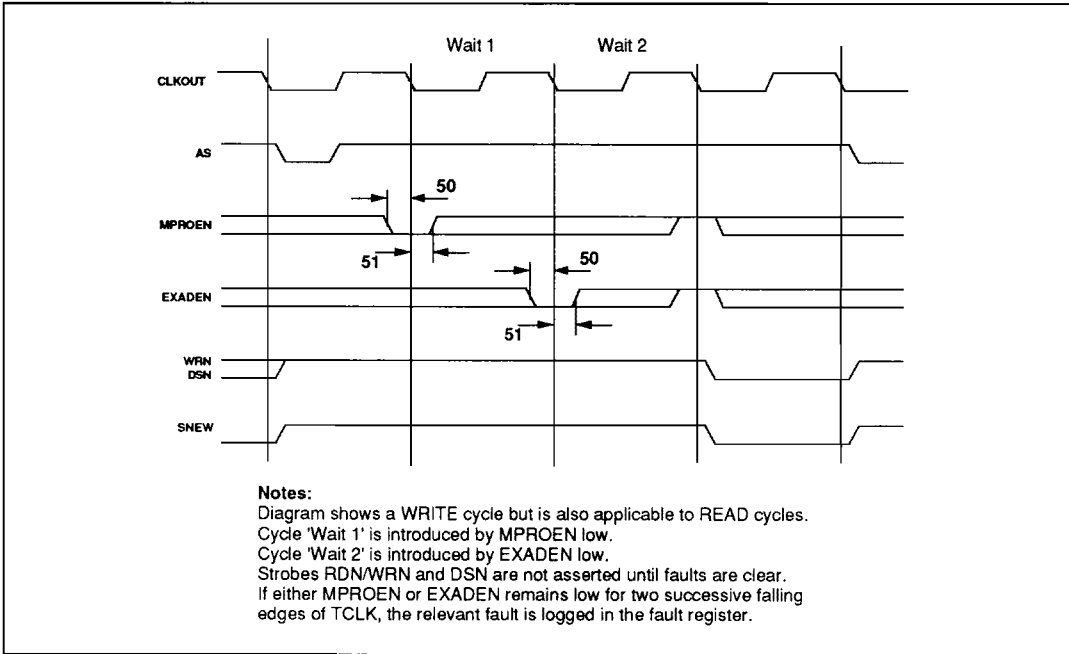

Figure 23a: MPROEN and EXADEN Timings

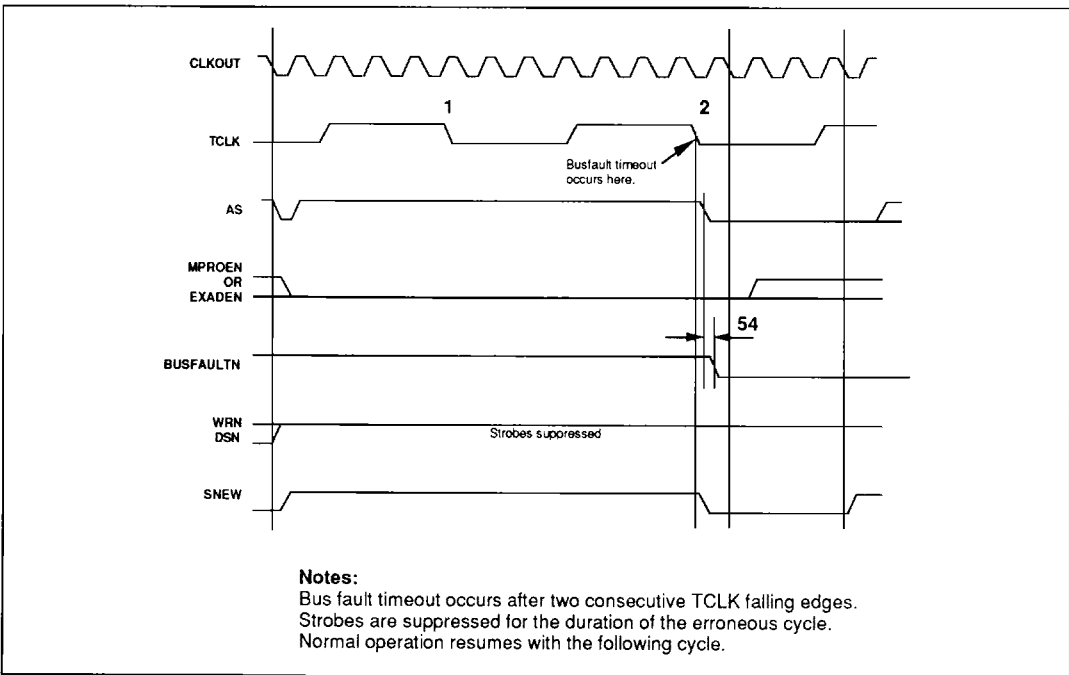

Figure 23b: Bus Fault Timeout

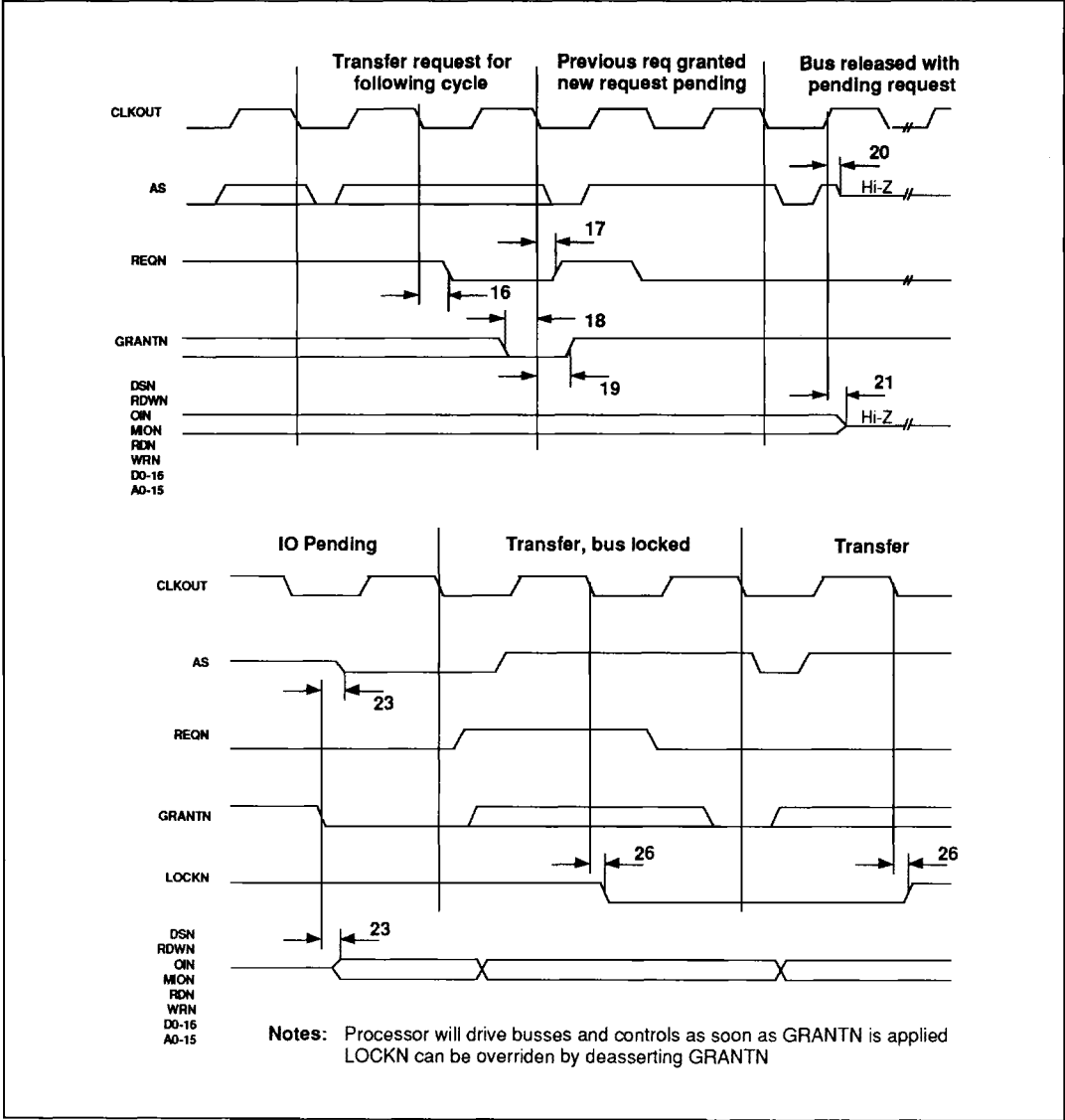

Figure 24: Bus Arbitration Timing

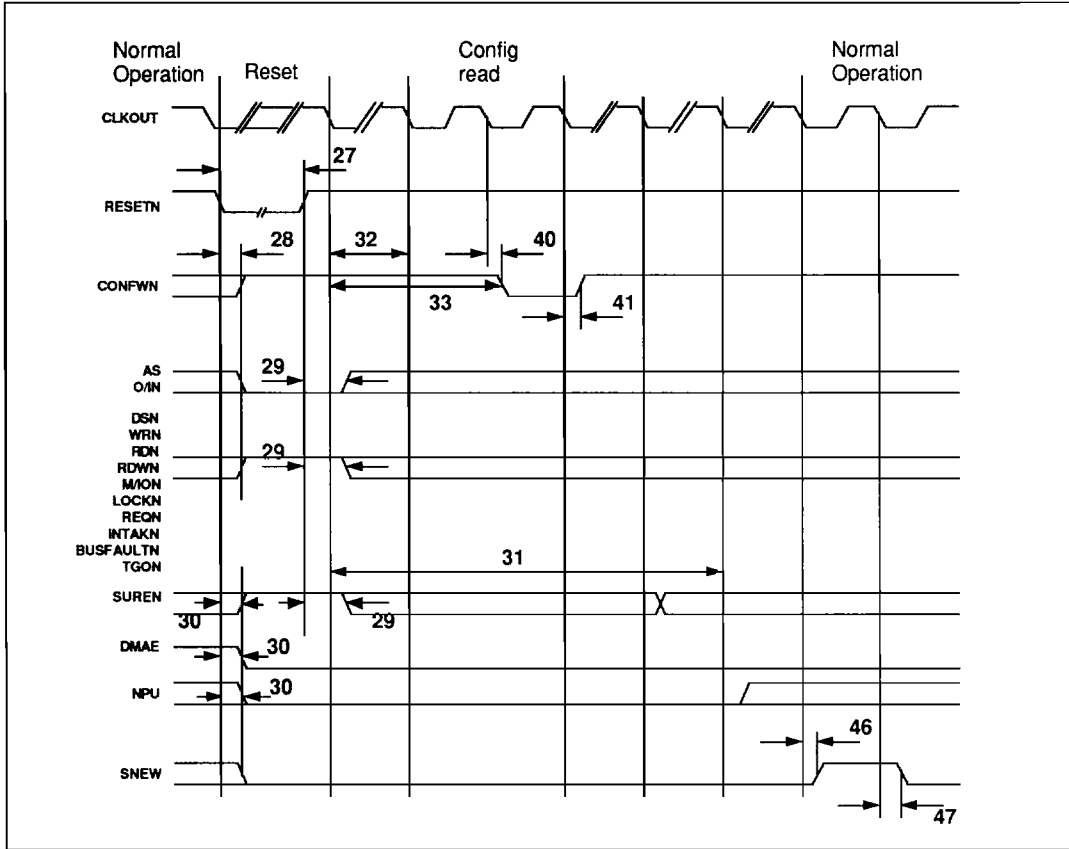

Figure 25: Reset Timing

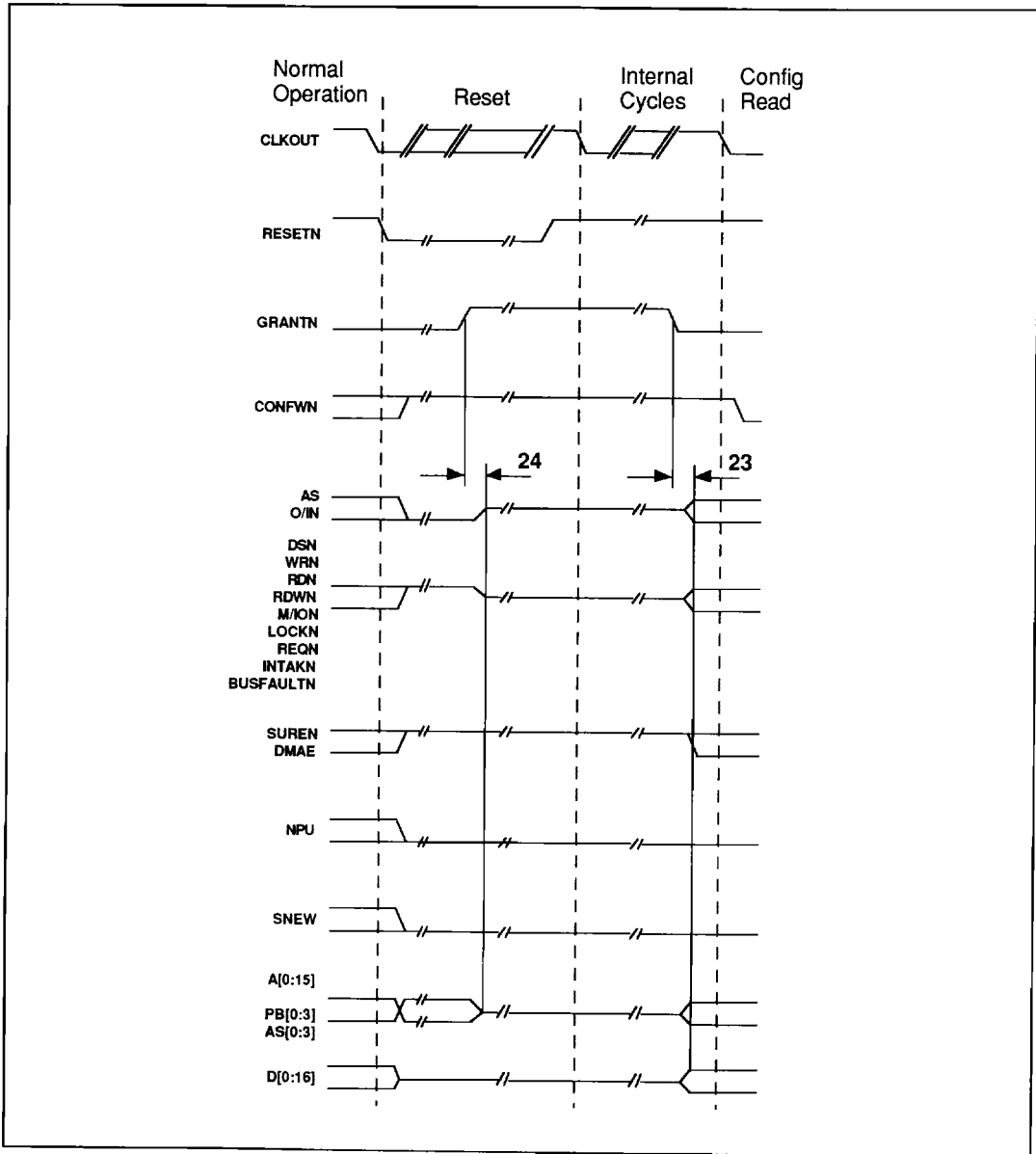

Figure 26: GRANTN during RESETN Low

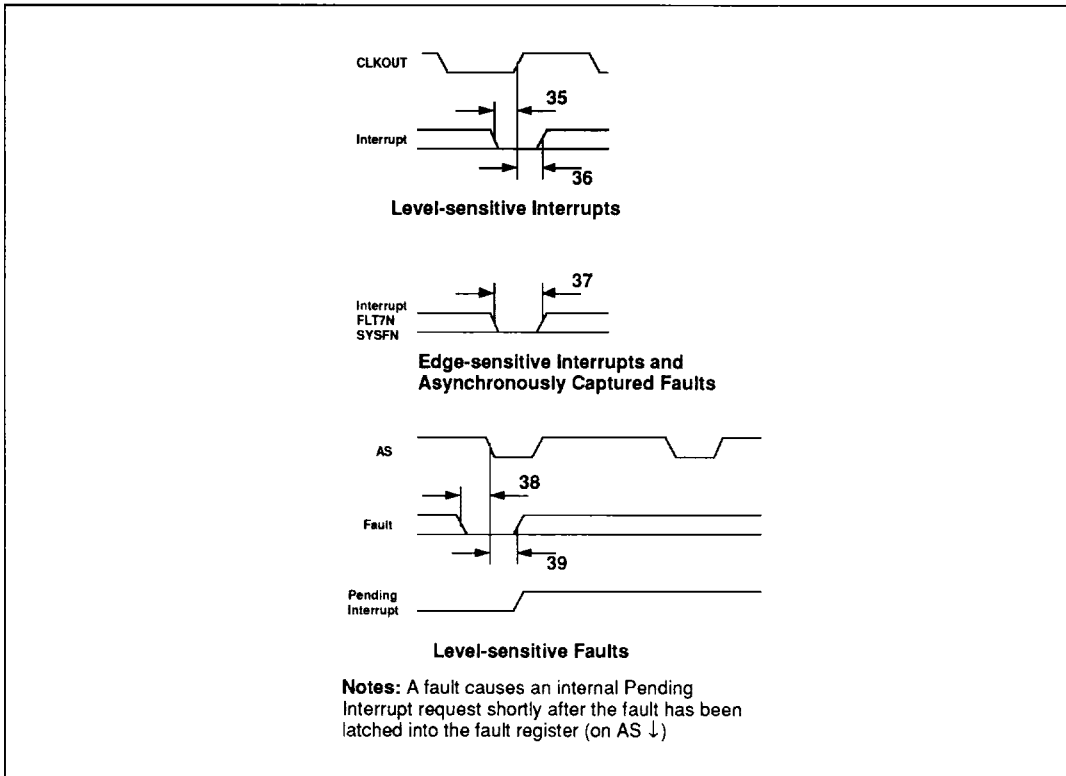

Figure 27: External Interrupt and Fault Timing

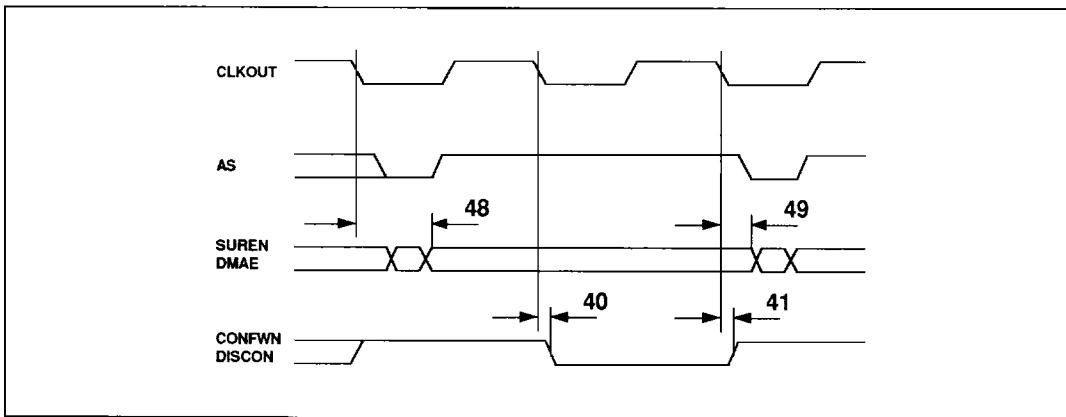

Figure 28: Discrete Timings

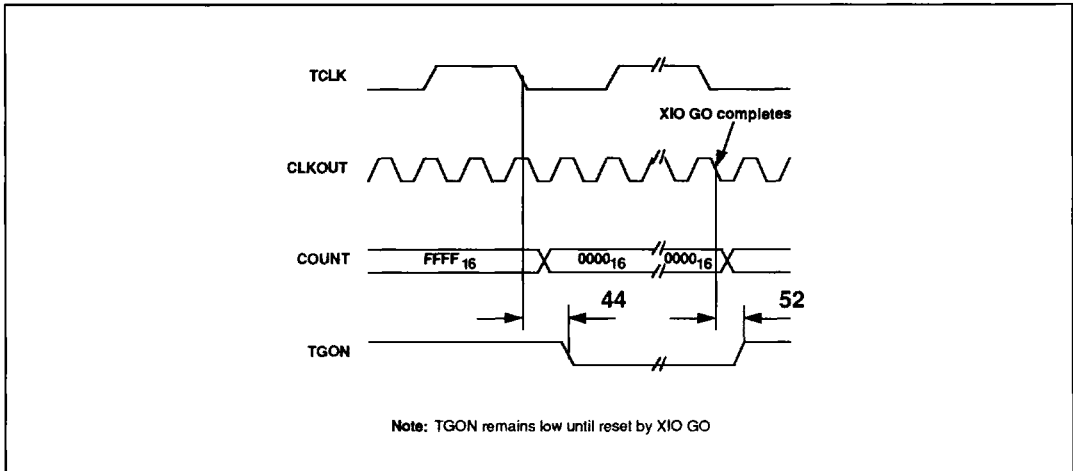

Figure 29: Trigger Go Timing

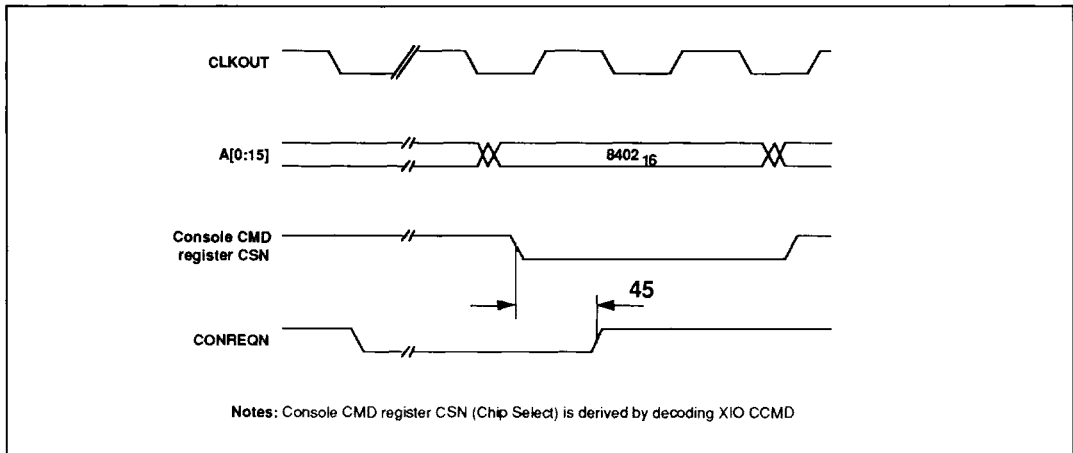

Figure 30: Console Request Timings

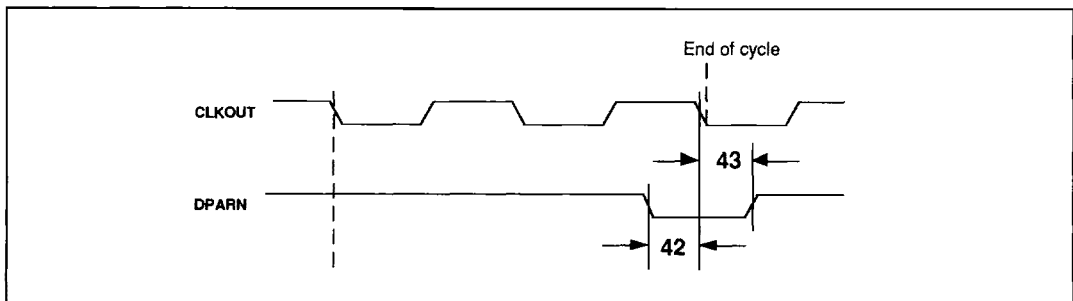

Figure 31: DPARN Timing

MA31750

No.	Parameter	Min.	Typ.	Max.	Units
1	ADDRESS valid to AS rising	TL-25	-	-	ns
2	ADDRESS valid after AS falling	5	-	25	ns
3	CLKOUT low to ADDRESS valid	-	-	40	ns
4	CLKOUT rising to AS rising	-	-	20	ns
5	CLKOUT falling to AS falling	-	-	15	ns
6	Data setup to RDN rising	15	-	-	ns
7	Data hold after RDN rising	0	-	-	ns
8	CLKOUT falling to DSN, RDN, WRN falling	-5	-	10	ns
9	CLKOUT falling to DSN, RDN, WRN rising	-5	-	10	ns
10	RDYN setup to CLKOUT falling	25	-	-	ns
11	RDYN hold after CLKOUT falling	0	-	-	ns
12	WRN falling to write data valid (Test Load 2)	10	15	25	ns
13	Write data valid after WRN rising (Test Load 2)	15	-	40	ns
14	DSN falling to data bus driven (Write)	-	15	30	ns
15	DSN rising to data bus hi-Z (write) (Test Load 2)	-	-	30	ns
16	CLKOUT falling to REQN falling	-	10	50	ns
17	CLKOUT falling to REQN rising	-	20	35	ns
18	GRANTN setup to CLKOUT falling	15	5	-	ns
19	GRANTN hold after CLKOUT falling	30	10	-	ns
20	CLKOUT rising to AS hi-Z (bus grant removed) (Test Load 2)	-	30	-	ns
21	CLKOUT rising to control lines and busses hi-Z (Test Load 2)	-	30	-	ns
23	GRANTN falling to control and busses driven (Test Load 2)	-	15	-	ns
24	GRANTN rising to strobes undriven (RESETN = LOW)	-	30	-	ns
26	CLKOUT falling to LOCKN valid	-	10	-	ns
27	RESETN low pulse width	50	-	-	ns
28	RESETN low to strobes inactive (GRANTN = LOW)	-	30	-	ns
29	RESETN high to strobes valid (GRANTN = LOW)	-	30	-	ns
30	RESETN falling to DMAE, NPU low, SUREN high	-	-	4	CLK
31	RESETN rising to DMAE, SUREN, NPU initialized	42	-	13500†	CLK
32	RESETN rising to first bus cycle (Configuration word read)	6	-	6	CLK
33	RESETN rising to CONFWN low	7	-	7	CLK
34	RESETN rising to first instruction fetch	T31+8	-	T31+8	CLK
35	Interrupt setup to CLKOUT rising (level sensitive)	0	-5	-	ns
36	Interrupt hold after CLKOUT rising (level sensitive)	-	8	-	ns
37	Interrupt pulse width (edge-sensitive)	15	-	-	ns
38	Fault setup to AS falling	30	-	-	ns
39	Fault hold after AS falling	15	8	-	ns
40	CLKOUT falling to CONFWN, DISCON low	-	15	-	ns
41	CLKOUT falling to CONFWN, DISCON high	0	10	-	ns
42	DPARN setup to CLKOUT falling	-	25	-	ns
43	DPARN hold after CLKOUT falling	-	10	-	ns
44	TCLK falling to TGON low	-	20	-	ns
45	CONREQN hold after Console Command Chip Selection	-	-	3	CLK
46	CLKOUT falling to SNEW rising	-	15	-	ns
47	CLKOUT falling to SNEW falling	-	15	-	ns
48	CLKOUT falling to SUREN/DMAE valid	-	15	25	ns
49	CLKOUT falling to SUREN/DMAE invalid	-	15	25	ns
50	MPROEN/EXADEN setup to CLKOUT falling	-	20	-	ns
51	MPROEN/EXADEN hold after CLKOUT falling	-	10	-	ns
52	CLKOUT falling to TGON rising (following XIO GO)	-	20	-	ns
53	AS low pulse width	0.5T-5	-	0.5T+10	ns
54	AS falling to BUSFAULTN valid	-	-	-	ns

† This timing includes MA31751 setup cycles and Built In Test cycles
 Mil-Std-883, method 5005, subgroups 9, 10, 11

Note: TL=Low CLK period (ns), TH = High CLK period (ns)

Test Conditions: Vdd=5.0V ±10%, Temperature = -55°C to 125°C, Vil=0.0V, Vih=Vdd

Output loads: All test load 1 unless otherwise specified

Output Threshold: 50% Vdd (Load 1), Vss+1V, Vdd-1V (load2)

Figure 32a: Timing Parameters for MA31750

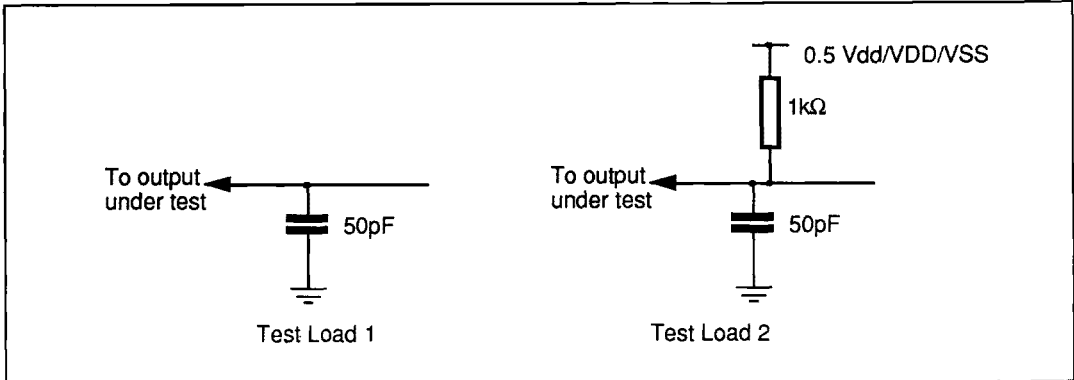

Figure 32b : Output Loads for AC measurements

8. TYPICAL SMALL SYSTEM CONFIGURATION

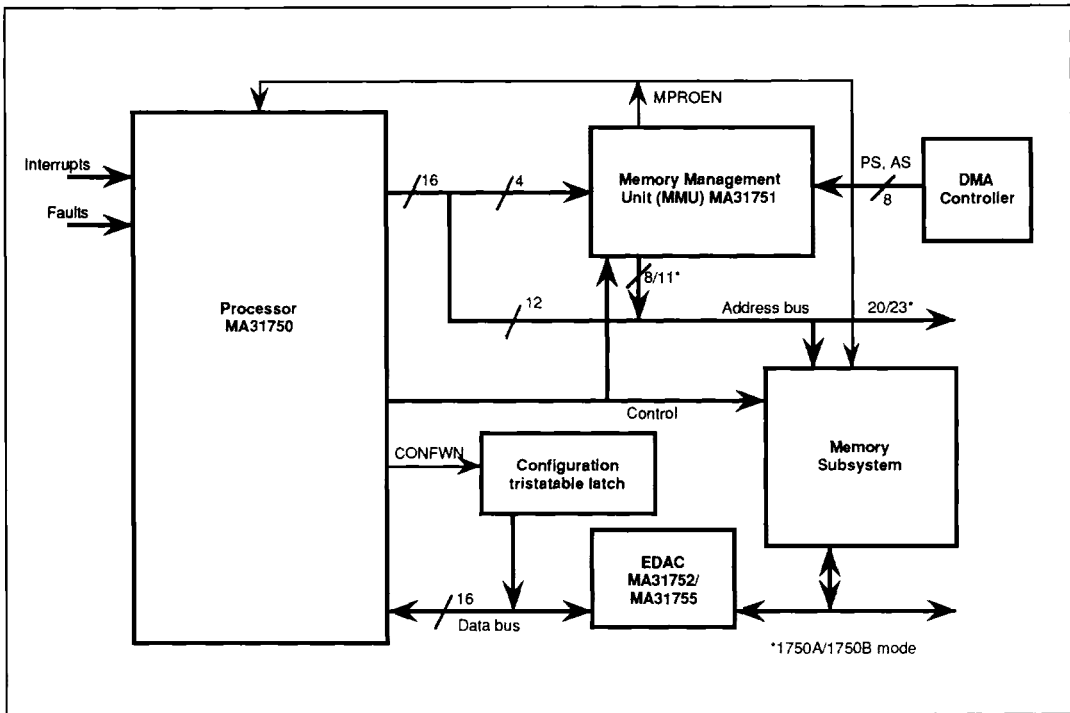

Figure 33: Typical Small System Configuration

A Single Board Computer is available to developers. Please call GPS for details.

MA31750

9. RATING AND CHARACTERISTICS

Parameter	Min.	Max.	Units
Supply voltage	-0.5	7	V
Input voltage	-0.3	VDD+0.3	V
Current through any I/O pin	-20	20	mA
Operating temperature	-55	125	°C
Storage temperature	-65	150	°C

Note: Stresses above those listed may cause permanent damage to the device. This is a stress rating only and functional operation of the device at these conditions, or at any other condition above those indicated in the operations section of this specification, is not implied. Exposure to absolute maximum ratings for extended periods may affect device reliability.

Figure 34: Absolute Maximum Ratings

Parameter	Min.	Max	Units
Clock Frequency (CLK)	0	12/16	MHz
TCLK Frequency	0	†CLK / 9 †	Hz
Recommended Clock duty cycle	45	55	%

† MIL-STD-1750 mandates that TCLK be 100kHz
 Vdd=5V±10% over full operating temperature range
 Mil-Std-883, method 5005, subgroups 7, 8A, 8B

Figure 35: Operating AC Electrical Characteristics

Symbol	Parameters	Conditions	Total dose radiation not exceeding 3x10 ⁵ Rad(Si)			Total dose radiation not exceeding 1MRad(Si)		
			Min	Typ	Max	Min	Max	Units
V _{DD}	Supply Voltage	-	4.5	5.0	5.5	4.5	5.5	V
V _{IH}	Input high voltage	-	80% V _{DD}	-	-	80% V _{DD}	-	V
V _{IL}	Input low voltage	-	-	-	20% V _{DD}	-	20% V _{DD}	V
V _{CKH}	CLK & TCLK input high voltage	-	V _{DD} -0.5	-	-	V _{DD} -0.5	-	V
V _{CKL}	CLK & TCLK input low voltage	-	-	-	V _{SS} +0.5	-	V _{SS} +0.5	V
V _{OH}	Output high voltage	I _{OH} =-5mA	V _{DD} -0.5	-	-	V _{DD} -0.5	-	V
V _{OL}	Output low voltage	I _{OL} = 5mA	-	-	V _{SS} +0.4	-	V _{SS} +0.4	V
I _{IH}	Input high current (Note 1)	-	-	-	10	-	100	µA
I _{IL}	Input low current (Note 1)	-	-	-	-10	-	-100	µA
I _{OZH}	I/O tristate high current (Note 1)	-	-	-	50	-	300	µA
I _{OZL}	I/O tristate low current (Note 1)	-	-	-	-50	-	-300	µA
I _{DDYN}	Dynamic supply current @ 22MHz	-	-	-	110	-	190	mA
I _{DDS}	Static supply current	-	-	-	10	-	10	mA

Vdd=5V±10% over full operating temperature range
 Mil-Std-883, method 5005, subgroups 1, 2, 3
 Note 1: Guaranteed but not tested at low temperature (-55°C)

Figure 36: Operating DC Electrical Characteristics

Subgroup	Definition
1	Static characteristics specified in Table 35 at +25°C
2	Static characteristics specified in Table 35 at +125°C
3	Static characteristics specified in Table 35 at -55°C
7	Functional characteristics specified in Table 34 at +25°C
8A	Functional characteristics specified in Table 34 at +125°C
8B	Functional characteristics specified in Table 34 at -55°C
9	Switching characteristics specified in Table 31a at +25°C
10	Switching characteristics specified in Table 31a at +125°C
11	Switching characteristics specified in Table 31a at -55°C

Figure 37: Definition of MIL-STD-883, Method 5005 Subgroups

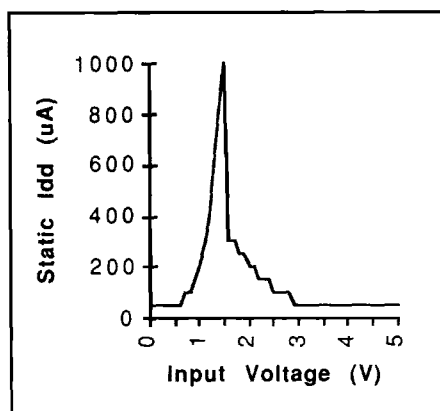

Figure 38: Input Characteristic

10. PIN DESCRIPTIONS

A description of each pin function appears in Figure 39. The acronym is presented first, followed by its function and description. Timing characteristics of each of the functions are shown in section 6.

All signals - with the exception of CLK and TCLK are CMOS compatible, and are protected by an Electrostatic Discharge (ESD) protection circuit. All output signals are also TTL compatible. CLK and TCLK are Schmitt inputs.

Throughout this data sheet, active low signals are denoted by following the signal name with an "N" suffix, e.g., DSN. If a signal has a dual function, both function names will be used separated by a "/". The function name to the left of the "/" will be active high while the function to the right will be active low, again with an "N" suffix, e.g., RD/WN.

All unused inputs should be connected to their inactive state and should not be allowed to float.

MA31750

Pin Name	Function	Description
----------	----------	-------------

POWER

VDD	Power Supply	DC power supply input - nominally +5V.
GND	Ground	0V reference point.

CLOCK SIGNALS

CLK	System Clock	Schmitt Input clock signal. For correct operation of the timers the CLK frequency should be at least 8 times that of TCLK.
CLKOUT	Clock Out	Buffered reference clock derived directly from the internal clock. This signal is used to reference all of the external strobes and internal timing events and may be used to synchronise an external system to the processor.
TCLK	Timer Clock <i>100kHz sq. wave</i>	This Schmitt input clock is used by the internal 16-bit timers A and B and by the Trigger-Go-counter. MIL-STD-1750 requires this signal to have a frequency of 100kHz.

SYSTEM BUSES

A00-A15	Address bus <i>A00 is MSB</i>	An active-high address bus which is tristate during bus cycles not assigned to this CPU. A00 is the most significant bit.
D00-D16	Data bus <i>D00 is MSB</i>	An active-high data bus which is tristate during bus cycles not assigned to this CPU. D00 is the most significant bit. D16 is the optional parity check bit.

BUS CONTROL

AS	Address Strobe <i>Active HIGH</i>	This active-high bidirectional signal establishes the beginning and end of each bus cycle. The trailing edge (high to low transition) is used to sample bus cycle-related faults into the fault register. The leading edge guarantees that a valid address is on the address bus. During cycles not assigned to this CPU the AS line is an input to allow the falling edge to continue to latch bus cycle related faults into the fault register.
DSN	Data Strobe <i>Active LOW</i>	This active-low signal indicates the presence of data on the system data bus. During a read cycle DSN goes low to indicate that the processor is requesting data from the bus, whilst in a write cycle DSN indicates that data is present on the bus. This signal is tristate in bus cycles not assigned to this CPU.
M/ION	Memory/IO Select <i>Memory=HIGH IO=LOW</i>	This signal indicates whether the current bus cycle is accessing memory (high) or IO (low) addressing space. This signal becomes valid shortly after the start of a machine cycle and remains valid throughout. M/ION becomes an input on cycles not assigned to the CPU to ensure that faults are latched into the correct bit of the fault register.
RD/WN	Read/Write Select. <i>Read=HIGH Write=LOW</i>	This signal indicates the direction of data transfer on the system data bus. Data is read in by the processor when high, and written out when low. This signal becomes valid shortly after the start of a machine cycle and remains valid throughout. RD/WN is tristate during cycles not assigned to this CPU.
O/IN	Operand/Instruction Select. <i>Operand=HIGH Instr.=LOW</i>	This signal indicates whether the current bus cycle is accessing operand (high) or instruction (low) addressing space. This signal becomes valid shortly after the start of a machine cycle and remains valid throughout. O/IN is an input during cycles not assigned to this CPU, to ensure correct operation of the MFPR and the MFAR.
RDN	Read Strobe. <i>Active LOW</i>	This active-low output is asserted low with DSN during read cycles. It is driven high on the same clock edge as that used by the processor to latch the input data. This signal is tristate in bus cycles not assigned to this CPU.
WRN	Write Strobe. <i>Active LOW</i>	This active-low output signal is asserted low with DSN during write cycles. The rising edge should be used by the system to latch data from the data bus. This signal is tristate in bus cycles not assigned to this CPU.
RDYN	Ready. <i>Active LOW</i>	This input signal allows the basic machine cycle of the processor to be extended to accommodate slower peripheral or memory devices. Ready may be asserted high to add an integer number of CLK cycles (wait states) to the machine cycle. The line must be asserted low to allow processing to proceed. RDYN has no effect on cycles dedicated to internal operations. Note: If RDYN is held high during two consecutive TCLK high-to-low transitions (with DSN low), a bus timeout fault will occur and will be indicated in the appropriate bit in the fault register. The occurrence of this fault will cause the state sequencer to terminate the current machine cycle and begin the next. At the end of the current macro-instruction execution will branch, unless masked, to the machine error interrupt (level 1) software routine. The DTON signal may be used to override this feature.

Figure 39: Pin Descriptions

Pin Name	Function	Description
----------	----------	-------------

BUS ARBITRATION

LOCKN	Bus Lock Request. <i>Active LOW</i>	This active-low output signal indicates to the bus arbiter that the processor is performing an atomic instruction which should not be interrupted. External bus accesses should be denied whilst LOCKN is low. The CPU will lock the bus during read-modify-write instructions such as DECM (Decrement Memory) and TSB (Test & Set Bit). LOCKN remains high during non-locked cycles. Note: LOCKN is advisory only - it may be ignored by the arbiter if necessary.
REQN	Bus Request. <i>Active LOW</i>	This active-low output signal is driven low when the CPU requires the bus in the next cycle. An external arbiter should sample this signal at the third clock edge in a machine cycle. The signal becomes invalid once the CPU has started the requested cycle.
GRANTN	Bus Grant. <i>Active LOW</i>	This active-low signal is asserted by an external bus arbiter to indicate that the CPU currently has the highest priority bus request. The CPU will begin a bus cycle (if one is pending) commencing with the next CPU clock cycle.

INTERRUPTS

PWRDN	Power-Down Interrupt. <i>Active LOW</i>	A low on this active low input will be captured in the PI register and sets Pending Interrupt 0. This is the highest priority interrupt and cannot be masked or disabled.
INT02N, INT08N, INT10N, INT11N, INT13N, INT15N	Interrupt Inputs. <i>Active LOW</i>	A low on any of these active low inputs will be captured in the PI register and will set Pending Interrupt levels 2, 8, 10, 11, 13, and 15, respectively. Level 2 is the highest priority user level, while level 15 is the lowest priority. These interrupts are maskable and can be disabled. If edge sensitivity has been selected, interrupts will be captured on the falling edge of the interrupt input, otherwise the interrupt will be latched by the falling edge of CLK at the end of the machine cycle. Note: Interrupt levels 1, 3, 4, 5, 6, 7 and 9 are dedicated to internal machine interrupts.
IOI1N, IOI2N		A low on either input will set Pending Interrupt levels 12 or 14 respectively. These inputs are level sensitive only and are captured by the falling edge of CLK at the end of a machine cycle. These inputs can be masked and disabled.
INTAKN	Interrupt Acknowledge Strobe. <i>Active LOW</i>	This active-low output indicates the start of an interrupt service. When low, the processor outputs the Linkage Pointer (LP) address to the system. The INTAKN signal may be used to remove level-sensitive interrupt inputs: the current interrupt priority can be ascertained by reading the address bus during the cycle in which this output is low.

FAULTS

MPROEN	Memory Protect Fault. <i>Active LOW</i>	A low on this input, sampled on falling AS, indicates that an execute protect or write protect fault has been detected. Bit 0 of the fault register is set if this signal is applied during a CPU cycle; bit 1 is set if the line goes low during a DMA cycle. Either condition sets Pending Interrupt level 1. The CPU will prevent access to memory (by inhibiting strobe production) whilst this input is LOW. See 3.4.7.1. To effectively use this feature, MPROEN should be pulled low prior to the start of the next machine cycle.
PEN	Parity Error <i>Active LOW</i>	A low on this active-low input, sampled on falling AS, informs the CPU that an external parity error has occurred. Bit 2 (memory), 3 (IO) or 4 (DMA) of the Fault Register is set, depending upon the type of transfer taking place. This asserts a level 1 Pending Interrupt.
EXADEN	External Address Error <i>Active LOW</i>	A low on this active-low input, sampled on falling AS, informs the CPU that an external address error has occurred. Bit 8 of the fault register is set if this signal goes low during a memory cycle; bit 5 is set if the signal goes low during an IO cycle. Either error condition asserts a level 1 pending interrupt. As with MPROEN, the CPU will prevent access to memory (by inhibiting strobe production) whilst this input is LOW. See 3.4.7.1
FLT7N	Fault Level 7 <i>Active LOW</i>	A low at any time on this active-low input sets bit 7 of the fault register, causing a level 1 pending interrupt. This fault is user-definable.
SYSFN	System Fault <i>Active LOW</i>	A low at any time on this active-low input sets bits 13 and 15 of the fault register, causing a level 1 pending interrupt. This fault is user definable.
BUSFAULTN	Illegal address <i>Active LOW</i>	This active-low output drops low if any bus-related fault is detected low or if the bus fault timeout circuit causes an interface timeout.

Figure 39 (continued): Pin Descriptions

MA31750

Pin Name	Function	Description
MMU CONTROL		
AS[0:3]	Address State Active HIGH <i>AS0 is MSB</i>	This active-high bus indicates the current address state of the CPU. The value on this bus is copied from the Status Word register within the CPU. These lines are inputs during bus cycles not assigned to this CPU, so that the MFPR and the MFAR can store the relevant failure information if a remote failure occurs.
PB[0:3]	Page Bank Select Active HIGH <i>PB0 is MSB</i>	In 1750B mode, this active-high bus indicates the current CPU Page Bank. The value on this bus is copied from the Status Word register within the CPU. These lines are inputs during bus cycles not assigned to this CPU, so that the MFPR and the MFAR can store the relevant failure information if a remote failure occurs.

DISCRETES

CONFVN	Configuration Register Read Strobe Active LOW	This active-low output signal is driven low when the processor reads the external configuration register. The line may be used as an output enable for this register. The configuration register is read during initialisation and during the execution of a BPT instruction to determine the system configuration.
SNEW	Start of New Cycle Strobe Active HIGH	This active-high output will be asserted high during the first phase of each machine cycle.
DISCON	Discreted Output Strobe Active LOW	This active-low output will be asserted low by the processor during an XIO OD or XIO RDOR command. It may be used as the enable signal for an external discrete output register.
DMAE	DMA Enable Active HIGH	This active-high output indicates that an external DMA device is enabled. It is disabled (low) following reset and can be toggled under program control using XIO DMAE and XIO DMAD, (if a DMA device is set as present in the configuration register).
CONREQN	Console Request Active LOW	This active-low input initiates and controls Console operation following the end of a 1750 instruction. Commands and data are passed to the processor in this mode via three dedicated registers in IO space. Console operation takes precedence over Interrupts.
SUREN	Start-Up-ROM Enable Active LOW	This active-low output indicates that start-up ROM is enabled. The signal is asserted low following initialisation or by XIO ESUR. The signal remains asserted until removed with XIO DSUR. When a start-up ROM is present on the system indicated in the configuration word, this signal should be used to qualify its chip select or output enable such that the ROM may be accessed only when SUREN is low. Note: Instruction pipelining must be considered in moving from Start-Up ROM to RAM. See Section 4 on Software Considerations.
NPU	Normal Power-Up Discrete Active HIGH	This output is asserted to indicate that the Built-In-Test (BIT), performed on reset or power-up, has passed. The line is asserted low following an external reset and may also be reset by software using the XIO RNS command.
TGON	Trigger-Go Output Discrete Active LOW	This active-low output is asserted low whenever the Trigger-Go counter overflows (rolls over to 0000). It returns to the high state when the counter is reset by software (using the XIO GO command).
DTON	Disable Timeout Active LOW	A low on this input will reset and disable the bus fault timeout circuit.
DPARN	Disable Parity Active LOW	A low on this input will reset and disable the on-chip parity verification. Note: Parity <i>generation</i> on write data is not disabled by this pin.
RESETN	CPU reset <i>Reset=LOW</i>	This active-low input should be asserted low to reset the processor. The low to high transition will start the initialisation sequence which will perform a Built-In-Test (if selected), initialising the processor in accordance with MIL-STD-1750 (see figures 2 and 3).

Figure 39 (continued): Pin Descriptions

11. PIN ASSIGNMENTS AND OUTLINES

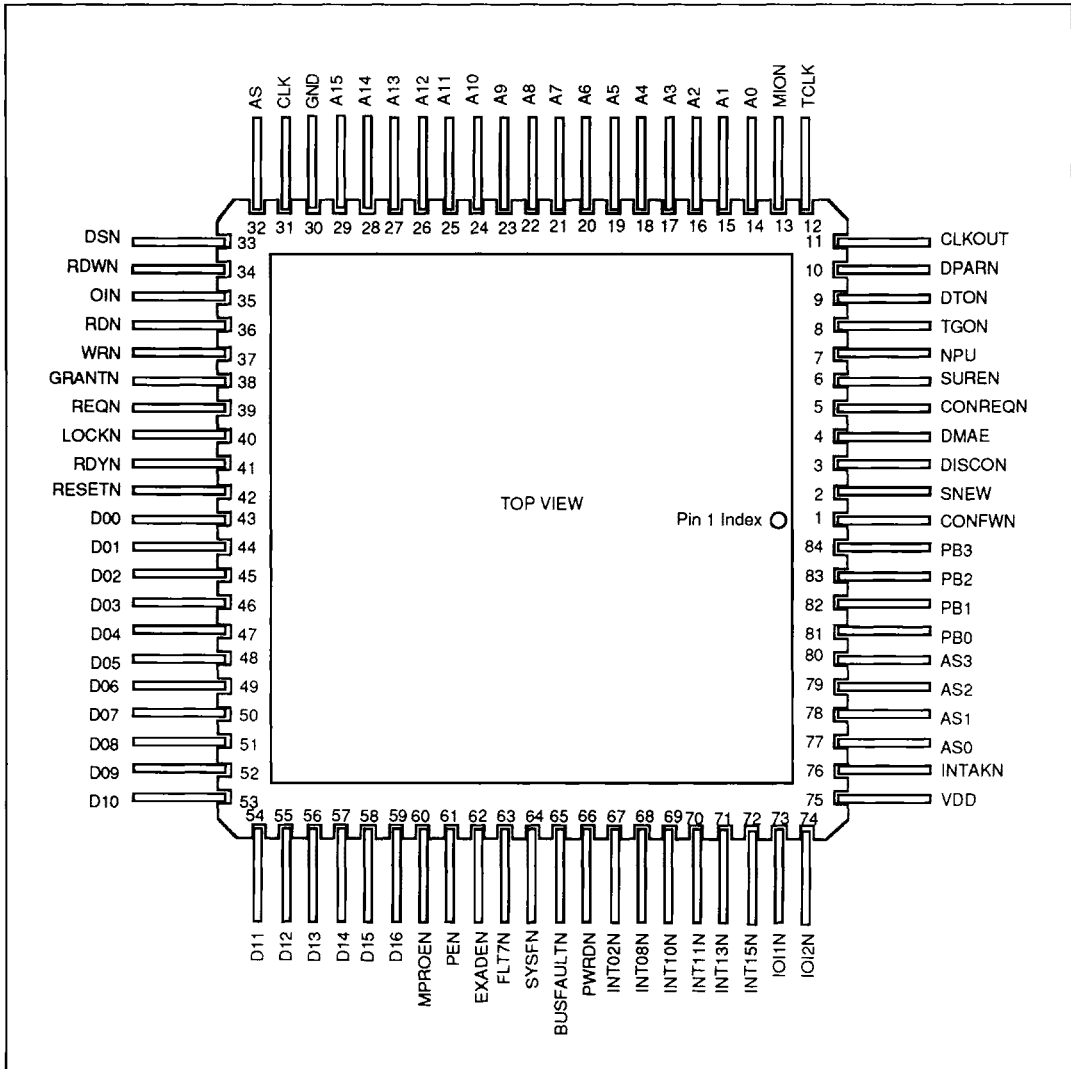
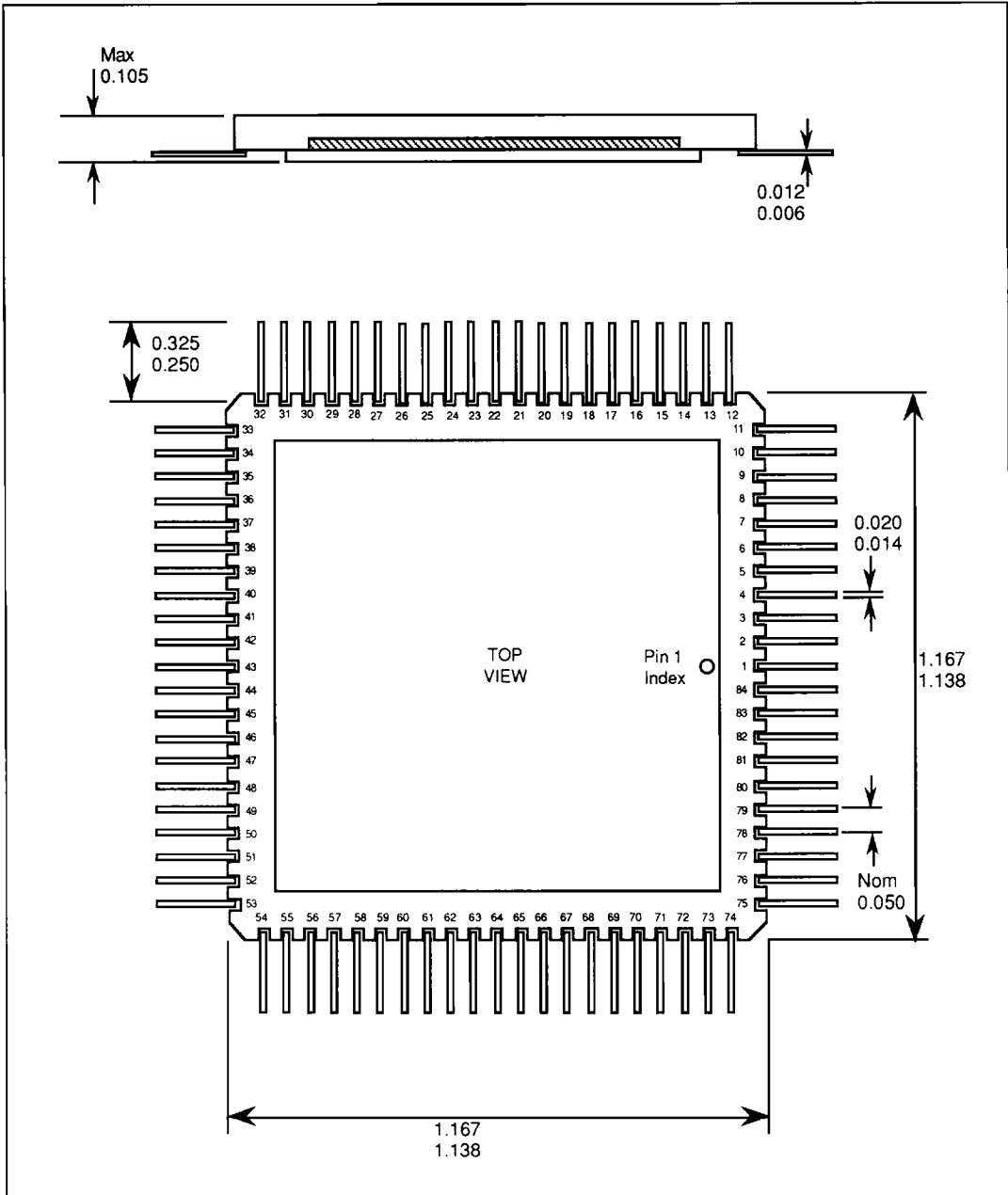

Figure 40a: 84-Lead Flatpack - Package Style F

MA31750



NOTE: All dimensions shown in inches

Figure 40b: 84-Lead Flatpack - Package Style F

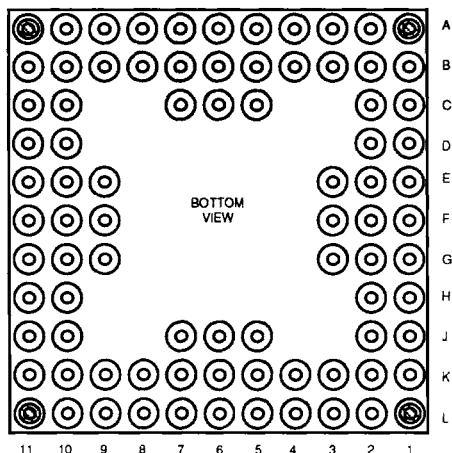

A1	IOI2N	B11	D08	F9	D00	K2	TCLK
A2	INT15N	C1	AS1	F10	RESETN	K3	MION
A3	INT13N	C2	INTAKN	F11	D04	K4	A02
A4	INT10N	C5	BUSFAULTN	G1	DISCON	K5	A05
A5	PWRDN	C6	SYSFN	G2	DMAE	K6	A04
A6	INT08N	C7	MPROEN	G3	CONREQN	K7	A11
A7	EXADEN	C10	D09	G9	REQN	K8	A14
A8	D16	C11	D07	G10	LOCKN	K9	CLK
A9	D14	D1	AS3	G11	RDYN	K10	DSN
A10	D13	D2	AS2	H1	SUREN	K11	OIN
A11	D10	D10	D06	H2	NPU	L1	CLKOUT
B1	AS0	D11	D05	H10	WRN	L2	A00
B2	VDD	E1	PB2	H11	GRANTN	L3	A01
B3	IOI1N	E2	PB1	J1	TGON	L4	A03
B4	INT11N	E3	PB3	J2	DPARN	L5	A06
B5	INT02N	E9	D01	J5	A07	L6	A09
B6	FLT7N	E10	D03	J6	A08	L7	A10
B7	PEN	E11	D02	J7	A12	L8	A13
B8	D15	F1	SNEW	J10	RDWN	L9	A15
B9	D12	F2	PB0	J11	RDN	L10	GND
B10	D11	F3	CONFWN	K1	DTON	L11	AS

Figure 41a: 84-Pin Grid Array - Package Style A

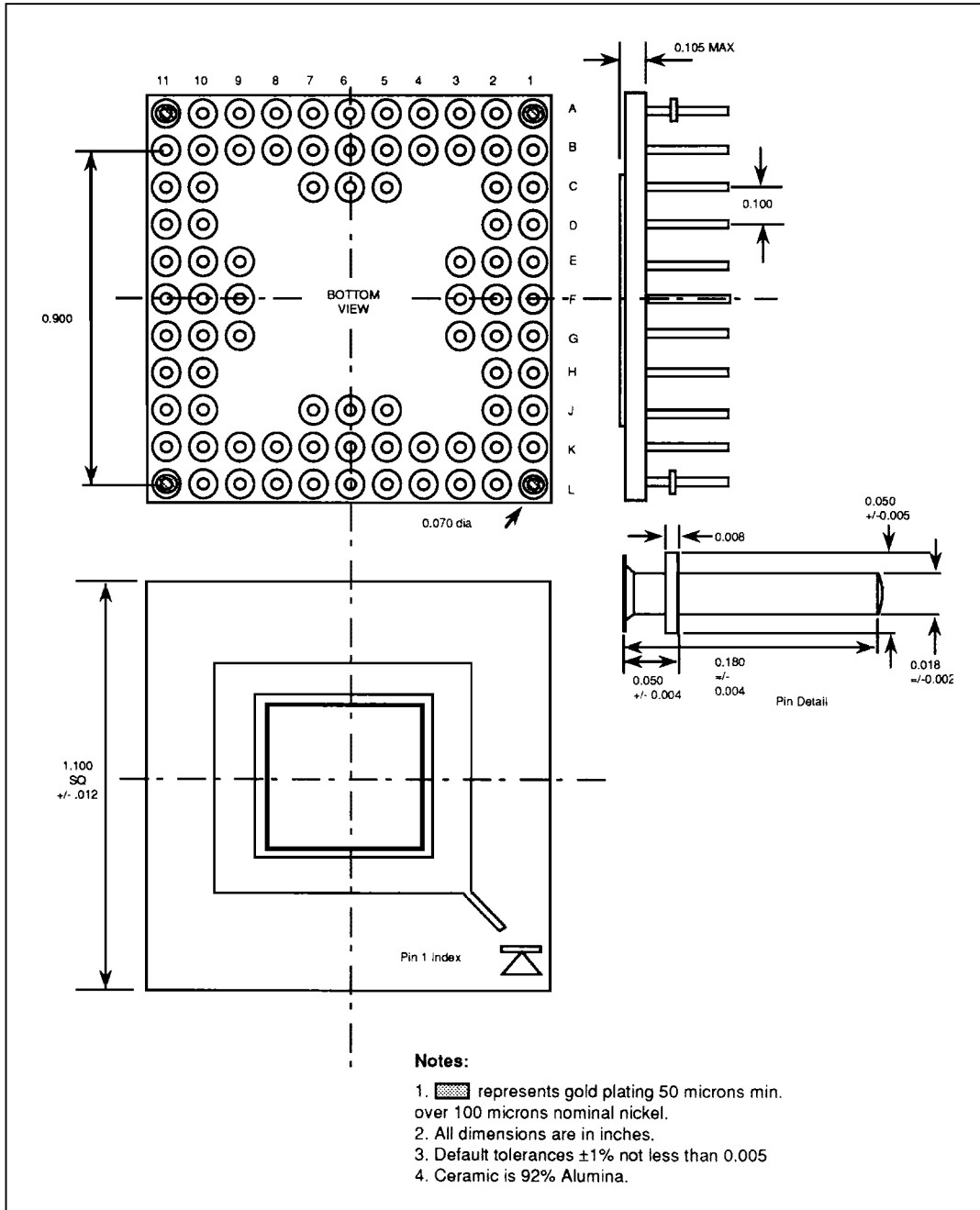

Figure 41b: 84-Pin Grid Array - Package Style A

12. RADIATION TOLERANCE

Total Dose Radiation Testing

For product procured to total dose radiation levels, each wafer lot will be approved when all sample devices pass the total dose radiation test.

The sample devices will be subjected to the total dose radiation level (Cobalt-60 Source), defined by the ordering code, and must continue to meet the electrical parameters specified in the data sheet. Electrical tests, pre and post irradiation, will be read and recorded.

GEC Plessey Semiconductors can provide radiation testing compliant with MIL STD 883 test method 1019, Ionizing Radiation (Total Dose).

Total Dose (Function to specification)	1×10^6 Rad(Si)
Transient Upset (Stored data loss)	3×10^{11} Rad(Si)/sec
Transient Upset (Survivability)	$> 1 \times 10^{12}$ Rad(Si)/sec
Neutron Hardness (Function to specification)	1×10^{15} neutrons/cm ²
Single Event Upset (GSO 10% worst case)	$< 1 \times 10^{-10}$ errors/bitday
Latch-up	Not possible

Figure 42: Radiation Hardness Parameters

13. RELATED DOCUMENTATION

A number of Applications Notes are available to support the information in this data sheets. Please call for details:

Application Note	Describes
No. 2	1750B Mode
No. 3	Use of Console Mode
No. 4	Use of Interrupts
No. 8	Use of VIO Instructions
No. 11	Bus Arbitration

MA31750

14. ORDERING INFORMATION

