

SYMBOL DEFINITION	
A DIMENSION WITHOUT AN INSPECTION REPORT SYMBOL () DOES NOT REQUIRE INSPECTION. IT MAY BE CONTROLLED ON THE INDIVIDUAL COMPONENT DRAWING.	TOTAL NO OF INSPECTIONS REQUIRED
	17
	LAST NO. USED
	16

DATE	DWG STATUS				ZONE	REVISION HISTORY	AUTH	DR	APVD 1	APVD 2
	STG	REV	N/P	CHG						
28AU03	R	01	-	-		WAS PE057920 AND RELEASED	245105	ADK	ADK	RP
02AU04	R	02	-	-		MAT'L SPEC WAS M3592018	257547	TLD	TLD	RP

MISSING SYMBOLS
NO MISSING SYMBOL NUMBER

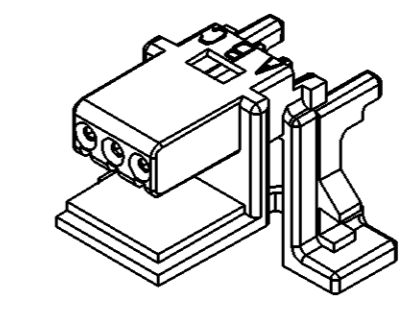
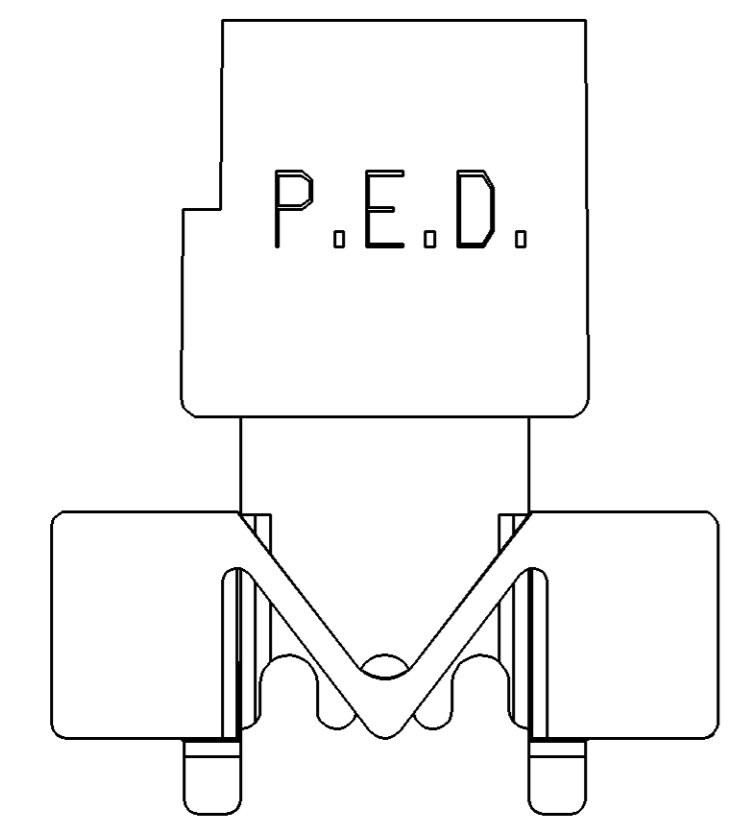
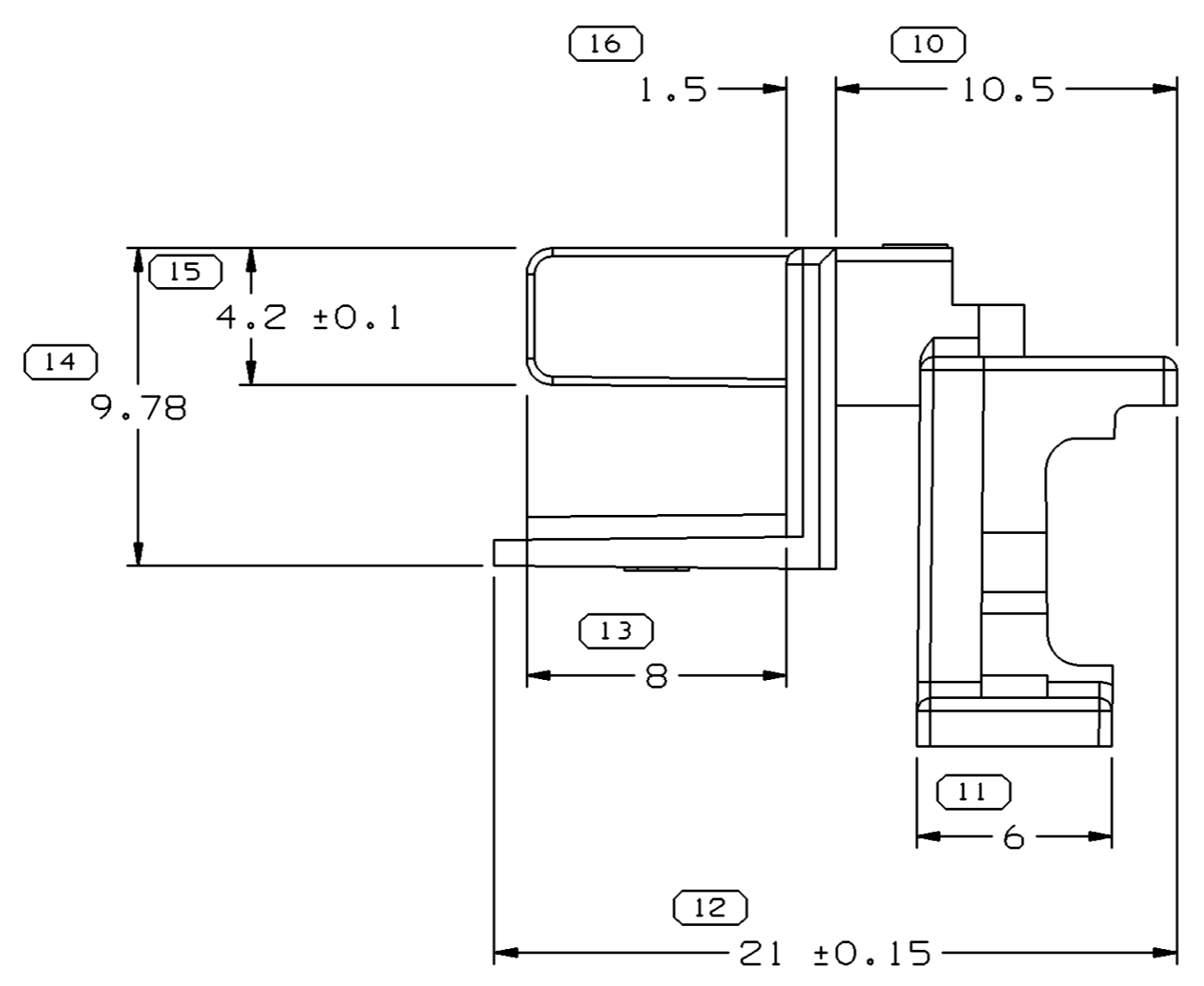
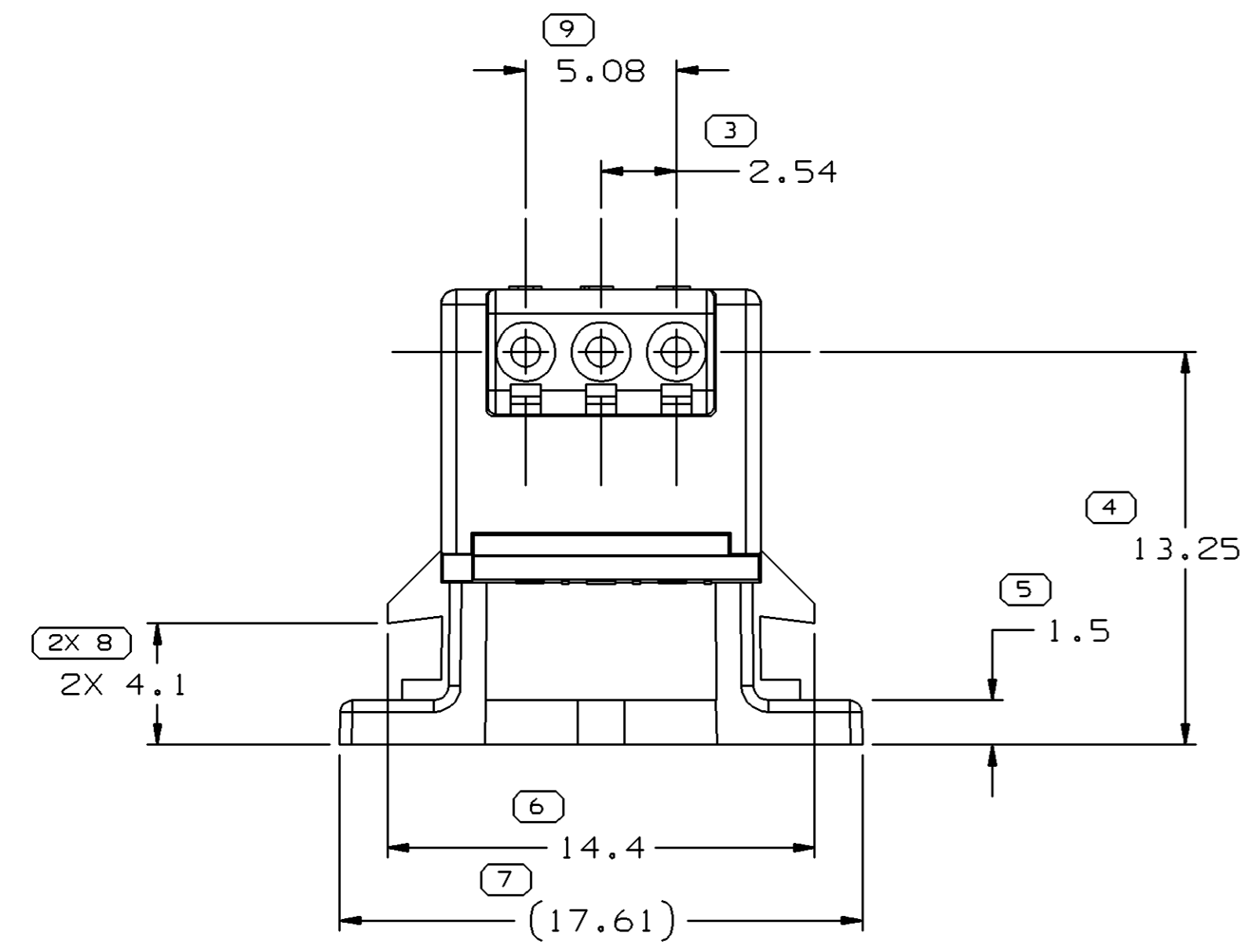
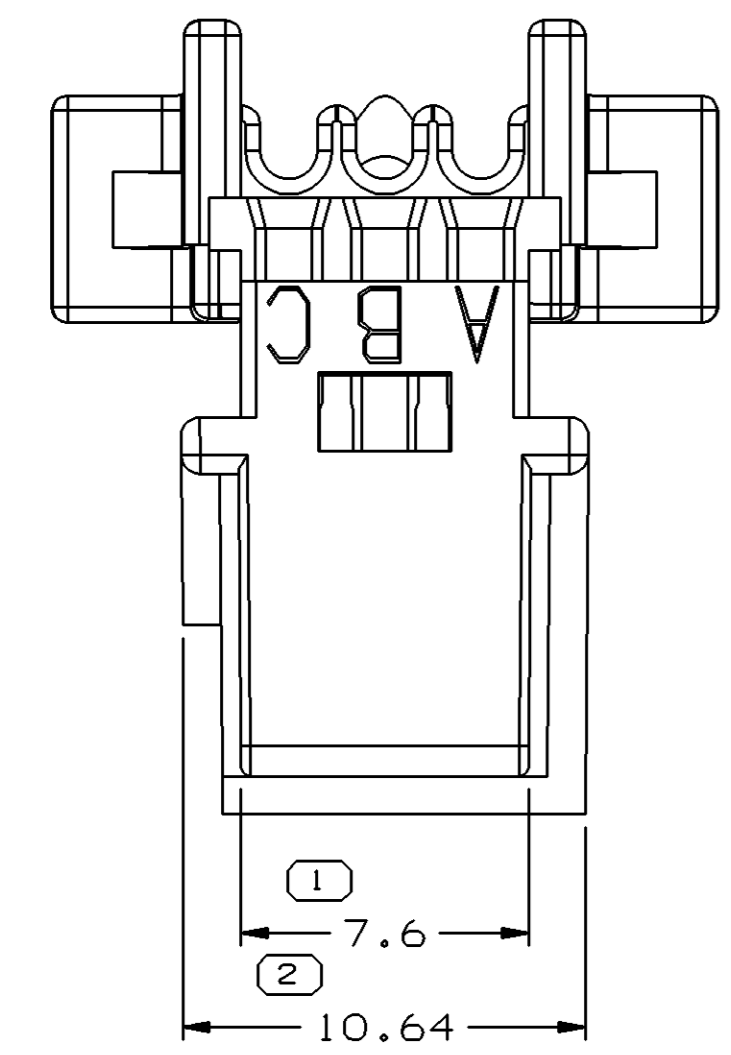

NOTES

- UNLESS OTHERWISE SPECIFIED AND/OR INDICATED: DIMENSIONS ARE TO FACE OF VIEW SHOWN AND AUTOMATICALLY ROUNDED BY COMPUTER FOR INSPECTION (SEE MATH MODEL FOR PRECISE DIMENSIONS). FOR ALL OTHER DIMENSIONS NOT SHOWN BUT REQUIRED FOR TOOL BUILD, SEE MATH MODEL FOR PRECISE TOOL PATH DATA.
- MATING COMPONENTS OR EQUIVALENT:
TERMINAL 12129361
TERMINAL POSITION ASSURANCE 12191748

N/A PROCESS SENSITIVE DIMENSION	
DIMENSIONS ENCLOSED IN () INDICATE REFERENCE DIMENSIONS AND NO TOLERANCE LIMITS ARE ESTABLISHED	
DIMENSIONAL RANGE (MM)	CHART E1
FROM > 0	> 20
TO 20	30
	70
	100
	150
	200
	250
	300
	400
TOLERANCE UNLESS OTHERWISE SPECIFIED	
±0.15	±0.2
±0.3	±0.4
±0.5	±0.6
±0.8	±1
±1.2	
ANGULAR TOLERANCE ±2°	

DWG TYPE	PART DRAWING
STYLE	
VOLUME (CM³)	0.769
DISTR CODE	D
UNLESS OTHERWISE SPECIFIED	
THIS DOCUMENT IS IN ACCORDANCE WITH ASME Y14.5M-1994 AS AMENDED BY THE GM GLOBAL DIMENSIONING AND TOLERANCING ADDENDUM - 1997. ALL GEOMETRIC TOLERANCES AND RELATED DATUMS APPLY RFS. RULE #1 PERFECT FORM AT MMC DOES NOT APPLY WHEN RELATIONSHIP BETWEEN FEATURES IS ESTABLISHED BY ORIENTATION OR LOCATION TOLERANCES. SEPARATE POSITION CALLOUTS MAY BE GAGED SEPARATELY, REGARDLESS OF DATUM REFERENCE. ALL DIMENSIONS ARE IN MILLIMETERS	
THIRD ANGLE PROJECTION	DO NOT SCALE
USE MATH DATA	UNIGRAPHICS

DELPHI
DELPHI PACKARD ELECTRIC SYSTEMS
WARREN, OH

DR	DATE
APVD1 ADAM D. KIMBERLIN	28AU03
APVD2 ADAM D. KIMBERLIN	28AU03
APVD3 RON A. PUHL	28AU03
APVD4	
APVD5	

SUBSTANCES OF CONCERN AND RECYCLED CONTENT PER DELPHI 10949001

MATERIAL
M3592025 PA66 GRA MD

DRAWING NAME
CONN 3 F MIC/P 064

DRAWING NUMBER
15476608

SIZE	SCALE	FRAME NO	SHEET NO	STG	REV	N/P
A1	5:1	1 OF 1	1 OF 1	R	02	-