



The Cardinal Cappuccino Crystal Oscillator Dual LVDS/ LVPECL VCXO

Features

- 2.5V or 3.3V supply voltage- configurable
- 750 MHz to 1.5 GHz LVDS and LVPECL outputs- configurable
- Better than 2Hz tuning resolution
- Low power, typically 23mA LVDS and 54mA LVPECL
- Temperature range: -40°C to +85°C
- Stability: ± 25ppm
- APR: ±50ppm
- Phase Jitter (12kHz to 20MHz) .9ps RMS
- Switches between 2 Frequencies

Applications

- Multimedia
- Computing
- Networking, etc.

Part Numbering Example: CJVDY E 7 L Z - A7 BR - XXX.XXX / YYY.YYY

CJVDY	E	7	L	Z	A7	BR	XXX.XXX	YYY.YYY
SERIES	OUTPUT	PACKAGE STYLE	VOLTAGE	ADDED FEATURES	OPERATING TEMP.	STABILITY	FREQ. 0	FREQ. 1
CJVDY	L = LVDS	2 = 2.5 X 2	S = 2.5V	Z = Tape and Reel	A7 = -40°C to +85°C	BR = ± 25ppm	750-1500MHz	750-1500MHz
	E = LVPECL	5 = 5 X 3.2	L = 3.3V			BP = ± 50ppm	PIN 2	PIN 2
		7 = 5 X 7					Logic "0"	Logic "1"

Specification

Waveform	LVDS/LVPECL
Frequency	750MHz to 1500MHz
Operating Temperature Range	-40°C to +85°C
Storage Temperature Range	-55°C to +125°C
Supply Voltage	2.5V, 3.3V
Frequency Stability vs. Temp. Range	±25ppm/ ±50ppm
Input Current	23/54mA
Phase Jitter	.9ps Typical
Start-Up Time	10ms Max
Enable/ Disable Input Voltage	VIH ≥ 0.7VDD or No Connection, VIL ≤ 0.3VDD or Ground
Aging/ Year	±3ppm Max

Description

The Cardinal Cappuccino crystal oscillator is based on a high performance integrated circuit designed for use in Cardinal’s continued expanding leadership products in the programmable frequency control industry. Cardinal’s new Cappuccino design is today state of the art in oscillators. The Cappuccino line product features 10MHz to 1.5GHz with CJVDYE/ CJVDYL ranging 750MHz to 1.5GHz Output, 2.5V or 3.3V Supply Voltage, LVDS/ LVPECL commercial -20°C to +70°C and industrial temperature range -40°C to +85°C.

Cardinal’s new CJVDYE/ CJVDYL series is competitively priced and has the lowest typical power consumption 23/54mA LVDS/LVPECL (70% less power than the Fox XpressO™ oscillator), lowest jitter and best phase noise over 12 kHz to 20 MHz vs. the traditional fixed frequency quartz oscillators and Surface Acoustic Wave oscillators. Cardinal’s programming centers utilize modern robotics, for testing, programming and 100% final testing as we do with all our programmable offerings.

Cardinal’s Cappuccino line fits in all applications requiring a reference frequency including Multimedia, Computing, Networking, consumer etc.

Absolute Maximum Ratings

Item	Symbol	Condition	Unit
Input Voltage	V _I	-0.5 to V _{DD} + 0.5	V
Output Voltage	V _O	-0.5 to V _{DD} + 0.5	V
Positive Supply Voltage	V _{DD}	4.2	V
Storage Temperature		-55 to +125	°C



DC Electric Characteristics (T = 25°C)

Unless stated otherwise, the data presented here was taken over the following parameters, $V_{DD} = 3.3V \pm 10\%$ or $2.5V \pm 5\%$, $T_a = -40^\circ C$ to $+85^\circ C$ (industrial)

Item		Symbol	Specification			
			Min	Typ	Max	Units
Power Supply (V_{DD} , GND pins)	Power Supply Voltage	V_{DD}	2.97	3.3	3.63	V
		V_{DD}	2.375	2.5	2.625	V
	LVDS I_{DD}	I_{DD}		23		mA
	LVPECL I_{DD}	I_{DD}		54		mA
	Rise Time	T_{VDD}	100			μS
Vc pin	Input High Voltage ($V_{DD} = 3.3V$)	V_{IH}			$V_{DD} + .1 * V_{DD}$	V
	Absolute max Voltage ($V_{DD} = 3.3V$)				4	V
	Input High Voltage ($V_{DD} = 2.5V$)				$V_{DD} + .05 * V_{DD}$	V
	Input Low Voltage	V_{IL}	-0.3			V
	Input High Current	I_{IH}			5	μA
	Input Low Current	I_{IL}	-5			μA
	Input Impedance			1		$M\Omega$
	Vc Bandwidth		10			kHz
	Vc Pull		-100		100	ppm
Frequency Select Function FS Pin Input	Input High Voltage	V_{IH}	$0.7 * V_{DD}$			V
	Input Low Voltage	V_{IL}			$0.3 * V_{DD}$	V
	Input High Current	I_{IH}			5	μA
	Input Low Current	I_{IL}	-10			μA
	Equivalent Internal Pullup Resistance	R_{PULLUP}		900		$k\Omega$

Item	Symbol	Specification				
		Min	Typ	Max	Units	
AC Characteristics						
Outputs						
LVDS (OUT, nOUT)	Frequency Range	F_{LVDS}	750		1500	MHz
	Stability		-25		+25	ppm
	Operating Temperature		-40		+85	°C
	Differential Output Voltage	V_{OD}	175	350		mV
	V_{OD} Magnitude Change	ΔV_{OD}			50	mV
	Offset Voltage	V_{OS}		1.25		V
	V_{OS} Magnitude	ΔV_{OS}			50	mV
	Duty Cycle	$DODC_{LVDS}$	45		55	%
	Rise Time	t_R	125		350	ps
	Fall Time	t_F	150		350	ps
LVPECL (OUT, nOUT)	Frequency Range	F_{LVPECL}	750		1500	MHz
	Stability		-25		+25	ppm
	Operating Temperature		-40		+85	°C
	Output High Voltage	V_{OH}	$V_{DD} - 1.03$		$V_{DD} - .6$	V
	Output Low Voltage	V_{OL}	$V_{DD} - 1.85$		$V_{DD} - 1.6$	V
	Differential Duty Cycle	$DODC_{LVPECL}$	45		55	%
	Rise Time	t_R	150		250	ps
	Fall Time	t_F	150		250	ps
Jitter	Phase Jitter (12kHz to 20MHz)	t_{jit}	0.4	0.9	1.5	ps rms
	Period Jitter	$t_{RMS, DIFF}$		3	4.5	ps
		$t_{p-p, DIFF}$			30	45

Performance Characteristic Curves

Unless otherwise specified, data is characterized over temperature range -40°C to +85°C and voltage range 2.2V - 3.63V.

I_{DD} vs. V_{DD}

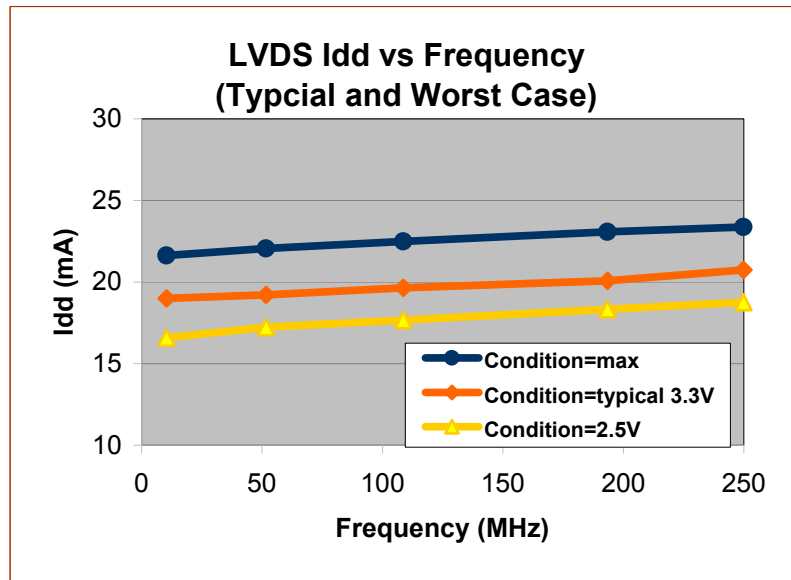

Figure 1. LVDS I_{DD} vs. Frequency, V_{DD}

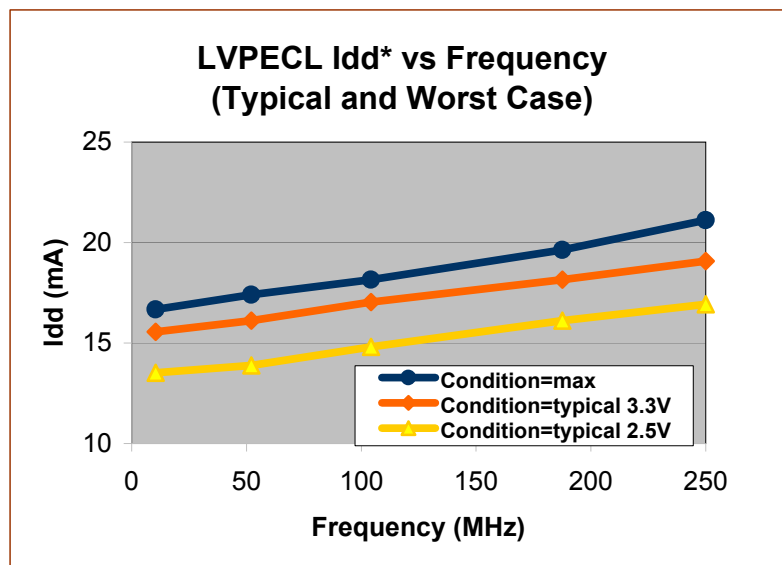

Figure 2. LVPECL I_{DD} vs. Frequency, V_{DD}

***Note: LVPECL I_{DD} does not include output load current
Add 32 mA to include output load current**

Waveform Measurements

The following figures are descriptions for how the waveforms are measured for the datasheet applications.

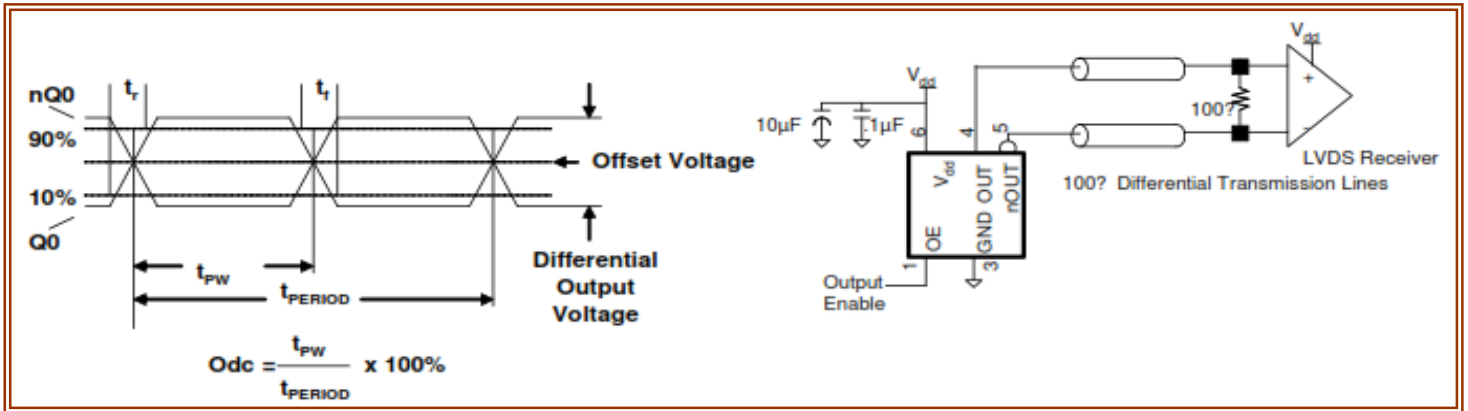
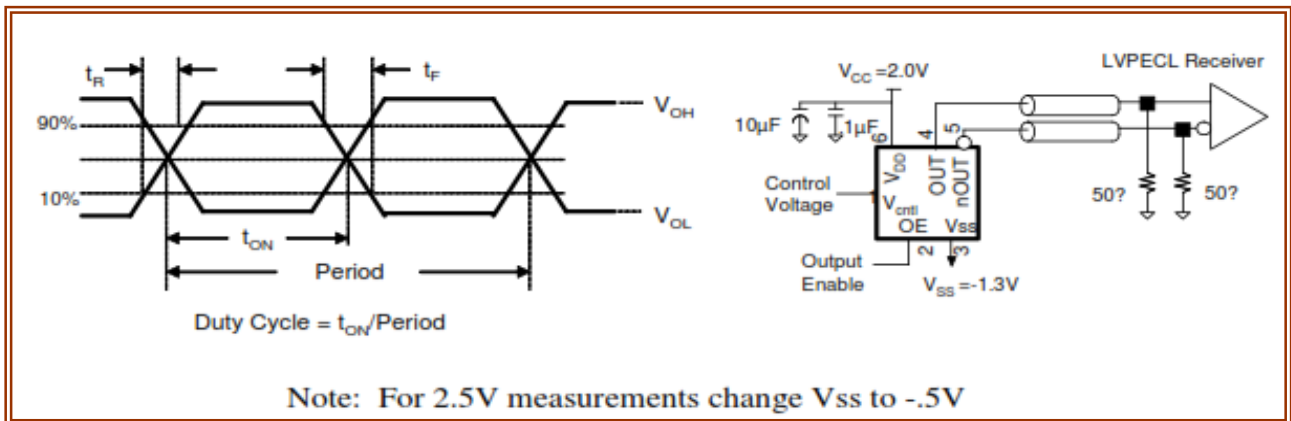

Figure 11. 3.3V or 2.5V LVDS waveform measurement test setup



Note: For 2.5V measurements change Vss to -.5V

Figure 12. 3.3V LVPECL waveform measurement test setup

Application Information

Termination for 3.3V LVPECL Output

The clock layout topology shown below is a typical termination for LVPECL outputs. The two different layouts offered are recommended only as guidelines.

OUT and nOUT are low impedance following outputs that generate LVPECL compatible outputs. Therefore, terminating resistors (DC current path to ground) or current sources must be used for functionality. These outputs are designed to drive 50Ω transmission lines. Matched impedance techniques should be used to maximize operating frequency and minimize signal distortion. Figures 13 and 14 present two different designs. They are recommended only as guidelines. Other suitable clock layouts may exist and it would be recommended that the board designer simulate to guarantee compatibility across all printed circuit and clock component process variations.

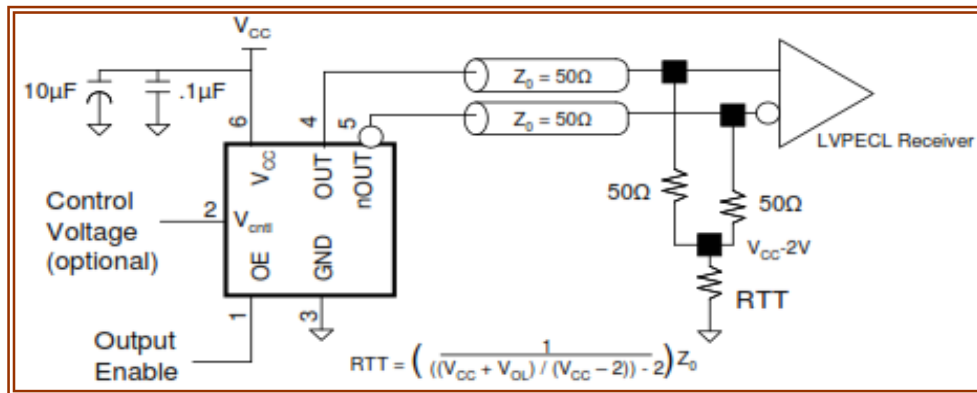

Figure 13. 3.3V LVPECL XO Application Schematic & Power Supply Decoupling

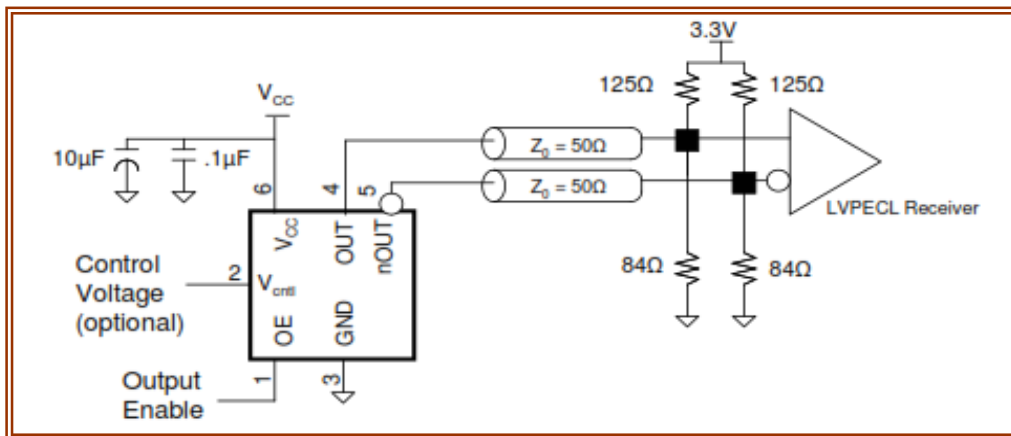

Figure 14. Alternante 3.3V LVPECL XO Application Schematic & Power Supply Decoupling

Termination for 2.5V LVPECL Output

Figure 15-17 shows examples of termination for 2.5V LVPECL drivers. These terminations are equivalent to terminating 50Ω to VCC-2V. For VCC = 2.5V, the VCC-2V is very close to ground level. The 18Ω in Figure 16 can be eliminated and termination is shown in Figure 17.

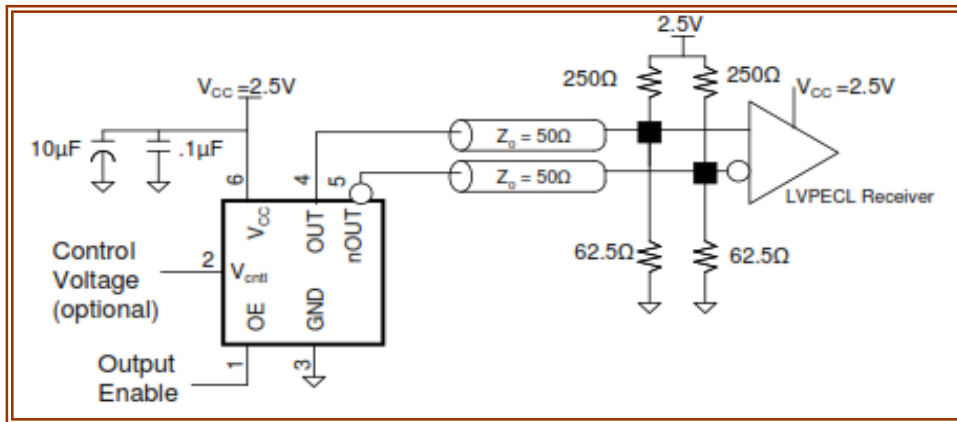

Figure 15. 2.5V LVPECL XO Drive Termination Example

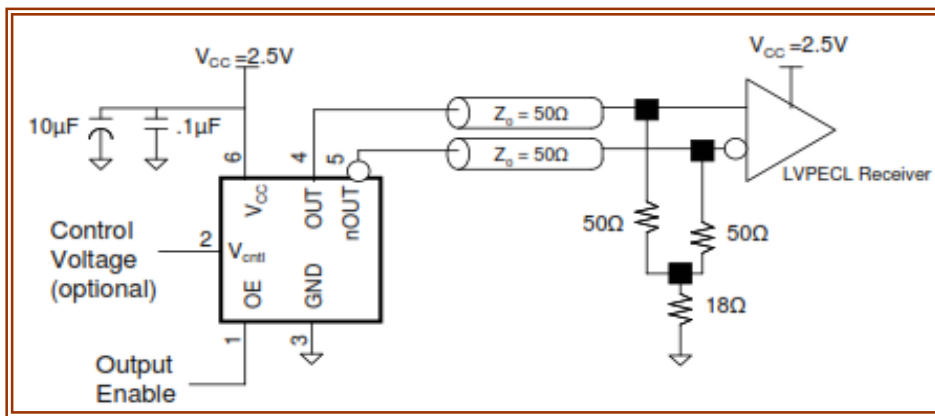

Figure 16. Alternate 2.5V LVPECL XO Drive Termination Example

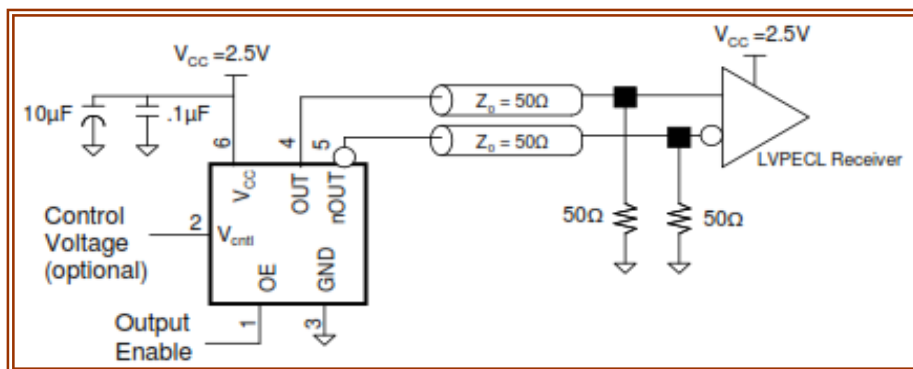

Figure 17. Alternate 2.5V LVPECL XO Drive Termination Example

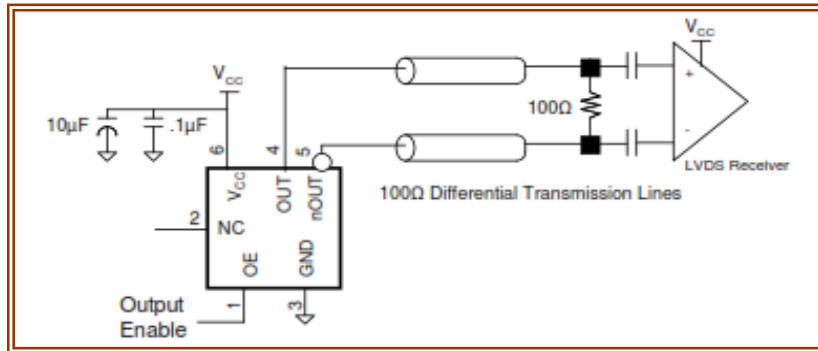

Figure 18. Termination for 3.3V and 2.5V LVDS Output

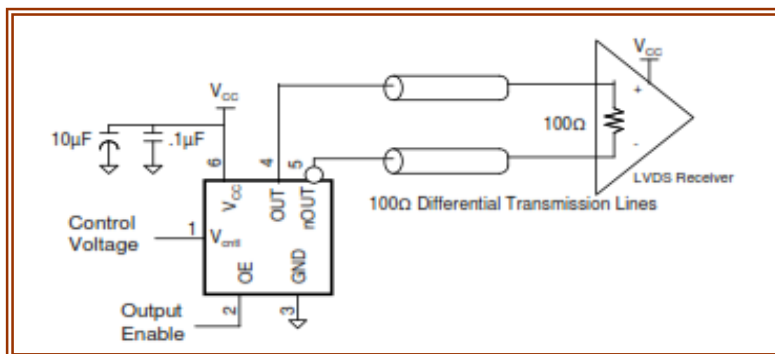
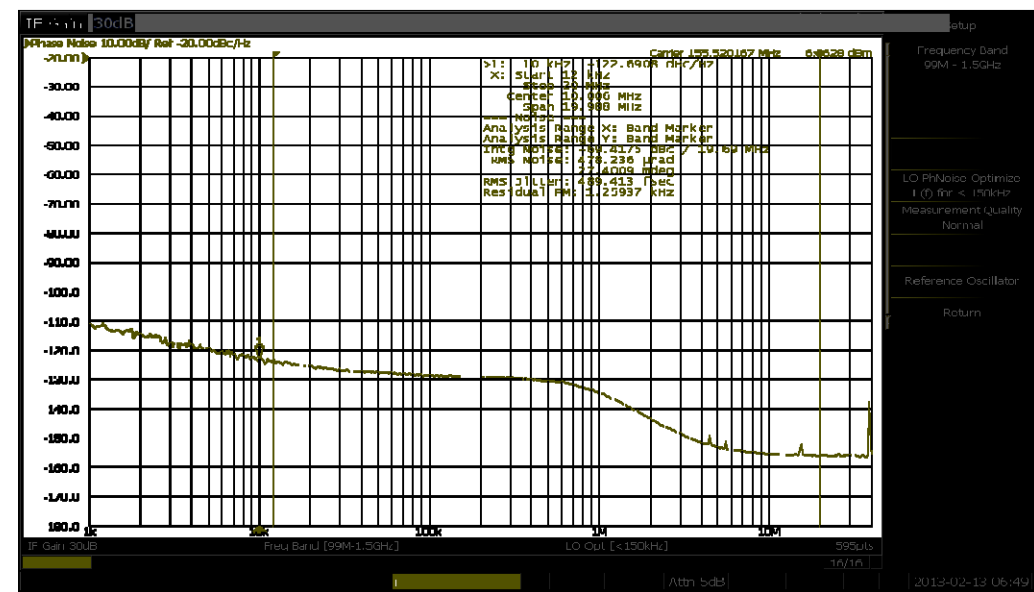
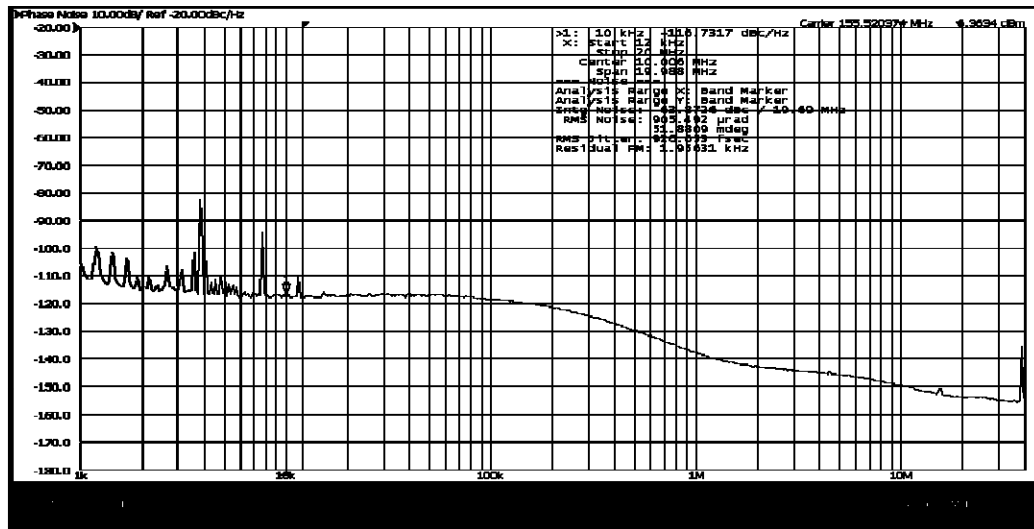
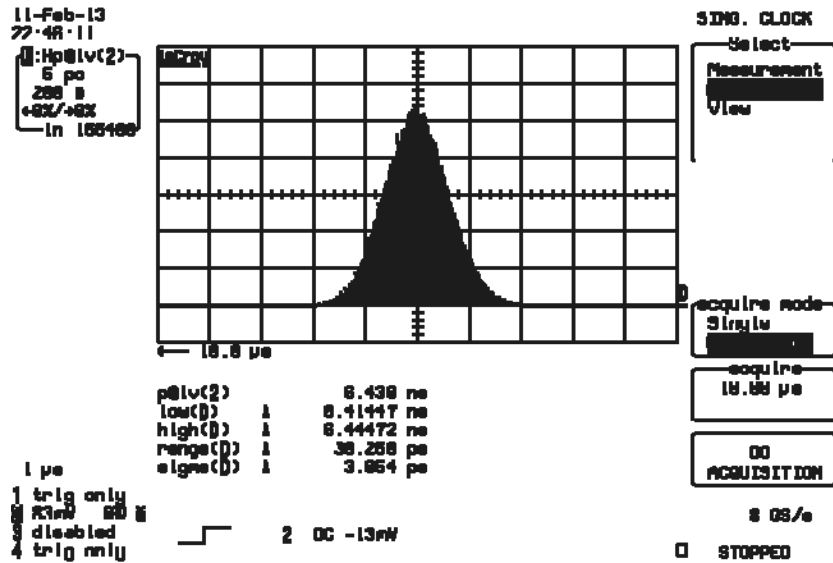

Figure 19. 3.3V and 2.5V LVDS XO Application Schematic & Power Supply Decoupling

Phase Noise & Jitter Plots



145 Route 46 West
Wayne, NJ 07470

Recommended Solder Profile for
 Cardinal Components, Inc.
 Package Infrared Reflow.
 Do Not Use Ultrasonic-Wave Soldering or
 Wave Solder with Package Immersed in Solder
 Damage to Crystal will result.

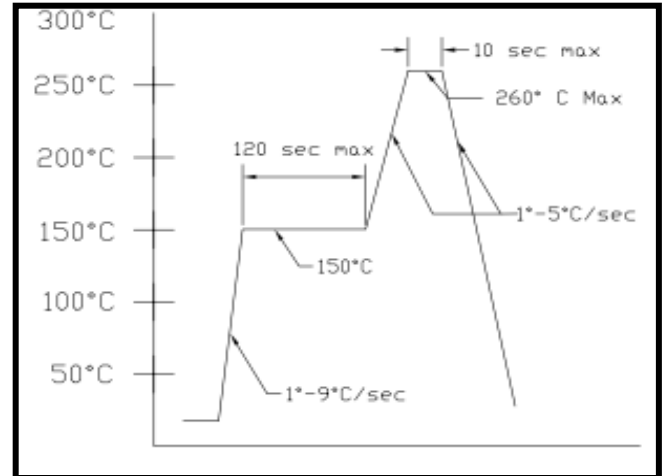

Reliability

Cardinal Components Inc., qualification includes aging at various extreme temperatures, shocks and vibration, temperature cycling, and IR reflow simulation. The Cappuccino family meets the following qualification tests:

Environmental Compliance	
Parameter	Conditions
Mechanical Shock	MIL-STD-883, Method 2002
Mechanical Vibration	MIL-STD-883, Method 2007
Solderability	MIL-STD-883, Method 2003
Gross and Fine Leak	MIL-STD-883, Method 1014
Resistance to Solvents	MIL-STD-883, Method 2016
Moisture Sensitivity Level	IPC/ JEDEC J-STD-020, MSL1

Handling Precautions

Although ESD protection circuitry has been designed into the Cappuccino proper precautions should be taken when handling and mounting. Cardinal employs a human body model (HBM) and a charged-device model (CDM) for ESD susceptibility testing and design protection evaluation.

ESD Ratings		
Model	Minimum	Conditions
Human Body Model	1000V	MIL-STD-883, Method 3015
Charged Device Model	900V	JEDEC, JESD22-C101
Machine Model	200V	JEDEC, JESD22-A115-A



145 Route 46 West
 Wayne, NJ 07470

Style 7: 5x7mm

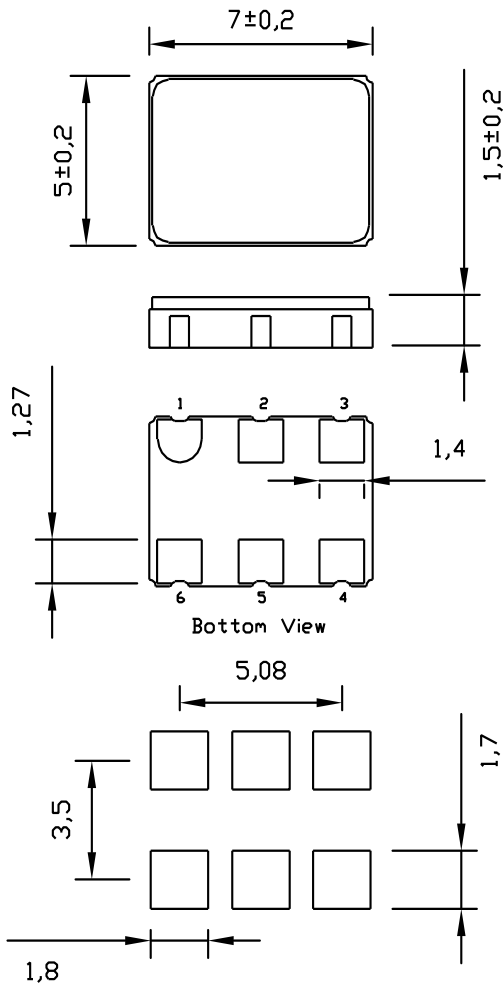

Style 5: 5x3.2mm

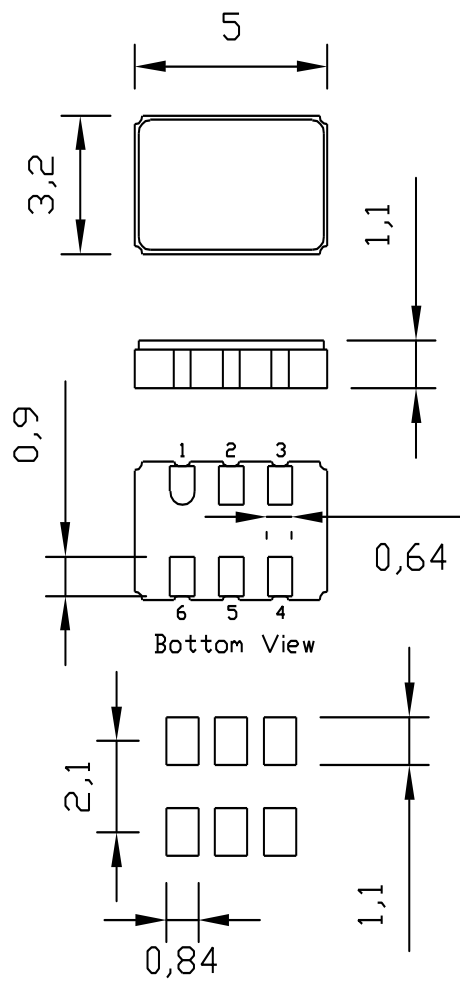

Style 2: 2.5 X 2 mm

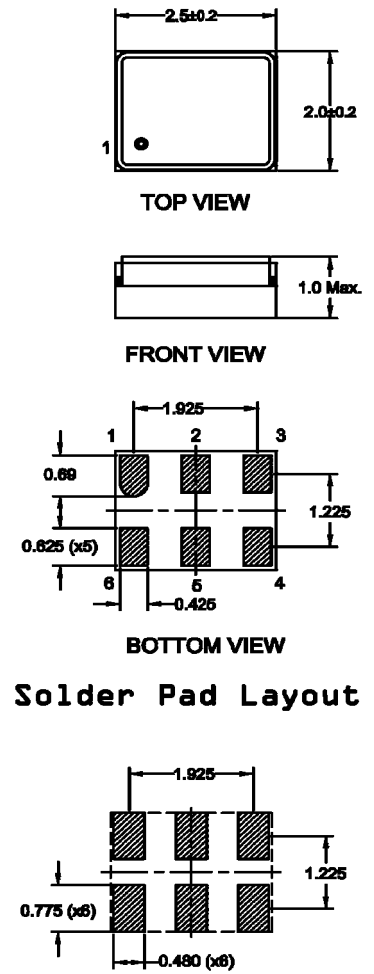

6 Pad LVDS/LVPECL	
Pin 1	VC
Pin 2	FS Frequency Select
Pin 3	GND
Pin 4	Out
Pin 5	nOUT
Pin 6	V _{DD}

6 Pad LVDS/LVPECL	
Pin 1	VC
Pin 2	FS Frequency Select
Pin 3	GND
Pin 4	Out
Pin 5	nOUT
Pin 6	V _{DD}

6 Pad LVDS/LVPECL	
Pin 1	VC
Pin 2	FS Frequency Select
Pin 3	GND
Pin 4	Out
Pin 5	nOUT
Pin 6	V _{DD}

Tape and Reel Specifications

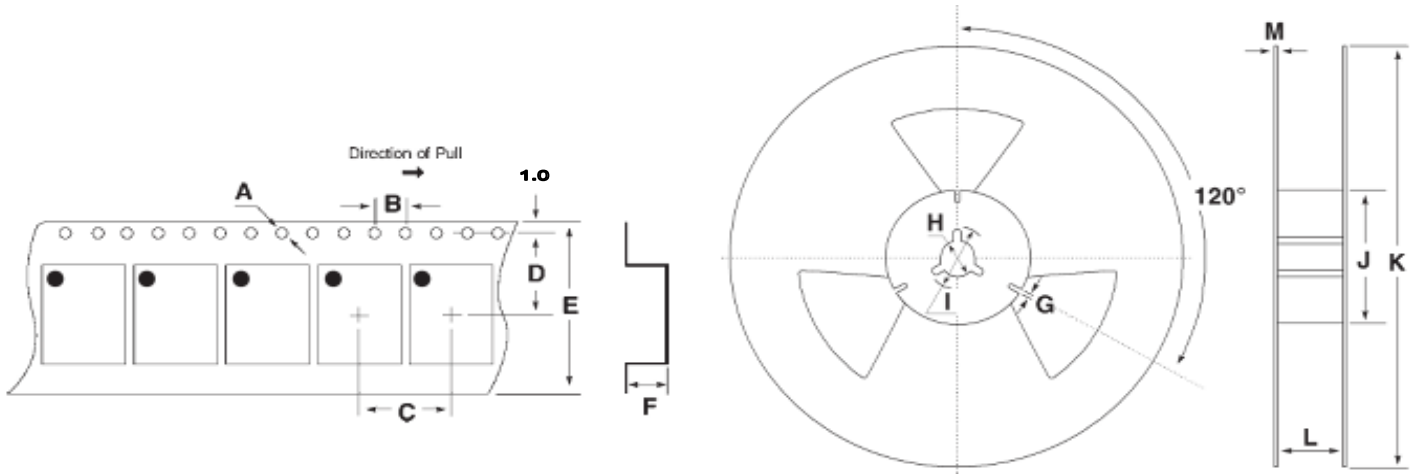

Tape Specifications (mm)

Package	A	B	C	D	E	F	QTY
2 = 2.5 X 2	1.5	4.0	4.0	3.5	8.0	1.1	1,000
5 = 5 X 3.2	1.5	4.0	8.0	5.5	12.0	1.8	1,000
7 = 7 X 5	1.5	4.0	8.0	7.5	16.0	2.2	1,000

Reel Specifications (mm)

Package	G	H	I	J	K	L	M
2 = 2.5 X 2	2.0	13	21	60	180	9.0	1.8
5 = 5 X 3.2	2.0	13	21	60	180	13.0	1.25
7 = 7 X 5	2.0	13	21	60	180	17.0	1.25