

✓ 54/74283 010004
 ✓ 54LS/74LS283 010006

4-BIT BINARY FULL ADDER
 (With Fast Carry)

DESCRIPTION — The '283 high speed 4-bit binary full adders with internal carry lookahead accept two 4-bit binary words ($A_0 - A_3, B_0 - B_3$) and a Carry input (C_0). They generate the binary Sum outputs ($S_0 - S_3$) and the Carry output (C_4) from the most significant bit. They operate with either active HIGH or active LOW operands (positive or negative logic).

ORDERING CODE: See Section 9

PKGS	PIN OUT	COMMERCIAL GRADE	MILITARY GRADE	PKG TYPE
		$V_{CC} = +5.0 V \pm 5\%$, $T_A = 0^\circ C \text{ to } +70^\circ C$	$V_{CC} = +5.0 V \pm 10\%$, $T_A = -55^\circ C \text{ to } +125^\circ C$	
Plastic DIP (P)	A	74283PC, 74LS283PC		9B
Ceramic DIP (D)	A	74283DC, 74LS283DC	54283DM, 54LS283DM	6B
Flatpak (F)	A	74283FC, 74LS283FC	54283FM, 54LS283FM	4L

CONNECTION DIAGRAM
 PINOUT A

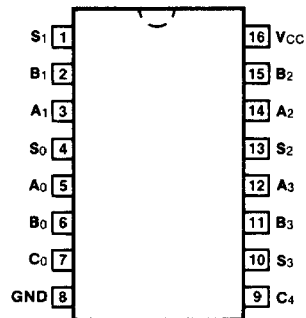

INPUT LOADING/FAN-OUT: See Section 3 for U.L. definitions

PIN NAMES	DESCRIPTION	54/74 (U.L.) HIGH/LOW	54/74LS (U.L.) HIGH/LOW
$A_0 - A_3$	A Operand Inputs	1.0/1.0	1.0/0.5
$B_0 - B_3$	B Operand Inputs	1.0/1.0	1.0/0.5
C_0	Carry Input	1.0/1.0	0.5/0.25
$S_0 - S_3$	Sum Outputs	20/10	10/5.0 (2.5)
C_4	Carry Output	10/5.0	10/5.0 (2.5)

LOGIC SYMBOL

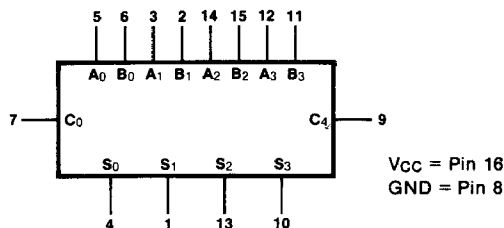

FUNCTIONAL DESCRIPTION — The '283 adds two 4-bit binary words (A plus B) plus the incoming carry C_0 . The binary sum appears on the Sum ($S_0 - S_3$) and outgoing carry (C_4) outputs. The binary weight of the various inputs and outputs is indicated by the subscript numbers, representing powers of two.

$$2^0 (A_0 + B_0 + C_0) + 2^1 (A_1 + B_1) + 2^2 (A_2 + B_2) + 2^3 (A_3 + B_3) = S_0 + 2S_1 + 4S_2 + 8S_3 + 16C_4$$

Where (+) = plus

Interchanging inputs of equal weight does not affect the operation. Thus C_0 , A_0 , B_0 can be arbitrarily assigned to pins 5, 6 and 7. Due to the symmetry of the binary add function, the '283 can be used either with all inputs and outputs active HIGH (positive logic) or with all inputs and outputs active LOW (negative logic). Note that if C_0 is not used it must be tied LOW for active HIGH logic or tied HIGH for active LOW logic.

Example:

	C_0	A_0	A_1	A_2	A_3	B_0	B_1	B_2	B_3	S_0	S_1	S_2	S_3	C_4
Logic Levels	L	L	H	L	H	H	L	L	H	H	H	L	L	H
Active HIGH	0	0	1	0	1	1	0	0	1	1	1	0	0	1
Active LOW	1	1	0	1	0	0	1	1	0	0	0	1	1	0

Active HIGH: $0 + 10 + 9 = 3 + 16$

Active LOW: $1 + 5 + 6 = 12 + 0$

Due to pin limitations, the intermediate carries of the '283 are not brought out for use as inputs or outputs. However, other means can be used to effectively insert a carry into, or bring a carry out from, an intermediate stage. *Figure a* shows a way of making a 3-bit adder. Tying the operand inputs of the fourth adder (A_3 , B_3) LOW makes S_3 dependent only on, and equal to, the carry from the third adder. Using somewhat the same principle, *Figure b* shows a way of dividing the '283 into a 2-bit and a 1-bit adder. The third stage adder (A_2 , B_2 , S_2) is used merely as a means of getting a carry (C_{10}) signal into the fourth stage (via A_2 and B_2) and bringing out the carry from the second stage on S_2 . Note that as long as A_2 and B_2 are the same, whether HIGH or LOW, they do not influence S_2 . Similarly, when A_2 and B_2 are the same the carry into the third stage does not influence the carry out of the third stage. *Figure c* shows a method of implementing a 5-input encoder, where the inputs are equally weighted. The outputs S_0 , S_1 and S_2 present a binary number equal to the number of inputs $I_1 - I_5$ that are true. *Figure d* shows one method of implementing a 5-input majority gate. When three or more of the inputs $I_1 - I_5$ are true, the output M_5 is true.

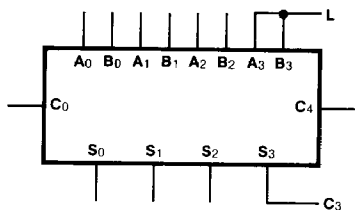

Fig. a 3-Bit Adder

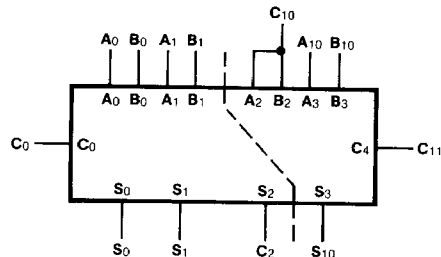

Fig. b 2-Bit and 1-Bit Adders

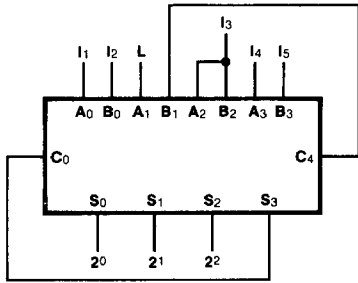

Fig. c 5-Input Encoder

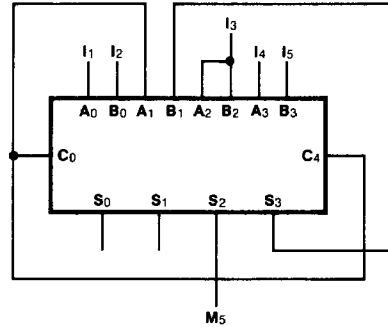
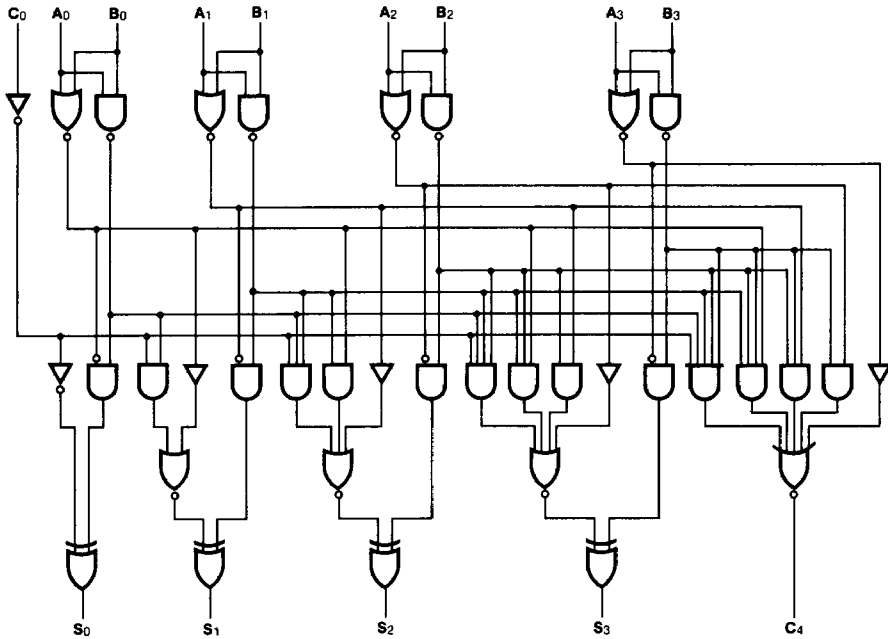

Fig. d 5-Input Majority Gate

LOGIC DIAGRAM



DC CHARACTERISTICS OVER OPERATING TEMPERATURE RANGE (unless otherwise specified)

SYMBOL	PARAMETER	54/74		54/74LS		UNITS	CONDITIONS	
		Min	Max	Min	Max			
I _{OS}	Output Short Circuit Current at S _n	XM	-20	-55	-20	-100	mA	V _{CC} = Max
		XC	-18	-55	-20	-100		
I _{OS}	Output Short Circuit Current at C ₄	XM	-20	-70	-20	-100	mA	V _{CC} = Max
		XC	-18	-70	-20	-100		
I _{CC}	Power Supply Current	XM	99		39		mA	V _{CC} = Max, Inputs = Gnd ('LS283) Inputs = 4.5 V ('283)
		XC	110		39			
		XM, XC			34		mA	V _{CC} = Max Inputs = 4.5 V ('LS283)

AC CHARACTERISTICS: V_{CC} = 5.0 V, T_A = 25°C (See Section 3 for waveforms and load configurations)

SYMBOL	PARAMETER	54/74		54/74LS		UNITS	CONDITIONS
		C _L = 15 pF R _L = 400 Ω		C _L = 15 pF			
		Min	Max	Min	Max		
t _{PLH} t _{PHL}	Propagation Delay C ₀ to S _n	21		24		ns	Figs. 3-1, 3-20
		21		24			
t _{PLH} t _{PHL}	Propagation Delay A _n or B _n to S _n	24		24		ns	Figs. 3-1, 3-20
		24		24			
t _{PLH} t _{PHL}	Propagation Delay C ₀ to C ₄	14		17		ns	Figs. 3-1, 3-5 R _L = 780 Ω ('283)
		16		17			
t _{PLH} t _{PHL}	Propagation Delay A _n or B _n to C ₄	14		17		ns	Figs. 3-1, 3-5 R _L = 780Ω ('283)
		16		17			