

NB4N121K

3.3V Differential In 1:21 Differential Fanout Clock Driver with HCSL level Output

Description

The NB4N121K is a Clock differential input fanout distribution 1 to 21 HCSL level differential outputs, optimized for ultra low propagation delay variation. The NB4N121K is designed with HCSL clock distribution for FBDIMM applications in mind.

Inputs can accept differential LVPECL, CML, or LVDS levels. Single-ended LVPECL, CML, LVCMOS or LVTTL levels are accepted with the proper V_{REFAC} supply (see Figures 5, 10, 11, 12, and 13). Clock input pins incorporate an internal $50\ \Omega$ on die termination resistors.

Output drive current at I_{REF} (Pin 1) for 1X load is selected by connecting to GND. To drive a 2X load, connect I_{REF} to V_{CC} . See Figure 9.

The NB4N121K specifically guarantees low output-to-output skews. Optimal design, layout, and processing minimize skew within a device and from device to device. System designers can take advantage of the NB4N121K's performance to distribute low skew clocks across the backplane or the motherboard.

Features

- Typical Input Clock Frequency 100, 133, 166, 200, 266, 333 and 400 MHz
- 340 ps Typical Rise and Fall Times
- 800 ps Typical Propagation Delay
- Δt_{pd} 100 ps Maximum Propagation Delay Variation Per Each Differential Pair
- <1 ps RMS Additive Clock jitter
- Operating Range: $V_{CC} = 3.0\text{ V}$ to 3.6 V with $V_{EE} = 0\text{ V}$
- Differential HCSL Output Level (700 mV Peak-to-Peak)
- Pb-Free Packages are Available



ON Semiconductor®

<http://onsemi.com>

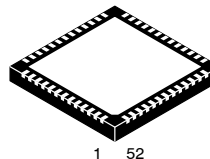

QFN-52
MN SUFFIX
CASE 485M

MARKING DIAGRAM*

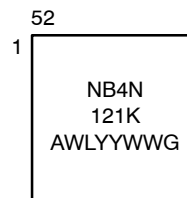

- A = Assembly Site
- WL = Wafer Lot
- YY = Year
- WW = Work Week
- G = Pb-Free Package

*For additional marking information, refer to Application Note AND8002/D.

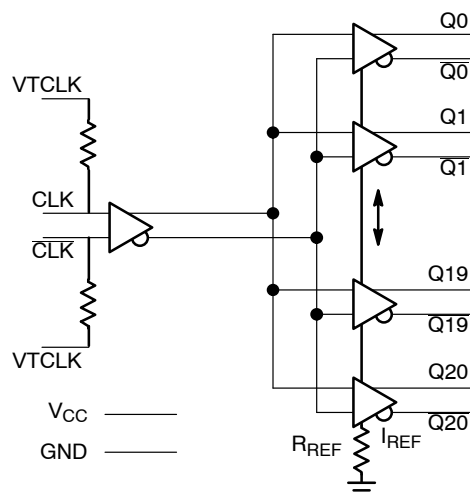

Figure 1. Pin Configuration (Top View)

ORDERING INFORMATION

See detailed ordering and shipping information in the package dimensions section on page 8 of this data sheet.

NB4N121K

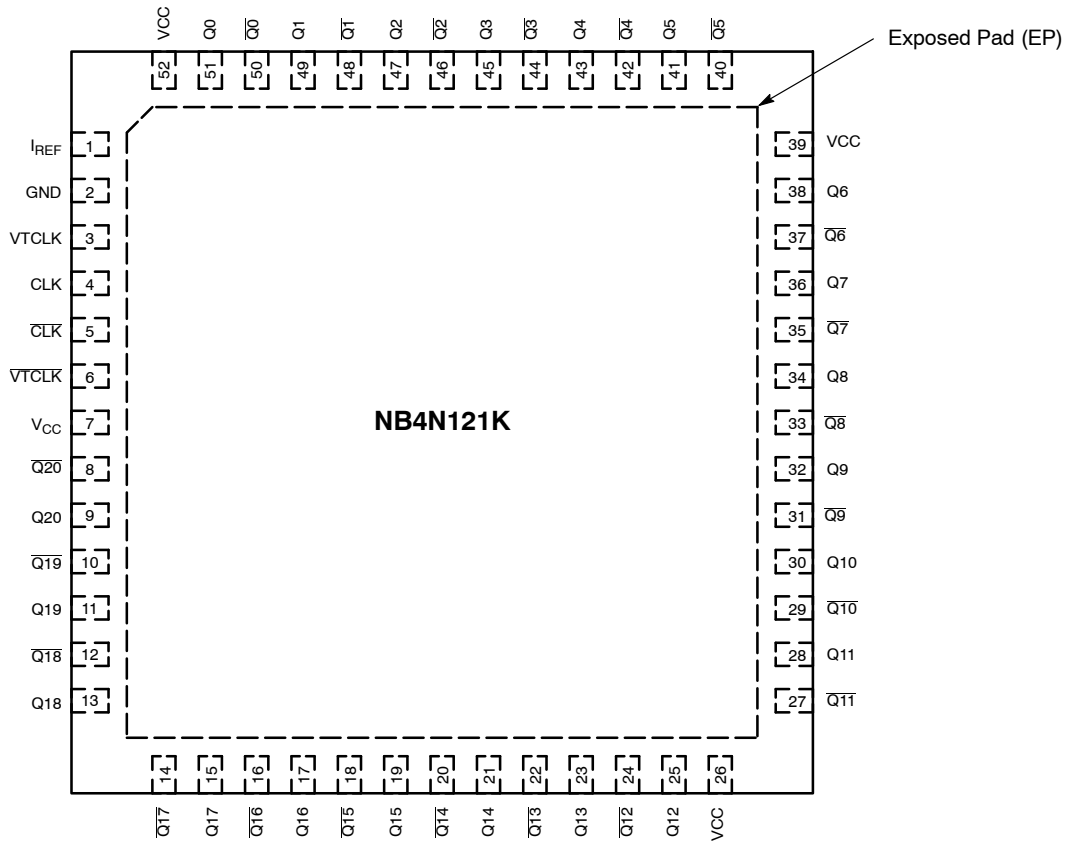

Figure 2. Pinout Configuration (Top View)

Table 1. PIN DESCRIPTION

Pin	Name	I/O	Description
1	I _{REF}	Output	Output current programming pin to select load drive. For 1X configuration, connect I _{REF} to GND, or for 2X configuration, connect I _{REF} to V _{CC} (See Figure 9).
2	GND	-	Supply Ground. GND pin must be externally connected to power supply to guarantee proper operation.
3, 6	VTCLK, VTCLK	-	Internal 50 Ω Termination Resistor connection Pins. In the differential configuration when the input termination pins are connected to the common termination voltage, and if no signal is applied then the device may be susceptible to self-oscillation.
4	CLK	LVPECL Input	CLOCK Input (TRUE)
5	CLK	LVPECL Input	CLOCK Input (INVERT)
7, 26, 39, 52	V _{CC}	-	Positive Supply pins. V _{CC} pins must be externally connected to a power supply to guarantee proper operation.
8, 10, 12, 14, 16, 18, 20, 22, 24, 27, 29, 31, 33, 35, 37, 40, 42, 44, 46, 48, 50	Q[20-0]	HCSL Output	Output (INVERT)
9, 11, 13, 15, 17, 19, 21, 23, 25, 28, 30, 32, 34, 36, 38, 41, 43, 45, 47, 49, 51	Q[20-0]	HCSL Output	Output (TRUE)
Exposed Pad	EP	GND	Exposed Pad. The thermally exposed pad (EP) on package bottom (see case drawing) must be attached to a sufficient heat-sinking conduit for proper thermal operation. (Note 1)

1. The exposed pad must be connected to the circuit board ground.

NB4N121K

Table 2. ATTRIBUTES

Characteristic	Value
Input Default State Resistors	None
ESD Protection	Human Body Model Machine Model
Moisture Sensitivity (Note 2)	QFN-52
Flammability Rating Oxygen Index: 28 to 34	UL 94 V-0 @ 0.125 in
Transistor Count	622
Meets or exceeds JEDEC Spec EIA/JESD78 IC Latchup Test	

2. For additional information, see Application Note AND8003/D.

Table 3. MAXIMUM RATINGS (Note 3)

Symbol	Parameter	Condition 1	Condition 2	Rating	Unit
V_{CC}	Positive Power Supply	GND = 0 V		4.6	V
V_I	Positive Input	GND = 0 V		$GND - 0.3 \leq V_I \leq V_{CC}$	V
V_{INPP}	Differential Input Voltage	CLK - CLKb		V_{CC}	V
I_{OUT}	Output Current	Continuous Surge		50 100	mA mA
T_A	Operating Temperature Range	QFN-52		-40 to +70	°C
T_{stg}	Storage Temperature Range			-65 to +150	°C
θ_{JA}	Thermal Resistance (Junction-to-Ambient) (Note 3)	0 lfpm 500 lfpm	QFN-52 QFN-52	25 19.6	°C/W °C/W
θ_{JC}	Thermal Resistance (Junction-to-Case)	2S2P (Note 4)	QFN-52	21	°C/W
T_{sol}	Wave Solder	Pb-Free		265	°C

Stresses exceeding Maximum Ratings may damage the device. Maximum Ratings are stress ratings only. Functional operation above the Recommended Operating Conditions is not implied. Extended exposure to stresses above the Recommended Operating Conditions may affect device reliability.

3. JEDEC standard 51-6, multilayer board - 2S2P (2 signal, 2 power).

4. JEDEC standard multilayer board - 2S2P (2 signal, 2 power) with 8 filled thermal vias under exposed pad.

NB4N121K

Table 4. DC CHARACTERISTICS ($V_{CC} = 3.0\text{ V to }3.6\text{ V}$, $T_A = -40^\circ\text{C to }+70^\circ\text{C}$ Note 5)

Symbol	Characteristic	Min	Typ	Max	Unit
I_{GND}	GND Supply Current (All Outputs Loaded)	70	98	120	mA
I_{CC}	Power Supply Current (All Outputs Loaded)		420 780		mA
					1X 2X
I_{IH}	Input HIGH Current CLK_x , \overline{CLK}_x		2.0	150	μA
I_{IL}	Input LOW Current CLK_x , \overline{CLK}_x	-150	-2.0		μA

DIFFERENTIAL INPUT DRIVEN SINGLE-ENDED (Figures 5 and 7)

V_{th}	Input Threshold Reference Voltage Range (Note 6)	1050		$V_{CC} - 150$	mV
V_{IH}	Single-Ended Input HIGH Voltage	$V_{th} + 150$		V_{CC}	mV
V_{IL}	Single-Ended Input LOW Voltage	GND		$V_{th} - 150$	mV

DIFFERENTIAL INPUTS DRIVEN DIFFERENTIALLY (Figures 6 and 8)

V_{IHD}	Differential Input HIGH Voltage	1200		V_{CC}	mV
V_{ILD}	Differential Input LOW Voltage	GND		$V_{CC} - 75$	mV
V_{ID}	Differential Input Voltage ($V_{IHD} - V_{ILD}$)	75		2400	mV
V_{CMR}	Input Common Mode Range	1163		$V_{CC} - 75$	

HCSL OUTPUTS (Figure 4)

V_{OH}	Output HIGH Voltage	600	740	900	mV
V_{OL}	Output LOW Voltage	-150	0	150	mV

NOTE: Device will meet the specifications after thermal equilibrium has been established when mounted in a test socket or printed circuit board with maintained transverse airflow greater than 500 lfm. Electrical parameters are guaranteed only over the declared operating temperature range. Functional operation of the device exceeding these conditions is not implied. Device specification limit values are applied individually under normal operating conditions and not valid simultaneously.

- Input parameters vary 1:1 with V_{CC} . Measurements taken with outputs in either 1X (all outputs loaded $50\ \Omega$ to GND) or 2X (all outputs loaded $25\ \Omega$ to GND) configuration, see Figure 9. For 1X configuration, connect I_{REF} to GND, or for 2X configuration, connect I_{REF} to V_{CC} .
- V_{th} is applied to the complementary input when operating in single ended mode.

NB4N121K

Table 5. AC CHARACTERISTICS $V_{CC} = 3.0\text{ V to }3.6\text{ V}$, $GND = 0\text{ V}$; $-40^{\circ}\text{C to }+70^{\circ}\text{C}$ (Note 7)

Symbol	Characteristic	Min	Typ	Max	Unit	
V_{OUTPP}	Output Voltage Amplitude (@ $V_{INPPmin}$) $f_{in} = 133\text{ MHz}$ $f_{in} = 166\text{ MHz}$ $f_{in} = 200\text{ MHz}$		725 725 725	900 900 900	mV	
t_{PLH} , t_{PHL}	Propagation Delay to (See Figure 3) CLK/ $\overline{\text{CLK}}$ to $Q_x/\overline{Q_x}$	550	800	950	ps	
Δt_{PLH} , Δt_{PHL}	Propagation Delay Variations Variation Per Each Diff Pair CLK/ $\overline{\text{CLK}}$ to $Q_x/\overline{Q_x}$ (Note 8) (See Figure 3)			100	ps	
t_{SKEW}	Duty Cycle Skew (Note 9) Within-Device Skew, 1X Mode Only (Note 10) Within-Device Skew, 2X Mode (Note 10) Device-to-Device Skew (Note 10)			20 50 80 150	ps ps ps ps	
t_{JITTER}	RMS Random Clock Jitter (Note 11) $f_{in} = 133\text{ MHz}$ $f_{in} = 166\text{ MHz}$ $f_{in} = 200\text{ MHz}$			1	ps	
V_{cross}	Absolute Crossing Magnitude Voltage	250		550	mV	
ΔV_{cross}	Variation in Magnitude of V_{cross}			150	mV	
t_r , t_f	Absolute Magnitude in Output Risetime and Falltime (From 175 mV to 525 mV)	Q_x , $\overline{Q_x}$	175	340	700	ps
Δt_r , Δt_f	Variation in Magnitude of Risetime and Falltime (Single-Ended) (See Figure 4)	Q_x , $\overline{Q_x}$ 1X 2X		125 150	ps	

NOTE: Device will meet the specifications after thermal equilibrium has been established when mounted in a test socket or printed circuit board with maintained transverse airflow greater than 500 lpm. Electrical parameters are guaranteed only over the declared operating temperature range. Functional operation of the device exceeding these conditions is not implied. Device specification limit values are applied individually under normal operating conditions and not valid simultaneously.

7. Measured by forcing V_{INPP} (MIN) from a 50% duty cycle clock source. Measurements taken with outputs in either 1X (all outputs loaded $50\ \Omega$ to GND) or 2X (all outputs loaded $25\ \Omega$ to GND) configuration, see Figure 9. For 1X configuration, connect I_{REF} to GND, or for 2X configuration, connect I_{REF} to V_{CC} . Typical gain is 20 dB.
8. Measured from the input pair crosspoint to each single output pair crosspoint across temp and voltage ranges.
9. Duty cycle skew is measured between differential outputs using the deviations of the sum of $Tpw-$ and $Tpw+$.
10. Skew is measured between outputs under identical transition @ 133 MHz.
11. Additive RMS jitter with 50% duty cycle clock signal using phase noise integrated from 12 KHz to 33 MHz

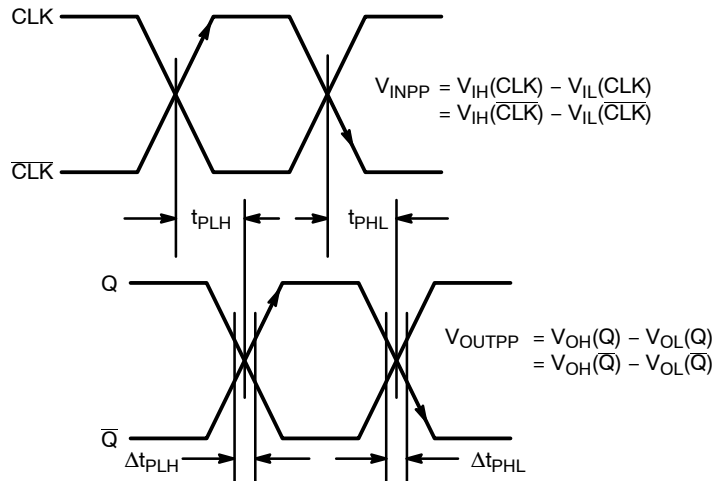

Figure 3. AC Reference Measurement

NB4N121K

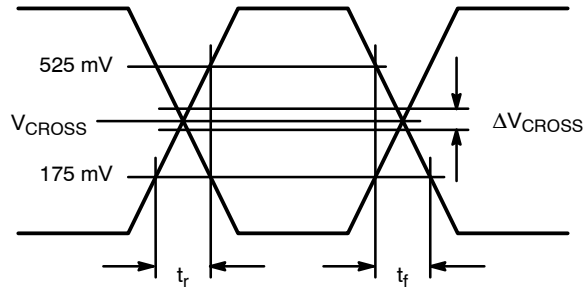

Figure 4. HCSL Output Parameter Characteristics

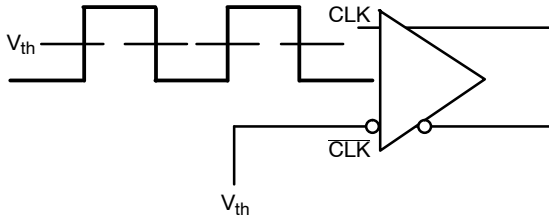

Figure 5. Differential Input Driven Single-Ended ($V_{th} = V_{REFAC}$)

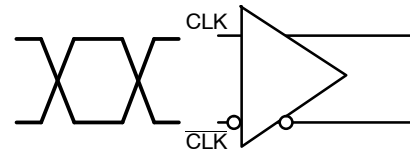

Figure 6. Differential Inputs Driven Differentially

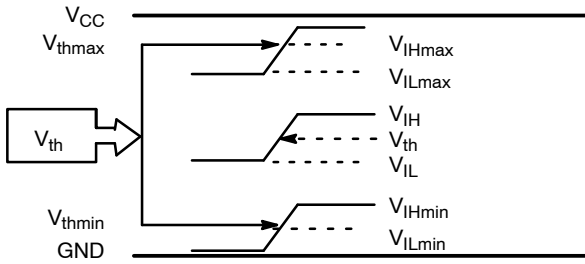

Figure 7. V_{th} Diagram

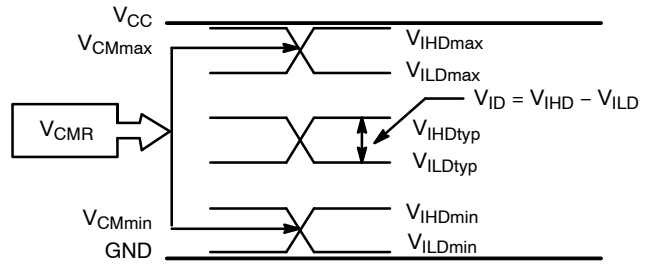

Figure 8. V_{CMR} Diagram

NB4N121K

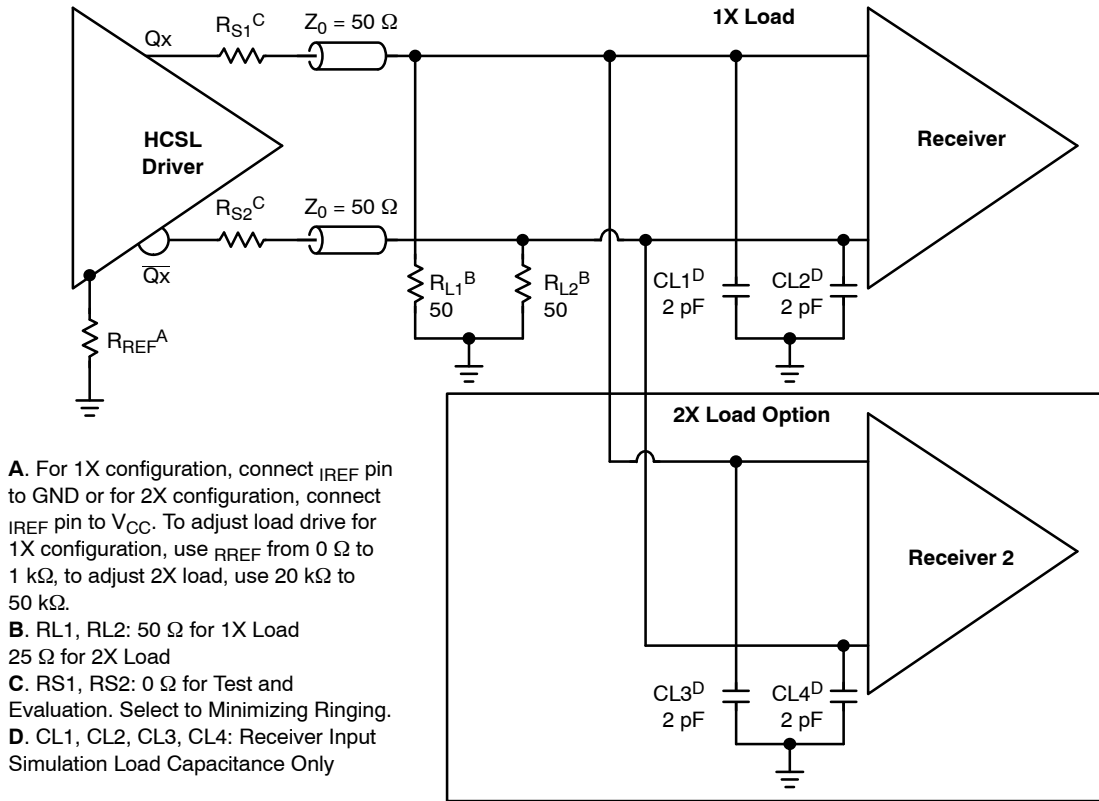
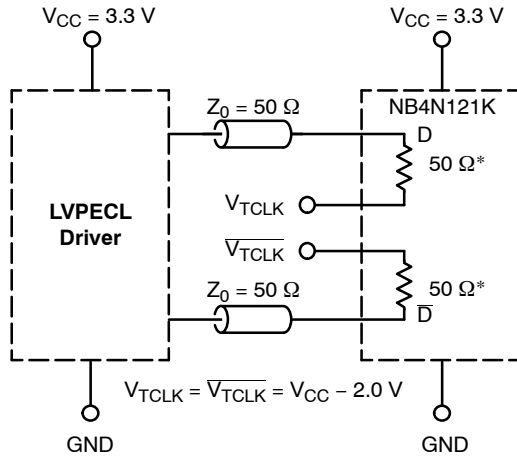
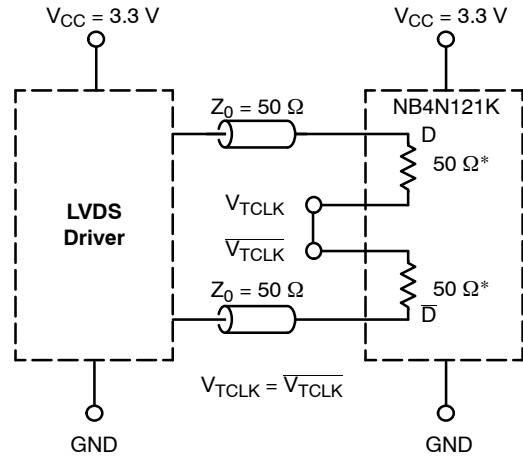

Figure 9. Typical Termination Configuration for Output Driver and Device Evaluation C_{Lx} for Test Only (Representing Receiver Input Loading); Not Added to Application



*RTIN, Internal Input Termination Resistor

Figure 10. LVPECL Interface



*RTIN, Internal Input Termination Resistor

Figure 11. LVDS Interface

NB4N121K

PACKAGE DIMENSIONS

QFN52 8x8, 0.5P
CASE 485M-01
ISSUE C

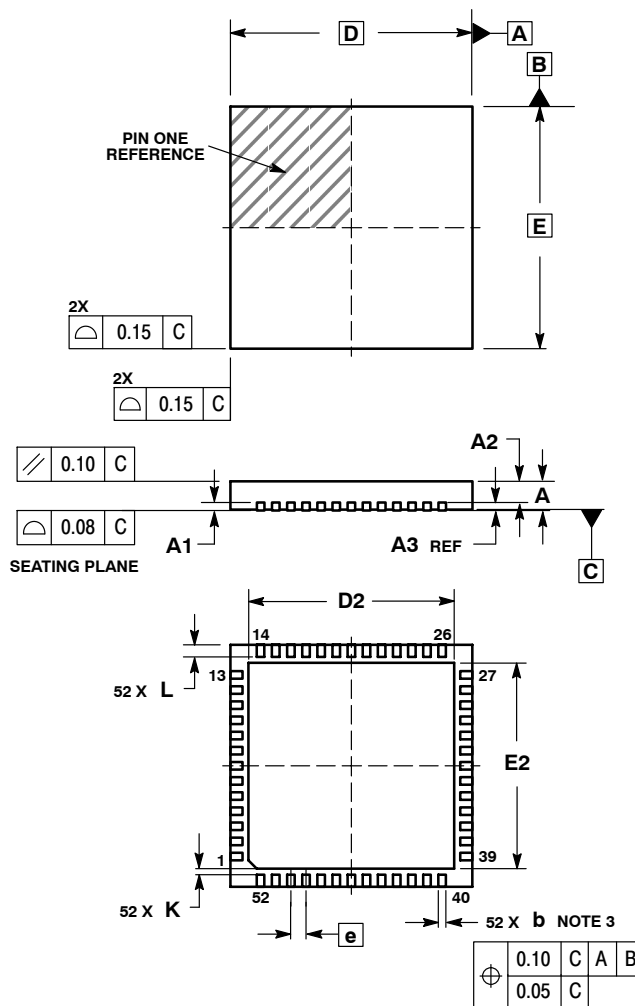

NOTES:

1. DIMENSIONING AND TOLERANCING PER ASME Y14.5M, 1994.
2. CONTROLLING DIMENSION: MILLIMETERS
3. DIMENSION b APPLIES TO PLATED TERMINAL AND IS MEASURED BETWEEN 0.25 AND 0.30 MM FROM TERMINAL.
4. COPLANARITY APPLIES TO THE EXPOSED PAD AS WELL AS THE TERMINALS.

DIM	MILLIMETERS	
	MIN	MAX
A	0.80	1.00
A1	0.00	0.05
A2	0.60	0.80
A3	0.20	REF
b	0.18	0.30
D	8.00	BSC
D2	6.50	6.80
E	8.00	BSC
E2	6.50	6.80
e	0.50	BSC
K	0.20	---
L	0.30	0.50

RECOMMENDED SOLDERING FOOTPRINT*

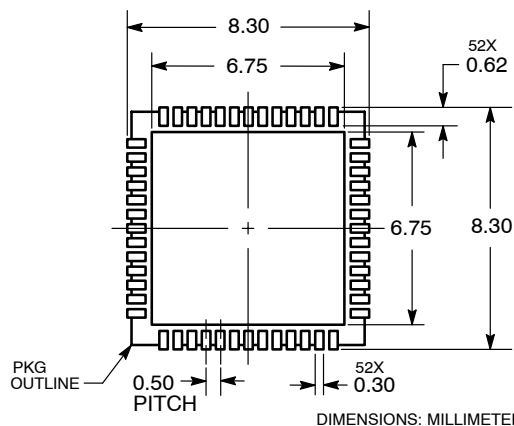

DIMENSIONS: MILLIMETERS

*For additional information on our Pb-Free strategy and soldering details, please download the ON Semiconductor Soldering and Mounting Techniques Reference Manual, SOLDERRM/D.

ON Semiconductor and are registered trademarks of Semiconductor Components Industries, LLC (SCILLC). SCILLC reserves the right to make changes without further notice to any products herein. SCILLC makes no warranty, representation or guarantee regarding the suitability of its products for any particular purpose, nor does SCILLC assume any liability arising out of the application or use of any product or circuit, and specifically disclaims any and all liability, including without limitation special, consequential or incidental damages. "Typical" parameters which may be provided in SCILLC data sheets and/or specifications can and do vary in different applications and actual performance may vary over time. All operating parameters, including "Typicals" must be validated for each customer application by customer's technical experts. SCILLC does not convey any license under its patent rights nor the rights of others. SCILLC products are not designed, intended, or authorized for use as components in systems intended for surgical implant into the body, or other applications intended to support or sustain life, or for any other application in which the failure of the SCILLC product could create a situation where personal injury or death may occur. Should Buyer purchase or use SCILLC products for any such unintended or unauthorized application, Buyer shall indemnify and hold SCILLC and its officers, employees, subsidiaries, affiliates, and distributors harmless against all claims, costs, damages, and expenses, and reasonable attorney fees arising out of, directly or indirectly, any claim of personal injury or death associated with such unintended or unauthorized use, even if such claim alleges that SCILLC was negligent regarding the design or manufacture of the part. SCILLC is an Equal Opportunity/Affirmative Action Employer. This literature is subject to all applicable copyright laws and is not for resale in any manner.

PUBLICATION ORDERING INFORMATION

LITERATURE FULFILLMENT:
Literature Distribution Center for ON Semiconductor
P.O. Box 5163, Denver, Colorado 80217 USA
Phone: 303-675-2175 or 800-344-3860 Toll Free USA/Canada
Fax: 303-675-2176 or 800-344-3867 Toll Free USA/Canada
Email: orderlit@onsemi.com

N. American Technical Support: 800-282-9855 Toll Free
USA/Canada
Europe, Middle East and Africa Technical Support:
Phone: 421 33 790 2910
Japan Customer Focus Center
Phone: 81-3-5773-3850

ON Semiconductor Website: www.onsemi.com
Order Literature: <http://www.onsemi.com/orderlit>

For additional information, please contact your local Sales Representative