



# LC74794, 74794M

## On-Screen Display Controller LSI

### Preliminary

### Overview

The LC74794 and LC74794M are CMOS LSIs for on-screen display, a function that displays characters and patterns on a TV screen under microprocessor control. They feature a built-in PDC/VPS/UDT interface circuit. These LSIs support 12 × 18 dot characters and can display 12 lines by 24 characters of text.

### Features

- Display format: 24 characters by 12 rows (Up to 288 characters)
- Character format: 12 (horizontal) × 18 (vertical) dots
- Character sizes: Three sizes each in the horizontal and vertical directions
- Characters in font: 128
- Initial display positions: 64 horizontal positions and 64 vertical positions
- Blinking: Specifiable in character units
- Blinking types: Two periods supported: 1.0 second and 0.5 second
- Blanking: Over the whole font (12 × 18 dots)
- Background color
  - Background coloring: 8 colors (internal synchronization mode): 4fsc
  - Background coloring: 6 colors (internal synchronization mode): 2fsc
  - Blue background only: NTSC
- Line background color
  - Can be set for 3 lines
  - Line background coloring: 8 colors (internal synchronization mode): 4fsc
  - Line background coloring: 6 colors (internal synchronization mode): 2fsc
- External control input: 8-bit serial input format
- On-chip syne separator and AFC circuits
- PDC/VPS/UDT interface circuit
- Composite video output in the PAL or NTSC format

### Package Dimensions

unit: mm

#### 3196-DIP30SD

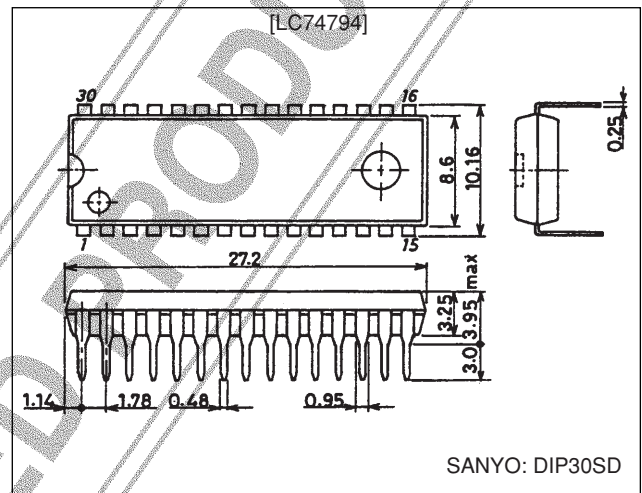

unit: mm

#### 3216A-MFP30S

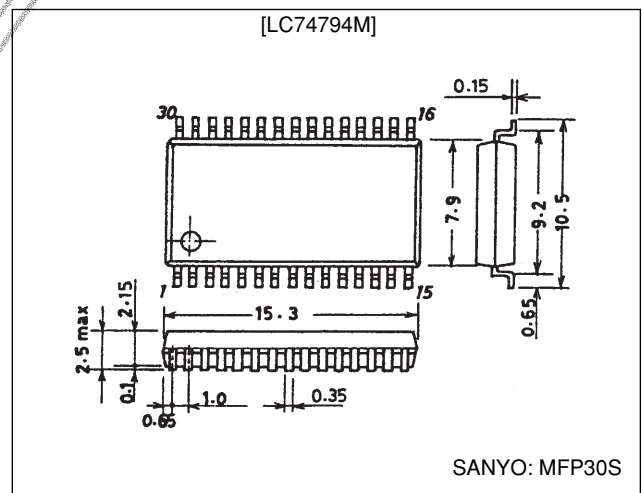

## LC74794, 74794M

### Pin Assignment

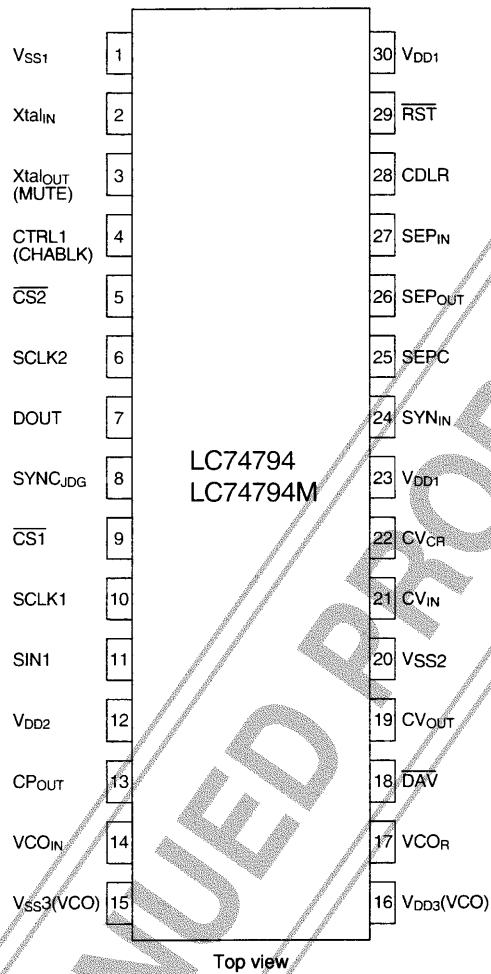

A06346

### Pin Functions

Pin no.	Pin	Function	Notes
1	V <sub>SS1</sub>	Ground	Ground connection (digital system ground)
2	Xtal <sub>IN</sub>		These pins are used either to connect a crystal and capacitor to form an external crystal oscillator to generate internal synchronizing signals, or to input an external clock signal (2fsc or 4fsc). As a mask option, the Xtal <sub>OUT</sub> pin can be set to function as the MUTE input pin. When the MUTE pin is set low, the video output is held at the pedestal level. (A pull-up resistor is built in so the input has hysteresis characteristics.)
3	Xtal <sub>OUT</sub> (MUTE)	Crystal oscillator (MUTE input)	
4	CTRL1 (CHABLK)	Crystal oscillator input switching (CHABLK output)	Switches the mode between external clock input and crystal oscillator operation. A low level selects crystal oscillator operation and a high level selects external clock input. As a mask option, the CTRL1 input pin can be set to function as the CHABLK (character · border) output. This is a 3-value output.
5	CS <sub>2</sub>	Enable input 2	PDC/VPS data output enable input. Data output is enabled by a low-level input. (A pull-up resistor is built in so the input has hysteresis characteristics.)
6	SCLK2	Clock input 2	Clock input for PDC/VPS data output (A pull-up resistor is built in so the input has hysteresis characteristics.)
7	DOUT	Data output	PDC/VPS data output (This is either an n-channel open-drain output or a CMOS output.)
8	SYNC <sub>JDG</sub>	External synchronizing signal judgment output	Outputs the state of the external synchronizing signal presence/absence judgment. Outputs a high level when synchronizing signals are present. Outputs the crystal oscillator clock when CS <sub>1</sub> is low and RST is low. (This signal is not output on command resets.)

Continued on next page.

LC74794, 74794M

Continued from preceding page.

Pin no.	Pin	Function	Notes
9	$\overline{\text{CS1}}$	Enable input 1	Enable input for OSD serial data input Serial data input is enabled by a low-level input. (A pull-up resistor is built in so the input has hysteresis characteristics.)
10	SCLK1	Clock input 1	Serial data clock input (A pull-up resistor is built in so the input has hysteresis characteristics.)
11	SIN1	Data input 1	Serial data input (A pull-up resistor is built in so the input has hysteresis characteristics.)
12	V <sub>DD2</sub>	Power supply	Composite video signal level adjustment power supply (analog system power supply)
13	CP <sub>OUT</sub>	Charge pump output	The charge pump output. Connect a low-pass filter to this pin.
14	VCO <sub>IN</sub>	Oscillator control voltage input	VCO control voltage input
15	V <sub>SS3</sub>	Ground	Ground (VCO ground)
16	V <sub>DD3</sub>	Power supply (+5 V)	Power supply (+5 V: VCO power supply)
17	VCO <sub>R</sub>	Oscillator range adjustment	Connection for the VCO range adjustment resistor
18	$\overline{\text{DAV}}$	Data present output	Outputs a low level when PDC/VPS data has been received.
19	CV <sub>OUT</sub>	Video signal output	Composite video signal output
20	V <sub>SS2</sub>	Ground	Ground (analog system ground)
21	CV <sub>IN</sub>	Video signal input	Composite video signal input
22	CV <sub>CR</sub>	Video signal input	SECAM chrominance signal input
23	V <sub>DD1</sub>	Power supply (+5 V)	Power supply (+5 V: digital system power supply)
24	SYN <sub>IN</sub>	Sync separator circuit input	Internal sync separator circuit video signal input
25	SEPC	Sync separator circuit adjustment	Internal sync separator circuit adjustment input
26	SEP <sub>OUT</sub>	Composite synchronizing signal output	Composite synchronizing signal output for the built-in sync separator circuit. Can be switched to function as an output for the signal (high or ST. pulse) due to MOD0 by setting SEL0 high.
27	SEP <sub>IN</sub>	Vertical synchronizing signal input	Inputs the vertical synchronizing signal created by integrating the SEP <sub>OUT</sub> pin output signal. An integration circuit must be connected to the SEP <sub>OUT</sub> pin. This pin must be tied to V <sub>DD1</sub> if unused.
28	CDLR	Background color phase adjustment	Background color phase adjustment resistor connection
29	$\overline{\text{RST}}$	Reset input	System reset input A pull-up resistor is built in so the input has hysteresis characteristics.
30	V <sub>DD1</sub>	Power supply (+5 V)	Power supply (+5 V: digital system power supply)

DISCONTINUED PRODUCT

## Specifications

### Absolute Maximum Ratings at Ta = 25°C

Parameter	Symbol	Conditions	Ratings	Unit
Supply voltage	V <sub>DD</sub>	V <sub>DD1</sub> and V <sub>DD2</sub>	V <sub>SS</sub> - 0.3 to V <sub>SS</sub> + 7.0	V
Input voltage	V <sub>IN</sub>	All input pins	V <sub>SS</sub> - 0.3 to V <sub>DD</sub> + 0.3	V
Output voltage	V <sub>OUT</sub>	DAV, DOUT, SEP <sub>OUT</sub> , and SYNC <sub>JDG</sub>	V <sub>SS</sub> - 0.3 to V <sub>DD</sub> + 0.3	V
Allowable power dissipation	Pd max		350	mW
Operating temperature	Topr		-30 to +70	°C
Storage temperature	Tstg		-40 to +125	°C

### Allowable Operating Ranges at Ta = -30 to +70°C

Parameter	Symbol	Conditions	Ratings			Unit
			min	typ	max	
Supply voltage	V <sub>DD1</sub>	V <sub>DD1</sub> and V <sub>DD2</sub>	4.5	5.0	5.5	V
	V <sub>DD2</sub>	V <sub>DD2</sub>	5.5	5.0	1.27 V <sub>DD1</sub>	V
Input high-level voltage	V <sub>IH1</sub>	RST, CS1, CS2, SIN1, SCLK1, SCLK2, and MUTE	0.8 V <sub>DD1</sub>		V <sub>DD1</sub> + 0.3	V
	V <sub>IH2</sub>	CTRL1	0.7 V <sub>DD1</sub>		V <sub>DD1</sub> + 0.3	V
Input low-level voltage	V <sub>IL1</sub>	RST, CS1, CS2, SIN1, SCLK1, SCLK2, and MUTE	V <sub>SS</sub> - 0.3		0.2 V <sub>DD1</sub>	V
	V <sub>IL2</sub>	CTRL1	V <sub>SS</sub> - 0.3		0.3 V <sub>DD1</sub>	V
Pull-up resistance	R <sub>PU</sub>	RST, CS1, CS2, SIN1, SCLK1, SCLK2, and MUTE	25	50	90	kΩ
Composite video signal input voltage	V <sub>IN1</sub>	CV <sub>IN</sub> and CV <sub>CR</sub> ; V <sub>DD1</sub> = 5 V		2.0		Vp-p
	V <sub>IN2</sub>	SYN <sub>IN</sub> ; V <sub>DD1</sub> = 5 V	1.5	2.0	2.5	Vp-p
Input voltage	V <sub>IN3</sub>	Xtal <sub>IN</sub> (in external clock input mode) fin = 2 fsc or 4 fsc; V <sub>DD1</sub> = 5 V	0.10		5.0	Vp-p
Oscillator frequency	F <sub>OSC1</sub>	Xtal <sub>IN</sub> and Xtal <sub>OUT</sub> oscillator pins (2 fsc: PAL)		8.867		MHz
	F <sub>OSC2</sub>	Xtal <sub>IN</sub> and Xtal <sub>OUT</sub> oscillator pins (4 fsc: PAL)		17.734		MHz

Note: When the Xtal<sub>IN</sub> pin is used in clock input mode, extreme care must be taken to prevent noise from entering the input signal.

### Electrical Characteristics at Ta = -30 to +70°C, V<sub>DD1</sub> = 5 V unless otherwise specified.

Parameter	Symbol	Conditions	Ratings			Unit
			min	typ	max	
Input off leakage current	I <sub>leak1</sub>	CV <sub>IN</sub> and CV <sub>CR</sub>			1	μA
Output off leakage current	I <sub>leak2</sub>	CV <sub>OUT</sub>			1	μA
Output high-level voltage	V <sub>OH1</sub>	DAV, DOUT, SEP <sub>OUT</sub> , CP <sub>OUT</sub> , SYNC <sub>JDG</sub> ; V <sub>DD1</sub> = 4.5 V, I <sub>OH</sub> = -1.0 mA	3.5			V
Output low-level voltage	V <sub>OL1</sub>	DAV, DOUT, SEP <sub>OUT</sub> , CP <sub>OUT</sub> , SYNC <sub>JDG</sub> ; V <sub>DD1</sub> = 4.5 V, I <sub>OL</sub> = 1.0 mA			1.0	V
Three-value output voltage	V <sub>O</sub>	CHABLK; V <sub>DD1</sub> = 5.0 V H	3.3		5.0	V
		M	1.8		2.3	V
		L	0		0.8	V
Input current	I <sub>IH</sub>	RST, CS1, CS2, SIN, SCLK1, SCLK2, CTRL1, MUTE, SEP <sub>IN</sub> , and VCO <sub>IN</sub> V <sub>IN</sub> = V <sub>DD1</sub>			1	μA
	I <sub>IL</sub>	CTRL1, SEP <sub>IN</sub> , and VCO <sub>IN</sub> ; V <sub>IN</sub> = V <sub>SS1</sub>	-1			μA
Operating current drain	I <sub>DD1</sub>	V <sub>DD1</sub> ; with all outputs open Xtal : 17.734 MHz, VCO : 27 MHz			40	mA
	I <sub>DD2</sub>	V <sub>DD2</sub> ; V <sub>DD2</sub> = 5 V			20	mA
SYNC level	V <sub>SN</sub>	CV <sub>OUT</sub> ; V <sub>DD1</sub> = 5.0 V ①		0.80		V
		V <sub>DD2</sub> = 5.0 V ②		1.00		V
		③		1.30		V
Pedestal level	V <sub>PD</sub>	CV <sub>OUT</sub> ; V <sub>DD1</sub> = 5.0 V ①		1.37		V
		V <sub>DD2</sub> = 5.0 V ②		1.57		V
		③		1.87		V
Color burst low level	V <sub>CBL</sub>	CV <sub>OUT</sub> ; V <sub>DD1</sub> = 5.0 V ①		1.07		V
		V <sub>DD2</sub> = 5.0 V ②		1.27		V
		③		1.57		V

Continued on next page.

LC74794, 74794M

Continued from preceding page.

Parameter	Symbol	Conditions	Ratings			Unit
			min	typ	max	
Color burst high level	V <sub>CBH</sub>	CV <sub>OUT</sub> ; V <sub>DD1</sub> = 5.0 V ①		1.67		V
		V <sub>DD2</sub> = 5.0 V ②		1.87		V
		③		2.17		V
Background color low level	V <sub>RSL</sub>	CV <sub>OUT</sub> ; V <sub>DD1</sub> = 5.0 V ①		1.23 (1.16)		V
		V <sub>DD2</sub> = 5.0 V ②		1.43 (1.36)		V
		③		1.73 (1.66)		V
Background color high level	V <sub>RSH</sub>	CV <sub>OUT</sub> ; V <sub>DD1</sub> = 5.0 V ①		2.37 (2.01)		V
		V <sub>DD2</sub> = 5.0 V ②		2.57 (2.21)		V
		③		2.87 (2.51)		V
Frame level 0	V <sub>BK0</sub>	CV <sub>OUT</sub> ; V <sub>DD1</sub> = 5.0 V ①		1.50		V
		V <sub>DD2</sub> = 5.0 V ②		1.70		V
		③		2.00		V
Frame level 1	V <sub>BK1</sub>	CV <sub>OUT</sub> ; V <sub>DD1</sub> = 5.0 V ①		2.08		V
		V <sub>DD2</sub> = 5.0 V ②		2.28		V
		③		2.58		V
Character level	V <sub>CHA</sub>	CV <sub>OUT</sub> ; V <sub>DD1</sub> = 5.0 V ①		2.65		V
		V <sub>DD2</sub> = 5.0 V ②		2.85		V
		③		3.15		V

Notes: ① When the sync level is 0.8 V.  
 ② When the sync level is 1.0 V.  
 ③ When the sync level is 1.3 V.

The values in parentheses for the background color high and low levels are the values for a blue background.

**Timing Characteristics at Ta = -30 to +70°C, V<sub>DD1</sub> = 5 ± 0.5 V**

OSD write (See Figure 1.)

Parameter	Symbol	Conditions	Ratings			Unit
			min	typ	max	
Minimum input pulse width	t <sub>w</sub> (SCLK)	SCLK1	200			ns
	t <sub>w</sub> (CS1)	CS1 (The period when CS1 is high)	1			μs
Data setup time	t <sub>SU</sub> (CS1)	CS1	200			ns
	t <sub>SU</sub> (SIN)	SIN1	200			ns
Data hold time	t <sub>h</sub> (CS1)	CS1	2			μs
	t <sub>h</sub> (SIN)	SIN1	200			ns
One word write time	t <sub>word</sub>	The time to write 8 bits of data	4.2			μs
	t <sub>wt</sub>	The RAM data write time	1			μs

PDC/VPS reads (For the n-channel open-drain output circuit. See Figure 2.)

Parameter	Symbol	Conditions	Ratings			Unit
			min	typ	max	
Minimum input pulse width	t <sub>CKCY</sub>	SCLK2	2			μs
	t <sub>CKL</sub>	SCLK2	1			μs
	t <sub>CKH</sub>	SCLK2	1			μs
Setup time	t <sub>ICK</sub>	SCLK2	10			μs
Output delay time	t <sub>CKO</sub>	DOUT			0.5	μs

Note: Timings follow those for OSD write when the CMOS output circuit is used.

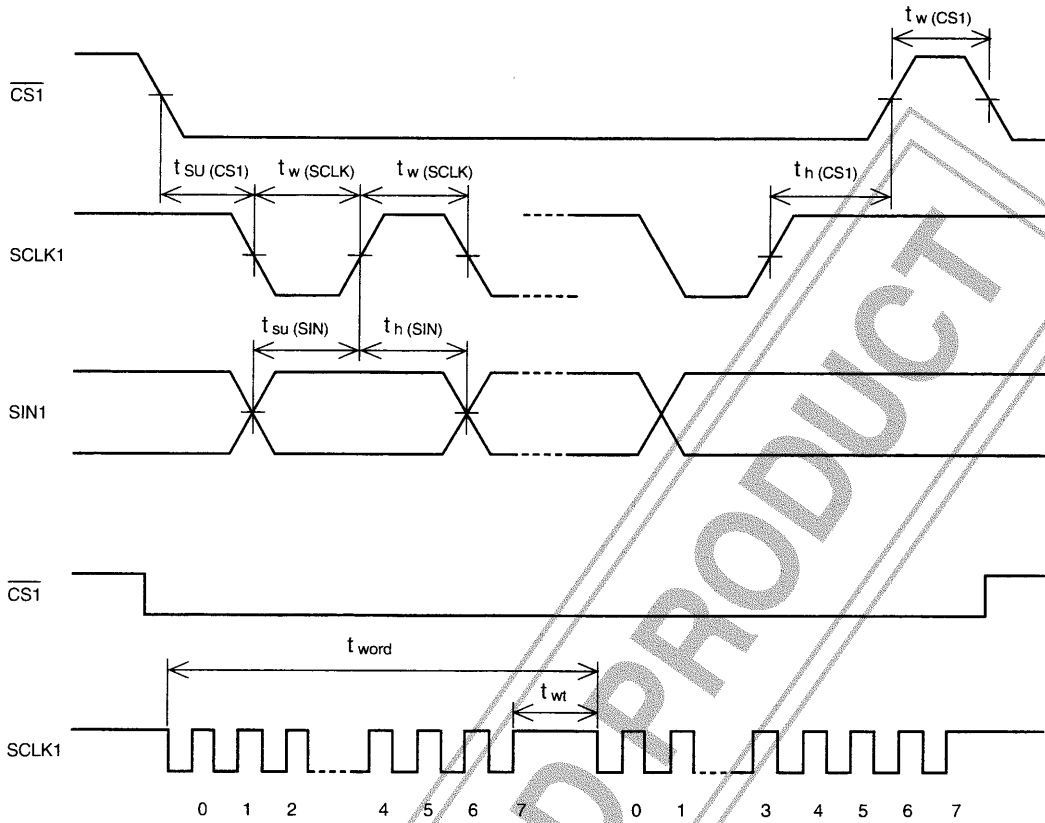

A06347

Figure 1 OSD Serial Data Input Timing

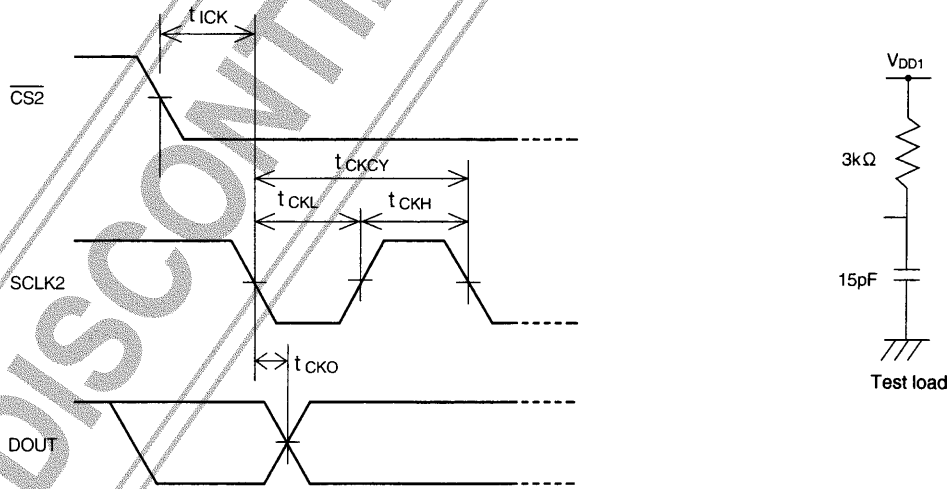

A06348

Note: DOUT goes to the high-impedance state while  $\overline{CS2}$  is high.

Figure 2 PDC/VPS Serial Output Test Conditions (For the n-channel open-drain output)



**Display Control Commands**

Display control commands have an 8-bit format and are transferred using the serial input function. Commands consist of a command identification code in the first byte and command data in the following bytes. The following commands are supported.

- 1 COMMAND0: Display memory (VRAM) write address setup command
- 2 COMMAND1: Display character data write command
- 3 COMMAND2: Vertical display start position and vertical character size setup command
- 4 COMMAND3: Horizontal display start position and horizontal character size setup command
- 5 COMMAND4: Display control setup command
- 6 COMMAND5: Display control setup command
- 7 COMMAND6: Synchronizing signal detection setup command
- 8 COMMAND7 to COMMAND12: Display control setup commands
- 9 COMMAND13 to COMMAND17: VPS/PDC commands

**Display Control Command Table**

Command	First byte								Second byte							
	Command identification code				Data				Data							
	7	6	5	4	3	2	1	0	7	6	5	4	3	2	1	0
COMMAND0 Write address setup	1	0	0	0	V3	V2	V1	V0	0	0	0	H4	H3	H2	H1	H0
COMMAND1 Character write	1	0	0	1	0	0	0	0	at	c6	c5	c4	c3	c2	c1	c0
COMMAND2 Vertical character size and vertical display start position	1	0	1	0	VS 21	VS 20	VS 11	VS 10	0	FS	VP 5	VP 4	VP 3	VP 2	VP 1	VP 0
COMMAND3 Horizontal character size and horizontal display start position	1	0	1	1	HS 21	HS 20	HS 11	HS 10	0		HP 5	HP 4	HP 3	HP 2	HP 1	HP 0
COMMAND4 Display control	1	1	0	0	TST MOD	RAM ERS	OSC STP	SYS RST	0	BLK 2	BLK 1	BLK 0	BK 1	BK 0	RV	DSP ON
COMMAND5 Display control	1	1	0	1	NP1	NP0	NON	INT	0	0	HLF INT	BCL	CB	PH 2	PH 1	PH 0
COMMAND6 Synchronizing signal detection	1	1	1	0	SEL 0	MOD 0	DIS LIN	MUT	0	RN 2	RN 1	RN 0	SN 3	SN 2	SN 1	SN 0
COMMAND7 Display control	1	1	1	1	0	0	0	0	0	CIN SEL	CIN CTL	VNP SEL	VSP SEL	MSK ERS	MSK SEL	EGL
COMMAND8 Display control	1	1	1	1	0	0	0	1	0	LNA 3	LNA 2	LNA 1	LNA 0	LPA 2	LPA 1	LPA 0
COMMAND9 Display control	1	1	1	1	0	0	1	0	0	LNB 3	LNB 2	LNB 1	LNB 0	LPB 2	LPB 1	LPB 0
COMMAND10 Display control	1	1	1	1	0	0	1	1	0	LNC 3	LNC 2	LNC 1	LNC 0	LPC 2	LPC 1	LPC 0
COMMAND11 Display control	1	1	1	1	0	1	0	0	0	0	0	0	LNC SEL	MOD 3	LNB SEL	MOD 2
COMMAND12 Display control	1	1	1	1	0	1	0	1	0	0	0	0	0	SEL 2	SEL 1	CTL 3
COMMAND13 VPS/PDC control	1	1	1	1	0	1	1	0	0	CPA 1	CPA 0	0	VPM 3	VPM 2	VPM 1	VPM 0
COMMAND14 VPS/PDC control	1	1	1	1	0	1	1	1	0	0	0	HBS 2	HBS 1	BMS	EMS	DCE
COMMAND15 VPS/PDC control	1	1	1	1	1	0	0	0	0	0	ECV 15	ECV 14	ECV 13	ECV 12	ECV 11	ECV 5
COMMAND16 VPS/PDC control	1	1	1	1	1	0	0	1	0	ECP 19	ECP 18	ECP 17	ECP 16	ECP 15	ECP 14	ECP 13
COMMAND17 VPS/PDC control	1	1	1	1	1	0	1	0	0	0	ECP 25	ECP 24	ECP 23	ECP 22	ECP 21	ECP 20

Once written, the command identification code in the first byte is stored until the next first byte is written. However, when the display character data write command (COMMAND1) is written, the LC74794/M locks into the display character data write mode, and another first byte cannot be written.

When the  $\overline{CS1}$  pin is set high, the LC74794/M is set to the COMMAND0 (display memory write address setup mode) state.

## LC74794, 74794M

### COMMAND0 (Display memory write address setup command)

#### First byte

DA 0 to 7	Register	Contents		Notes
		State	Function	
7	—	1		
6	—	0	Command 0 identification code Sets the display memory write address.	
5	—	0		
4	—	0		
3	V3	0	Display memory line address (0 to B hexadecimal)	
		1		
2	V2	0		
		1		
1	V1	0		
		1		
0	V0	0		
		1		

#### Second byte

DA 0 to 7	Register	Contents		Notes
		State	Function	
7	—	0	Second byte identification code	
6	—	0		
5	—	0		
4	H4	0	Display memory column address (0 to 17 hexadecimal)	
		1		
3	H3	0		
		1		
2	H2	0		
		1		
1	H1	0		
		1		
0	H0	0		
		1		

Note: All registers are set to 0 when the LC74794/M is reset by the RST pin.

### COMMAND1 (Display character data write setup command)

#### First byte

DA 0 to 7	Register	Contents		Notes
		State	Function	
7	—	1		
6	—	0	Command 1 identification code Sets up display character data write mode.	When this command is input, the LC74794/M locks in the display character data write mode until the CS1 pin goes high.
5	—	0		
4	—	1		
3	—	0		
2	—	0		
1	—	0		
0	—	0		

LC74794, 74794M

Second byte

DA 0 to 7	Register	Contents		Notes
		State	Function	
7	at	0	Character attribute off	
		1	Character attribute on	
6	c6	0	Character code (00 to 7F hexadecimal)	
		1		
5	c5	0		
		1		
4	c4	0		
		1		
3	c3	0		
		1		
2	c2	0		
		1		
1	c1	0		
		1		
0	c0	0		
		1		

Note: All registers are set to 0 when the LC74794/M is reset by the RST pin.

COMMAND2 (Vertical display start position and vertical character size setup command)

First byte

DA 0 to 7	Register	Contents		Notes									
		State	Function										
7	—	1	Command 2 identification code Sets the vertical display start position and the vertical character size										
6	—	0											
5	—	1											
4	—	0											
3	VS21	0	<table border="1"> <tr> <td>VS21 \ VS20</td> <td>0</td> <td>1</td> </tr> <tr> <td>0</td> <td>1H/dot</td> <td>2H/dot</td> </tr> <tr> <td>1</td> <td>3H/dot</td> <td>1H/dot</td> </tr> </table>	VS21 \ VS20	0	1	0	1H/dot	2H/dot	1	3H/dot	1H/dot	Second line vertical character size
		VS21 \ VS20		0	1								
0	1H/dot	2H/dot											
1	3H/dot	1H/dot											
1													
2	VS20	0	<table border="1"> <tr> <td>VS11 \ VS10</td> <td>0</td> <td>1</td> </tr> <tr> <td>0</td> <td>1H/dot</td> <td>2H/dot</td> </tr> <tr> <td>1</td> <td>3H/dot</td> <td>1H/dot</td> </tr> </table>	VS11 \ VS10	0	1	0	1H/dot	2H/dot	1	3H/dot	1H/dot	First line vertical character size
		VS11 \ VS10		0	1								
0	1H/dot	2H/dot											
1	3H/dot	1H/dot											
1													
1	VS11	0	<table border="1"> <tr> <td>VS11 \ VS10</td> <td>0</td> <td>1</td> </tr> <tr> <td>0</td> <td>1H/dot</td> <td>2H/dot</td> </tr> <tr> <td>1</td> <td>3H/dot</td> <td>1H/dot</td> </tr> </table>	VS11 \ VS10	0	1	0	1H/dot	2H/dot	1	3H/dot	1H/dot	
		VS11 \ VS10		0	1								
0	1H/dot	2H/dot											
1	3H/dot	1H/dot											
1													
0	VS10	0	<table border="1"> <tr> <td>VS11 \ VS10</td> <td>0</td> <td>1</td> </tr> <tr> <td>0</td> <td>1H/dot</td> <td>2H/dot</td> </tr> <tr> <td>1</td> <td>3H/dot</td> <td>1H/dot</td> </tr> </table>	VS11 \ VS10	0	1	0	1H/dot	2H/dot	1	3H/dot	1H/dot	
		VS11 \ VS10		0	1								
0	1H/dot	2H/dot											
1	3H/dot	1H/dot											
1													

Second byte

DA 0 to 7	Register	Contents		Notes
		State	Function	
7	—	0	Second byte identification bit	
6	FS	0	Crystal oscillator frequency: 2fsc	
		1	Crystal oscillator frequency: 4fsc	
5	VP5 (MSB)	0	If VS is the vertical display start position then: $VS = H \times (2 \sum_{n=0}^5 VP_n)$ H: the horizontal synchronization pulse period	The vertical display start position is set by the 6 bits VP0 to VP5. The weight of bit 1 is 2H.
		1		
4	VP4	0		
		1		
3	VP3	0		
		1		
2	VP2	0		
		1		
1	VP1	0		
		1		
0	VP0 (LSB)	0		
		1		

**LC74794, 74794M**

**COMMAND3 (Horizontal display start position and horizontal size setup command)**

**First byte**

DA 0 to 7	Register	Contents		Notes									
		State	Function										
7	—	1	Command 3 identification code Sets the horizontal display start position and the horizontal character size.										
6	—	0											
5	—	1											
4	—	1											
3	HS21	0	<table border="1"> <tr> <td>HS21 \ HS20</td> <td>0</td> <td>1</td> </tr> <tr> <td>0</td> <td>1Tc/dot</td> <td>2Tc/dot</td> </tr> <tr> <td>1</td> <td>3Tc/dot</td> <td>1Tc/dot</td> </tr> </table>	HS21 \ HS20	0	1	0	1Tc/dot	2Tc/dot	1	3Tc/dot	1Tc/dot	Second line horizontal character size
		HS21 \ HS20		0	1								
0	1Tc/dot	2Tc/dot											
1	3Tc/dot	1Tc/dot											
1													
2	HS20	0	<table border="1"> <tr> <td>HS11 \ HS10</td> <td>0</td> <td>1</td> </tr> <tr> <td>0</td> <td>1Tc/dot</td> <td>2Tc/dot</td> </tr> <tr> <td>1</td> <td>3Tc/dot</td> <td>1Tc/dot</td> </tr> </table>	HS11 \ HS10	0	1	0	1Tc/dot	2Tc/dot	1	3Tc/dot	1Tc/dot	First line horizontal character size
		HS11 \ HS10		0	1								
0	1Tc/dot	2Tc/dot											
1	3Tc/dot	1Tc/dot											
1													
1	HS11	0	<table border="1"> <tr> <td>HS11 \ HS10</td> <td>0</td> <td>1</td> </tr> <tr> <td>0</td> <td>1Tc/dot</td> <td>2Tc/dot</td> </tr> <tr> <td>1</td> <td>3Tc/dot</td> <td>1Tc/dot</td> </tr> </table>	HS11 \ HS10	0	1	0	1Tc/dot	2Tc/dot	1	3Tc/dot	1Tc/dot	
		HS11 \ HS10		0	1								
0	1Tc/dot	2Tc/dot											
1	3Tc/dot	1Tc/dot											
1													
0	HS10	0	<table border="1"> <tr> <td>HS11 \ HS10</td> <td>0</td> <td>1</td> </tr> <tr> <td>0</td> <td>1Tc/dot</td> <td>2Tc/dot</td> </tr> <tr> <td>1</td> <td>3Tc/dot</td> <td>1Tc/dot</td> </tr> </table>	HS11 \ HS10	0	1	0	1Tc/dot	2Tc/dot	1	3Tc/dot	1Tc/dot	
		HS11 \ HS10		0	1								
0	1Tc/dot	2Tc/dot											
1	3Tc/dot	1Tc/dot											
1													

**Second byte**

DA 0 to 7	Register	Contents		Notes
		State	Function	
7	—	0	Second byte identification bit	
6	—	0		
5	HP5 (MSB)	0	If HS is the horizontal start position then: $HS = Tc \times (2 \sum_{n=0}^5 HP_n)$ Tc: Period of the oscillator connected to OSCIN/OSCOUT in operating mode.	The horizontal display start position is set by the 6 bits HP0 to HP5. The weight of bit 1 is 2Tc.
		1		
4	HP4	0		
		1		
3	HP3	0		
		1		
2	HP2	0		
		1		
1	HP1	0		
		1		
0	HP0 (LSB)	0		
		1		

Note: All registers are set to 0 when the LC74794/M is reset by the RST pin.

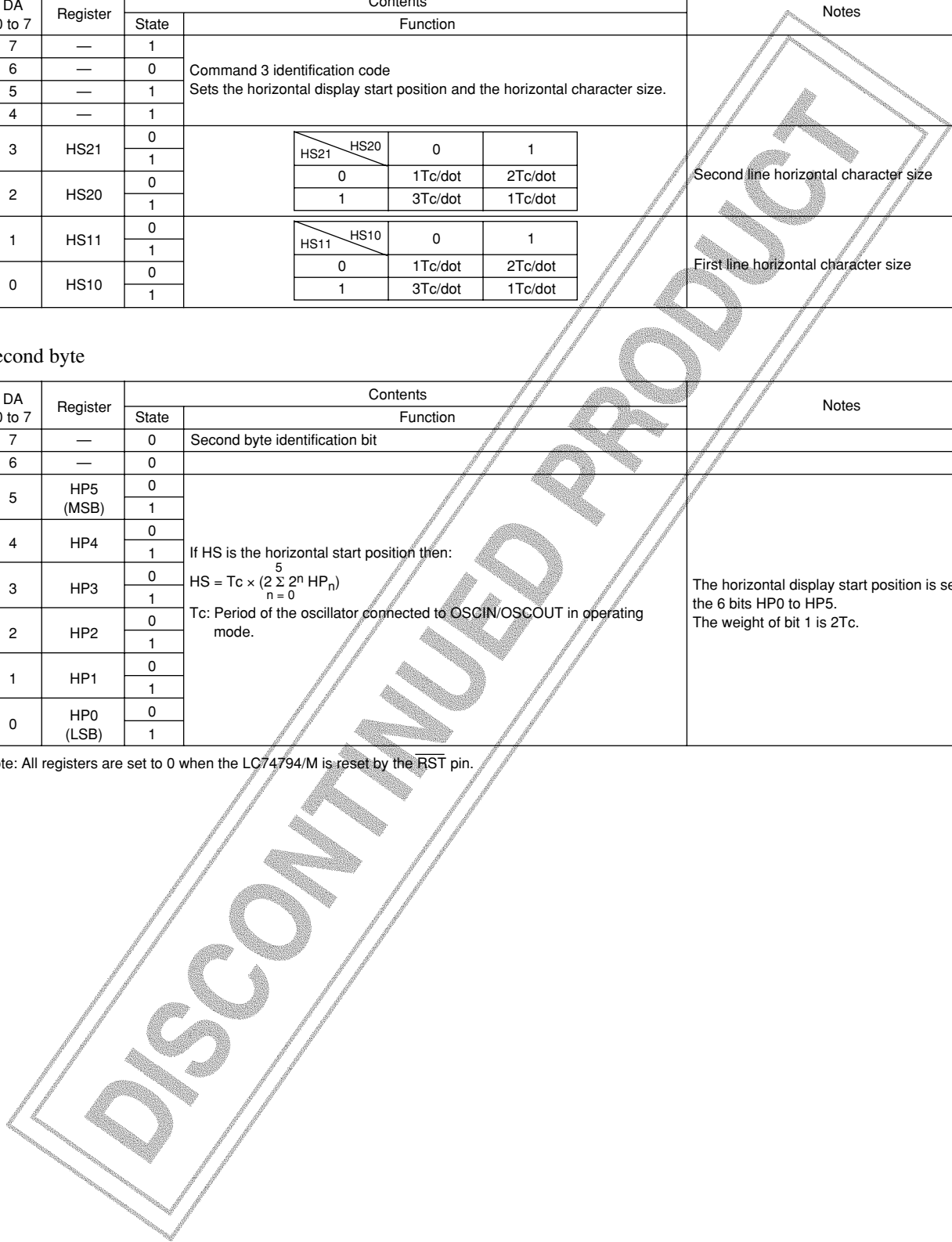

LC74794, 74794M

COMMAND4 (Display control setup command)

First byte

DA 0 to 7	Register	Contents		Notes
		State	Function	
7	—	1	Command 4 identification code Display control setup	
6	—	1		
5	—	0		
4	—	0		
3	TSTMOD	0	Normal operating mode	This bit must be set to 0.
		1	Test mode	
2	RAMERS	0	Erase display RAM. (Set the RAM data to 7F hexadecimal.)	Erasing RAM takes about 500 μs. (This operation must be executed in the DSPOFF state.)
		1		
1	OSCSTP	0	Do not stop the crystal and LC oscillators.	Valid in external synchronization mode when character display is off.
		1	Stop the crystal and LC oscillators.	
0	SYSRST	0	Reset all registers and turn display off.	The registers are reset when the CS1 pin is low, and the reset state is cleared when CS1 is set high.
		1		

Second byte

DA 0 to 7	Register	Contents		Notes												
		State	Function													
7	—	0	Second byte identification bit													
6	BLK2	0	Character display area	Specifies the size for complete fill-in												
		1	Video display area													
5	BLK1	0	<table border="1" style="display: inline-table; vertical-align: middle;"> <tr> <td></td> <td>BLK0</td> <td>0</td> <td>1</td> </tr> <tr> <td>0</td> <td></td> <td>Blanking off</td> <td>Character size</td> </tr> <tr> <td>1</td> <td></td> <td>Border size</td> <td>Complete fill in</td> </tr> </table>		BLK0	0	1	0		Blanking off	Character size	1		Border size	Complete fill in	Changes the blanking size
				BLK0	0	1										
0		Blanking off	Character size													
1		Border size	Complete fill in													
1																
4	BLK0	0														
		1														
3	BK1	0	Blinking period: About 0.5 s	Switches the blinking period												
		1	Blinking period: About 1.0 s													
2	BK0	0	Blinking off	Blinking in reverse video mode switches the display between normal character display and reverse video display.												
		1	Blinking on													
1	RV	0	Reverse video off													
		1	Reverse video on													
0	DSPON	0	Character display off													
		1	Character display on													

Note: All registers are set to 0 when the LC74794/M is reset by the RST pin.

LC74794, 74794M

COMMAND5 (Display control setup command)

First byte

DA 0 to 7	Register	Contents		Notes															
		State	Function																
7	—	1	Command 5 identification code Display control setup																
6	—	1																	
5	—	0																	
4	—	1																	
3	NP1	0	<table border="1"> <tr> <td></td> <td>NPP1</td> <td>NP0</td> <td>0</td> <td>1</td> </tr> <tr> <td>0</td> <td>0</td> <td>0</td> <td>NTSC (525)</td> <td>NTSC (625)</td> </tr> <tr> <td>1</td> <td>0</td> <td>1</td> <td>PAL (525)</td> <td>PAL (625)</td> </tr> </table>		NPP1	NP0	0	1	0	0	0	NTSC (525)	NTSC (625)	1	0	1	PAL (525)	PAL (625)	Switches between NTSC and PAL ( ) external input V
				NPP1	NP0	0	1												
0	0	0		NTSC (525)	NTSC (625)														
1	0	1		PAL (525)	PAL (625)														
1																			
2	NP0	0																	
		1																	
1	NON	1	Interlaced	Switches between interlaced and noninterlaced video.															
		0	Noninterlaced																
0	INT	0	External synchronization	Switches between external and internal synchronization															
		1	Internal synchronization																

Second byte

DA 0 to 7	Register	Contents		Notes																																				
		State	Function																																					
7	—	0	Second byte identification bit																																					
6	—	0																																						
5	HLFINT	0	Normal mode																																					
		1	No background coloring (Only the background level is set)																																					
4	BCL	0	Background coloring on	Only valid in internal synchronization mode.																																				
		1	No background coloring (Only the background level is set)																																					
3	CB	0	Color burst signal output	Only valid when BCL is high.																																				
		1	Color burst signal output stopped																																					
2	PH2	0	<table border="1"> <thead> <tr> <th>PH2</th> <th>PH1</th> <th>PH0</th> <th>Background color (phase)</th> </tr> </thead> <tbody> <tr> <td>0</td> <td>0</td> <td>0</td> <td>Cyan *</td> </tr> <tr> <td>0</td> <td>0</td> <td>1</td> <td>Yellow *</td> </tr> <tr> <td>0</td> <td>1</td> <td>0</td> <td>Red *</td> </tr> <tr> <td>0</td> <td>1</td> <td>1</td> <td>Blue *</td> </tr> <tr> <td>1</td> <td>0</td> <td>0</td> <td>Cyan - blue</td> </tr> <tr> <td>1</td> <td>0</td> <td>1</td> <td>Green *</td> </tr> <tr> <td>1</td> <td>1</td> <td>0</td> <td>Orange</td> </tr> <tr> <td>1</td> <td>1</td> <td>1</td> <td>Magenta *</td> </tr> </tbody> </table>	PH2	PH1	PH0	Background color (phase)	0	0	0	Cyan *	0	0	1	Yellow *	0	1	0	Red *	0	1	1	Blue *	1	0	0	Cyan - blue	1	0	1	Green *	1	1	0	Orange	1	1	1	Magenta *	Background color specification
		PH2		PH1	PH0	Background color (phase)																																		
0	0	0		Cyan *																																				
0	0	1		Yellow *																																				
0	1	0		Red *																																				
0	1	1		Blue *																																				
1	0	0		Cyan - blue																																				
1	0	1		Green *																																				
1	1	0		Orange																																				
1	1	1		Magenta *																																				
1																																								
1	PH1	0																																						
		1																																						
0	PH0	0																																						
		1																																						

\*: When 2 fsc is used.

Note: All registers are set to 0 when the LC74794/M is reset by the RST pin.

## LC74794, 74794M

### COMMAND6 (Synchronizing signal detection setup command)

#### First byte

DA 0 to 7	Register	Contents		Notes
		State	Function	
7	—	1	Command 6 identification code Sets up synchronizing signal control.	
6	—	1		
5	—	1		
4	—	0		
3	SEL0	0	Sync separator signal	Switches the SEP <sub>OUT</sub> (pin 19) output.
		1	Output signal set by MOD0	
2	MOD0	0	High-level output	Only valid when SEL0 is high.
		1	ST pulse signal	
1	DISLIN	0	12 lines	Switches the number of lines displayed.
		1	10 lines	
0	MUT	0	Normal output	CV <sub>OUT</sub> switching
		1	CV <sub>IN</sub> is cut and CV <sub>OUT</sub> is held at the pedestal level.	

#### Second byte

DA 0 to 7	Register	Contents		Notes																														
		State	Function																															
7	—	0	Second byte identification bit																															
6	RN2	0	<table border="1"> <thead> <tr> <th>RN2</th> <th>RN1</th> <th>RN0</th> <th>Number of times HSYNC detected</th> </tr> </thead> <tbody> <tr> <td>0</td> <td>0</td> <td>0</td> <td>0 times</td> </tr> <tr> <td>0</td> <td>0</td> <td>1</td> <td>4 times</td> </tr> <tr> <td>0</td> <td>1</td> <td>0</td> <td>8 times</td> </tr> <tr> <td>1</td> <td>0</td> <td>0</td> <td>16 times</td> </tr> </tbody> </table>	RN2	RN1	RN0	Number of times HSYNC detected	0	0	0	0 times	0	0	1	4 times	0	1	0	8 times	1	0	0	16 times	External synchronizing signal detection control Signal absent → signal present transition detection Sets the sampling period in which SYNC can be detected continuously in the horizontal synchronizing signal period (1H).										
		RN2		RN1	RN0	Number of times HSYNC detected																												
0	0	0		0 times																														
0	0	1		4 times																														
0	1	0	8 times																															
1	0	0	16 times																															
1																																		
5	RN1	0																																
		1																																
4	RN0	0	<table border="1"> <thead> <tr> <th>SN3</th> <th>SN2</th> <th>SN1</th> <th>SN0</th> <th>Number of times HSYNC detected</th> </tr> </thead> <tbody> <tr> <td>0</td> <td>0</td> <td>0</td> <td>0</td> <td>Not detected</td> </tr> <tr> <td>0</td> <td>0</td> <td>0</td> <td>1</td> <td>32 times</td> </tr> <tr> <td>0</td> <td>0</td> <td>1</td> <td>0</td> <td>64 times</td> </tr> <tr> <td>0</td> <td>1</td> <td>0</td> <td>0</td> <td>128 times</td> </tr> <tr> <td>1</td> <td>0</td> <td>0</td> <td>0</td> <td>256 times</td> </tr> </tbody> </table>	SN3	SN2	SN1	SN0	Number of times HSYNC detected	0	0	0	0	Not detected	0	0	0	1	32 times	0	0	1	0	64 times	0	1	0	0	128 times	1	0	0	0	256 times	External synchronizing signal detection control Signal present → signal absent transition detection Sets the sampling period in which SYNC cannot be detected continuously in the horizontal synchronizing signal period (1H).
		SN3		SN2	SN1	SN0	Number of times HSYNC detected																											
0	0	0		0	Not detected																													
0	0	0		1	32 times																													
0	0	1	0	64 times																														
0	1	0	0	128 times																														
1	0	0	0	256 times																														
1																																		
3	SN3	0																																
		1																																
2	SN2	0																																
		1																																
1	SN1	0																																
		1																																
0	SN0	0																																
		1																																

Note: All registers are set to 0 when the LC74794/M is reset by the  $\overline{\text{RST}}$  pin.

COMMAND7 (Display control setup command)

First byte

DA 0 to 7	Register	Contents		Notes
		State	Function	
7	—	1	Command 7 identification code Display control setup	
6	—	1		
5	—	1		
4	—	1		
3	—	0	Extended command 0 identification code	
2	—	0		
1	—	0		
0	—	0		

Second byte

DA 0 to 7	Register	Contents		Notes
		State	Function	
7	—	0	Second byte identification bit	
6	CINSEL	0	Blank area (the logical OR of the character and frame signals)	CV <sub>CR</sub> on signal switching
		1	Video signal display area	
5	CINCTL	0	CV <sub>CR</sub> : off	Turns CV <sub>CR</sub> on or off.
		1	CV <sub>CR</sub> : on	
4	VNPSEL	0	V falling edge detection	Switches the V acquisition polarity in external mode when internal V separation is used.
		1	V rising edge detection	
3	VSPSEL	0	VSEP: about 8.9 μs (NTSC)	Switches the internal V separation period.
		1	VSEP: about 17.8 μs (NTSC)	
2	MSKERS	0	Mask valid	Clears the HSYNC and VSYNC masks.
		1	Mask invalid	
1	MSKSEL	0	3H (NTSC)	Switches the VSYNC mask.
		1	20H (NTSC)	
0	EGL	0	Border level 0 only (VBK0)	Switches the border level. (Only valid when BLK0 is 0 and BLK1 is 1.)
		1	Two-stage border level (VBK0 and VBK1)	

Note: All registers are set to 0 when the LC74794/M is reset by the RST pin.

DISCONTINUED PRODUCT

LC74794, 74794M

COMMAND8 (Display control setup command)

First byte

DA 0 to 7	Register	Contents		Notes
		State	Function	
7	—	1	Command 7 identification code Display control setup	
6	—	1		
5	—	1		
4	—	1		
3	—	0	Extended command 1 identification code	
2	—	0		
1	—	0		
0	—	1		

Second byte

DA 0 to 7	Register	Contents		Notes																																																																						
		State	Function																																																																							
7	—	0	Second byte identification bit																																																																							
6	LNA3	0	<table border="1"> <thead> <tr> <th>LNA3</th> <th>LNA2</th> <th>LNA1</th> <th>LNA0</th> <th>Specified line</th> </tr> </thead> <tbody> <tr> <td>0</td> <td>0</td> <td>0</td> <td>0</td> <td>Do not change the line background</td> </tr> <tr> <td>0</td> <td>0</td> <td>0</td> <td>1</td> <td>Line 1</td> </tr> <tr> <td>0</td> <td>0</td> <td>1</td> <td>0</td> <td>Line 2</td> </tr> <tr> <td>0</td> <td>0</td> <td>1</td> <td>1</td> <td>Line 3</td> </tr> <tr> <td>0</td> <td>1</td> <td>0</td> <td>0</td> <td>Line 4</td> </tr> <tr> <td>0</td> <td>1</td> <td>0</td> <td>1</td> <td>Line 5</td> </tr> <tr> <td>0</td> <td>1</td> <td>1</td> <td>0</td> <td>Line 6</td> </tr> <tr> <td>0</td> <td>1</td> <td>1</td> <td>1</td> <td>Line 7</td> </tr> <tr> <td>1</td> <td>0</td> <td>0</td> <td>0</td> <td>Line 8</td> </tr> <tr> <td>1</td> <td>0</td> <td>0</td> <td>1</td> <td>Line 9</td> </tr> <tr> <td>1</td> <td>0</td> <td>1</td> <td>0</td> <td>Line 10</td> </tr> <tr> <td>1</td> <td>0</td> <td>1</td> <td>1</td> <td>Line 11</td> </tr> <tr> <td>1</td> <td>1</td> <td>—</td> <td>—</td> <td>Line 12</td> </tr> </tbody> </table>	LNA3	LNA2	LNA1	LNA0	Specified line	0	0	0	0	Do not change the line background	0	0	0	1	Line 1	0	0	1	0	Line 2	0	0	1	1	Line 3	0	1	0	0	Line 4	0	1	0	1	Line 5	0	1	1	0	Line 6	0	1	1	1	Line 7	1	0	0	0	Line 8	1	0	0	1	Line 9	1	0	1	0	Line 10	1	0	1	1	Line 11	1	1	—	—	Line 12	Specifies the line whose background is to be changed (Specifying the same line with LNA*, LNB*, and LNC* is not allowed.)
		LNA3		LNA2	LNA1	LNA0	Specified line																																																																			
0	0	0		0	Do not change the line background																																																																					
0	0	0		1	Line 1																																																																					
0	0	1		0	Line 2																																																																					
0	0	1		1	Line 3																																																																					
0	1	0		0	Line 4																																																																					
0	1	0		1	Line 5																																																																					
0	1	1		0	Line 6																																																																					
0	1	1		1	Line 7																																																																					
1	0	0		0	Line 8																																																																					
1	0	0		1	Line 9																																																																					
1	0	1	0	Line 10																																																																						
1	0	1	1	Line 11																																																																						
1	1	—	—	Line 12																																																																						
1	1	0	0	Line 1																																																																						
5	LNA2	0	<table border="1"> <thead> <tr> <th>LPA2</th> <th>LPA1</th> <th>LPA0</th> <th>Background color (phase)</th> </tr> </thead> <tbody> <tr> <td>0</td> <td>0</td> <td>0</td> <td>Cyan *</td> </tr> <tr> <td>0</td> <td>0</td> <td>1</td> <td>Yellow *</td> </tr> <tr> <td>0</td> <td>1</td> <td>0</td> <td>Red *</td> </tr> <tr> <td>0</td> <td>1</td> <td>1</td> <td>Blue *</td> </tr> <tr> <td>1</td> <td>0</td> <td>0</td> <td>Cyan - blue</td> </tr> <tr> <td>1</td> <td>0</td> <td>1</td> <td>Green *</td> </tr> <tr> <td>1</td> <td>1</td> <td>0</td> <td>Orange</td> </tr> <tr> <td>1</td> <td>1</td> <td>1</td> <td>Magenta *</td> </tr> </tbody> </table>	LPA2	LPA1	LPA0	Background color (phase)	0	0	0	Cyan *	0	0	1	Yellow *	0	1	0	Red *	0	1	1	Blue *	1	0	0	Cyan - blue	1	0	1	Green *	1	1	0	Orange	1	1	1	Magenta *	Specifies the background color.																																		
		LPA2		LPA1	LPA0	Background color (phase)																																																																				
0	0	0		Cyan *																																																																						
0	0	1		Yellow *																																																																						
0	1	0		Red *																																																																						
0	1	1		Blue *																																																																						
1	0	0		Cyan - blue																																																																						
1	0	1		Green *																																																																						
1	1	0		Orange																																																																						
1	1	1		Magenta *																																																																						
1	1	0		0	Cyan *																																																																					
4	LNA1	0		<table border="1"> <thead> <tr> <th>LPA2</th> <th>LPA1</th> <th>LPA0</th> <th>Background color (phase)</th> </tr> </thead> <tbody> <tr> <td>0</td> <td>0</td> <td>0</td> <td>Cyan *</td> </tr> <tr> <td>0</td> <td>0</td> <td>1</td> <td>Yellow *</td> </tr> <tr> <td>0</td> <td>1</td> <td>0</td> <td>Red *</td> </tr> <tr> <td>0</td> <td>1</td> <td>1</td> <td>Blue *</td> </tr> <tr> <td>1</td> <td>0</td> <td>0</td> <td>Cyan - blue</td> </tr> <tr> <td>1</td> <td>0</td> <td>1</td> <td>Green *</td> </tr> <tr> <td>1</td> <td>1</td> <td>0</td> <td>Orange</td> </tr> <tr> <td>1</td> <td>1</td> <td>1</td> <td>Magenta *</td> </tr> </tbody> </table>	LPA2	LPA1	LPA0	Background color (phase)	0	0	0	Cyan *	0	0	1	Yellow *	0	1	0	Red *	0	1	1	Blue *	1	0	0	Cyan - blue	1	0	1	Green *	1	1	0	Orange	1	1	1		Magenta *	Specifies the background color.																																
		LPA2	LPA1		LPA0	Background color (phase)																																																																				
0	0	0	Cyan *																																																																							
0	0	1	Yellow *																																																																							
0	1	0	Red *																																																																							
0	1	1	Blue *																																																																							
1	0	0	Cyan - blue																																																																							
1	0	1	Green *																																																																							
1	1	0	Orange																																																																							
1	1	1	Magenta *																																																																							
1	1	0	0		Cyan *																																																																					
3	LNA0	0	<table border="1"> <thead> <tr> <th>LPA2</th> <th>LPA1</th> <th>LPA0</th> <th>Background color (phase)</th> </tr> </thead> <tbody> <tr> <td>0</td> <td>0</td> <td>0</td> <td>Cyan *</td> </tr> <tr> <td>0</td> <td>0</td> <td>1</td> <td>Yellow *</td> </tr> <tr> <td>0</td> <td>1</td> <td>0</td> <td>Red *</td> </tr> <tr> <td>0</td> <td>1</td> <td>1</td> <td>Blue *</td> </tr> <tr> <td>1</td> <td>0</td> <td>0</td> <td>Cyan - blue</td> </tr> <tr> <td>1</td> <td>0</td> <td>1</td> <td>Green *</td> </tr> <tr> <td>1</td> <td>1</td> <td>0</td> <td>Orange</td> </tr> <tr> <td>1</td> <td>1</td> <td>1</td> <td>Magenta *</td> </tr> </tbody> </table>		LPA2	LPA1	LPA0	Background color (phase)	0	0	0	Cyan *	0	0	1	Yellow *	0	1	0	Red *	0	1	1	Blue *	1	0	0	Cyan - blue	1	0	1	Green *	1	1	0	Orange	1	1	1	Magenta *	Specifies the background color.																																	
		LPA2		LPA1	LPA0	Background color (phase)																																																																				
0	0	0		Cyan *																																																																						
0	0	1		Yellow *																																																																						
0	1	0		Red *																																																																						
0	1	1		Blue *																																																																						
1	0	0		Cyan - blue																																																																						
1	0	1		Green *																																																																						
1	1	0		Orange																																																																						
1	1	1		Magenta *																																																																						
1	1	0		0	Cyan *																																																																					
2	LPA2	0		<table border="1"> <thead> <tr> <th>LPA2</th> <th>LPA1</th> <th>LPA0</th> <th>Background color (phase)</th> </tr> </thead> <tbody> <tr> <td>0</td> <td>0</td> <td>0</td> <td>Cyan *</td> </tr> <tr> <td>0</td> <td>0</td> <td>1</td> <td>Yellow *</td> </tr> <tr> <td>0</td> <td>1</td> <td>0</td> <td>Red *</td> </tr> <tr> <td>0</td> <td>1</td> <td>1</td> <td>Blue *</td> </tr> <tr> <td>1</td> <td>0</td> <td>0</td> <td>Cyan - blue</td> </tr> <tr> <td>1</td> <td>0</td> <td>1</td> <td>Green *</td> </tr> <tr> <td>1</td> <td>1</td> <td>0</td> <td>Orange</td> </tr> <tr> <td>1</td> <td>1</td> <td>1</td> <td>Magenta *</td> </tr> </tbody> </table>	LPA2	LPA1	LPA0	Background color (phase)	0	0	0	Cyan *	0	0	1	Yellow *	0	1	0	Red *	0	1	1	Blue *	1	0	0	Cyan - blue	1	0	1	Green *	1	1	0	Orange	1	1	1	Magenta *		Specifies the background color.																																
		LPA2	LPA1		LPA0	Background color (phase)																																																																				
0	0	0	Cyan *																																																																							
0	0	1	Yellow *																																																																							
0	1	0	Red *																																																																							
0	1	1	Blue *																																																																							
1	0	0	Cyan - blue																																																																							
1	0	1	Green *																																																																							
1	1	0	Orange																																																																							
1	1	1	Magenta *																																																																							
1	1	0	0		Cyan *																																																																					
1	LPA1	0	<table border="1"> <thead> <tr> <th>LPA2</th> <th>LPA1</th> <th>LPA0</th> <th>Background color (phase)</th> </tr> </thead> <tbody> <tr> <td>0</td> <td>0</td> <td>0</td> <td>Cyan *</td> </tr> <tr> <td>0</td> <td>0</td> <td>1</td> <td>Yellow *</td> </tr> <tr> <td>0</td> <td>1</td> <td>0</td> <td>Red *</td> </tr> <tr> <td>0</td> <td>1</td> <td>1</td> <td>Blue *</td> </tr> <tr> <td>1</td> <td>0</td> <td>0</td> <td>Cyan - blue</td> </tr> <tr> <td>1</td> <td>0</td> <td>1</td> <td>Green *</td> </tr> <tr> <td>1</td> <td>1</td> <td>0</td> <td>Orange</td> </tr> <tr> <td>1</td> <td>1</td> <td>1</td> <td>Magenta *</td> </tr> </tbody> </table>		LPA2	LPA1	LPA0	Background color (phase)	0	0	0	Cyan *	0	0	1	Yellow *	0	1	0	Red *	0	1	1	Blue *	1	0	0	Cyan - blue	1	0	1	Green *	1	1	0	Orange	1	1	1	Magenta *	Specifies the background color.																																	
		LPA2		LPA1	LPA0	Background color (phase)																																																																				
0	0	0		Cyan *																																																																						
0	0	1		Yellow *																																																																						
0	1	0		Red *																																																																						
0	1	1		Blue *																																																																						
1	0	0		Cyan - blue																																																																						
1	0	1		Green *																																																																						
1	1	0		Orange																																																																						
1	1	1		Magenta *																																																																						
1	1	0		0	Cyan *																																																																					
0	LPA0	0		<table border="1"> <thead> <tr> <th>LPA2</th> <th>LPA1</th> <th>LPA0</th> <th>Background color (phase)</th> </tr> </thead> <tbody> <tr> <td>0</td> <td>0</td> <td>0</td> <td>Cyan *</td> </tr> <tr> <td>0</td> <td>0</td> <td>1</td> <td>Yellow *</td> </tr> <tr> <td>0</td> <td>1</td> <td>0</td> <td>Red *</td> </tr> <tr> <td>0</td> <td>1</td> <td>1</td> <td>Blue *</td> </tr> <tr> <td>1</td> <td>0</td> <td>0</td> <td>Cyan - blue</td> </tr> <tr> <td>1</td> <td>0</td> <td>1</td> <td>Green *</td> </tr> <tr> <td>1</td> <td>1</td> <td>0</td> <td>Orange</td> </tr> <tr> <td>1</td> <td>1</td> <td>1</td> <td>Magenta *</td> </tr> </tbody> </table>	LPA2	LPA1	LPA0	Background color (phase)	0	0	0	Cyan *	0	0	1	Yellow *	0	1	0	Red *	0	1	1	Blue *	1	0	0	Cyan - blue	1	0	1	Green *	1	1	0	Orange	1	1	1	Magenta *		Specifies the background color.																																
		LPA2	LPA1		LPA0	Background color (phase)																																																																				
0	0	0	Cyan *																																																																							
0	0	1	Yellow *																																																																							
0	1	0	Red *																																																																							
0	1	1	Blue *																																																																							
1	0	0	Cyan - blue																																																																							
1	0	1	Green *																																																																							
1	1	0	Orange																																																																							
1	1	1	Magenta *																																																																							
1	1	0	0		Cyan *																																																																					

Note: All registers are set to 0 when the LC74794/M is reset by the RST pin.

LC74794, 74794M

COMMAND9 (Display control setup command)

First byte

DA 0 to 7	Register	Contents		Notes
		State	Function	
7	—	1	Command 7 identification code Display control setup	
6	—	1		
5	—	1		
4	—	1		
3	—	0	Extended command 2 identification code	
2	—	0		
1	—	1		
0	—	0		

Second byte

DA 0 to 7	Register	Contents		Notes																																																																						
		State	Function																																																																							
7	—	0	Second byte identification bit																																																																							
6	LNB3	0	<table border="1"> <thead> <tr> <th>LNB3</th> <th>LNB2</th> <th>LNB1</th> <th>LNB0</th> <th>Specified line</th> </tr> </thead> <tbody> <tr> <td>0</td> <td>0</td> <td>0</td> <td>0</td> <td>Do not change the line background</td> </tr> <tr> <td>0</td> <td>0</td> <td>0</td> <td>1</td> <td>Line 1</td> </tr> <tr> <td>0</td> <td>0</td> <td>1</td> <td>0</td> <td>Line 2</td> </tr> <tr> <td>0</td> <td>0</td> <td>1</td> <td>1</td> <td>Line 3</td> </tr> <tr> <td>0</td> <td>1</td> <td>0</td> <td>0</td> <td>Line 4</td> </tr> <tr> <td>0</td> <td>1</td> <td>0</td> <td>1</td> <td>Line 5</td> </tr> <tr> <td>0</td> <td>1</td> <td>1</td> <td>0</td> <td>Line 6</td> </tr> <tr> <td>0</td> <td>1</td> <td>1</td> <td>1</td> <td>Line 7</td> </tr> <tr> <td>1</td> <td>0</td> <td>0</td> <td>0</td> <td>Line 8</td> </tr> <tr> <td>1</td> <td>0</td> <td>0</td> <td>1</td> <td>Line 9</td> </tr> <tr> <td>1</td> <td>0</td> <td>1</td> <td>0</td> <td>Line 10</td> </tr> <tr> <td>1</td> <td>0</td> <td>1</td> <td>1</td> <td>Line 11</td> </tr> <tr> <td>1</td> <td>1</td> <td>—</td> <td>—</td> <td>Line 12</td> </tr> </tbody> </table>	LNB3	LNB2	LNB1	LNB0	Specified line	0	0	0	0	Do not change the line background	0	0	0	1	Line 1	0	0	1	0	Line 2	0	0	1	1	Line 3	0	1	0	0	Line 4	0	1	0	1	Line 5	0	1	1	0	Line 6	0	1	1	1	Line 7	1	0	0	0	Line 8	1	0	0	1	Line 9	1	0	1	0	Line 10	1	0	1	1	Line 11	1	1	—	—	Line 12	Specifies the line whose background is to be changed. (Specifying the same line with LNA*, LNB*, and LNC* is not allowed.)
		LNB3		LNB2	LNB1	LNB0	Specified line																																																																			
0	0	0		0	Do not change the line background																																																																					
0	0	0		1	Line 1																																																																					
0	0	1		0	Line 2																																																																					
0	0	1		1	Line 3																																																																					
0	1	0		0	Line 4																																																																					
0	1	0		1	Line 5																																																																					
0	1	1		0	Line 6																																																																					
0	1	1		1	Line 7																																																																					
1	0	0		0	Line 8																																																																					
1	0	0		1	Line 9																																																																					
1	0	1	0	Line 10																																																																						
1	0	1	1	Line 11																																																																						
1	1	—	—	Line 12																																																																						
1	1																																																																									
5	LNB2	0																																																																								
		1																																																																								
4	LNB1	0																																																																								
		1																																																																								
3	LNB0	0																																																																								
		1																																																																								
2	LPB2	0	<table border="1"> <thead> <tr> <th>LPB2</th> <th>LPB1</th> <th>LPB0</th> <th>Background color (phase)</th> </tr> </thead> <tbody> <tr> <td>0</td> <td>0</td> <td>0</td> <td>Cyan *</td> </tr> <tr> <td>0</td> <td>0</td> <td>1</td> <td>Yellow *</td> </tr> <tr> <td>0</td> <td>1</td> <td>0</td> <td>Red *</td> </tr> <tr> <td>0</td> <td>1</td> <td>1</td> <td>Blue *</td> </tr> <tr> <td>1</td> <td>0</td> <td>0</td> <td>Cyan - blue</td> </tr> <tr> <td>1</td> <td>0</td> <td>1</td> <td>Green *</td> </tr> <tr> <td>1</td> <td>1</td> <td>0</td> <td>Orange</td> </tr> <tr> <td>1</td> <td>1</td> <td>1</td> <td>Magenta *</td> </tr> </tbody> </table>	LPB2	LPB1	LPB0	Background color (phase)	0	0	0	Cyan *	0	0	1	Yellow *	0	1	0	Red *	0	1	1	Blue *	1	0	0	Cyan - blue	1	0	1	Green *	1	1	0	Orange	1	1	1	Magenta *	Specifies the background color.  *: When 2 fsc is used.																																		
		LPB2		LPB1	LPB0	Background color (phase)																																																																				
0	0	0		Cyan *																																																																						
0	0	1		Yellow *																																																																						
0	1	0		Red *																																																																						
0	1	1		Blue *																																																																						
1	0	0		Cyan - blue																																																																						
1	0	1		Green *																																																																						
1	1	0		Orange																																																																						
1	1	1		Magenta *																																																																						
1	1																																																																									
1	LPB1	0																																																																								
		1																																																																								
0	LPB0	0																																																																								
		1																																																																								

Note: All registers are set to 0 when the LC74794/M is reset by the RST pin.

LC74794, 74794M

COMMAND10 (Display control setup command)

First byte

DA 0 to 7	Register	Contents		Notes
		State	Function	
7	—	1	Command 7 identification code Display control setup	
6	—	1		
5	—	1		
4	—	1		
3	—	0	Extended command 3 identification code	
2	—	0		
1	—	1		
0	—	1		

Second byte

DA 0 to 7	Register	Contents		Notes																																																																						
		State	Function																																																																							
7	—	0	Second byte identification bit																																																																							
6	LNC3	0	<table border="1"> <thead> <tr> <th>LNC3</th> <th>LNC2</th> <th>LNC1</th> <th>LNC0</th> <th>Specified line</th> </tr> </thead> <tbody> <tr> <td>0</td> <td>0</td> <td>0</td> <td>0</td> <td>Do not change the line background</td> </tr> <tr> <td>0</td> <td>0</td> <td>0</td> <td>1</td> <td>Line 1</td> </tr> <tr> <td>0</td> <td>0</td> <td>1</td> <td>0</td> <td>Line 2</td> </tr> <tr> <td>0</td> <td>0</td> <td>1</td> <td>1</td> <td>Line 3</td> </tr> <tr> <td>0</td> <td>1</td> <td>0</td> <td>0</td> <td>Line 4</td> </tr> <tr> <td>0</td> <td>1</td> <td>0</td> <td>1</td> <td>Line 5</td> </tr> <tr> <td>0</td> <td>1</td> <td>1</td> <td>0</td> <td>Line 6</td> </tr> <tr> <td>0</td> <td>1</td> <td>1</td> <td>1</td> <td>Line 7</td> </tr> <tr> <td>1</td> <td>0</td> <td>0</td> <td>0</td> <td>Line 8</td> </tr> <tr> <td>1</td> <td>0</td> <td>0</td> <td>1</td> <td>Line 9</td> </tr> <tr> <td>1</td> <td>0</td> <td>1</td> <td>0</td> <td>Line 10</td> </tr> <tr> <td>1</td> <td>0</td> <td>1</td> <td>1</td> <td>Line 11</td> </tr> <tr> <td>1</td> <td>1</td> <td>—</td> <td>—</td> <td>Line 12</td> </tr> </tbody> </table>	LNC3	LNC2	LNC1	LNC0	Specified line	0	0	0	0	Do not change the line background	0	0	0	1	Line 1	0	0	1	0	Line 2	0	0	1	1	Line 3	0	1	0	0	Line 4	0	1	0	1	Line 5	0	1	1	0	Line 6	0	1	1	1	Line 7	1	0	0	0	Line 8	1	0	0	1	Line 9	1	0	1	0	Line 10	1	0	1	1	Line 11	1	1	—	—	Line 12	Specifies the line whose background is to be changed. (Specifying the same line with LNA*, LNB*, and LNC* is not allowed.)
		LNC3		LNC2	LNC1	LNC0	Specified line																																																																			
0	0	0		0	Do not change the line background																																																																					
0	0	0		1	Line 1																																																																					
0	0	1		0	Line 2																																																																					
0	0	1		1	Line 3																																																																					
0	1	0		0	Line 4																																																																					
0	1	0		1	Line 5																																																																					
0	1	1		0	Line 6																																																																					
0	1	1		1	Line 7																																																																					
1	0	0		0	Line 8																																																																					
1	0	0		1	Line 9																																																																					
1	0	1	0	Line 10																																																																						
1	0	1	1	Line 11																																																																						
1	1	—	—	Line 12																																																																						
1	1	0	0	Line 1																																																																						
1	1	0	1	Line 2																																																																						
1	1	1	0	Line 3																																																																						
1	1	1	1	Line 4																																																																						
1	0	0	0	Line 5																																																																						
1	0	0	1	Line 6																																																																						
1	0	1	0	Line 7																																																																						
1	0	1	1	Line 8																																																																						
1	0	1	0	Line 9																																																																						
1	0	1	1	Line 10																																																																						
1	1	—	—	Line 11																																																																						
1	1	—	—	Line 12																																																																						
2	LPC2	0	<table border="1"> <thead> <tr> <th>LPC2</th> <th>LPC1</th> <th>LPC0</th> <th>Background color (phase)</th> </tr> </thead> <tbody> <tr> <td>0</td> <td>0</td> <td>0</td> <td>Cyan *</td> </tr> <tr> <td>0</td> <td>0</td> <td>1</td> <td>Yellow *</td> </tr> <tr> <td>0</td> <td>1</td> <td>0</td> <td>Red *</td> </tr> <tr> <td>0</td> <td>1</td> <td>1</td> <td>Blue *</td> </tr> <tr> <td>1</td> <td>0</td> <td>0</td> <td>Cyan - blue</td> </tr> <tr> <td>1</td> <td>0</td> <td>1</td> <td>Green *</td> </tr> <tr> <td>1</td> <td>1</td> <td>0</td> <td>Orange</td> </tr> <tr> <td>1</td> <td>1</td> <td>1</td> <td>Magenta *</td> </tr> </tbody> </table>	LPC2	LPC1	LPC0	Background color (phase)	0	0	0	Cyan *	0	0	1	Yellow *	0	1	0	Red *	0	1	1	Blue *	1	0	0	Cyan - blue	1	0	1	Green *	1	1	0	Orange	1	1	1	Magenta *	Specifies the background color.																																		
		LPC2		LPC1	LPC0	Background color (phase)																																																																				
0	0	0		Cyan *																																																																						
0	0	1		Yellow *																																																																						
0	1	0		Red *																																																																						
0	1	1		Blue *																																																																						
1	0	0		Cyan - blue																																																																						
1	0	1		Green *																																																																						
1	1	0		Orange																																																																						
1	1	1		Magenta *																																																																						
1	1	0		Cyan *																																																																						
1	1	1		Yellow *																																																																						
1	0	0	Red *																																																																							
1	0	1	Blue *																																																																							
1	1	0	Cyan - blue																																																																							
1	1	1	Green *																																																																							
1	0	0	Orange																																																																							
1	0	1	Magenta *																																																																							
1	1	0	Cyan *																																																																							
1	1	1	Yellow *																																																																							
1	0	0	Red *																																																																							
1	0	1	Blue *																																																																							
1	1	0	Cyan - blue																																																																							
1	1	1	Green *																																																																							
1	0	0	Orange																																																																							
1	0	1	Magenta *																																																																							
0	LPC0	0	<p style="text-align: center;">*: When 2 fsc is used.</p>																																																																							
1		1																																																																								

Note: All registers are set to 0 when the LC74794/M is reset by the RST pin.

LC74794, 74794M

COMMAND11 (Display control setup command)

First byte

DA 0 to 7	Register	Contents		Notes
		State	Function	
7	—	1	Command 7 identification code Display control setup	
6	—	1		
5	—	1		
4	—	1		
3	—	0	Extended command 4 identification code	
2	—	1		
1	—	0		
0	—	0		

Second byte

DA 0 to 7	Register	Contents		Notes
		State	Function	
7	—	0	Second byte identification bit	
6	—	0		
5	—	0		
4	—	0		
3	LNCSEL	0	Normal line background color operation	Switches the background color in RV mode for RV specified characters on LNB* specified lines.
		1	RV characters have the color of the PH* specified background color and RV characters have a white background.	
2	MOD3	0	The specifications when LNCSEL is set to 1.	Valid when LNCSEL is high.
		1	RV characters have the background color specified by PH* and the RV characters themselves are white.	
1	LNBSEL	0	Normal line background color operation	Switches the background color in RV mode for RV specified characters on LNB* specified lines.
		1	RV characters have the color of the PH* specified background color and RV characters have a white background.	
0	MOD2	0	The specifications when LNBSEL is set to 1.	Valid when LNBSEL is high.
		1	RV characters have the background color specified by PH* and the RV characters themselves are white.	

Note: All registers are set to 0 when the LC74794/M is reset by the RST pin.

DISCONTINUED PRODUCT

## LC74794, 74794M

### COMMAND12 (Display control setup command)

#### First byte

DA 0 to 7	Register	Contents		Notes
		State	Function	
7	—	1	Command 7 identification code Display control setup	
6	—	1		
5	—	1		
4	—	1		
3	—	0	Extended command 5 identification code	
2	—	1		
1	—	0		
0	—	1		

#### Second byte

DA 0 to 7	Register	Contents		Notes
		State	Function	
7	—	0	Second byte identification bit	
6	—	0		
5	—	0		
4	—	0		
3	—	0		
2	SEL2	0	External synchronizing signal judgment output signal	SYNCJDG (pin 8) output switching
		1	O/E signal	
1	SEL1	0	Internal slice data	Signal input from SEP <sub>IN</sub> (pin 27) when set to 1
		1	External slice data	
0	CTL3	0	Use internal V separation.	V separation switching
		1	Do not use internal V separation.	

Note: All registers are set to 0 when the LC74794/M is reset by the RST pin.

LC74794, 74794M

COMMAND13 (VPS/PDC control setup command)

First byte

DA 0 to 7	Register	Contents		Notes
		State	Function	
7	—	1	Command 7 identification code Display control setup	
6	—	1		
5	—	1		
4	—	1		
3	—	0	Extended command 6 identification code	
2	—	1		
1	—	1		
0	—	0		

Second byte

DA 0 to 7	Register	Contents		Notes																																																																							
		State	Function																																																																								
7	—	0	Second byte identification bit																																																																								
6	CPA1	0	<table border="1"> <thead> <tr> <th>CPA1</th> <th>CPA0</th> <th>Clock</th> </tr> </thead> <tbody> <tr> <td>0</td> <td>0</td> <td>No.1</td> </tr> <tr> <td>0</td> <td>1</td> <td>No.2</td> </tr> <tr> <td>1</td> <td>0</td> <td>No.3</td> </tr> <tr> <td>1</td> <td>1</td> <td>No.4</td> </tr> </tbody> </table>	CPA1	CPA0	Clock	0	0	No.1	0	1	No.2	1	0	No.3	1	1	No.4	Data acquisition clock switching																																																								
		CPA1		CPA0	Clock																																																																						
0	0	No.1																																																																									
0	1	No.2																																																																									
1	0	No.3																																																																									
1	1	No.4																																																																									
1																																																																											
5	CPA0	0																																																																									
		1																																																																									
4	—	0																																																																									
3	VPM3	0	<table border="1"> <thead> <tr> <th>VPM3</th> <th>VPM2</th> <th>VPM1</th> <th>VPM0</th> <th>Operating mode</th> </tr> </thead> <tbody> <tr> <td>0</td> <td>0</td> <td>0</td> <td>0</td> <td>VPS</td> </tr> <tr> <td>0</td> <td>0</td> <td>0</td> <td>1</td> <td>8/30/2 (PDC)</td> </tr> <tr> <td>0</td> <td>0</td> <td>1</td> <td>0</td> <td>Automatic PDC and VPS switching</td> </tr> <tr> <td>0</td> <td>0</td> <td>1</td> <td>1</td> <td>8/30/1 (UDT)</td> </tr> <tr> <td rowspan="2">2</td> <td rowspan="2">VPM2</td> <td>0</td> <td>0</td> <td>1</td> <td>0</td> <td>Header time 1</td> </tr> <tr> <td>0</td> <td>1</td> <td>0</td> <td>0</td> <td>Header time 2</td> </tr> <tr> <td rowspan="2">1</td> <td rowspan="2">VPM1</td> <td>0</td> <td>0</td> <td>1</td> <td>0</td> <td>Header time 3</td> </tr> <tr> <td>0</td> <td>1</td> <td>1</td> <td>1</td> <td>Header time 4</td> </tr> <tr> <td rowspan="4">0</td> <td rowspan="4">VPM0</td> <td>1</td> <td>0</td> <td>0</td> <td>0</td> <td>Status display 1</td> </tr> <tr> <td>1</td> <td>0</td> <td>0</td> <td>1</td> <td>Status display 2</td> </tr> <tr> <td>1</td> <td>0</td> <td>1</td> <td>0</td> <td>Status display 3</td> </tr> <tr> <td>1</td> <td>0</td> <td>1</td> <td>1</td> <td>Status display 4</td> </tr> </tbody> </table>	VPM3	VPM2	VPM1	VPM0	Operating mode	0	0	0	0	VPS	0	0	0	1	8/30/2 (PDC)	0	0	1	0	Automatic PDC and VPS switching	0	0	1	1	8/30/1 (UDT)	2	VPM2	0	0	1	0	Header time 1	0	1	0	0	Header time 2	1	VPM1	0	0	1	0	Header time 3	0	1	1	1	Header time 4	0	VPM0	1	0	0	0	Status display 1	1	0	0	1	Status display 2	1	0	1	0	Status display 3	1	0	1	1	Status display 4	
		VPM3		VPM2	VPM1	VPM0	Operating mode																																																																				
0	0	0		0	VPS																																																																						
0	0	0		1	8/30/2 (PDC)																																																																						
0	0	1		0	Automatic PDC and VPS switching																																																																						
0	0	1		1	8/30/1 (UDT)																																																																						
2	VPM2	0		0	1	0	Header time 1																																																																				
		0		1	0	0	Header time 2																																																																				
1	VPM1	0		0	1	0	Header time 3																																																																				
		0		1	1	1	Header time 4																																																																				
0	VPM0	1		0	0	0	Status display 1																																																																				
		1		0	0	1	Status display 2																																																																				
		1		0	1	0	Status display 3																																																																				
		1		0	1	1	Status display 4																																																																				
1																																																																											
0																																																																											
1																																																																											

Note: All registers are set to 0 when the LC74794/M is reset by the RST pin.

LC74794, 74794M

COMMAND14 (VPS/PDC control setup command)

First byte

DA 0 to 7	Register	Contents		Notes
		State	Function	
7	—	1		
6	—	1	Command 7 identification code Display control setup	
5	—	1		
4	—	1		
3	—	0		
2	—	1	Extended command 7 identification code	
1	—	1		
0	—	1		

Second byte

DA 0 to 7	Register	Contents		Notes
		State	Function	
7	—	0	Second byte identification bit	
6	—	0		
5	—	0		
4	HBS2	0	Discrimination mode 1	Clock line
		1	Discrimination mode 2	
3	HBS1	0	Discrimination mode 1	Framing code
		1	Discrimination mode 2	
2	BMS	0	Error checking enabled (Error checking can be turned on or off on a per-byte basis.)	When 0, bytes for which error checking is specified and that have no errors are written to P-S. When 1, all bytes are written to P-S regardless of errors.
		1	Error checking disabled (Applications can select whether to hold or write data with errors on a per-byte basis.)	
1	EMS	0	Data hold	The handling of bytes for which error checking is turned off when error checking is enabled.
		1	Data write (In VPS mode, the error bit is set to 0.)	
0	DCE	0	Error checking turned on for data unused bytes. VPS: bytes 3, 4, and 6 to 10. PDCC (8/30/2): bytes 7 to 12. Header 1: bytes 14 to 37. Header 2: bytes 14 to 29. Header 3: bytes 14 to 21. Status 1 (3): bytes 7 to 25. Status 2 (4): bytes 7 to 35.	Error checking specification for bytes whose data is unused. Bi-phase (VPS), Hamming (PDC), or odd parity (header)
		1	Error checking turned off for data unused bytes. VPS: bytes 3, 4, and 6 to 10. PDCC (8/30/2): bytes 7 to 12. Header 1: bytes 14 to 37. Header 2: bytes 14 to 29. Header 3: bytes 14 to 21. Status 1 (3): bytes 7 to 25. Status 2 (4): bytes 7 to 35.	

Note: All registers are set to 0 when the LC74794/M is reset by the RST pin.

COMMAND15 (VPS/PDC control setup command)

First byte

DA 0 to 7	Register	Contents		Notes
		State	Function	
7	—	1	Command 7 identification code Display control setup	
6	—	1		
5	—	1		
4	—	1		
3	—	1	Extended command 8 identification code	
2	—	0		
1	—	0		
0	—	0		

Second byte

DA 0 to 7	Register	Contents		Notes
		State	Function	
7	—	0	Second byte identification bit	
6	—	0		
5	ECV15	0	Byte 15 bi-phase error check on (data held)	Settings when the VPS data BMS = 0. Settings in parentheses apply when BMS = 1.
		1	Byte 15 bi-phase error check off (data written)	
4	ECV14	0	Byte 14 bi-phase error check on (data held)	
		1	Byte 14 bi-phase error check off (data written)	
3	ECV13	0	Byte 13 bi-phase error check on (data held)	
		1	Byte 13 bi-phase error check off (data written)	
2	ECV12	0	Byte 12 bi-phase error check on (data held)	
		1	Byte 12 bi-phase error check off (data written)	
1	ECV11	0	Byte 11 bi-phase error check on (data held)	
		1	Byte 11 bi-phase error check off (data written)	
0	ECV5	0	Byte 5 bi-phase error check on (data held)	
		1	Byte 5 bi-phase error check off (data written)	

Note: All registers are set to 0 when the LC74794/M is reset by the RST pin.

DISCONTINUED PRODUCT

COMMAND16 (VPS/PDC control setup command)

First byte

DA 0 to 7	Register	Contents		Notes
		State	Function	
7	—	1		
6	—	1	Command 7 identification code Display control setup	
5	—	1		
4	—	1		
3	—	1		
2	—	0	Extended command 9 identification code	
1	—	0		
0	—	1		

Second byte

DA 0 to 7	Register	Contents		Notes
		State	Function	
7	—	0	Second byte identification bit	
6	ECP19	0	Byte 19 Hamming error check on (data held) {Byte 44, 28, 36, 20, 32, 42, 32, and 42}	Settings when the PDC data (8/30/2) BMS = 0. Settings in parentheses apply when BMS = 1. The items in curly brackets are the bytes for which the odd parity check is turned on and off in header modes 1, 2, 3, and 4 and status modes 1, 2, 3, and 4, respectively.
		1	Byte 19 Hamming error check off (data written) {Byte 44, 28, 36, 20, 32, 42, 32, and 42}	
5	ECP18	0	Byte 18 Hamming error check on (data held) {Byte 43, 27, 35, 19, 31, 41, 31, and 41}	
		1	Byte 18 Hamming error check off (data written) {Byte 43, 27, 35, 19, 31, 41, 31, and 41}	
4	ECP17	0	Byte 17 Hamming error check on (data held) {Byte 42, 26, 34, 18, 30, 40, 30, and 40}	
		1	Byte 17 Hamming error check off (data written) {Byte 42, 26, 34, 18, 30, 40, 30, and 40}	
3	ECP16	0	Byte 16 Hamming error check on (data held) {Byte 41, 25, 33, 17, 29, 39, 29, and 39}	
		1	Byte 16 Hamming error check off (data written) {Byte 41, 25, 33, 17, 29, 39, 29, and 39}	
2	ECP15	0	Byte 15 Hamming error check on (data held) {Byte 40, 24, 32, 16, 28, 38, 28, and 38}	
		1	Byte 15 Hamming error check off (data written) {Byte 40, 24, 32, 16, 28, 38, 28, and 38}	
1	ECP14	0	Byte 14 Hamming error check on (data held) {Byte 39, 23, 31, 15, 27, 37, 27, and 37}	
		1	Byte 14 Hamming error check off (data written) {Byte 39, 23, 31, 15, 27, 37, 27, and 37}	
0	ECP13	0	Byte 13 Hamming error check on (data held) {Byte 38, 22, 30, 14, 26, 36, 26, and 36}	
		1	Byte 13 Hamming error check off (data written) {Byte 38, 22, 30, 14, 26, 36, 26, and 36}	

Note: All registers are set to 0 when the LC74794/M is reset by the RST pin.

COMMAND17 (VPS/PDC control setup command)

First byte

DA 0 to 7	Register	Contents		Notes
		State	Function	
7	—	1	Command 7 identification code Display control setup	
6	—	1		
5	—	1		
4	—	1		
3	—	1	Extended command A identification code	
2	—	0		
1	—	1		
0	—	0		

Second byte

DA 0 to 7	Register	Contents		Notes
		State	Function	
7	—	0	Second byte identification bit	
6	—	0		
5	ECP25	0	Byte 25 Hamming error check on (data held)	Settings when the PDC data (8/30/2) BMS = 0. Settings in parentheses apply when BMS = 1. The items in curly brackets are the bytes for which the odd parity check is turned off in header modes 1, 2, 3, and 4 and status modes 1, 2, 3, and 4, respectively.
		1	Byte 25 Hamming error check off (data written)	
4	ECP24	0	Byte 24 Hamming error check on (data held)	
		1	Byte 24 Hamming error check off (data written)	
3	ECP23	0	Byte 23 Hamming error check on (data held)	
		1	Byte 23 Hamming error check off (data written)	
2	ECP22	0	Byte 22 Hamming error check on (data held) {Byte ..., 35, 45, 35, and 45}	
		1	Byte 22 Hamming error check off (data written) {Byte ..., 35, 45, 35, and 45}	
1	ECP21	0	Byte 21 Hamming error check on (data held) {Byte ..., 34, 44, 34, and 44}	
		1	Byte 21 Hamming error check off (data written) {Byte ..., 34, 44, 34, and 44}	
0	ECP20	0	Byte 20 Hamming error check on (data held) {Byte 45, 29, 37, 21, 33, 43, 33, and 43}	
		1	Byte 20 Hamming error check off (data written) {Byte 45, 29, 37, 21, 33, 43, 33, and 43}	

Note: All registers are set to 0 when the LC74794/M is reset by the RST pin.

**PDC/VPS Output Data Formats**

Data is read out in order starting with bytes 1 and 7

Output data	PDC 8/30 mode		VPS mode	Header time mode 1 (3)	Header time mode 2 (4)
	Format1	Format2			
Data update bits *: The value is 0 when data is updated and 1 when not updated.					
Byte 1 Bit 7 6 5 4 3 2 1 0	byte 15 bit 0 1 2 3 4 5 6 7	byte 16 bit 0 1 2 3 byte 17 bit 0 1 2 3	byte 11 bit 0 1 2 3 4 5 6 7	byte 38 bit 0 (30) 1 2 3 4 5 6 7	byte 22 bit 0 (14) 1 2 3 4 5 6 7
Byte 2 Bit 7 6 5 4 3 2 1 0	byte 16 bit 0 1 2 3 4 5 6 7	byte 18 bit 0 1 2 3 byte 19 bit 0 1 2 3	byte 12 bit 0 1 2 3 4 5 6 7	byte 39 bit 0 (31) 1 2 3 4 5 6 7	byte 23 bit 0 (15) 1 2 3 4 5 6 7
Byte 3 Bit 7 6 5 4 3 2 1 0	byte 17 bit 0 1 2 3 4 5 6 7	byte 20 bit 0 1 2 3 byte 21 bit 0 1 2 3	byte 13 bit 0 1 2 3 4 5 6 7	byte 40 bit 0 (32) 1 2 3 4 5 6 7	byte 24 bit 0 (16) 1 2 3 4 5 6 7
Byte 4 Bit 7 6 5 4 3 2 1 0	byte 18 bit 0 1 2 3 4 5 6 7	byte 22 bit 0 1 2 3 byte 23 bit 0 1 2 3	byte 14 bit 0 1 2 3 4 5 6 7	byte 41 bit 0 (33) 1 2 3 4 5 6 7	byte 25 bit 0 (17) 1 2 3 4 5 6 7
Byte 5 Bit 7 6 5 4 3 2 1 0	byte 19 bit 0 1 2 3 4 5 6 7	byte 14 bit 0 1 2 3 byte 15 bit 0 1 2 3	byte 5 bit 0 1 2 3 4 5 6 7	byte 42 bit 0 (34) 1 2 3 4 5 6 7	byte 26 bit 0 (18) 1 2 3 4 5 6 7
Byte 6 Bit 7 6 5 4 3 2 1 0	byte 20 bit 0 1 2 3 4 5 6 7	byte 24 bit 0 1 2 3 byte 25 bit 0 1 2 3	byte 15 bit 0 1 2 3 4 5 6 7	byte 43 bit 0 (35) 1 2 3 4 5 6 7	byte 27 bit 0 (19) 1 2 3 4 5 6 7

Continued on next page.



LC74794, 74794M

Continued from preceding page.

Output data	PDC 8/30 mode		VPS mode	Header time mode 1 (3)	Header time mode 2 (4)
	Format1	Format2			
Byte 7 Bit 7 6 5 4 3 2 1 0	byte 21 bit 0 1 2 3 4 5 6 7	byte 13 bit 0 1 2 3 1 1 1 1	1 1 1 1 1 1 1 0	byte 44 bit 0 (36) 1 2 3 4 5 6 7	byte 28 bit 0 (20) 1 2 3 4 5 6 7
Byte 8 Bit 7 6 5 4 3 2 1 0	byte 13 bit 0 1 2 3 4 5 6 7	Error information 1 byte 16 17 18 19 20 21 22 23	Error information 1 byte 11 12 13 14 15 0 0	byte 45 bit 0 (37) 1 2 3 4 5 6 7	byte 29 bit 0 (21) 1 2 3 4 5 6 7
Byte 9 Bit 7 6 5 4 3 2 1 0	byte 14 bit 0 1 2 3 4 5 6 7	Error information 2 byte 14 15 24 25 13 0 0 0		Error information byte 38 (30) 39 (31) 40 (32) 41 (33) 42 (34) 43 (35) 44 (36) 45 (37)	Error information byte 22 (14) 23 (15) 24 (16) 25 (17) 26 (18) 27 (19) 28 (20) 29 (21)
Byte 10 Bit 7 6 5 4 3 2 1 0	byte 22 bit 0 1 2 3 4 5 6 7				
Byte 11 Bit 7 6 5 4 3 2 1 0	byte 23 bit 0 1 2 3 4 5 6 7				
Byte 12 Bit 7 6 5 4 3 2 1 0	byte 24 bit 0 1 2 3 4 5 6 7				
Byte 13 Bit 7 6 5 4 3 2 1 0	byte 25 bit 0 1 2 3 4 5 6 7				

Bits for which there is no data setting are 1.

LC74794, 74794M

Data is read out in order starting with bytes 1 and 7

1, 2 : 8/30/2 3, 4 : 8/30/1

Output data	Status display mode 1 (3)	Status display mode 2 (4)	Output data	Status display mode 1 (3)	Status display mode 2 (4)
Data update bits *: The value is 0 when data is updated.					
Byte 1 Bit 7	byte 26 bit 0	byte 36 bit 0	Byte 8 Bit 7	byte 33 bit 0	byte 43 bit 0
6	(26) 1	(36) 1	6	(33) 1	(43) 1
5	2	2	5	2	2
4	3	3	4	3	3
3	4	4	3	4	4
2	5	5	2	5	5
1	6	6	1	6	6
0	7	7	0	7	7
Byte 2 Bit 7	byte 27 bit 0	byte 37 bit 0	Byte 9 Bit 7	byte 34 bit 0	byte 44 bit 0
6	(27) 1	(37) 1	6	(34) 1	(44) 1
5	2	2	5	2	2
4	3	3	4	3	3
3	4	4	3	4	4
2	5	5	2	5	5
1	6	6	1	6	6
0	7	7	0	7	7
Byte 3 Bit 7	byte 28 bit 0	byte 38 bit 0	Byte 10 Bit 7	byte 35 bit 0	byte 45 bit 0
6	(28) 1	(38) 1	6	(35) 1	(45) 1
5	2	2	5	2	2
4	3	3	4	3	3
3	4	4	3	4	4
2	5	5	2	5	5
1	6	6	1	6	6
0	7	7	0	7	7
Byte 4 Bit 7	byte 29 bit 0	byte 39 bit 0	Byte 11 Bit 7	Error information 1	Error information 1
6	(29) 1	(39) 1	6	byte 26 (26) 27 (27)	byte 36 (36) 37 (37)
5	2	2	5	28 (28) 29 (29)	38 (38) 39 (39)
4	3	3	4	30 (30) 31 (31)	40 (40) 41 (41)
3	4	4	3	32 (32) 33 (33)	42 (42) 43 (43)
2	5	5	2		
1	6	6	1		
0	7	7	0		
Byte 5 Bit 7	byte 30 bit 0	byte 40 bit 0	Byte 12 Bit 7	Error information 2	Error information 2
6	(30) 1	(40) 1	6	byte 34 (34) 35 (35)	byte 44 (44) 45 (45)
5	2	2	5	0	0
4	3	3	4	0	0
3	4	4	3	0	0
2	5	5	2	0	0
1	6	6	1	0	0
0	7	7	0	0	0
Byte 6 Bit 7	byte 31 bit 0	byte 41 bit 0	Byte 13 Bit 7		
6	(31) 1	(41) 1	6		
5	2	2	5		
4	3	3	4		
3	4	4	3		
2	5	5	2		
1	6	6	1		
0	7	7	0		
Byte 7 Bit 7	byte 32 bit 0	byte 42 bit 0			
6	(32) 1	(42) 1			
5	2	2			
4	3	3			
3	4	4			
2	5	5			
1	6	6			
0	7	7			

Bits for which there is no data setting are 1.

**Display Screen Structure**

The display consists of 12 lines of 24 characters each.

Up to 288 characters can be displayed.

The number of characters that can be displayed is reduced from the normal total of 288 when enlarged characters are displayed.

Display memory addresses are specified as row (0 to b hexadecimal) and column (0 to 17 hexadecimal) addresses.

**Display Screen Structure (display memory addresses)**

**24 characters × 12 rows**

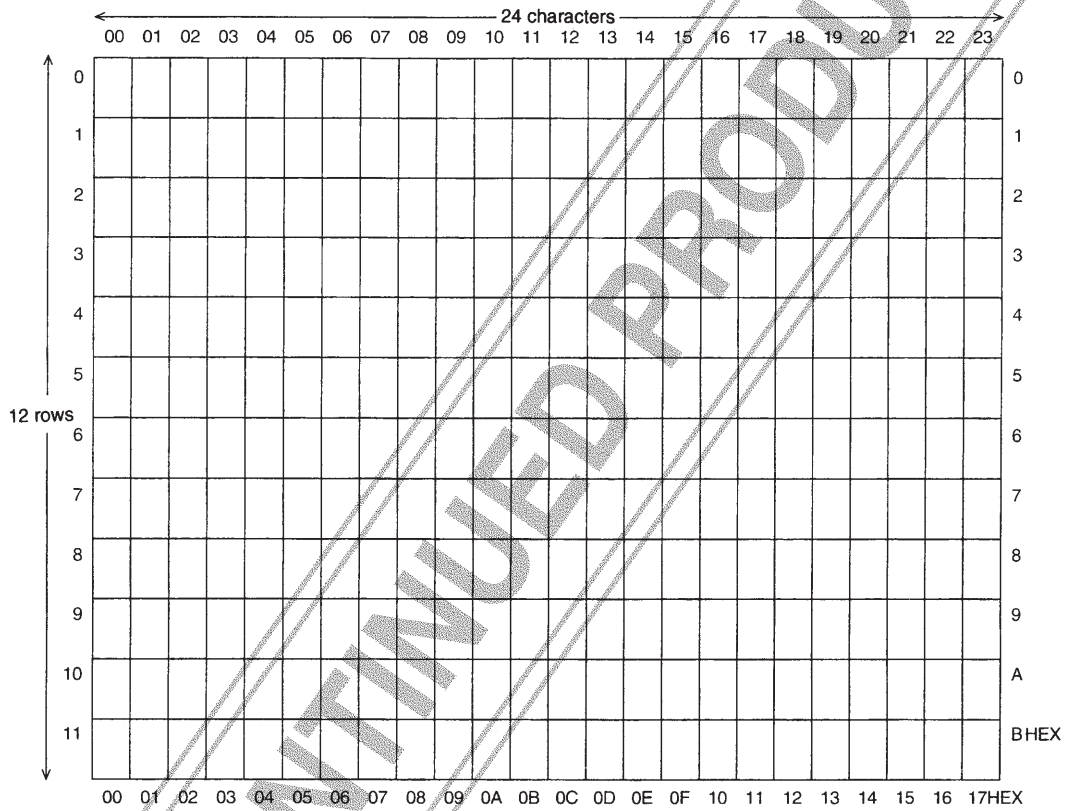

A06351

**Composite Video Signal Output Levels (internally generated levels)**

CV<sub>OUT</sub> output level waveform (V<sub>DD2</sub> = 5.0 V)

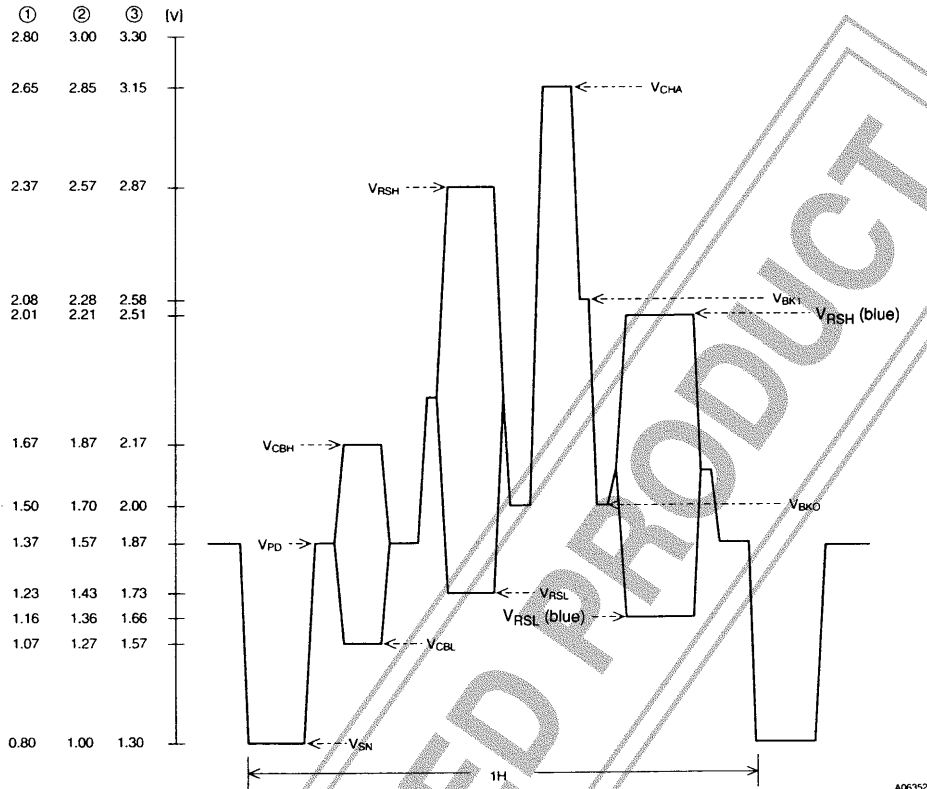

Output level	Output voltage (1) [V]	Output voltage (2) [V]	Output voltage (3) [V]
V <sub>CHA</sub> : Character	2.65	2.85	3.15
V <sub>RSH</sub> : Background color high	2.37 (2.01)	2.57 (2.21)	2.87 (2.51)
V <sub>CBH</sub> : Color burst high	1.67	1.87	2.17
V <sub>RSL</sub> : Background color low	1.23 (1.16)	1.43 (1.36)	1.73 (1.66)
V <sub>BK1</sub> : Border	2.08	2.28	2.58
V <sub>BK0</sub> : Border	1.50	1.70	2.00
V <sub>PD</sub> : Pedestal	1.37	1.57	1.87
V <sub>CBL</sub> : Color burst low	1.07	1.27	1.57
V <sub>SN</sub> : Sync	0.80	1.00	1.30

Note: V<sub>DD2</sub> = 5.0 V. Values in parentheses for V<sub>RSH</sub> and V<sub>RSL</sub> apply when the background color is blue.

- No products described or contained herein are intended for use in surgical implants, life-support systems, aerospace equipment, nuclear power control systems, vehicles, disaster/crime-prevention equipment and the like, the failure of which may directly or indirectly cause injury, death or property loss.
- Anyone purchasing any products described or contained herein for an above-mentioned use shall:
  - ① Accept full responsibility and indemnify and defend SANYO ELECTRIC CO., LTD., its affiliates, subsidiaries and distributors and all their officers and employees, jointly and severally, against any and all claims and litigation and all damages, cost and expenses associated with such use:
  - ② Not impose any responsibility for any fault or negligence which may be cited in any such claim or litigation on SANYO ELECTRIC CO., LTD., its affiliates, subsidiaries and distributors or any of their officers and employees jointly or severally.
- Information (including circuit diagrams and circuit parameters) herein is for example only; it is not guaranteed for volume production. SANYO believes information herein is accurate and reliable, but no guarantees are made or implied regarding its use or any infringements of intellectual property rights or other rights of third parties.

This catalog provides information as of February, 1997. Specifications and information herein are subject to change without notice.