



M.S.KENNEDY CORP.

HIGH LEVEL DIGITAL DRIVER

0006

4707 Dey Road Liverpool, N.Y. 13088

(315) 701-6751

MIL-PRF-38534 QUALIFIED

FEATURES:

- Single Supply Operation From 10V to 45V
- Replaces NH/DH0006
- 'And' Input Logic With Expander
- External Transition Time Control
- Output Current to 400mA
- Available to DSCC SMD 5962-87617

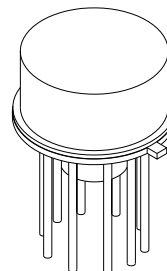

MSK0006

DESCRIPTION:

The MSK 0006 is an integrated high voltage, high current driver designed to accept standard DTL or TTL logic levels and drive a load of up to 400 mA at 28V. AND inputs are provided along with an Expander connection, should additional gating be required. The addition of an external capacitor provides control of the rise and fall times of the output. The device is packaged in a hermetic 10 pin can.

EQUIVALENT SCHEMATIC

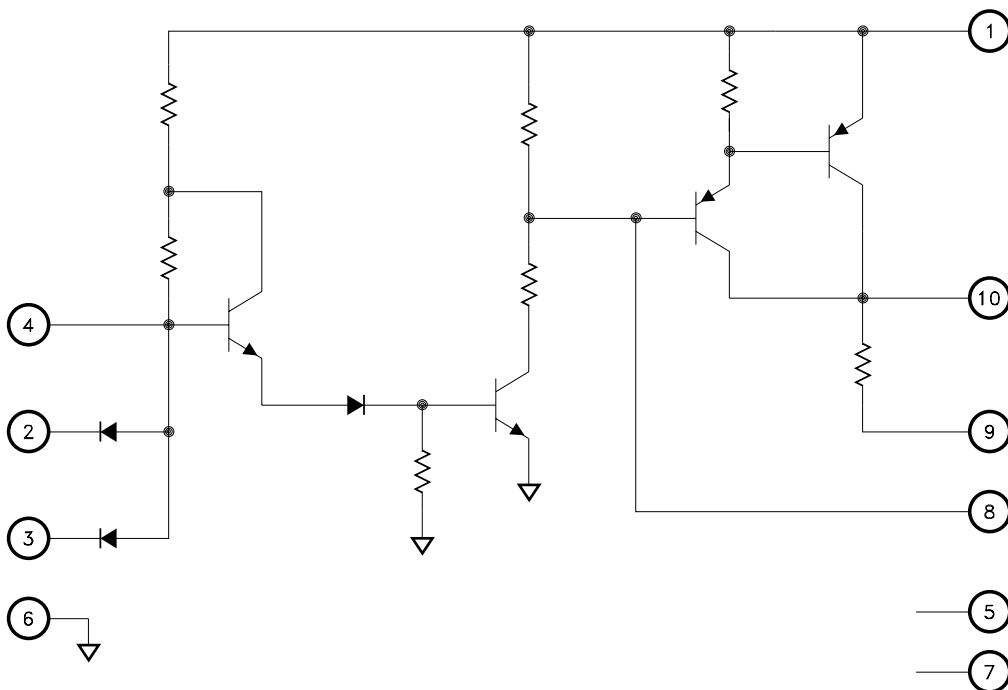

TYPICAL APPLICATIONS

- Logic Level Translator
- Relay Driver
- Lamp Driver

PIN-OUT INFORMATION

- | | |
|------------|---------------------------|
| 1 Vcc | 10 Output |
| 2 Input | 9 Response Time Control C |
| 3 Input | 8 Response Time Control B |
| 4 Expander | 7 NC |
| 5 NC | 6 Ground |

ABSOLUTE MAXIMUM RATINGS

V _{CC}	Supply Voltage (t ≤ 0.1 sec)	60V	T _{ST}	Storage Temperature Range	-65°C to +150°C
I _{OUT}	Output Current (50mS)	1.5A	T _{LD}	Lead Temperature Range	300°C
V _{IN}	Input Voltage	5.5V		(10 Seconds)	
I _{IN}	Expander Input Current	5mA	T _C	Case Operating Temperature	
				(MSK 0006H/E)	-55°C to +125°C
				(MSK 0006)	-40°C to +85°C
			T _J	Junction Temperature	175°C

ELECTRICAL SPECIFICATIONS

Parameter	Test Conditions ①	Group A Subgroup	MSK0006H/E			MSK0006			Units
			Min.	Typ.	Max.	Min.	Typ.	Max.	
Power Supply Range ②	Continuous	-	10	28	45	10	28	45	V
Logic 1 Input Voltage ②	10V ≤ V _{CC} ≤ 45V	1,2,3	2.0	-	5.5	2.0	-	5.5	V
Logic 0 Input Voltage ②	10V ≤ V _{CC} ≤ 45V	1,2,3	-	-	0.8	-	-	0.8	V
Logic 1 Output Voltage	V _{CC} = 28V V _{IN} = 2V R _L = 82Ω	1,2,3	26.5	27	-	26	27	-	V
	② V _{CC} = 10V V _{IN} = 2V I _O = 150mA	1,2,3	8.8	9	-	8.5	9	-	V
Logic 0 Output Voltage	V _{IN} = 0.8V R _L = 100Ω	1,2,3	-	5	10	-	5	15	mV
Logic 1 Input Current ②	V _{IN} = 2.4V	1,2,3	-	1	5	-	1	10	μA
	V _{IN} = 5.5V	1,2,3	-	25	100	-	25	150	μA
Logic 0 Input Current ②	V _{IN} = 0.4V	1,2,3	-1.0	-	-	-1.1	-	-	mA
Off Supply Current	V _{IN} = 0.8V	1,2,3	-	0.5	2.0	-	0.5	2.2	mA
On Supply Current	V _{IN} = 2.0V	1,2,3	-	6	8	-	6	8.5	mA
Rise Time	V _{CC} = 28V R _L = 82Ω	4,5,6	-	100	300	-	100	325	nS
Fall Time	V _{CC} = 28V R _L = 82Ω	4,5,6	-	0.8	1.7	-	0.8	1.8	μS
Turn On Time ②⑦	V _{CC} = 28V R _L = 82Ω	4,5,6	-	0.3	1.0	-	0.3	1.1	μS
Turn Off Time ②⑦	V _{CC} = 28V R _L = 82Ω	4,5,6	-	2.2	8.0	-	2.2	8.2	μS
Thermal Resistance ②	Junction to Case @ T _C = 125°C	-	-	60	68	-	60	70	°C/W

NOTES:

- ① V_{CC} = 45V, C_f = NC and I_{OUT} = 0mA unless otherwise specified.
- ② Guaranteed by design but not tested. Typical parameters are representative of actual device performance but are for reference only.
- ③ Industrial grade and "E" suffix devices shall be tested to subgroups 1 and 4 unless otherwise requested.
- ④ Military grade devices ("H" suffix) shall be 100% tested to subgroups 1,2,3 and 4.
- ⑤ Subgroup 5 and 6 testing available upon request.
- ⑥ Subgroup 1,4 T_C = +25°C
Subgroup 2,5 T_C = +125°C
Subgroup 3,6 T_A = -55°C
- ⑦ Measured from 50% of V_{IN} to 90% of V_{OUT} transition.

APPLICATION NOTES

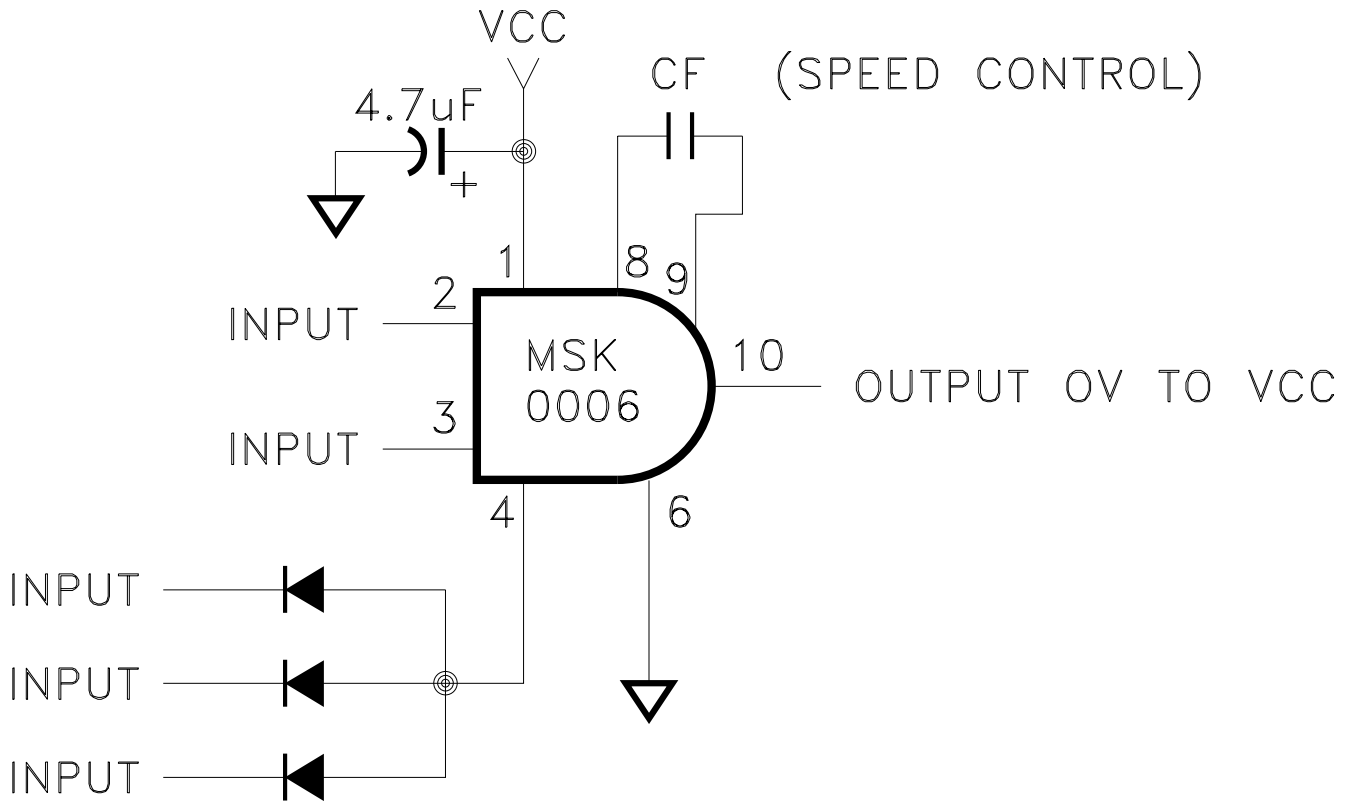

APPLICATION DIAGRAM

TYPICAL PERFORMANCE CURVES

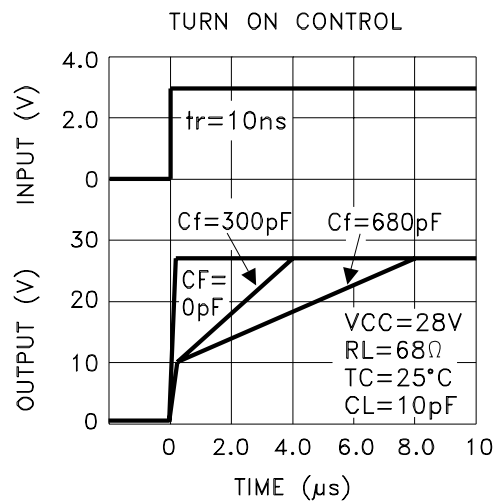
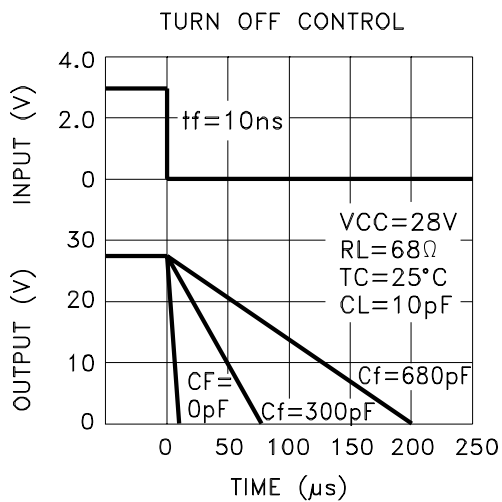
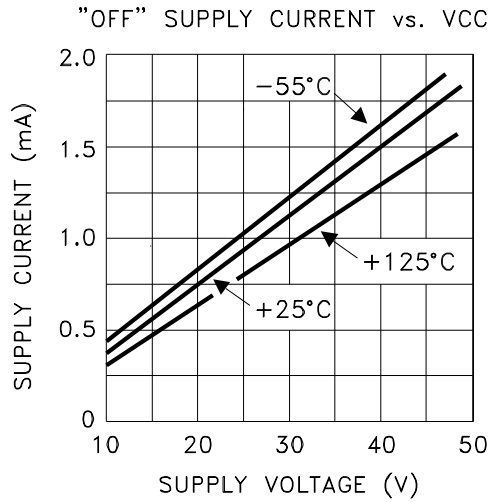
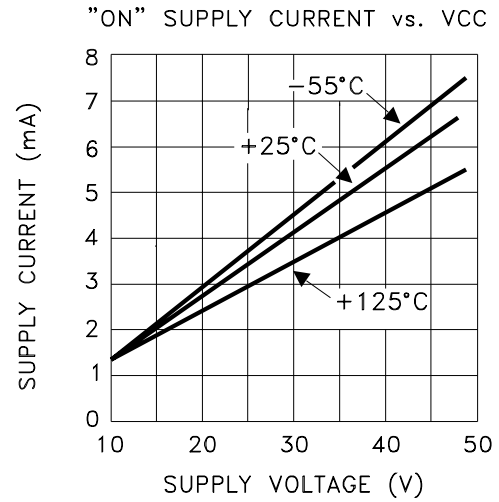
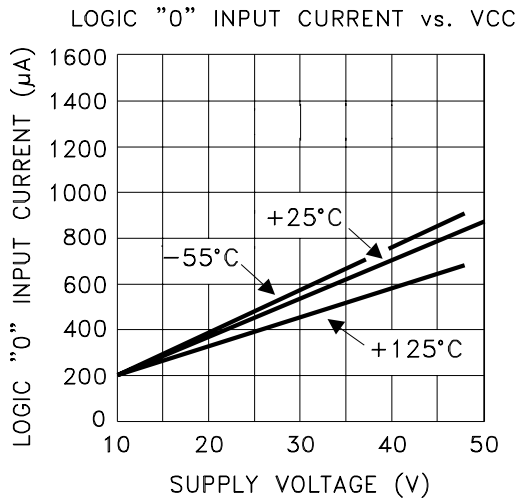

MECHANICAL SPECIFICATIONS

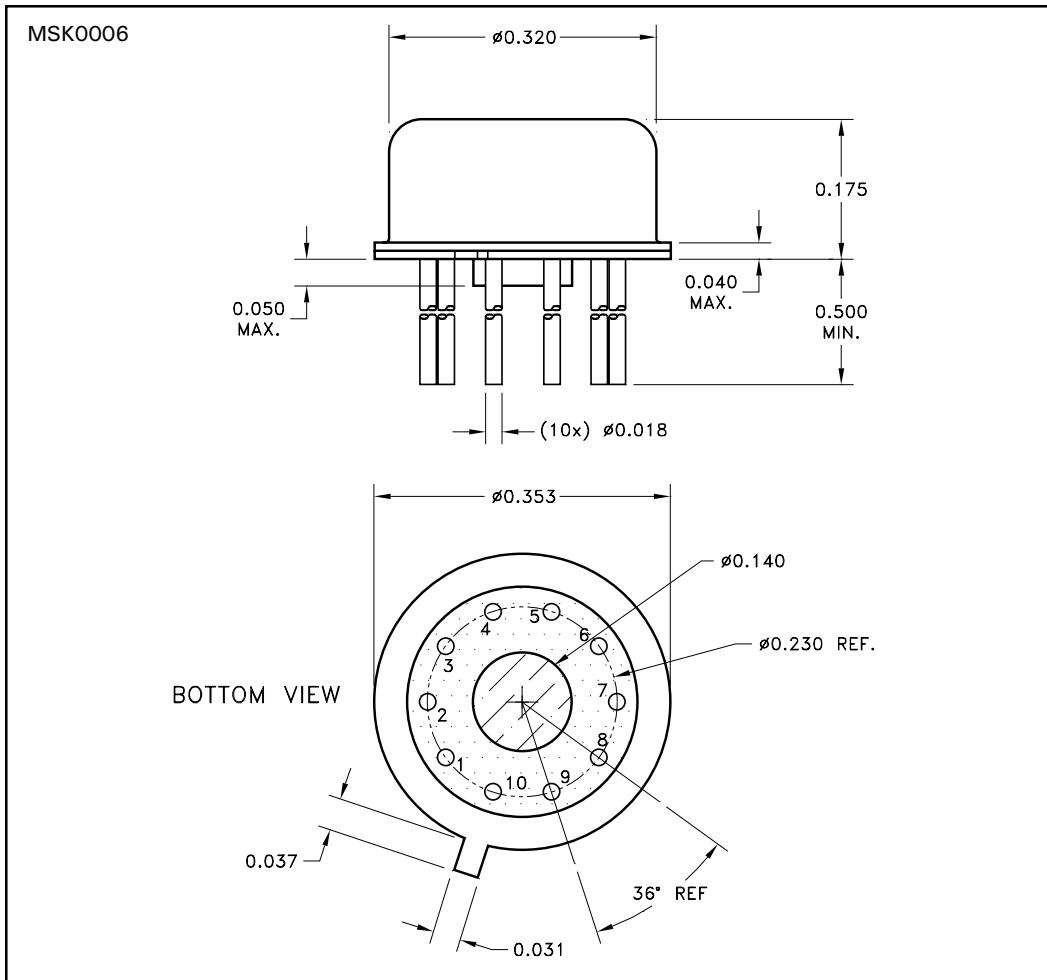

ORDERING INFORMATION

Part Number	Screening Level
MSK0006	Industrial
MSK0006E	Extended Reliability
MSK0006H	Mil-PRF-38534 Class H
5962-8761701X	DSCC-SMD

M.S. Kennedy Corp.
 4707 Dey Road, Liverpool, New York 13088
 Phone (315) 701-6751
 FAX (315) 701-6752
 www.mskennedy.com

The information contained herein is believed to be accurate at the time of printing. MSK reserves the right to make changes to its products or specifications without notice, however, and assumes no liability for the use of its products. Please visit our website for the most recent revision of this datasheet.