

FEATURES

- 3% Dynamic EVM @ P_{OUT} = +17 dBm with IEEE 802.11a 64 QAM OFDM at 54 Mbps
- 3% Dynamic EVM @ P_{OUT} = +20 dBm with IEEE 802.11g 64 QAM OFDM at 54 Mbps
- -30 dBc 1st Sidelobe / -50 dBc 2nd Sidelobe at +22.5 dBm w/ IEEE 802.11b, 1 Mbps CCK/ DSSS
- 31 dB of Linear Power Gain in 2 GHz and 5 GHz Transmit Paths
- 2.6 dB Noise Figure in 2 GHz Receive Path and 2.5 dB in 5 GHz Receive Path
- Single +3.3 V Nominal Supply
- SP3T RF Switch w/Bluetooth and 2 GHz Tx/Rx
- SP2T RF Switch for 5 GHz Tx/Rx Function
- Independent Switch Control for BT, 2 GHz, and 5 GHz Tx/Rx Paths
- 12 dB Gain in 2 GHz Receive Path and 14 dB in 5 GHz Receive Path
- LNA Bypass Mode in 2 GHz and 5 GHz Receive Paths
- 50 Ω - Matched RF Ports
- Leadfree Package
- Materials set consistent with RoHS Directive
- 4.0 x 4.0 x 0.55 mm QFN Package

APPLICATIONS

- 802.11a/b/g/n WLAN for Fixed, Mobile, and Handheld applications

PRODUCT DESCRIPTION

The ANADIGICS AWL9966 is a high performance FEIC that incorporates dual band power amplifiers, low-noise amplifiers, RF switches, and filters. The FEIC is designed for WLAN transmit and receive applications in the 2.412-2.484 GHz and 5.15-5.85 GHz bands. Matched to 50 Ohms at all RF inputs and outputs, the part requires no additional RF matching components off-chip. The antenna ports are switched between WLAN transmit, WLAN receive, Bluetooth, and simultaneous WLAN and Bluetooth paths with low loss RF switches. The PAs exhibit unparalleled linearity

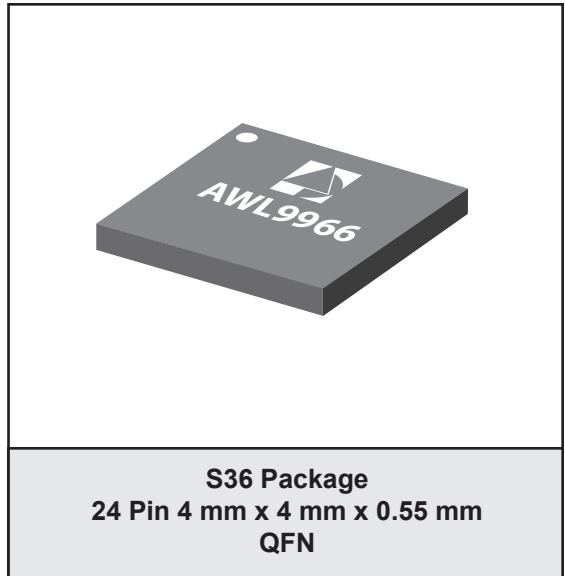

and efficiency for IEEE 802.11g, 802.11b, 802.11a and 802.11n WLAN systems under the toughest signal configurations within these standards.

A single temperature-compensated power detector is used in the FEIC to serve both WLAN bands. The detector provides a single-ended output voltage with excellent accuracy over a wide range of operating temperatures. All circuits are biased by a single +3.3V supply and consume ultra-low current in the OFF mode.

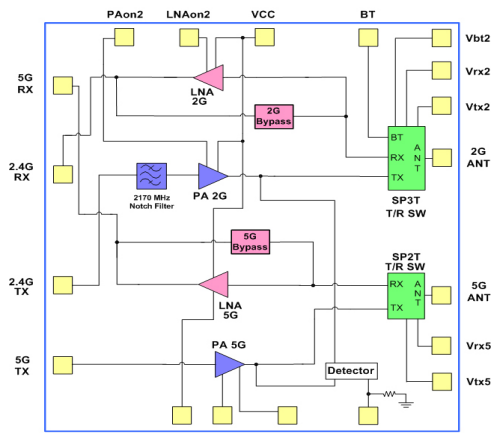

Figure 1: Block Diagram and Pinout

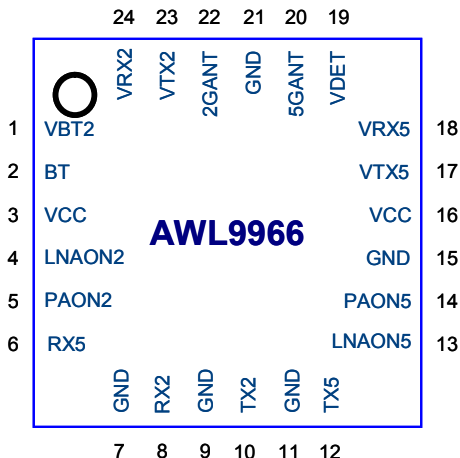

Figure 2: Pinout Diagram

Table 1: Pin Description

PIN	NAME	DESCRIPTION	PIN	NAME	DESCRIPTION
1	VBT2	Bluetooth enable. On/Off control for the Bluetooth RF path.	13	LNAON5	5 GHz LNA Enable. On/Off control for the 5 GHz receive path low noise amplifier.
2	BT	Bluetooth RF port.	14	PAON5	5 GHz PA Enable. On/Off control for the 5 GHz transmit path power amplifier.
3	VCC	Power Supply. Bias for transistors.	15	GND	Ground.
4	LNAON2	2 GHz LNA Enable. On/Off control for the 2 GHz receive path low noise amplifier.	16	VCC	Power Supply. Bias for transistors.
5	PAON2	2 GHz PA Enable. On/Off control for the 2 GHz transmit path power amplifier.	17	VTX5	Switch control for 5 GHz transmit path.
6	RX5	5 GHz RF receive output port.	18	VRX5	Switch control for 5 GHz receive path.
7	GND	Ground.	19	VDET	Power Detector Output. DC coupled power detector output
8	RX2	2 GHz RF receive output port.	20	5GANT	5 GHz Antenna Port.
9	GND	Ground.	21	GND	Ground.
10	TX2	2 GHz RF transmit input port.	22	2GANT	2 GHz Antenna Port.
11	GND	Ground.	23	VTX2	Switch control for 2 GHz transmit path.
12	TX5	5 GHz RF transmit input port.	24	VRX2	Switch control for 2 GHz receive path.

ELECTRICAL CHARACTERISTICS

Table 2: Absolute Minimum and Maximum Ratings
Operating Conditions: T_c=+25 °C, V_{cc}=+3.3 V, V_{controls}=+3.3 V

PARAMETER	MIN	MAX	UNIT	COMMENTS
DC Power Supply Voltages (VCC)	-	+6.0	V	
RF Input Level, 2.4 GHz PA, 5 GHz PA	-	+5	dBm	Modulated
Ambient Temperature	-40	+85	C	
Storage Temperature	-55	+85	C	
Storage Humidity	-	60	%	
ESD Tolerance	400 25	- -	V	Human Body Model (HBM), all pins Machine Model (MM), all pins
MSL Rating	-	MSL-2	-	

Notes:

1. Stresses in excess of the absolute ratings may cause permanent damage. Functional operation is not implied under these conditions. Exposure to absolute ratings for extended periods of time may adversely affect reliability.

Table 3: Operating Ranges

PARAMETER	MIN	TYP	MAX	UNIT	COMMENTS
Operating Frequency Ranges	2412 5150	- -	2484 5850	MHz	802.11b/g 802.11a
DC Power Supply Voltage (V _{cc})	+3.0	+3.3	+3.6	V	With RF applied
Control Pin Voltage (PA _{ON} 2, LNA _{ON} 2, PA _{ON} 5, LNA _{ON} 5, V _{BT} 2, V _{RX} 2, V _{TX} 2, V _{RX} 5, V _{TX} 5)	+2.8 0	+3.3 0	+3.6 +0.5	V	Logic High/On Logic Low/Off
Ambient Temperature	-40	-	+85	°C	

Notes:

The device may be operated safely over these conditions; however, parametric performance is guaranteed only over the conditions defined in the electrical specifications.

Table 4: Electrical Specifications - 802.11b/g Transmit Path
 (T_c = +25 °C, V_{CC} = +3.3 V, P_{AON2} = +3.3 V, V_{TX2} = +3.3 V, V_{RX2} = V_{BT2} = 0 V)
 Static Mode 64 QAM OFDM 54 Mbps

PARAMETER	MIN	TYP	MAX	UNIT	COMMENTS
Operating Frequency	2412	-	2484	MHz	
Power Gain	27	31	36	dB	
Gain Flatness	-	+/-1.0 +/-0.5	-	dB	Across full band Across any 40 MHz band
Error Vector Magnitude (EVM) ⁽¹⁾	-	-30	-	dB	P _{OUT} = 20 dBm, Dyn Mode, 54 Mbps
	-	190	-	mA	Avg current during packet
	-	-33	-28.5	dB	P _{OUT} = 18 dBm, Dyn Mode, 54 Mbps
	-	175	195	mA	Avg current during packet
	-	-36	-	dB	P _{OUT} = 16 dBm, Dyn Mode, 54 Mbps
	-	140	-	mA	Avg current during packet
	-	-40	-	dB	P _{OUT} = 5 dBm, Dyn Mode, 54 Mbps
	-	95	-	mA	Avg current during packet
ACPR Sidelobe 1	21	22.6	-	dBm	ACPR1 = -30 dBc, CCK 1 Mbps, root cosine filtering $\alpha = 0.45$
ACPR Sidelobe 2	21	22.6	-	dBm	ACPR2 = -50 dBc, CCK 1 Mbps, root cosine filtering $\alpha = 0.45$
Transmit Mask	Pass	-	-	dBm	P _{OUT} = 22.5 dBm CCK all rates P _{OUT} = 20 dBm OFDM all rates,
PA Noise Figure	-	5	-	dB	
PA Out of Band Noise Power	-	-150	-	dBm/Hz	WCDMA RX Band (2.11 to 2.17 GHz)
PsAT	-	26	-	dBm	
Group Delay	-	2.5	-	nS	
Group Delay Variation	-	0.5	-	nS	For any 20 MHz channel
Return Loss, Input	12	17	-	dB	50 Ω
Return Loss, Output	6	10	-	dB	50 Ω
TX Output Spurious Levels 2 fo 3 fo 4 fo	-	-29 -48 -55	-	dBm/MHz	For power levels up to 23 dBm, CCK at 1 Mbps
TX Output Spurious Levels Non-Harmonics	-	-60	-	dBm/MHz	For power levels up to 23 dBm, CCK at 1 Mbps
Stability and Load Mismatch Susceptibility	-	-60	-	dBc	Unconditionally stable and no damage, 5:1 VSWR, up to P _{OUT} = 20 dBm, OFDM at 54 Mbps
Settling Time	-	0.5	1.0	μ s	Within 1.0 dB of final value
Quiescent Current	-	95	115	mA	
Shutdown Current	-	12	25	μ A	V _{CC} = 3.3 V, all other controls = 0 V

Note:

(1) EVM includes system noise floor of 1% (-40 dB).

Table 5: Electrical Specification - 2 GHz Receive Path - LNA Mode
 (T_c = +25 °C, V_{CC} = +3.3 V, LNA_{ON2} = +3.3 V, V_{RX2} = +3.3 V, V_{TX2} = V_{BT2} = 0 V)

PARAMETER	MIN	TYP	MAX	UNIT	COMMENTS
Operating Frequency	2412	-	2484	MHz	
Power Gain	10	12	14	dB	
Gain Flatness	-	+/-0.5 +/-0.25	-	dB	Across full band Across any 40 MHz band
Noise Figure	-	2.6	3.9	dB	
Reverse Isolation	-	17	-	dB	
Group Delay	-	1.0	-	nS	
Group Delay Variation	-	0.5	-	nS	For any 20 MHz channel
Input Return Loss	-	4	-	dB	50 Ω
Output Return Loss	-	7	-	dB	50 Ω
IIP3	-	-1	-	dBm	
IP1dB	-	-10	-	dBm	
Settling Time	-	0.5	1.0	μs	Within 1.0 dB of final value
I _{CC} Quiescent Current	-	10	14	mA	

Table 6: Electrical Specification - 2 GHz Receive Path - Bypass Mode
 (T_c = +25 °C, V_{CC} = +3.3 V, LNA_{ON2} = 0 V, V_{RX2} = +3.3 V, V_{TX2} = V_{BT2} = 0 V)

PARAMETER	MIN	TYP	MAX	UNIT	COMMENTS
Operating Frequency	2412	-	2484	MHz	
Insertion Loss	-	3.5	4.5	dB	
Gain Flatness	- -	+/-0.5 +/-0.25	- -	dB	Across full band Across any 40 MHz band
Input Return Loss	-	7	-	dB	50 Ω
Output Return Loss	-	6	-	dB	50 Ω
IIP3	-	27	-	dBm	
IP1dB	-	24	-	dBm	
Settling Time	-	0.5	1.0	μs	Within 1.0 dB of final value
Quiescent Current	-	12	25	μA	

Table 7: Electrical Specification - Bluetooth TX/RX
 (T_c = +25 °C, V_{CC} = 0 V, LNA_{ON2} = 0 V, V_{RX2} = 0 V, V_{BT2} = +3.3 V, V_{TX2} = 0 V)

PARAMETER	MIN	TYP	MAX	UNIT	COMMENTS
Operating Frequency	2402	-	2480	MHz	
Insertion Loss	-	1.4	2.5	dB	
Gain Flatness	-	+/-0.25	-	dB	Across any 40 MHz band
Input Return Loss	-	10	-	dB	50 Ω
Output Return Loss	-	10	-	dB	50 Ω
BT - RX Isolation	-	20	-	dB	
BT - TX Isolation	-	40	-	dB	
Settling Time	-	0.5	1.0	μs	Within 1.0 dB of final value
Quiescent Current	-	12	25	μA	

Table 8: Electrical Specification - 802.11a Transmit Path
 (T_c = +25 °C, V_{CC} = +3.3 V, PA_{ON5} = +3.3 V, V_{TX5} = +3.3 V, V_{RX5} = 0 V,
 Static Mode 64 QAM OFDM 54 Mbps)

PARAMETER	MIN	TYP	MAX	UNIT	COMMENTS
Operating Frequency	5150	-	5850	MHz	
Power Gain	27	31	36	dB	
Gain Flatness	- -	+/-2.0 +/-0.5	- -	dB	Across full band Across any 40 MHz band
Error Vector Magnitude (EVM) ⁽¹⁾	- -	-30 160	-28 185	dB mA	P _{OUT} = 17 dBm, Dyn Mode, 54 Mbps Avg current during packet
	- -	-33 130	- -	dB mA	P _{OUT} = 15 dBm, Dyn Mode, 54 Mbps Avg current during packet
	- -	-40 90	- -	dB mA	P _{OUT} = 5 dBm, Dyn Mode, 54 Mbps Avg current during packet
Transmit Mask	Pass	-	-	N/A	OFDM, All rates, P _{OUT} = 18 dBm
PA Noise Figure	-	6	-	dB	
Group Delay	-	1.5	-	nS	
Group Delay Variation	-	0.5	-	nS	For any 20 MHz channel
Input Return Loss	7	11	-	dB	
Output Return Loss	10	14	-	dB	
TX Output Spurious Levels 2 fo 3 fo 4 fo	- - -	-26 -42 -60	- - -	dBm/ MHz	For power levels up to 18 dBm, OFDM 54 Mbps
TX Output Spurious Levels Non-Harmonics	-	-52	-	dBm/ MHz	For power levels up to 18 dBm, OFDM 54 Mbps
Stability and Load Mismatch Susceptibility	-	-60	-	dBc	Unconditionally stable and no damage, 5:1 VSWR, up to P _{OUT} = 18 dBm, OFDM @ 54 Mbps
Settling Time		0.8	2.0	μs	Within 1.0 dB of final value
Quiescent Current	-	95	115	mA	
Shutdown Current	-	12	25	μA	V _{CC} = 3.3 V, all other controls = 0 V

Note:

(1) EVM includes system noise floor of 1% (-40 dB).

Table 9: Electrical Specification - 5 GHz Receive Path - LNA Mode
 (T_c = +25 °C, V_{cc} = +3.3 V, LNA_{ON5} = +3.3 V, V_{Rx5} = +3.3 V, V_{Tx5} = 0 V)

PARAMETER	MIN	TYP	MAX	UNIT	COMMENTS
Operating Frequency	5150	-	5850	MHz	
Power Gain	10	14	18	dB	
Gain Flatness	- -	+/-1.0 +/-0.25	- -	dB	Across full band Across any 40 MHz band
Noise Figure	-	2.5	3.9	dB	
Reverse Isolation	-	21	-	dB	
Group Delay	-	1.5	-	nS	
Group Delay Variation	-	0.5	-	nS	For any 20 MHz channel
Input Return Loss	-	4	-	dB	50 Ω
Output Return Loss	-	6	-	dB	50 Ω
IIP3	-	-12	-	dBm	
IP1dB	-	-18	-	dBm	
Settling Time	-	0.5	1.0	μs	Within 1.0 dB of final value
Quiescent Current	-	12	16	mA	

Table 10: Electrical Specification - 5 GHz Receive Path - Bypass Mode
 (T_C = +25 °C, V_{CC} = +3.3 V, LNA_{ON5} = 0 V, V_{RX5} = +3.3 V, V_{TX5} = 0 V)

PARAMETER	MIN	TYP	MAX	UNIT	COMMENTS
Operating Frequency	5150		5850	MHz	
Insertion Loss	-	5.25	6.5	dB	
Gain Flatness	- -	+/-1.0 +/-0.25	- -	dB	Across full band Across any 40 MHz band
Input Return Loss	-	13	-	dB	50 Ω
Output Return Loss	-	10	-	dB	50 Ω
IIP3	-	30	-	dBm	
IP1dB	-	20	-	dBm	
Settling Time	-	0.5	1.0	μs	Within 1.0 dB of final value
Quiescent Current	-	12	25	μA	

Table 11: Electrical Specification - Power Detector
 (T_C = +25 °C, V_{CC} = +3.3 V, PA_{ON2/5} = +3.3 V, V_{TX2/5} = +3.3 V)

PARAMETER	MIN	TYP	MAX	UNIT	COMMENTS
Voltage Range	200	-	800	mV	+1 dBm ≤ P _{OUT} ≤ +21 dBm CW, 2 GHz and 5 GHz
Total Internal Load Impedance	-	5	-	kΩ	
Dynamic Range	-	20	-	dB	
Resolution	-	15	-	mV/dB	P _{OUT} > +7 dBm
Video Bandwidth	-	15	-	MHz	Adjustable with external RC Load

Table 12: Electrical Specification - Switch and Control Lines
 (T_c = +25 °C, V_{cc} = +3.3 V, V_{control pins High} = +3.3 V, V_{control pins Low} = 0 V)

PARAMETER	MIN	TYP	MAX	UNIT	COMMENTS
Control Pin Steady State Input Current (PA _{ON2} , LNA _{ON2} , PA _{ON5} , LNA _{ON5})	- -	200 0.5	- -	μA	Logic High/On Logic Low/Off
Control Pin Steady State Input Current (V _{BT2} , V _{RX2} , V _{TX2} , V _{RX5} , V _{TX5})	- -	5 0.5	- -	μA	Logic High/On Logic Low/Off
Control Pin Input Impedance	-	16.5	-	kΩ	Logic High/On
TX2 - RX2 Isolation	-	30	-	dB	
TX5 - RX5 Isolation	-	25	-	dB	

**PERFORMANCE DATA PLOTS:
2 GHz Tx Performance**

Figure 3: Tx Path Gain vs. Output Power Across Frequency ($V_{CC} = +3.3\text{ V}$, $T_C = +25\text{ }^\circ\text{C}$, 802.11g, 54 Mbps OFDM)

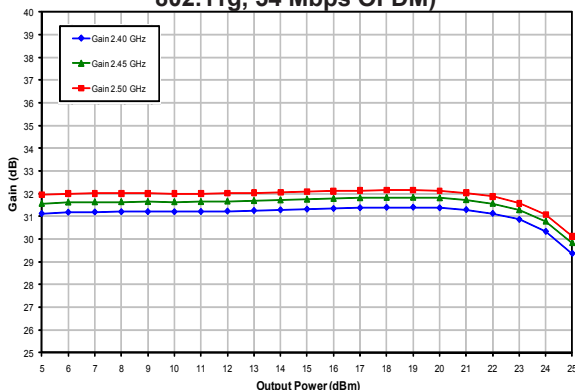

Figure 4: Tx Path Gain vs. Output Power Across Voltage (Freq = 2.45 GHz, $T_C = +25\text{ }^\circ\text{C}$, 802.11g, 54 Mbps OFDM)

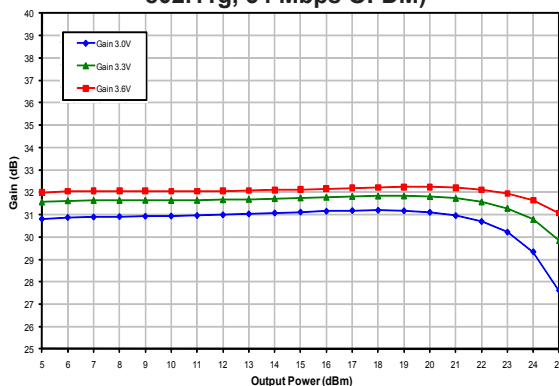

Figure 5: Tx Path Gain vs. Output Power Across Temperature (Freq = 2.45 GHz, $V_{CC} = +3.3\text{ V}$, 802.11g, 54 Mbps OFDM)

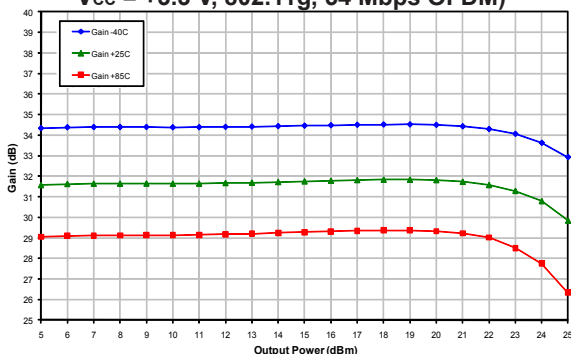

Figure 6: Tx Path Icc vs. Output Power Across Frequency ($V_{CC} = +3.3\text{ V}$, $T_C = +25\text{ }^\circ\text{C}$, 802.11g, 54 Mbps OFDM)

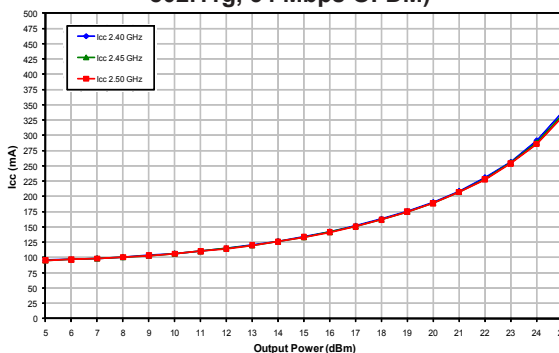

Figure 7: Tx Path Icc vs. Output Power Across Voltage (Freq = 2.45 GHz, $T_C = +25\text{ }^\circ\text{C}$, 802.11g, 54 Mbps OFDM)

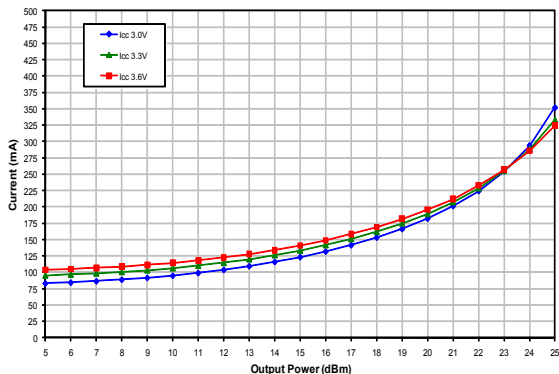

Figure 8: Tx Path Icc vs. Output Power Across Temperature (Freq = 2.45 GHz, $V_{CC} = +3.3\text{ V}$, 802.11g, 54 Mbps OFDM)

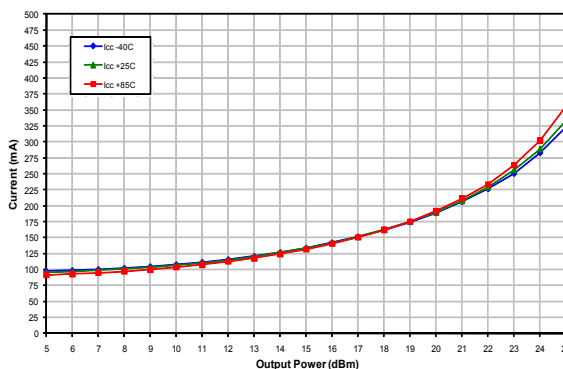

Figure 9: Tx Path Dynamic EVM vs. Output Power Across Frequency ($V_{CC} = +3.3\text{ V}$, $T_c = +25\text{ }^\circ\text{C}$, 802.11g, 54 Mbps OFDM)

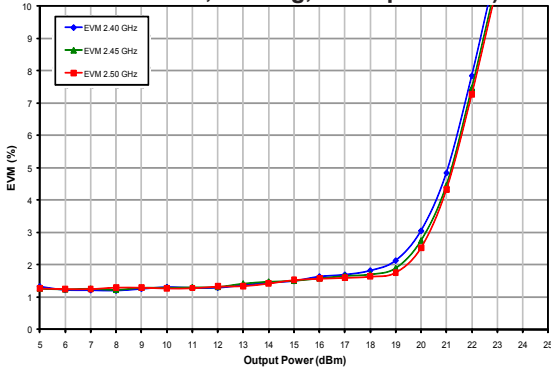

Figure 10: Tx Path Dynamic EVM vs. Output Power Across Voltage (Freq = 2.45 GHz, $T_c = +25\text{ }^\circ\text{C}$, 802.11g, 54 Mbps OFDM)

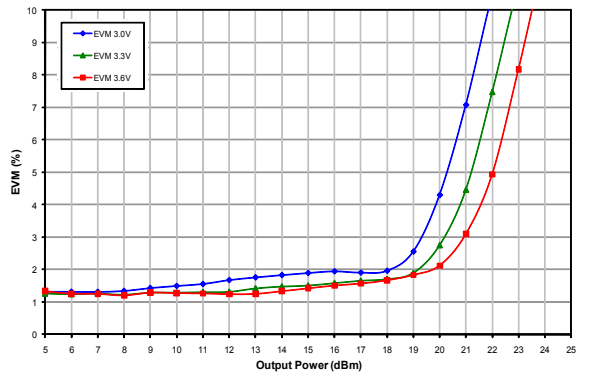

Figure 11: Tx Path Dynamic EVM vs. Output Power Across Temperature (Freq = 2.45 GHz, $V_{CC} = +3.3\text{ V}$, 802.11g, 54 Mbps OFDM)

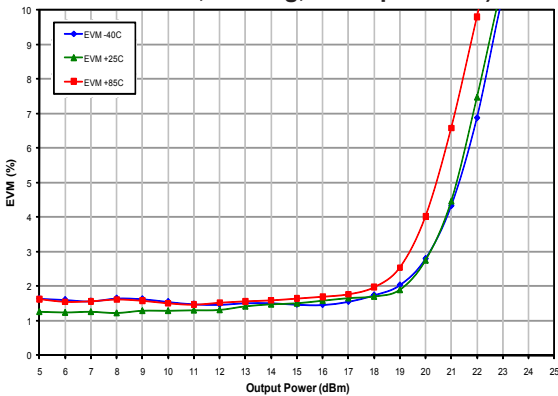

Figure 12: 2 GHz Tx Path S21 Response ($T_c = +25\text{ }^\circ\text{C}$ $V_{CC} = +3.3\text{ V}$)

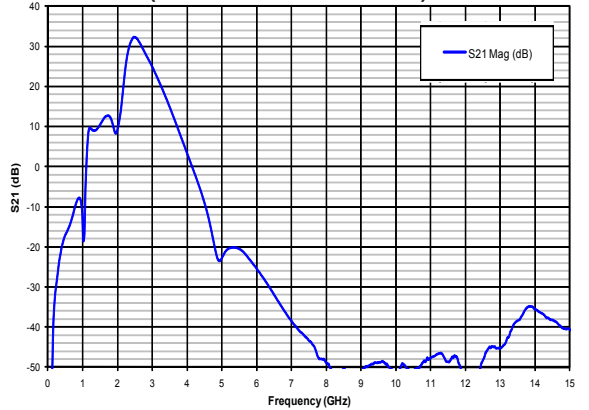
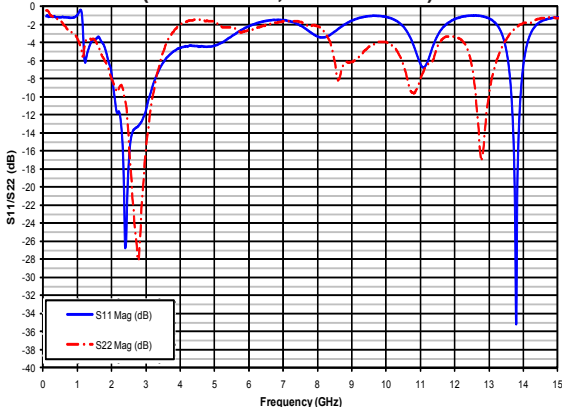

Figure 13: 2 GHz Tx Path S11 & S22 Return Loss ($T_c = +25\text{ }^\circ\text{C}$, $V_{CC} = +3.3\text{ V}$)



5 GHz Tx Performance

Figure 14: Tx Path Gain vs. Output Power Across Frequency ($T_c = +25\text{ }^\circ\text{C}$, $V_{CC} = +3.3\text{ V}$, 802.11a, 54 Mbps OFDM)

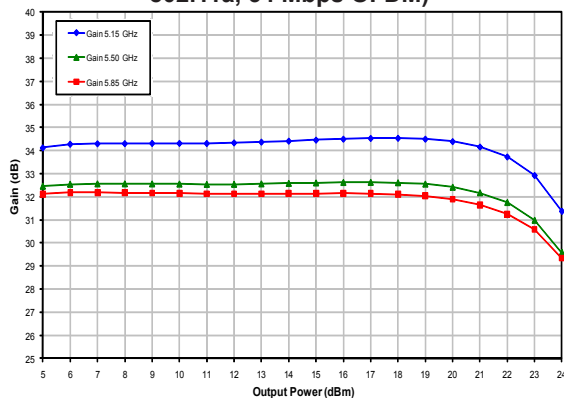

Figure 15: Tx Path Gain vs. Output Power Across Voltage ($T_c = +25\text{ }^\circ\text{C}$, Freq = 5.5 GHz, 802.11a, 54 Mbps OFDM)

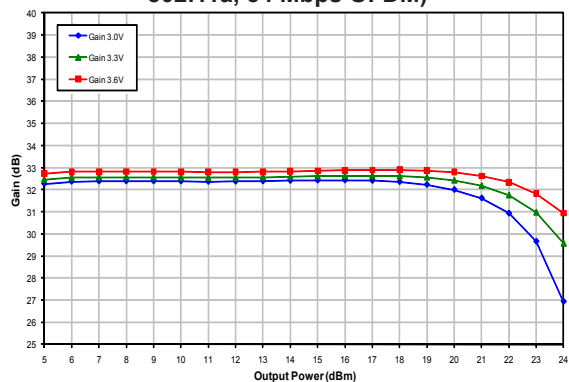

Figure 16: Tx Path Gain vs. Output Power Across Temperature (Freq = 5.5 GHz, $V_{CC} = +3.3\text{ V}$, 802.11a, 54 Mbps OFDM)

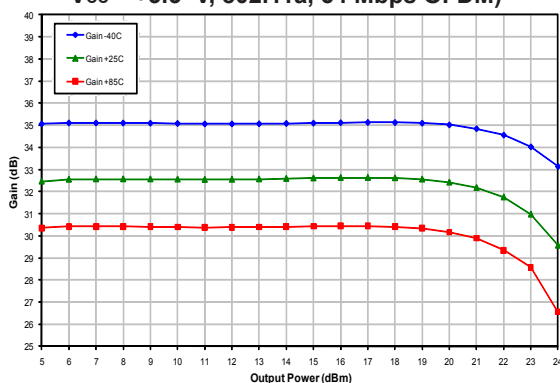

Figure 17: Tx Path ICC vs. Output Power Across Frequency ($T_C = +25\text{ }^\circ\text{C}$, $V_{CC} = +3.3\text{ V}$, 802.11a, 54 Mbps OFDM)

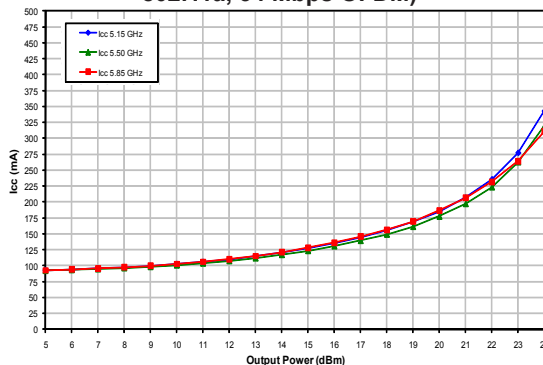

Figure 18: Tx Path ICC vs. Output Power Across Voltage ($T_c = +25\text{ }^\circ\text{C}$, Freq = 5.5 GHz, 802.11a, 54 Mbps OFDM)

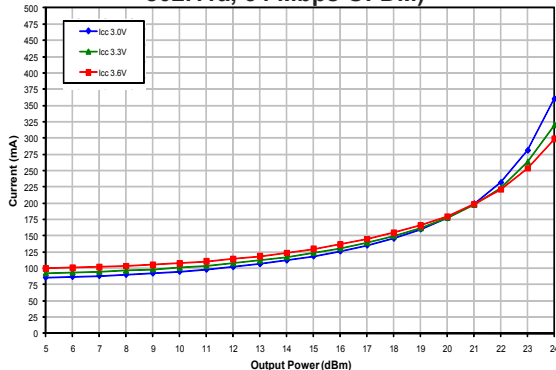

Figure 19: Tx Path ICC vs. Output Power Across Temperature (Freq = 5.5 GHz, $V_{CC} = +3.3\text{ V}$, 802.11a, 54 Mbps OFDM)

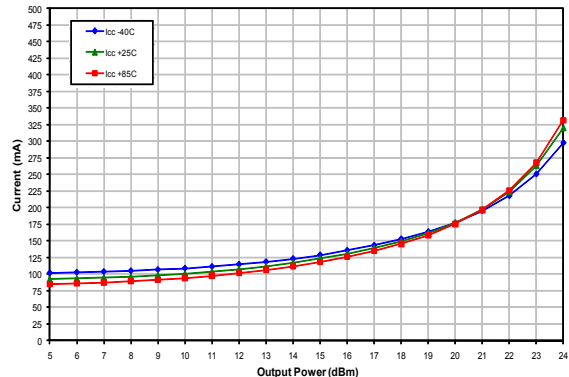

Figure 20: Tx Path Dynamic EVM vs. Output Power Across Frequency (T_c = +25 °C, V_{cc} = +3.3 V, 802.11a, 54 Mbps OFDM)

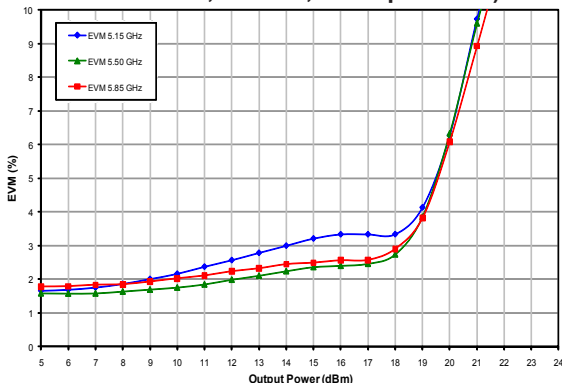

Figure 21: Tx Path Dynamic EVM vs. Output Power Across Voltage (T_c = +25 °C, Freq = 5.5 GHz, 802.11a, 54 Mbps OFDM)

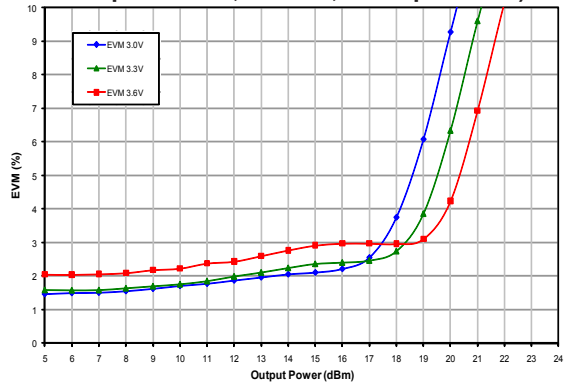

Figure 22: Tx Path Dynamic EVM vs. Output Power Across Temperature (Freq = 5.5 GHz, V_{cc} = +3.3 V, 802.11a, 54 Mbps OFDM)

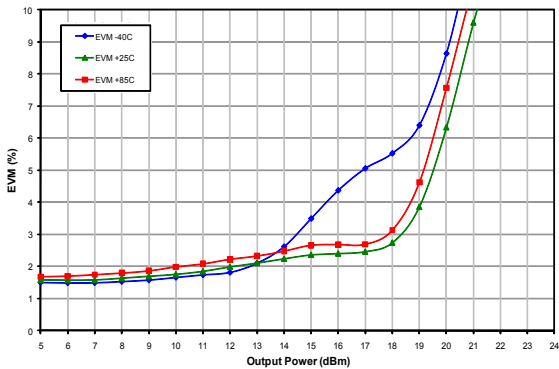

Figure 23: 5 GHz Tx Path S₂₁ Response (T_c = +25 °C, V_{cc} = +3.3 V)

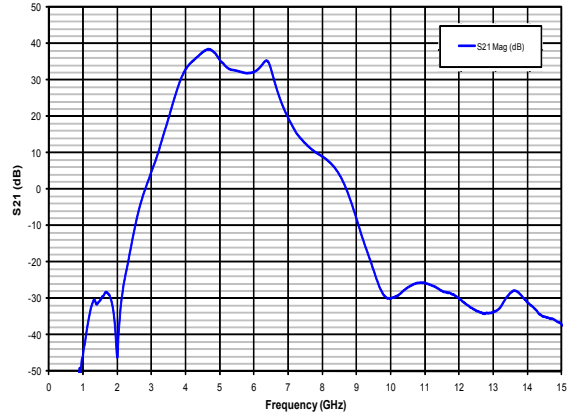
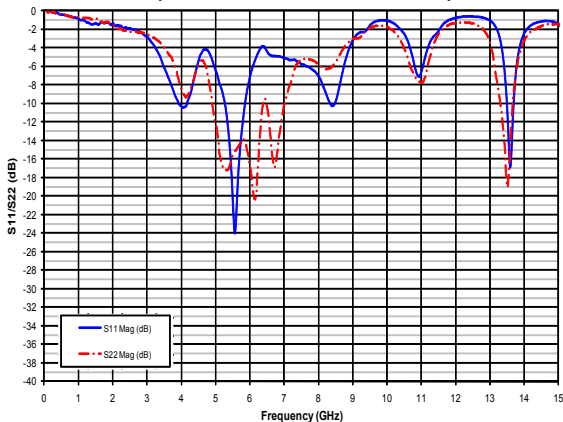

Figure 24: 5 GHz Tx Path S₁₁ & S₂₂ Return Loss (T_c = +25 °C, V_{cc} = +3.3 V)



2 GHz Rx Performance

Figure 25: 2 GHz Rx Path Noise
($T_C = +25\text{ }^\circ\text{C}$)

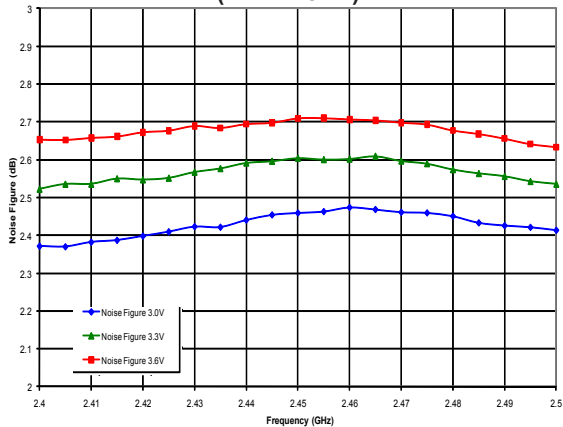

Figure 26: 2 GHz Rx Path S21 Response
($V_{CC} = +3.3\text{ V}$, $T_C = +25\text{ }^\circ\text{C}$)

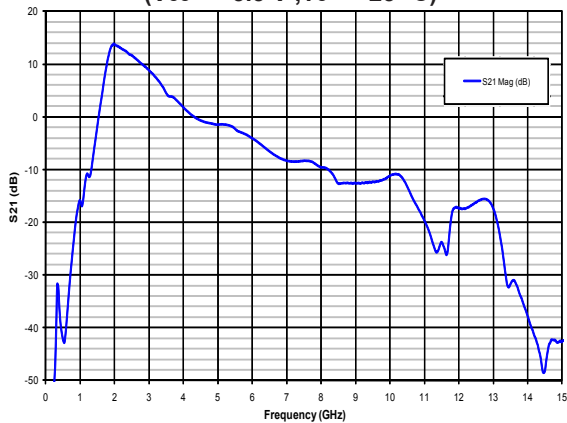
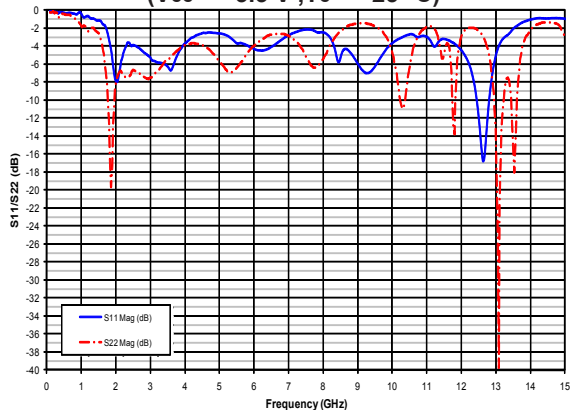

Figure 27: 2 GHz Rx Path S21 Return Loss
($V_{CC} = +3.3\text{ V}$, $T_C = +25\text{ }^\circ\text{C}$)



5 GHz Rx Performance

Figure 28: 5 GHz Rx Path Noise Figure
($T_c = +25\text{ }^\circ\text{C}$)

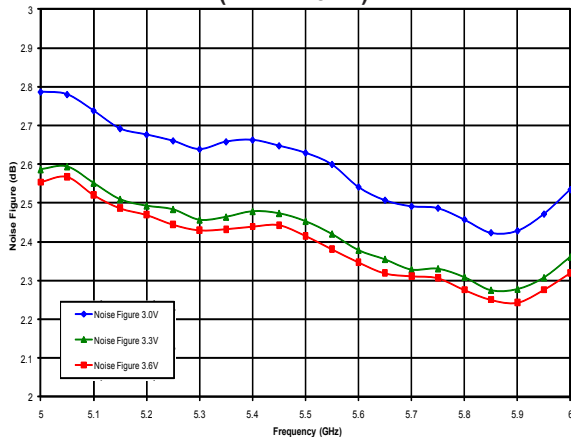

Figure 29: 5 GHz Rx Path S21 Response
($V_{cc} = +3.3\text{ V}$, $T_c = +25\text{ }^\circ\text{C}$)

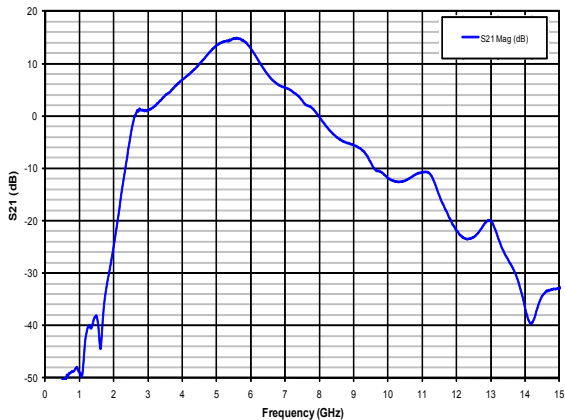
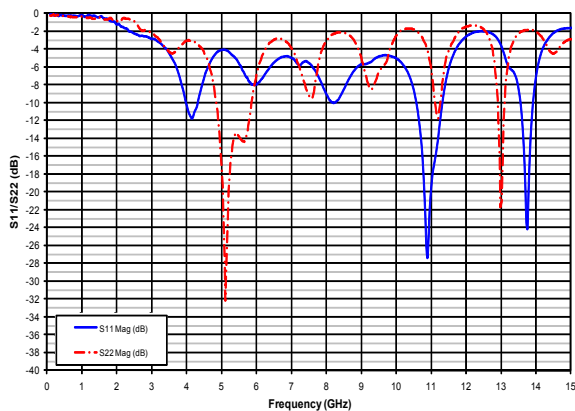

Figure 30: 5 GHz Rx Path S11 & S22 Return Loss
($V_{cc} = +3.3\text{ V}$, $T_c = +25\text{ }^\circ\text{C}$)



2 GHz and 5 GHz Rx Bypass Mode Performance

Figure 31: 2 GHz Rx Bypass Mode S21 Response
($V_{CC} = +3.3\text{ V}$, $T_C = +25\text{ }^\circ\text{C}$)

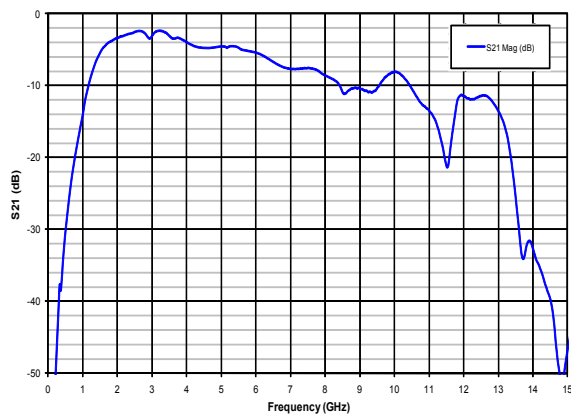

Figure 32: 2 GHz Rx Bypass Mode S11 & S22 Return Loss ($V_{CC} = +3.3\text{ V}$, $T_C = +25\text{ }^\circ\text{C}$)

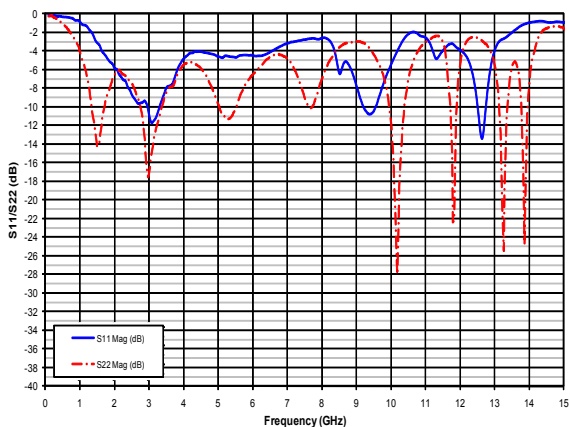

Figure 33: 5 GHz Rx Bypass Mode S21 Response
($V_{CC} = +3.3\text{ V}$, $T_C = +25\text{ }^\circ\text{C}$)

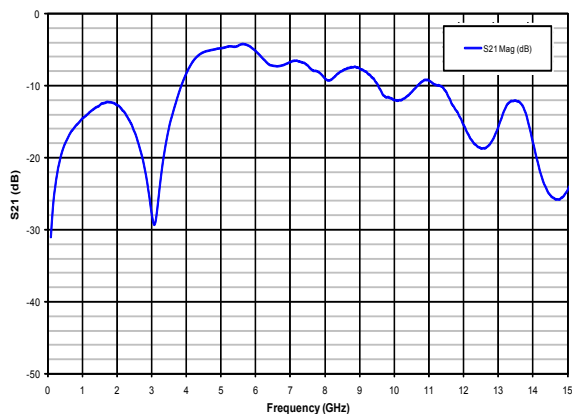
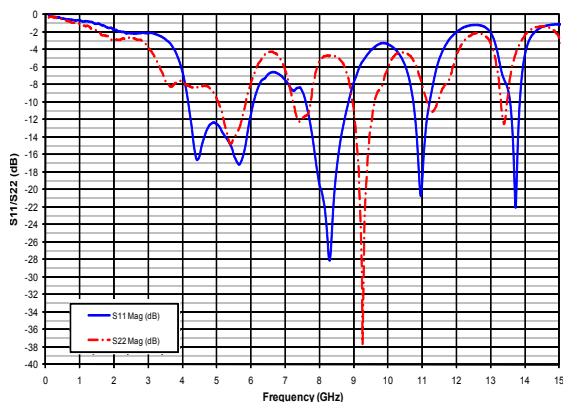

Figure 34: 5 GHz Rx Bypass Mode S21 Response
($V_{CC} = +3.3\text{ V}$, $T_C = +25\text{ }^\circ\text{C}$)



Bluetooth Performance

Figure 35: Bluetooth Path S21 Response
($V_{CC} = +3.3\text{ V}$, $T_C = +25\text{ }^\circ\text{C}$)

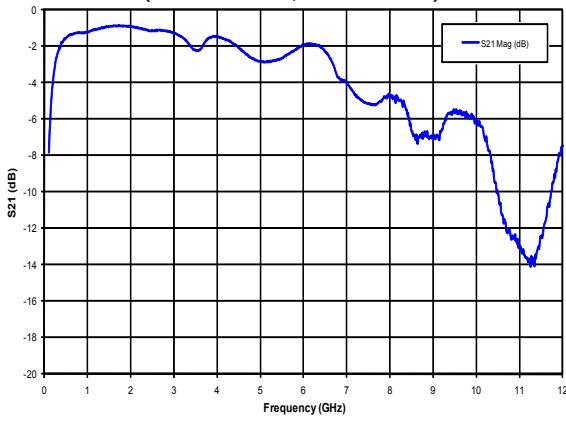
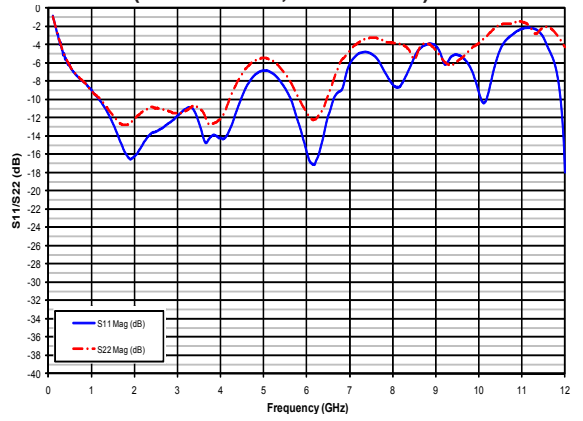
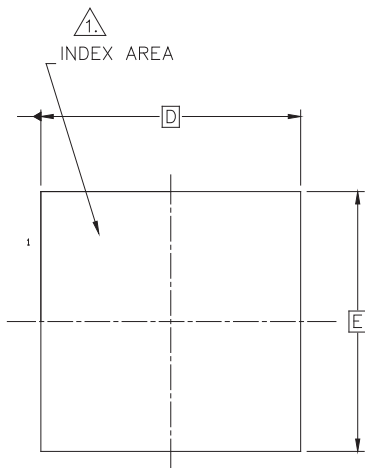
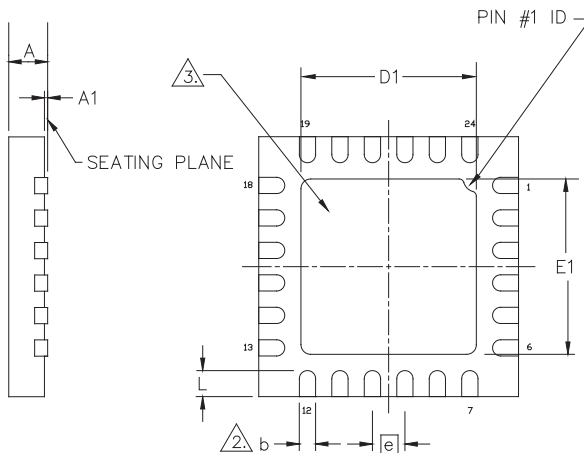

Figure 36: Bluetooth Path S11 & S22 Return Loss
($V_{CC} = +3.3\text{ V}$, $T_C = +25\text{ }^\circ\text{C}$)





TOP VIEW



SIDE VIEW

BOTTOM VIEW

S Y M B O L	DIMENSIONS—MM			N _O T E
	MIN.	NOM.	MAX.	
A	0.50	0.55	0.60	
A1	0.00	0.02	0.05	
b	0.18	0.250	0.30	
D	3.95	4.00	4.05	
D1	2.55	2.70	2.80	
E	3.95	4.00	4.05	
E1	2.55	2.70	2.80	
e	0.50 BSC			
L	0.30	0.40	0.50	

NOTES :

- 1. TERMINAL #1 IDENTIFIER AND PAD NUMBERING CONVENTION SHALL CONFORM TO JESD 95-1 SPP-012.
- 2. DIMENSION b APPLIES TO METALLIZED TERMINAL AND IS MEASURED BETWEEN 0.25 AND 0.30mm FROM TERMINAL TIP.
- 3. BILATERAL COPLANARITY ZONE APPLIES TO THE EXPOSED PAD AS WELL AS THE TERMINALS.

Figure 37: S36 Package Outline - 24 Pin 4 mm x 4 mm x 0.55 mm QFN

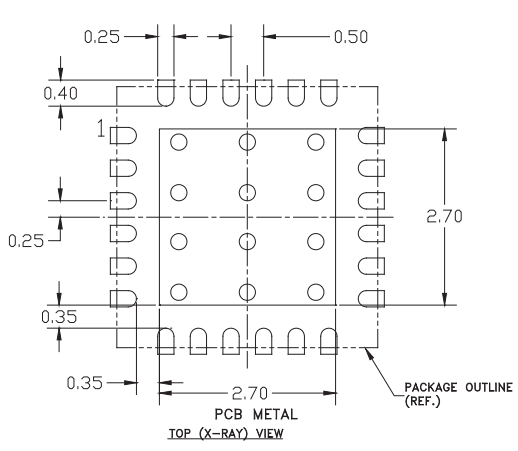

- NOTES:**
- (1) OUTLINE DRAWING REFERENCE: 98001-TBD
 - (2) UNLESS SPECIFIED DIMENSIONS ARE SYMMETRICAL ABOUT CENTER LINES SHOWN.
 - (3) DIMENSIONS IN MILLIMETERS.
 - (4) VIAS SHOWN IN PCB METAL VIEW ARE FOR REFERENCE ONLY. NUMBER & SIZE OF THERMAL VIAS REQUIRED DEPENDENT ON HEAT DISSIPATION REQUIREMENT AND THE PCB PROCESS CAPABILITY.
 - (5) RECOMMENDED STENCIL THICKNESS: APPROX. 0.125mm (5 Mils)

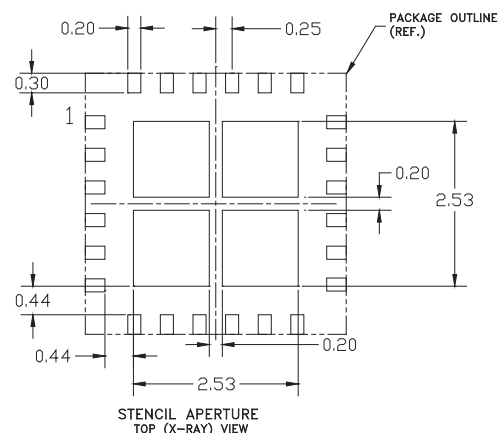
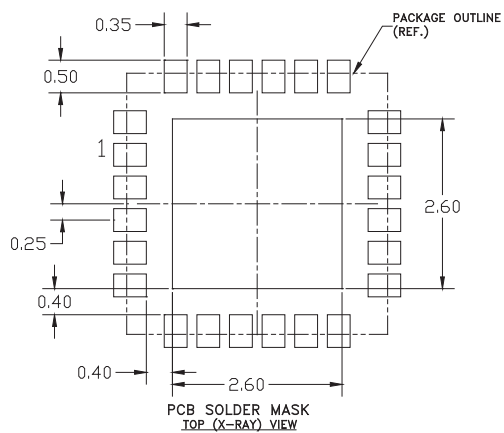

Figure 38: S36 Package Footprint - 24 Pin 4 mm x 4 mm x 0.55 mm QFN

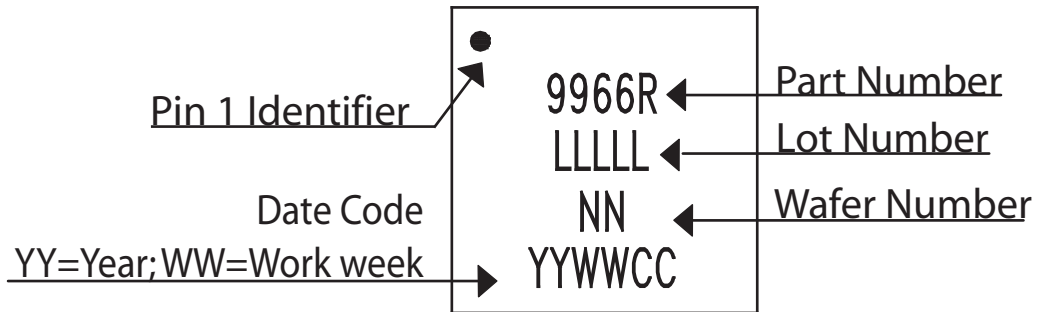

Figure 39: Branding Specification - S36 Package

APPLICATION INFORMATION

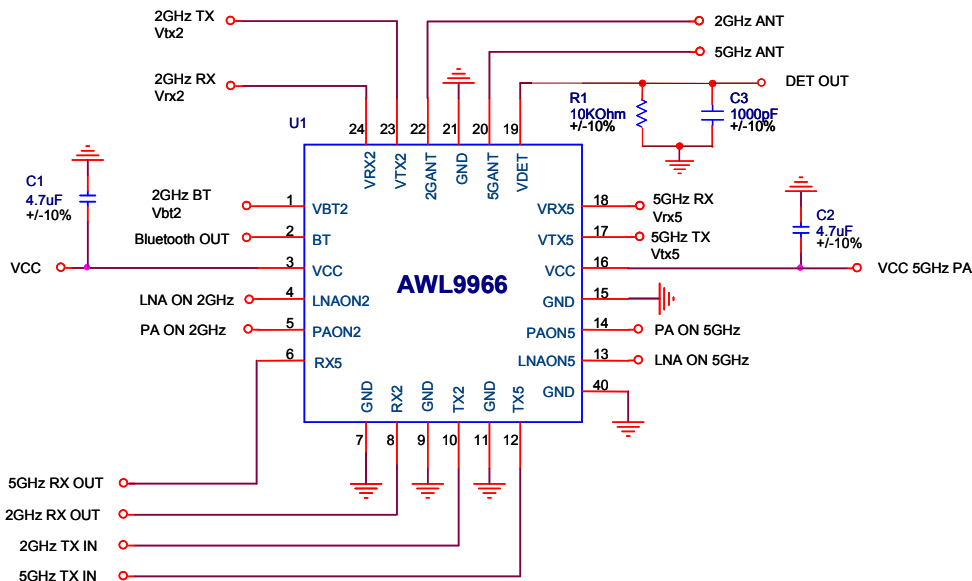

Figure 40: Application Circuit

Table 13: Switch Modes of Operation

MODES OF OPERATION	PA _{ON2}	PA _{ON5}	LNA _{ON2}	LNA _{ON5}	V _{BT2}	V _{Rx2}	V _{Tx2}	V _{Rx5}	V _{Tx5}
TX 2 GHz	HIGH	LOW	LOW	LOW	LOW	LOW	HIGH	LOW	LOW
RX 2 GHz	LOW	LOW	HIGH	LOW	LOW	HIGH	LOW	LOW	LOW
2 GHz RX Bypass	LOW	LOW	LOW	LOW	LOW	HIGH	LOW	LOW	LOW
BT 2 GHz	LOW	LOW	LOW	LOW	HIGH	LOW	LOW	LOW	LOW
BT & Bypass 2 GHz	LOW	LOW	LOW	LOW	HIGH	HIGH	LOW	LOW	LOW
BT & Rx 2 GHz	LOW	LOW	HIGH	LOW	HIGH	HIGH	LOW	LOW	LOW
TX 5 GHz	LOW	HIGH	LOW	LOW	LOW	LOW	LOW	LOW	HIGH
RX 5 GHz	LOW	LOW	LOW	HIGH	LOW	LOW	LOW	HIGH	LOW
5 GHz RX Bypass	LOW	LOW	LOW	LOW	LOW	LOW	LOW	HIGH	LOW
Power High Reset	LOW	LOW	LOW	LOW	LOW	LOW	LOW	LOW	LOW

Notes:

V_{cc} = +3.0 V to +3.6 V; Logic State LOW = 0 V to +0.5 V; Logic State HIGH = +3.0 V to +3.6 V

ORDERING INFORMATION

ORDER NUMBER	TEMPERATURE RANGE	PACKAGE DESCRIPTION	COMPONENT PACKAGING
AWL9966RS36P8	-40°C to +85°C	RoHS-Compliant 24 Pin 4 mm x 4 mm x 0.55 mm Surface Mount IC	2,500 piece Tape and Reel

**ANADIGICS, Inc.**

141 Mount Bethel Road
Warren, New Jersey 07059, U.S.A.

Tel: +1 (908) 668-5000

Fax: +1 (908) 668-5132

URL: <http://www.anadigics.com>

E-mail: Mktg@anadigics.com

IMPORTANT NOTICE

ANADIGICS, Inc. reserves the right to make changes to its products or to discontinue any product at any time without notice. The product specifications contained in Advanced Product Information sheets and Preliminary Data Sheets are subject to change prior to a product's formal introduction. Information in Data Sheets have been carefully checked and are assumed to be reliable; however, ANADIGICS assumes no responsibilities for inaccuracies. ANADIGICS strongly urges customers to verify that the information they are using is current before placing orders.

WARNING

ANADIGICS products are not intended for use in life support appliances, devices or systems. Use of an ANADIGICS product in any such application without written consent is prohibited.