

# 8-bit Proprietary Microcontrollers

CMOS

## F<sup>2</sup>MC-8FX MB95120H Series

### MB95F128H/F128T/FV100B-103

#### ■ DESCRIPTION

The MB95120H series is general-purpose, single-chip microcontrollers. In addition to a compact instruction set, the microcontrollers contain a variety of peripheral functions.

Note : F<sup>2</sup>MC is the abbreviation of FUJITSU Flexible Microcontroller.

#### ■ FEATURE

- F<sup>2</sup>MC-8FX CPU core
  - Instruction set optimized for controllers
    - Multiplication and division instructions
    - 16-bit arithmetic operations
    - Bit test branch instruction
    - Bit manipulation instructions etc.
- Clock
  - Main clock
  - Main PLL clock
  - Sub clock
  - Sub PLL clock

(Continued)

Be sure to refer to the "Check Sheet" for the latest cautions on development.

"Check Sheet" is seen at the following support page

URL : <http://www.fujitsu.com/global/services/microelectronics/product/micom/support/index.html>

"Check Sheet" lists the minimal requirement items to be checked to prevent problems beforehand in system development.

# MB95120H Series

(Continued)

- Timer
  - 8/16-bit compound timer × 2 channels
  - 16-bit reload timer
  - 8/16-bit PPG × 2 channels
  - 16-bit PPG × 2 channels
  - Timebase timer
  - Watch prescaler
- LIN-UART
  - Full duplex double buffer
  - Clock asynchronous or clock synchronous serial data transfer capable
- UART/SIO
  - Full duplex double buffer
  - Clock asynchronous or clock synchronous serial data transfer capable
- I<sup>2</sup>C\*
  - Built-in wake-up function
- External interrupt
  - Interrupt by edge detection (rising, falling, or both edges can be selected)
  - Can be used to recover from low-power consumption (standby) modes.
- 8/10-bit A/D converter
  - 8-bit or 10-bit resolution can be selected
- LCD controller (LCDC)
  - 40 SEG × 4 COM (Max 160 pixels)
  - With blinking function
- Low-power consumption (standby) mode
  - Stop mode
  - Sleep mode
  - Watch mode
  - Timebase timer mode
- I/O port
  - The number of maximum ports : Max 87
  - Port configuration
    - General-purpose I/O ports (N-ch open drain) : 2 ports
    - General-purpose I/O ports (CMOS) : 85 ports

\* : Purchase of Fujitsu I<sup>2</sup>C components conveys a license under the Philips I<sup>2</sup>C Patent Rights to use, these components in an I<sup>2</sup>C system provided that the system conforms to the I<sup>2</sup>C Standard Specification as defined by Philips.

# MB95120H Series

## ■ PRODUCT LINEUP

| Part number*1        |                                      | MB95F128H  | MB95F128T |
|----------------------|--------------------------------------|--|-----------|
| Parameter            |                                      |  |           |
| Type                 |                                      | Flash memory product   |           |
| ROM capacity         |                                      | 60K bytes  |           |
| RAM capacity         |                                      | 2K bytes   |           |
| Reset output         |                                      | Yes  |           |
| Option*2             | Clock system                         | Dual clock   |           |
|                      | Low voltage detection reset          | No   | Yes       |
| CPU functions        |                                      | Number of basic instructions : 136<br>Instruction bit length : 8 bits<br>Instruction length : 1 to 3 bytes<br>Data bit length : 1, 8, and 16 bits<br>Minimum instruction execution time : 0.1 $\mu$ s (at machine clock frequency 10 MHz)<br>Interrupt processing time : 0.9 $\mu$ s (at machine clock frequency 10 MHz)   |           |
| Peripheral functions | Ports (Max 87 ports)                 | General-purpose I/O port (N-ch open drain) : 2 ports<br>General-purpose I/O port (CMOS) : 85 ports   |           |
|                      | Timebase timer                       | Interrupt cycle : 0.5 ms, 2.1 ms, 8.2 ms, 32.8 ms (at main oscillation clock 4 MHz)  |           |
|                      | Watchdog timer                       | Reset generated cycle<br>At main oscillation clock 10 MHz : Min 105 ms<br>At sub oscillation clock 32.768 kHz : Min 250 ms   |           |
|                      | Wild register                        | Capable of replacing 3 bytes of ROM data   |           |
|                      | I <sup>2</sup> C                     | Master/slave sending and receiving<br>Bus error function and arbitration function<br>Detecting transmitting direction function<br>Start condition repeated generation and detection functions<br>Built-in wake-up function   |           |
|                      | UART/SIO                             | Data transfer capable in UART/SIO<br>Full duplex double buffer<br>Variable data length (5/6/7/8-bit), built-in baud rate generator<br>Transfer rate : 2400 bps to 1250000 bps (at machine clock 10 MHz)<br>NRZ type transfer format, error detected function<br>LSB-first or MSB-first can be selected.<br>Clock synchronous (SIO) or clock asynchronous (UART) serial data transfer capable |           |
|                      | LIN-UART                             | Dedicated reload timer allowing a wide range of communication speeds to be set.<br>Full duplex double buffer.<br>Capable of serial data transfer synchronous or asynchronous to clock signal.<br>LIN functions available as the LIN master or LIN slave.   |           |
|                      | 8/10-bit A/D converter (12 channels) | 8-bit or 10-bit resolution can be selected.  |           |

(Continued)

# MB95120H Series

(Continued)

| Part number*1        |  | MB95F128H   | MB95F128T |
|----------------------|--|---|-----------|
| Parameter            |  |   |           |
| Peripheral functions | LCD controller (LCDC)                  | COM output : 4 (Max)<br>SEG output : 40 (Max)<br>LCD drive power supply (bias) pin : 4 (Max)<br>40 SEG × 4 COM : 160 pixels can be displayed.<br>Duty LCD mode<br>With blinking function<br>Built-in division resistance for LCD drive  |           |
|                      | 16-bit reload timer                    | Two clock modes and two counter operating modes can be selected.<br>Square waveform output<br>Count clock : 7 internal clocks and external clock can be selected.<br>Counter operating mode : reload mode or one-shot mode can be selected.                                   |           |
|                      | 8/16-bit compound timer (2 channels)   | Each channel of the timer can be used as “8-bit timer × 2 channels” or “16-bit timer × 1 channel”.<br>Built-in timer function, PWC function, PWM function, capture function and square waveform output<br>Count clock : 7 internal clocks and external clock can be selected. |           |
|                      | 16-bit PPG (2 channels)                | PWM mode or one-shot mode can be selected.<br>Counter operating clock : Eight selectable clock sources<br>Support for external trigger start  |           |
|                      | 8/16-bit PPG (2 channels)              | Each channel of the PPG can be used as “8-bit PPG × 2 channels” or “16-bit PPG × 1 channel”.<br>Counter operating clock : Eight selectable clock sources  |           |
|                      | Watch counter                          | Count clock : Four selectable clock sources (125 ms, 250 ms, 500 ms, or 1 s)<br>Counter value can be set from 0 to 63. (Capable of counting for 1 minute when selecting clock source 1 second and setting counter value to 60)  |           |
|                      | Watch prescaler                        | 4 selectable interval times (125 ms, 250 ms, 500 ms, or 1 s)  |           |
|                      | External interrupt (12 channels)       | Interrupt by edge detection (rising, falling, or both edges can be selected.)<br>Can be used to recover from standby modes.   |           |
| Standby mode         | Sleep, stop, watch, and timebase timer |   |           |

\*1 : MASK ROM products are currently under consideration.

\*2 : For details of option, refer to “■ MASK OPTION”.

Note : Part number of evaluation device in MB95120 series is MB95FV100B-103. When using it, the MCU board (MB2146-303) is required.

## ■ OSCILLATION STABILIZATION WAIT TIME

The initial value of the main clock oscillation stabilization wait time is fixed to the maximum value. The maximum value is shown as follows.

| Oscillation stabilization wait time | Remarks   |
|-------------------------------------|---|
| $(2^{14}-2) / F_{CH}$               | Approx. 4.10 ms (at main oscillation clock 4 MHz) |

## ■ PACKAGES AND CORRESPONDING PRODUCTS

| Package \ Part number | MB95F128H<br>MB95F128T | MB95FV100B-103 |
|-----------------------|------------------------|----------------|
| FPT-100P-M05          | ○                      | ×              |
| FPT-100P-M06          | ○                      | ×              |
| BGA-224P-M08          | ×                      | ○              |

- : Available  
 × : Unavailable

# MB95120H Series

## ■ DIFFERENCES AMONG PRODUCTS AND NOTES ON SELECTING PRODUCTS

- Notes on Using Evaluation Products

The Evaluation product has not only the functions of the MB95120H series but also those of other products to support software development for multiple series and models of the F<sup>2</sup>MC-8FX family. The I/O addresses for peripheral resources not used by the MB95120H series are therefore access-barred. Read/write access to these access-barred addresses may cause peripheral resources supposed to be unused to operate, resulting in unexpected malfunctions of hardware or software.

Particularly, do not use word access to odd numbered byte address in the prohibited areas (If these access are used, the address may be read or written unexpectedly).

Note that the values read from barred addresses are different between the Evaluation product and the Flash memory product. Therefore, the data must not be used for software processing.

The Evaluation product do not support the functions of some bits in single-byte registers. Read/write access to these bits does not cause hardware malfunctions. The Evaluation, and Flash memory product are designed to behave completely the same way in terms of hardware and software.

- Difference of Memory Spaces

If the amount of memory on the Evaluation product is different from that of the Flash memory product, carefully check the difference in the amount of memory from the model to be actually used when developing software.

For details of memory space, refer to “■ CPU CORE”.

- Current Consumption

- For details of current consumption, refer to “■ ELECTRICAL CHARACTERISTICS”.

- Package

For details of information on each package, refer to “■ PACKAGES AND CORRESPONDING PRODUCTS” and “■ PACKAGE DIMENSIONS”.

- Operating voltage

The operating voltage are different between the Evaluation and Flash memory products.

For details of operating voltage, refer to “■ ELECTRICAL CHARACTERISTICS”.

## PIN ASSIGNMENT

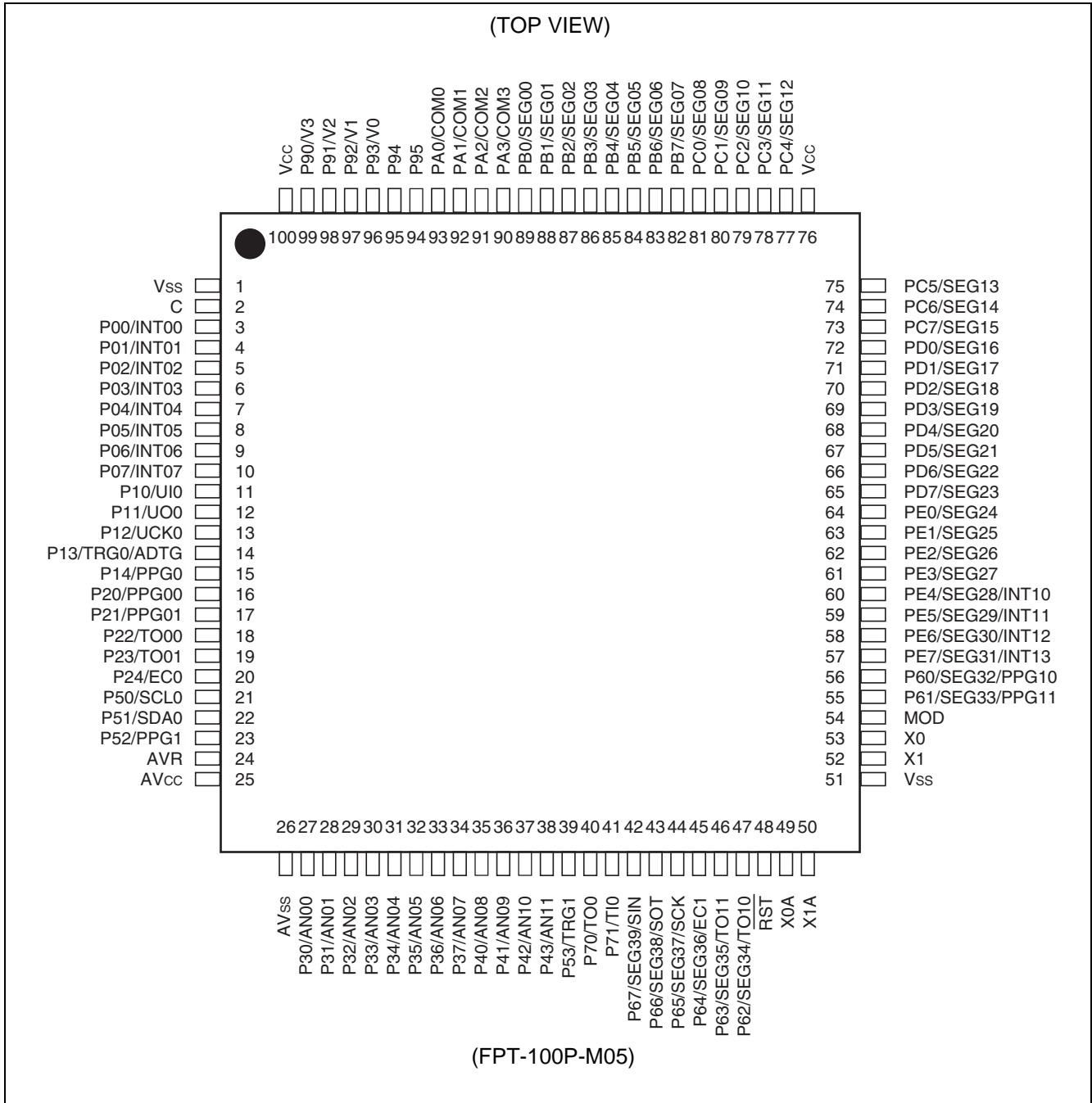

(Continued)

# MB95120H Series

(Continued)

(TOP VIEW)

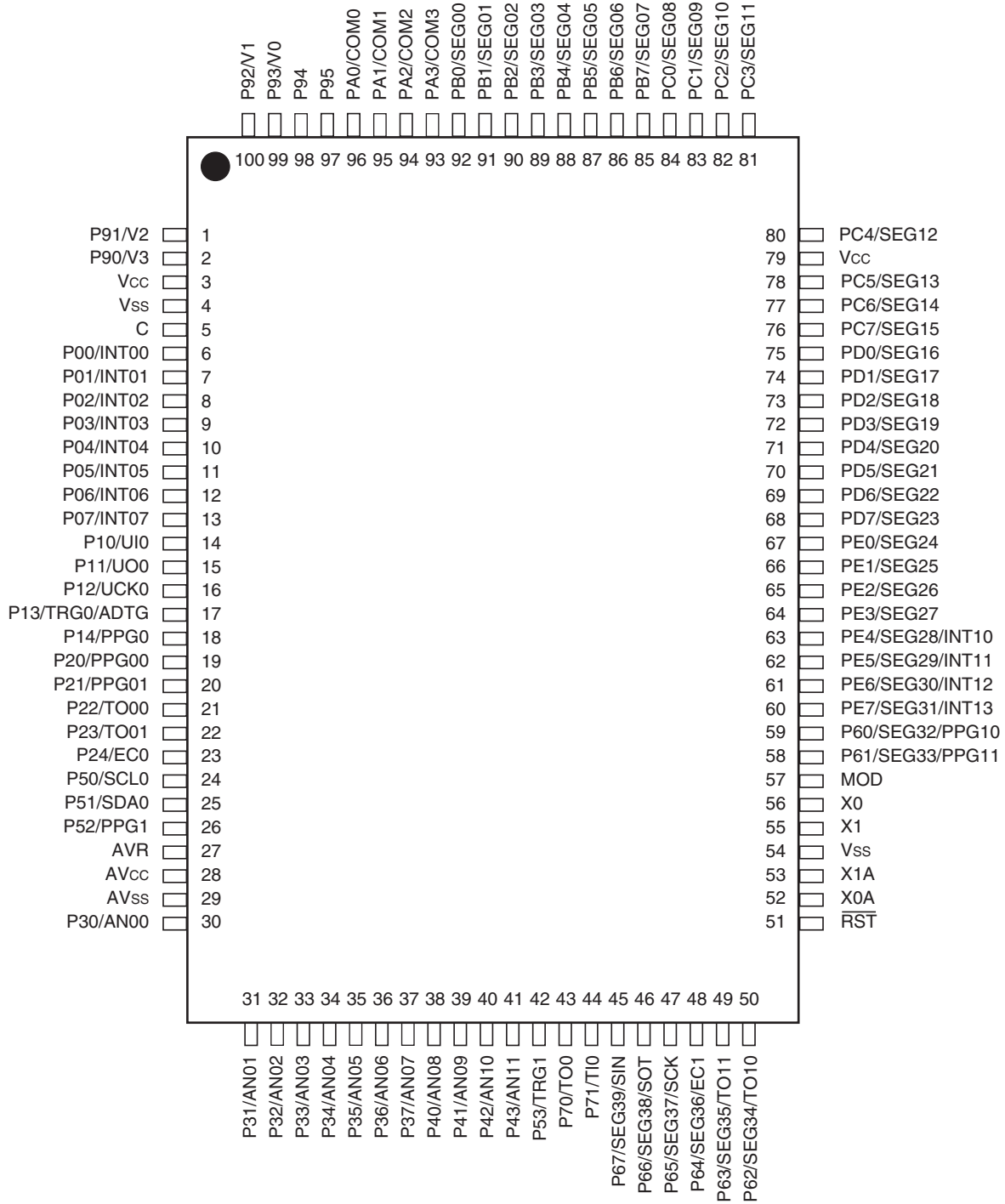

(FPT-100P-M06)

## ■ PIN DESCRIPTION

| Pin no. |        | Pin name          | I/O circuit type*3  | Function   |   |   |
|---------|--------|-------------------|---|--|---|---|
| LQFP *1 | QFP *2 |                   |   |  |   |   |
| 1       | 4      | V <sub>SS</sub>   | —   | Power supply pin (GND)   |   |   |
| 2       | 5      | C                 | —   | Capacitor connection pin   |   |   |
| 3       | 6      | P00/INT00         | C   | General-purpose I/O port<br>The pins are shared with external interrupt input. Large current port. |   |   |
| 4       | 7      | P01/INT01         |   |  |   |   |
| 5       | 8      | P02/INT02         |   |  |   |   |
| 6       | 9      | P03/INT03         |   |  |   |   |
| 7       | 10     | P04/INT04         |   |  |   |   |
| 8       | 11     | P05/INT05         |   |  |   |   |
| 9       | 12     | P06/INT06         |   |  |   |   |
| 10      | 13     | P07/INT07         |   |  |   |   |
| 11      | 14     | P10/UI0           |   |  | G | General-purpose I/O port<br>The pin is shared with UART/SIO ch.0 data input.  |
| 12      | 15     | P11/UO0           |   |  | H | General-purpose I/O port<br>The pin is shared with UART/SIO ch.0 data output. |
| 13      | 16     | P12/UCK0          | General-purpose I/O port<br>The pin is shared with UART/SIO ch.0 clock I/O.   |  |   |   |
| 14      | 17     | P13/TRG0/<br>ADTG | General-purpose I/O port<br>The pin is shared with 16-bit PPG ch.0 trigger input (TRG0) and A/D trigger input (ADTG). |  |   |   |
| 15      | 18     | P14/PPG0          | General-purpose I/O port<br>The pin is shared with 16-bit PPG ch.0 output.  |  |   |   |
| 16      | 19     | P20/PPG00         | H   | General-purpose I/O port<br>The pins are shared with 8/16-bit compound timer ch.0 output.          |   |   |
| 17      | 20     | P21/PPG01         |   |  |   |   |
| 18      | 21     | P22/TO00          |   |  |   |   |
| 19      | 22     | P23/TO01          |   |  |   |   |
| 20      | 23     | P24/EC0           |   | General-purpose I/O port<br>The pin is shared with 8/16-bit compound timer ch.0 clock input.       |   |   |
| 21      | 24     | P50/SCL0          | I   | General-purpose I/O port<br>The pin is shared with I <sup>2</sup> C ch.0 clock I/O.                |   |   |
| 22      | 25     | P51/SDA0          |   | General-purpose I/O port<br>The pin is shared with I <sup>2</sup> C ch.0 data I/O.                 |   |   |
| 23      | 26     | P52/PPG1          | H   | General-purpose I/O port<br>The pin is shared with 16-bit PPG ch.1 output.                         |   |   |
| 24      | 27     | AVR               | —   | A/D converter reference input pin  |   |   |
| 25      | 28     | AV <sub>CC</sub>  | —   | A/D converter power supply pin   |   |   |

(Continued)

# MB95120H Series

| Pin no. |        | Pin name           | I/O circuit type*3 | Function   |
|---------|--------|--------------------|--------------------|--|
| LQFP *1 | QFP *2 |                    |                    |  |
| 26      | 29     | AV <sub>ss</sub>   | —                  | A/D converter power supply pin (GND)   |
| 27      | 30     | P30/AN00           | J                  | General-purpose I/O port<br>The pins are shared with A/D converter analog input.   |
| 28      | 31     | P31/AN01           |                    |  |
| 29      | 32     | P32/AN02           |                    |  |
| 30      | 33     | P33/AN03           |                    |  |
| 31      | 34     | P34/AN04           |                    |  |
| 32      | 35     | P35/AN05           |                    |  |
| 33      | 36     | P36/AN06           |                    |  |
| 34      | 37     | P37/AN07           |                    |  |
| 35      | 38     | P40/AN08           | J                  | General-purpose I/O port<br>The pins are shared with A/D converter analog input.   |
| 36      | 39     | P41/AN09           |                    |  |
| 37      | 40     | P42/AN10           |                    |  |
| 38      | 41     | P43/AN11           |                    |  |
| 39      | 42     | P53/TRG1           | H                  | General-purpose I/O port<br>The pin is shared with 16 - bit PPG ch.1 trigger input.  |
| 40      | 43     | P70/TO0            | H                  | General-purpose I/O port<br>The pin is shared with 16 - bit reload timer ch.0 output.  |
| 41      | 44     | P71/TI0            |                    | General-purpose I/O port<br>The pin is shared with 16 - bit reload timer ch.0 input.   |
| 42      | 45     | P67/SEG39/<br>SIN  | N                  | General-purpose I/O port<br>The pin is shared with LIN-UART data input (SIN) and LCDC SEG output (SEG39) .                                 |
| 43      | 46     | P66/SEG38/<br>SOT  | M                  | General-purpose I/O port<br>The pin is shared with LIN-UART data output (SOT) and LCDC SEG output (SEG38) .                                |
| 44      | 47     | P65/SEG37/<br>SCK  |                    | General-purpose I/O port<br>The pins are shared with LIN-UART clock I/O (SCK) and LCDC SEG output (SEG37) .                                |
| 45      | 48     | P64/SEG36/<br>EC1  |                    | General-purpose I/O port<br>The pins are shared with 8/16-bit compound timer ch.1 clock input (EC1) and LCDC SEG output (SEG36) .          |
| 46      | 49     | P63/SEG35/<br>TO11 |                    | General-purpose I/O port<br>The pins are shared with 8/16-bit compound timer ch.1 output (TO10, TO11) and LCDC SEG output (SEG34, SEG35) . |
| 47      | 50     | P62/SEG34/<br>TO10 |                    |  |
| 48      | 51     | $\overline{RST}$   |                    | B'   |
| 49      | 52     | X0A                | A                  | Sub clock oscillation pin (32 kHz)   |
| 50      | 53     | X1A                |                    |  |
| 51      | 54     | V <sub>ss</sub>    | —                  | Power supply pin (GND)   |

(Continued)

# MB95120H Series

| Pin no. |        | Pin name             | I/O circuit type*3 | Function  |
|---------|--------|----------------------|--------------------|---|
| LQFP *1 | QFP *2 |                      |                    |   |
| 52      | 55     | X1                   | A                  | Main clock oscillation pin  |
| 53      | 56     | X0                   |                    |   |
| 54      | 57     | MOD                  | B                  | An operating mode designation pin   |
| 55      | 58     | P61/SEG33/<br>PPG11  | M                  | General-purpose I/O port<br>The pins are shared with 8/16-bit PPG ch.1 output (PPG10, PPG11) and LCDC SEG output (SEG32, SEG33) .       |
| 56      | 59     | P60/SEG32/<br>PPG10  |                    |   |
| 57      | 60     | PE7/SEG31/<br>INIT13 | Q                  | General-purpose I/O port<br>The pins are shared with external interrupt input (INIT10 to INIT13) and LCDC SEG output (SEG28 to SEG31) . |
| 58      | 61     | PE6/SEG30/<br>INIT12 |                    |   |
| 59      | 62     | PE5/SEG29/<br>INIT11 |                    |   |
| 60      | 63     | PE4/SEG28/<br>INIT10 |                    |   |
| 61      | 64     | PE3/SEG27            | M                  | General-purpose I/O port<br>The pins are shared with LCDC SEG output.   |
| 62      | 65     | PE2/SEG26            |                    |   |
| 63      | 66     | PE1/SEG25            |                    |   |
| 64      | 67     | PE0/SEG24            |                    |   |
| 65      | 68     | PD7/SEG23            | M                  | General-purpose I/O port<br>The pins are shared with LCDC SEG output.   |
| 66      | 69     | PD6/SEG22            |                    |   |
| 67      | 70     | PD5/SEG21            |                    |   |
| 68      | 71     | PD4/SEG20            |                    |   |
| 69      | 72     | PD3/SEG19            |                    |   |
| 70      | 73     | PD2/SEG18            |                    |   |
| 71      | 74     | PD1/SEG17            |                    |   |
| 72      | 75     | PD0/SEG16            |                    |   |
| 73      | 76     | PC7/SEG15            | M                  | General-purpose I/O port<br>The pins are shared with LCDC SEG output.   |
| 74      | 77     | PC6/SEG14            |                    |   |
| 75      | 78     | PC5/SEG13            |                    |   |
| 76      | 79     | V <sub>cc</sub>      | —                  | Power supply pin  |

(Continued)

# MB95120H Series

(Continued)

| Pin no. |        | Pin name        | I/O circuit type*3 | Function   |
|---------|--------|-----------------|--------------------|--|
| LQFP *1 | QFP *2 |                 |                    |  |
| 77      | 80     | PC4/SEG12       | M                  | General-purpose I/O port<br>The pins are shared with LCDC SEG output.                  |
| 78      | 81     | PC3/SEG11       |                    |  |
| 79      | 82     | PC2/SEG10       |                    |  |
| 80      | 83     | PC1/SEG09       |                    |  |
| 81      | 84     | PC0/SEG08       |                    |  |
| 82      | 85     | PB7/SEG07       | M                  | General-purpose I/O port<br>The pins are shared with LCDC SEG output.                  |
| 83      | 86     | PB6/SEG06       |                    |  |
| 84      | 87     | PB5/SEG05       |                    |  |
| 85      | 88     | PB4/SEG04       |                    |  |
| 86      | 89     | PB3/SEG03       |                    |  |
| 87      | 90     | PB2/SEG02       |                    |  |
| 88      | 91     | PB1/SEG01       |                    |  |
| 89      | 92     | PB0/SEG00       | M                  | General-purpose I/O port<br>The pins are shared with LCDC COM output.                  |
| 90      | 93     | PA3/COM3        |                    |  |
| 91      | 94     | PA2/COM2        |                    |  |
| 92      | 95     | PA1/COM1        |                    |  |
| 93      | 96     | PA0/COM0        | M                  | General-purpose I/O port   |
| 94      | 97     | P95             |                    |  |
| 95      | 98     | P94             | R                  | General-purpose I/O port<br>The pins are shared with power supply pins for LCDC drive. |
| 96      | 99     | P93/V0          |                    |  |
| 97      | 100    | P92/V1          |                    |  |
| 98      | 1      | P91/V2          |                    |  |
| 99      | 2      | P90/V3          | —                  | Power supply pin   |
| 100     | 3      | V <sub>CC</sub> |                    |  |

\*1 : FPT-100P-M05

\*2 : FPT-100P-M06

\*3 : For the I/O circuit type, refer to "■ I/O CIRCUIT TYPE".

## ■ I/O CIRCUIT TYPE

| Type | Circuit   | Remarks   |
|------|---|---|
| A    | <p>Standby control</p>  | <ul style="list-style-type: none"> <li>• Oscillation circuit</li> <li>• High-speed side<br/>Feedback resistance : approx. 1 MΩ</li> <li>• Low-speed side<br/>Feedback resistance : approx. 10 MΩ</li> </ul> |
| B    | <p>Mode input</p>   | <ul style="list-style-type: none"> <li>• Only for input</li> <li>• Hysteresis input</li> </ul>  |
| B'   | <p>Reset input</p> <p>Reset output</p>  | <ul style="list-style-type: none"> <li>• Reset output</li> <li>• Hysteresis input</li> </ul>  |
| C    | <p>Digital output</p> <p>Digital output</p> <p>Hysteresis input</p> <p>Standby control</p> <p>External interrupt enable</p>         | <ul style="list-style-type: none"> <li>• CMOS output</li> <li>• Hysteresis input</li> </ul>   |
| G    | <p>Pull-up control</p> <p>Digital output</p> <p>Digital output</p> <p>CMOS input</p> <p>Hysteresis input</p> <p>Standby control</p> | <ul style="list-style-type: none"> <li>• CMOS output</li> <li>• CMOS input</li> <li>• Hysteresis input</li> <li>• With pull-up control</li> </ul>   |
| H    | <p>Pull-up control</p> <p>Digital output</p> <p>Digital output</p> <p>Hysteresis input</p> <p>Standby control</p>                   | <ul style="list-style-type: none"> <li>• CMOS output</li> <li>• Hysteresis input</li> <li>• With pull-up control</li> </ul>   |

(Continued)

# MB95120H Series

| Type | Circuit   | Remarks   |
|------|---|---|
| I    | <p>Standby control</p> <p>N-ch</p> <p>Digital output</p> <p>CMOS input</p> <p>Hysteresis input</p>  | <ul style="list-style-type: none"> <li>• N-ch open drain output</li> <li>• CMOS input</li> <li>• Hysteresis input</li> </ul>                        |
| J    | <p>R</p> <p>P-ch</p> <p>Pull-up control</p> <p>P-ch</p> <p>Digital output</p> <p>Digital output</p> <p>N-ch</p> <p>Analog input</p> <p>A/D control</p> <p>Hysteresis input</p> <p>Standby control</p> | <ul style="list-style-type: none"> <li>• CMOS output</li> <li>• Hysteresis input</li> <li>• Analog input</li> <li>• With pull-up control</li> </ul> |
| M    | <p>P-ch</p> <p>Digital output</p> <p>Digital output</p> <p>N-ch</p> <p>LCD output</p> <p>LCD control</p> <p>Standby control</p> <p>Hysteresis input</p>   | <ul style="list-style-type: none"> <li>• CMOS output</li> <li>• LCD output</li> <li>• Hysteresis input</li> </ul>                                   |
| N    | <p>P-ch</p> <p>Digital output</p> <p>Digital output</p> <p>N-ch</p> <p>LCD output</p> <p>LCD control</p> <p>Standby control</p> <p>CMOS input</p> <p>Hysteresis input</p>                             | <ul style="list-style-type: none"> <li>• CMOS output</li> <li>• LCD output</li> <li>• CMOS input</li> <li>• Hysteresis input</li> </ul>             |

(Continued)

(Continued)

| Type | Circuit   | Remarks   |
|------|---|---|
| Q    | <p>P-ch — Digital output</p> <p>N-ch — Digital output</p> <p>LCD output</p> <p>Hysteresis input</p> <p>LCD control</p> <p>Standby control</p> <p>External interrupt control</p> | <ul style="list-style-type: none"> <li>• CMOS output</li> <li>• LCD output</li> <li>• Hysteresis input</li> </ul>       |
| R    | <p>P-ch — Digital output</p> <p>N-ch — Digital output</p> <p>LCD built-in division resistance I/O</p> <p>Hysteresis input</p> <p>LCD control</p> <p>Standby control</p>         | <ul style="list-style-type: none"> <li>• CMOS output</li> <li>• LCD power supply</li> <li>• Hysteresis input</li> </ul> |

# MB95120H Series

## ■ CAUTION OF USING DEVICES

### • Preventing Latch-up

Care must be taken to ensure that maximum voltage ratings are not exceeded when they are used.

Latch-up may occur on CMOS ICs if voltage higher than  $V_{CC}$  or lower than  $V_{SS}$  is applied to input and output pins other than medium- and high-withstand voltage pins or if higher than the rating voltage is applied between  $V_{CC}$  pin and  $V_{SS}$  pin.

When latch-up occurs, power supply current increases rapidly and might thermally damage elements.

Also, take care to prevent the analog power supply voltage ( $AV_{CC}$ ,  $AVR$ ) and analog input voltage from exceeding the digital power supply voltage ( $V_{CC}$ ) when the analog system power supply is turned on or off.

### • Stable Supply Voltage

Supply voltage should be stabilized.

A sudden change in power-supply voltage may cause a malfunction even within the guaranteed operating range of the  $V_{CC}$  power-supply voltage.

For stabilization, in principle, keep the variation in  $V_{CC}$  ripple (p-p value) in a commercial frequency range (50/60 Hz) not to exceed 10% of the standard  $V_{CC}$  value and suppress the voltage variation so that the transient variation rate does not exceed 0.1 V/ms during a momentary change such as when the power supply is switched.

### • Precautions for Use of External Clock

Even when an external clock is used, oscillation stabilization wait time is required for power-on reset, wake-up from sub clock mode or stop mode.

## ■ PIN CONNECTION

### • Treatment of Unused Pin

Leaving unused input pins unconnected can cause abnormal operation or latch-up, leaving to permanent damage.

Unused input pins should always be pulled up or down through resistance of at least 2 k $\Omega$ . Any unused input/output pins may be set to output mode and left open, or set to input mode and treated the same as unused input pins. If there is unused output pin, make it open.

### • Treatment of Power Supply Pins on A/D Converter

Connect to be  $AV_{CC} = V_{CC}$  and  $AV_{SS} = AVR = V_{SS}$  even if the A/D converter is not in use.

Noise riding on the  $AV_{CC}$  pin may cause accuracy degradation. So, connect approx. 0.1  $\mu$ F ceramic capacitor as a bypass capacitor between  $AV_{CC}$  and  $AV_{SS}$  pins in the vicinity of this device.

### • Power Supply Pins

In products with multiple  $V_{CC}$  or  $V_{SS}$  pins, the pins of the same potential are internally connected in the device to avoid abnormal operations including latch-up. However, you must connect the pins to external power supply and a ground line to lower the electro-magnetic emission level, to prevent abnormal operation of strobe signals caused by the rise in the ground level, and to conform to the total output current rating.

Moreover, connect the current supply source with the  $V_{CC}$  and  $V_{SS}$  pins of this device at the low impedance.

It is also advisable to connect a ceramic bypass capacitor of approximately 0.1  $\mu$ F between  $V_{CC}$  and  $V_{SS}$  near this device.

- Mode Pin (MOD)

Connect the mode pin directly to  $V_{CC}$  or  $V_{SS}$  pins.

To prevent the device unintentionally entering test mode due to noise, lay out the printed circuit board so as to minimize the distance from the mode pins to  $V_{CC}$  or  $V_{SS}$  pins and to provide a low-impedance connection.

Use a ceramic capacitor or a capacitor with equivalent frequency characteristics. A bypass capacitor of  $V_{CC}$  pin must have a capacitance value higher than  $C_s$ . For connection of smoothing capacitor  $C_s$ , see the diagram below.

- C pin connection diagram

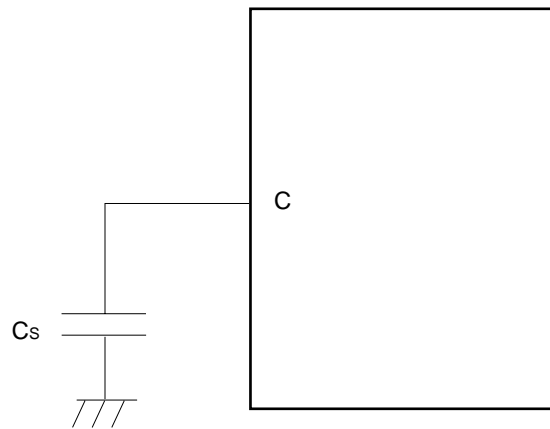

- Analog Power Supply

Always set the same potential to  $AV_{CC}$  and  $V_{CC}$  pins. When  $V_{CC} > AV_{CC}$ , the current may flow through the AN00 to AN11 pins.

# MB95120H Series

## PROGRAMMING FLASH MEMORY MICROCONTROLLERS USING PARALLEL PROGRAMMER

### Supported Parallel Programmers and Adapters

| Package      | Applicable adapter model | Parallel programmers   |
|--------------|--------------------------|--|
| FPT-100P-M05 | TEF110-95F128HSPFV       | AF9708 (Ver 02.35G or more)<br>AF9709/B (Ver 02.35G or more)<br>AF9723+AF9834 (Ver 02.08E or more) |
| FPT-100P-M06 | TEF110-95F128HSPF        |  |

Note : For information on applicable adapter models and parallel programmers, contact the following:  
Flash Support Group, Inc. TEL: +81-53-428-8380

### Sector Configuration

The individual sectors of Flash memory correspond to addresses used for CPU access and programming by the parallel programmer as follows:

| Flash memory    | CPU address       | Programmer address* |
|-----------------|-------------------|---------------------|
| SA1 (4K bytes)  | 1000 <sub>H</sub> | 71000 <sub>H</sub>  |
| SA2 (4K bytes)  | 1FFF <sub>H</sub> | 71FFF <sub>H</sub>  |
|                 | 2000 <sub>H</sub> | 72000 <sub>H</sub>  |
| SA3 (4K bytes)  | 2FFF <sub>H</sub> | 72FFF <sub>H</sub>  |
|                 | 3000 <sub>H</sub> | 73000 <sub>H</sub>  |
| SA4 (16K bytes) | 3FFF <sub>H</sub> | 73FFF <sub>H</sub>  |
|                 | 4000 <sub>H</sub> | 74000 <sub>H</sub>  |
| SA5 (16K bytes) | 7FFF <sub>H</sub> | 77FFF <sub>H</sub>  |
|                 | 8000 <sub>H</sub> | 78000 <sub>H</sub>  |
| SA6 (4K bytes)  | BFFF <sub>H</sub> | 7BFFF <sub>H</sub>  |
|                 | C000 <sub>H</sub> | 7C000 <sub>H</sub>  |
| SA7 (4K bytes)  | CFFF <sub>H</sub> | 7CFFF <sub>H</sub>  |
|                 | D000 <sub>H</sub> | 7D000 <sub>H</sub>  |
| SA8 (4K bytes)  | DFFF <sub>H</sub> | 7DFFF <sub>H</sub>  |
|                 | E000 <sub>H</sub> | 7E000 <sub>H</sub>  |
| SA9 (4K bytes)  | EFFF <sub>H</sub> | 7EFFF <sub>H</sub>  |
|                 | F000 <sub>H</sub> | 7F000 <sub>H</sub>  |
|                 | FFF <sub>H</sub>  | 7FFF <sub>H</sub>   |

\*: Programmer addresses are corresponding to CPU addresses, used when the parallel programmer programs data into Flash memory.  
These programmer addresses are used for the parallel programmer to program or erase data in Flash memory.

### Programming Method

- 1) Set the type code of the parallel programmer to 17222.
- 2) Load program data to programmer addresses 71000<sub>H</sub> to 7FFFF<sub>H</sub>.
- 3) Programmed by parallel programmer

## ■ BLOCK DIAGRAM

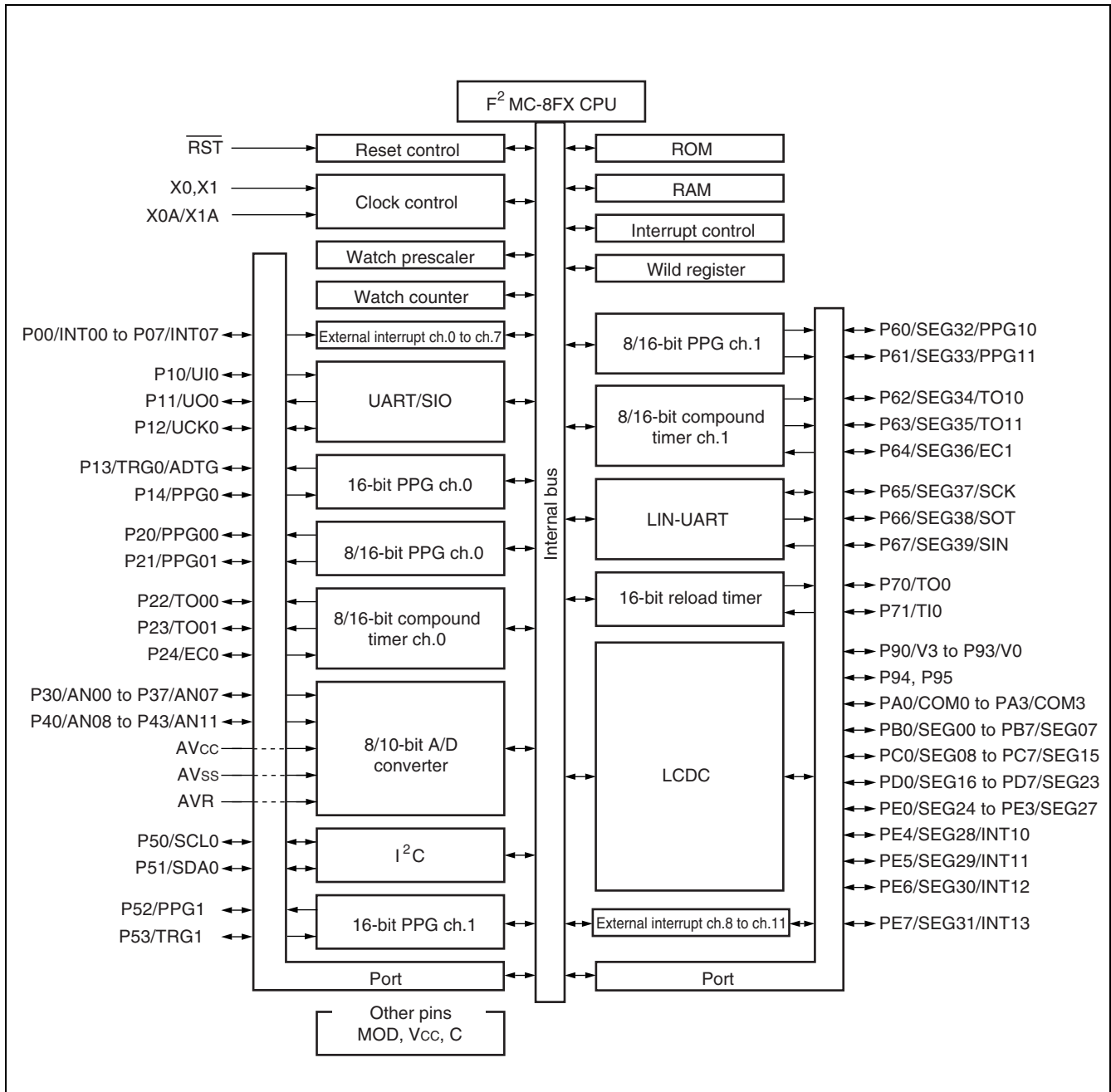

# MB95120H Series

## ■ CPU CORE

### 1. Memory space

Memory space of the MB95120H series is 64K bytes and consists of I/O area, data area, and program area. The memory space includes special - purpose areas such as the general - purpose registers and vector table. Memory map of the MB95120H series is shown below.

- Memory Map

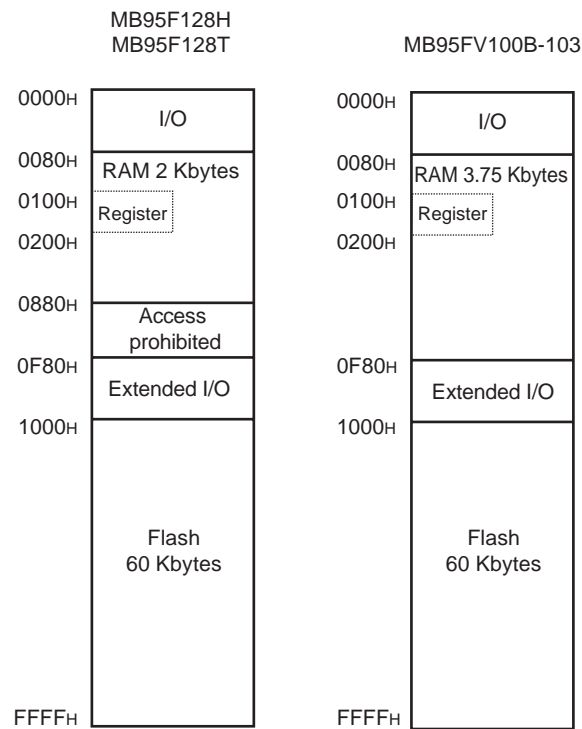

## 2. Register

The MB95120H series has two types of registers; dedicated registers in the CPU and general-purpose registers in the memory. The dedicated registers are as follows:

- Program counter (PC) : A 16-bit register to indicate locations where instructions are stored.
- Accumulator (A) : A 16-bit register for temporary storage of arithmetic operations. In the case of an 8-bit data processing instruction, the lower 1 byte is used.
- Temporary accumulator (T) : A 16-bit register which performs arithmetic operations with the accumulator. In the case of an 8-bit data processing instruction, the lower 1 byte is used.
- Index register (IX) : A 16-bit register for index modification
- Extra pointer (EP) : A 16-bit pointer to point to a memory address.
- Stack pointer (SP) : A 16-bit register to indicate a stack area.
- Program status (PS) : A 16-bit register for storing a register bank pointer, a direct bank pointer, and a condition code register

| 16-bit |                         | Initial Value     |
|--------|-------------------------|-------------------|
| PC     | : Program counter       | FFFD <sub>H</sub> |
| A      | : Accumulator           | 0000 <sub>H</sub> |
| T      | : Temporary accumulator | 0000 <sub>H</sub> |
| IX     | : Index register        | 0000 <sub>H</sub> |
| EP     | : Extra pointer         | 0000 <sub>H</sub> |
| SP     | : Stack pointer         | 0000 <sub>H</sub> |
| PS     | : Program status        | 0030 <sub>H</sub> |

The PS can further be divided into higher 8 bits for use as a register bank pointer (RP) and a direct bank pointer (DP) and the lower 8 bits for use as a condition code register (CCR) . (See the diagram below.)

### • Structure of the program status

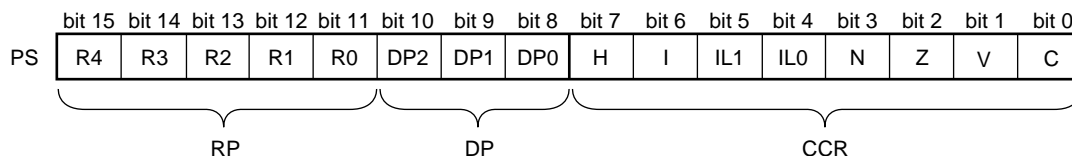

# MB95120H Series

The RP indicates the address of the register bank currently being used. The relationship between the content of RP and the real address conforms to the conversion rule illustrated below:

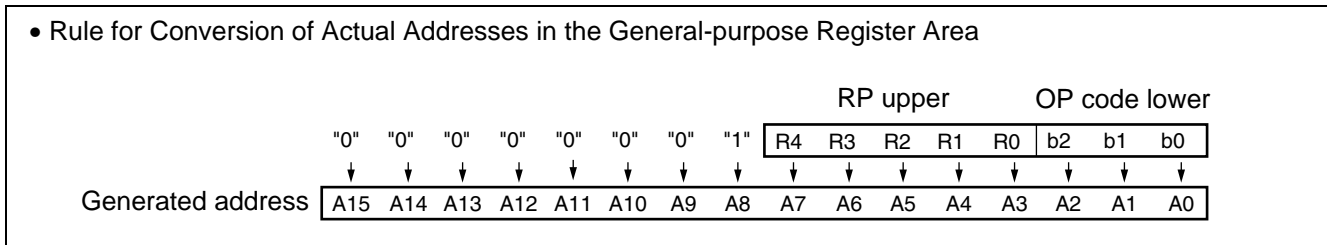

The DP specifies the area for mapping instructions (16 different instructions such as MOV A, dir) using direct addresses to 0080H to 00FFH.

| Direct bank pointer (DP2 to DP0)        | Specified address area                 | Mapping area   |
|---|--|--|
| XXX <sub>B</sub> (no effect to mapping) | 0000 <sub>H</sub> to 007F <sub>H</sub> | 0000 <sub>H</sub> to 007F <sub>H</sub> (without mapping) |
| 000 <sub>B</sub> (initial value)        | 0080 <sub>H</sub> to 00FF <sub>H</sub> | 0080 <sub>H</sub> to 00FF <sub>H</sub> (without mapping) |
| 001 <sub>B</sub>                        |  | 0100 <sub>H</sub> to 017F <sub>H</sub>                   |
| 010 <sub>B</sub>                        |  | 0180 <sub>H</sub> to 01FF <sub>H</sub>                   |
| 011 <sub>B</sub>                        |  | 0200 <sub>H</sub> to 027F <sub>H</sub>                   |
| 100 <sub>B</sub>                        |  | 0280 <sub>H</sub> to 02FF <sub>H</sub>                   |
| 101 <sub>B</sub>                        |  | 0300 <sub>H</sub> to 037F <sub>H</sub>                   |
| 110 <sub>B</sub>                        |  | 0380 <sub>H</sub> to 03FF <sub>H</sub>                   |
| 111 <sub>B</sub>                        |  | 0400 <sub>H</sub> to 047F <sub>H</sub>                   |

The CCR consists of the bits indicating arithmetic operation results or transfer data contents and the bits that control CPU operations at interrupt.

- H flag : Set to "1" when a carry or a borrow from bit 3 to bit 4 occurs as a result of an arithmetic operation. Cleared to "0" otherwise. This flag is for decimal adjustment instructions.
- I flag : Interrupt is enabled when this flag is set to "1". Interrupt is disabled when this flag is set to "0". The flag is cleared to "0" when reset.
- IL1, IL0 : Indicates the level of the interrupt currently enabled. Processes an interrupt only if its request level is higher than the value indicated by these bits.

| IL1 | IL0 | Interrupt level | Priority                                |
|-----|-----|-----------------|---|
| 0   | 0   | 0               | High<br>↑<br>↓<br>Low = no interruption |
| 0   | 1   | 1               |   |
| 1   | 0   | 2               |   |
| 1   | 1   | 3               |   |

- N flag : Set to "1" if the MSB is set to "1" as the result of an arithmetic operation. Cleared to "0" when the bit is set to "0".
- Z flag : Set to "1" when an arithmetic operation results in "0". Cleared to "0" otherwise.
- V flag : Set to "1" if the complement on 2 overflows as a result of an arithmetic operation. Cleared to "0" otherwise.
- C flag : Set to "1" when a carry or a borrow from bit 7 occurs as a result of an arithmetic operation. Cleared to "0" otherwise. Set to the shift-out value in the case of a shift instruction.

The following general-purpose registers are provided:

General-purpose registers: 8-bit data storage registers

The general-purpose registers are 8 bits and located in the register banks on the memory. 1-bank contains 8-registers. Up to a total of 32 banks can be used on the MB95120H series. The bank currently in use is indicated by the register bank pointer (RP).8-register. Up to a total of 32 banks can be used on the MB95120H series. The bank currently in use is specified by the register bank pointer (RP), and the lower 3 bits of OP code indicates the general-purpose register 0 (R0) to general-purpose register 7 (R7).

• Register Bank Configuration

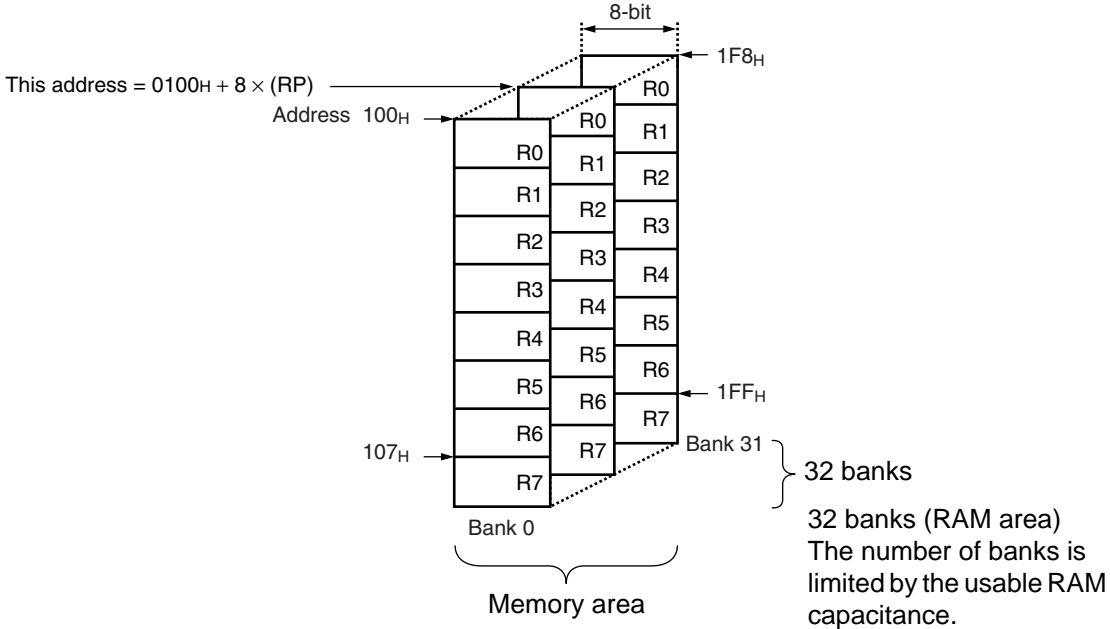

# MB95120H Series

## ■ I/O MAP

| Address                                  | Register abbreviation | Register name  | R/W | Initial value         |
|--|-----------------------|--|-----|-----------------------|
| 0000 <sub>H</sub>                        | PDR0                  | Port 0 data register                                 | R/W | 00000000 <sub>B</sub> |
| 0001 <sub>H</sub>                        | DDR0                  | Port 0 direction register                            | R/W | 00000000 <sub>B</sub> |
| 0002 <sub>H</sub>                        | PDR1                  | Port 1 data register                                 | R/W | 00000000 <sub>B</sub> |
| 0003 <sub>H</sub>                        | DDR1                  | Port 1 direction register                            | R/W | 00000000 <sub>B</sub> |
| 0004 <sub>H</sub>                        | —                     | (Disabled)   | —   | —                     |
| 0005 <sub>H</sub>                        | WATR                  | Oscillation stabilization wait time setting register | R/W | 11111111 <sub>B</sub> |
| 0006 <sub>H</sub>                        | PLLC                  | PLL control register                                 | R/W | 00000000 <sub>B</sub> |
| 0007 <sub>H</sub>                        | SYCC                  | System clock control register                        | R/W | 1010X011 <sub>B</sub> |
| 0008 <sub>H</sub>                        | STBC                  | Standby control register                             | R/W | 00000000 <sub>B</sub> |
| 0009 <sub>H</sub>                        | RSRR                  | Reset source register                                | R   | XXXXXXXX <sub>B</sub> |
| 000A <sub>H</sub>                        | TBTC                  | Timebase timer control register                      | R/W | 00000000 <sub>B</sub> |
| 000B <sub>H</sub>                        | WPCR                  | Watch prescaler control register                     | R/W | 00000000 <sub>B</sub> |
| 000C <sub>H</sub>                        | WDTC                  | Watchdog timer control register                      | R/W | 00000000 <sub>B</sub> |
| 000D <sub>H</sub>                        | —                     | (Disabled)   | —   | —                     |
| 000E <sub>H</sub>                        | PDR2                  | Port 2 data register                                 | R/W | 00000000 <sub>B</sub> |
| 000F <sub>H</sub>                        | DDR2                  | Port 2 direction register                            | R/W | 00000000 <sub>B</sub> |
| 0010 <sub>H</sub>                        | PDR3                  | Port 3 data register                                 | R/W | 00000000 <sub>B</sub> |
| 0011 <sub>H</sub>                        | DDR3                  | Port 3 direction register                            | R/W | 00000000 <sub>B</sub> |
| 0012 <sub>H</sub>                        | PDR4                  | Port 4 data register                                 | R/W | 00000000 <sub>B</sub> |
| 0013 <sub>H</sub>                        | DDR4                  | Port 4 direction register                            | R/W | 00000000 <sub>B</sub> |
| 0014 <sub>H</sub>                        | PDR5                  | Port 5 data register                                 | R/W | 00000000 <sub>B</sub> |
| 0015 <sub>H</sub>                        | DDR5                  | Port 5 direction register                            | R/W | 00000000 <sub>B</sub> |
| 0016 <sub>H</sub>                        | PDR6                  | Port 6 data register                                 | R/W | 00000000 <sub>B</sub> |
| 0017 <sub>H</sub>                        | DDR6                  | Port 6 direction register                            | R/W | 00000000 <sub>B</sub> |
| 0018 <sub>H</sub>                        | PDR7                  | Port 7 data register                                 | R/W | 00000000 <sub>B</sub> |
| 0019 <sub>H</sub>                        | DDR7                  | Port 7 direction register                            | R/W | 00000000 <sub>B</sub> |
| 001A <sub>H</sub> ,<br>001B <sub>H</sub> | —                     | (Disabled)   | —   | —                     |
| 001C <sub>H</sub>                        | PDR9                  | Port 9 data register                                 | R/W | 00000000 <sub>B</sub> |
| 001D <sub>H</sub>                        | DDR9                  | Port 9 direction register                            | R/W | 00000000 <sub>B</sub> |
| 001E <sub>H</sub>                        | PDRA                  | Port A data register                                 | R/W | 00000000 <sub>B</sub> |
| 001F <sub>H</sub>                        | DDRA                  | Port A direction register                            | R/W | 00000000 <sub>B</sub> |
| 0020 <sub>H</sub>                        | PDRB                  | Port B data register                                 | R/W | 00000000 <sub>B</sub> |
| 0021 <sub>H</sub>                        | DDRB                  | Port B direction register                            | R/W | 00000000 <sub>B</sub> |
| 0022 <sub>H</sub>                        | PDRC                  | Port C data register                                 | R/W | 00000000 <sub>B</sub> |

(Continued)

# MB95120H Series

| Address                                      | Register abbreviation | Register name   | R/W | Initial value         |
|--|-----------------------|---|-----|-----------------------|
| 0023 <sub>H</sub>                            | DDRC                  | Port C direction register                                     | R/W | 00000000 <sub>B</sub> |
| 0024 <sub>H</sub>                            | PDRD                  | Port D data register  | R/W | 00000000 <sub>B</sub> |
| 0025 <sub>H</sub>                            | DDRD                  | Port D direction register                                     | R/W | 00000000 <sub>B</sub> |
| 0026 <sub>H</sub>                            | PDRE                  | Port E data register  | R/W | 00000000 <sub>B</sub> |
| 0027 <sub>H</sub>                            | DDRE                  | Port E direction register                                     | R/W | 00000000 <sub>B</sub> |
| 0028 <sub>H</sub><br>to<br>002C <sub>H</sub> | —                     | (Disabled)  | —   | —                     |
| 002D <sub>H</sub>                            | PUL1                  | Port 1 pull-up register                                       | R/W | 00000000 <sub>B</sub> |
| 002E <sub>H</sub>                            | PUL2                  | Port 2 pull-up register                                       | R/W | 00000000 <sub>B</sub> |
| 002F <sub>H</sub>                            | PUL3                  | Port 3 pull-up register                                       | R/W | 00000000 <sub>B</sub> |
| 0030 <sub>H</sub>                            | PUL4                  | Port 4 pull-up register                                       | R/W | 00000000 <sub>B</sub> |
| 0031 <sub>H</sub>                            | PUL5                  | Port 5 pull-up register                                       | R/W | 00000000 <sub>B</sub> |
| 0032 <sub>H</sub>                            | PUL7                  | Port 7 pull-up register                                       | R/W | 00000000 <sub>B</sub> |
| 0033 <sub>H</sub><br>to<br>0035 <sub>H</sub> | —                     | (Disabled)  | —   | —                     |
| 0036 <sub>H</sub>                            | T01CR1                | 8/16-bit compound timer 01 control status register 1 ch.0     | R/W | 00000000 <sub>B</sub> |
| 0037 <sub>H</sub>                            | T00CR1                | 8/16-bit compound timer 00 control status register 1 ch.0     | R/W | 00000000 <sub>B</sub> |
| 0038 <sub>H</sub>                            | T11CR1                | 8/16-bit compound timer 11 control status register 1 ch.1     | R/W | 00000000 <sub>B</sub> |
| 0039 <sub>H</sub>                            | T10CR1                | 8/16-bit compound timer 10 control status register 1 ch.1     | R/W | 00000000 <sub>B</sub> |
| 003A <sub>H</sub>                            | PC01                  | 8/16-bit PPG1 control register ch.0                           | R/W | 00000000 <sub>B</sub> |
| 003B <sub>H</sub>                            | PC00                  | 8/16-bit PPG0 control register ch.0                           | R/W | 00000000 <sub>B</sub> |
| 003C <sub>H</sub>                            | PC11                  | 8/16-bit PPG1 control register ch.1                           | R/W | 00000000 <sub>B</sub> |
| 003D <sub>H</sub>                            | PC10                  | 8/16-bit PPG0 control register ch.1                           | R/W | 00000000 <sub>B</sub> |
| 003E <sub>H</sub>                            | TMCSRH0               | 16-bit reload timer control status register (upper byte) ch.0 | R/W | 00000000 <sub>B</sub> |
| 003F <sub>H</sub>                            | TMCSRL0               | 16-bit reload timer control status register (lower byte) ch.0 | R/W | 00000000 <sub>B</sub> |
| 0040 <sub>H</sub> ,<br>0041 <sub>H</sub>     | —                     | (Disabled)  | —   | —                     |
| 0042 <sub>H</sub>                            | PCNTH0                | 16-bit PPG status control register (upper byte) ch.0          | R/W | 00000000 <sub>B</sub> |
| 0043 <sub>H</sub>                            | PCNTL0                | 16-bit PPG status control register (lower byte) ch.0          | R/W | 00000000 <sub>B</sub> |
| 0044 <sub>H</sub>                            | PCNTH1                | 16-bit PPG status control register (upper byte) ch.1          | R/W | 00000000 <sub>B</sub> |
| 0045 <sub>H</sub>                            | PCNTL1                | 16-bit PPG status control register (lower byte) ch.1          | R/W | 00000000 <sub>B</sub> |
| 0046 <sub>H</sub> ,<br>0047 <sub>H</sub>     | —                     | (Disabled)  | —   | —                     |
| 0048 <sub>H</sub>                            | EIC00                 | External interrupt circuit control register ch.0/1            | R/W | 00000000 <sub>B</sub> |
| 0049 <sub>H</sub>                            | EIC10                 | External interrupt circuit control register ch.2/3            | R/W | 00000000 <sub>B</sub> |

(Continued)

# MB95120H Series

| Address                                      | Register abbreviation | Register name  | R/W | Initial value         |
|--|-----------------------|--|-----|-----------------------|
| 004A <sub>H</sub>                            | EIC20                 | External interrupt circuit control register ch.4/5   | R/W | 00000000 <sub>B</sub> |
| 004B <sub>H</sub>                            | EIC30                 | External interrupt circuit control register ch.6/7   | R/W | 00000000 <sub>B</sub> |
| 004C <sub>H</sub>                            | EIC01                 | External interrupt circuit control register ch.8/9   | R/W | 00000000 <sub>B</sub> |
| 004D <sub>H</sub>                            | EIC11                 | External interrupt circuit control register ch.10/11 | R/W | 00000000 <sub>B</sub> |
| 004E <sub>H</sub> ,<br>004F <sub>H</sub>     | —                     | (Disabled)   | —   | —                     |
| 0050 <sub>H</sub>                            | SCR                   | LIN-UART serial control register                     | R/W | 00000000 <sub>B</sub> |
| 0051 <sub>H</sub>                            | SMR                   | LIN-UART serial mode register                        | R/W | 00000000 <sub>B</sub> |
| 0052 <sub>H</sub>                            | SSR                   | LIN-UART serial status register                      | R/W | 00001000 <sub>B</sub> |
| 0053 <sub>H</sub>                            | RDR/TDR               | LIN-UART reception/transmission data register        | R/W | 00000000 <sub>B</sub> |
| 0054 <sub>H</sub>                            | ESCR                  | LIN-UART extended status control register            | R/W | 00000100 <sub>B</sub> |
| 0055 <sub>H</sub>                            | ECCR                  | LIN-UART extended communication control register     | R/W | 000000XX <sub>B</sub> |
| 0056 <sub>H</sub>                            | SMC10                 | UART/SIO serial mode control register 1 ch.0         | R/W | 00000000 <sub>B</sub> |
| 0057 <sub>H</sub>                            | SMC20                 | UART/SIO serial mode control register 2 ch.0         | R/W | 00100000 <sub>B</sub> |
| 0058 <sub>H</sub>                            | SSR0                  | UART/SIO serial status register ch.0                 | R/W | 00000001 <sub>B</sub> |
| 0059 <sub>H</sub>                            | TDR0                  | UART/SIO serial output data register ch.0            | R/W | 00000000 <sub>B</sub> |
| 005A <sub>H</sub>                            | RDR0                  | UART/SIO serial input data register ch.0             | R   | 00000000 <sub>B</sub> |
| 005B <sub>H</sub><br>to<br>005F <sub>H</sub> | —                     | (Disabled)   | —   | —                     |
| 0060 <sub>H</sub>                            | IBCR00                | I <sup>2</sup> C bus control register 0 ch.0         | R/W | 00000000 <sub>B</sub> |
| 0061 <sub>H</sub>                            | IBCR10                | I <sup>2</sup> C bus control register 1 ch.0         | R/W | 00000000 <sub>B</sub> |
| 0062 <sub>H</sub>                            | IBSR0                 | I <sup>2</sup> C bus status register ch.0            | R   | 00000000 <sub>B</sub> |
| 0063 <sub>H</sub>                            | IDDR0                 | I <sup>2</sup> C data register ch.0                  | R/W | 00000000 <sub>B</sub> |
| 0064 <sub>H</sub>                            | IAAR0                 | I <sup>2</sup> C address register ch.0               | R/W | 00000000 <sub>B</sub> |
| 0065 <sub>H</sub>                            | ICCR0                 | I <sup>2</sup> C clock control register ch.0         | R/W | 00000000 <sub>B</sub> |
| 0066 <sub>H</sub><br>to<br>006B <sub>H</sub> | —                     | (Disabled)   | —   | —                     |
| 006C <sub>H</sub>                            | ADC1                  | 8/10-bit A/D converter control register 1            | R/W | 00000000 <sub>B</sub> |
| 006D <sub>H</sub>                            | ADC2                  | 8/10-bit A/D converter control register 2            | R/W | 00000000 <sub>B</sub> |
| 006E <sub>H</sub>                            | ADDH                  | 8/10-bit A/D converter data register (upper byte)    | R/W | 00000000 <sub>B</sub> |
| 006F <sub>H</sub>                            | ADDL                  | 8/10-bit A/D converter data register (lower byte)    | R/W | 00000000 <sub>B</sub> |
| 0070 <sub>H</sub>                            | WCSR                  | Watch counter status register                        | R/W | 00000000 <sub>B</sub> |
| 0071 <sub>H</sub>                            | —                     | (Disabled)   | —   | —                     |
| 0072 <sub>H</sub>                            | FSR                   | Flash memory status register                         | R/W | 000X0000 <sub>B</sub> |

(Continued)

# MB95120H Series

| Address                                      | Register abbreviation | Register name  | R/W | Initial value         |
|--|-----------------------|--|-----|-----------------------|
| 0073 <sub>H</sub>                            | SWRE0                 | FLASH memory sector writing control register 0                     | R/W | 00000000 <sub>B</sub> |
| 0074 <sub>H</sub>                            | SWRE1                 | FLASH memory sector writing control register 1                     | R/W | 00000000 <sub>B</sub> |
| 0075 <sub>H</sub>                            | —                     | (Disabled)   | —   | —                     |
| 0076 <sub>H</sub>                            | WREN                  | Wild register address compare enable register                      | R/W | 00000000 <sub>B</sub> |
| 0077 <sub>H</sub>                            | WROR                  | Wild register data test setting register                           | R/W | 00000000 <sub>B</sub> |
| 0078 <sub>H</sub>                            | —                     | Register bank pointer (RP) ,<br>Mirror of direct bank pointer (DP) | —   | —                     |
| 0079 <sub>H</sub>                            | ILR0                  | Interrupt level setting register 0                                 | R/W | 11111111 <sub>B</sub> |
| 007A <sub>H</sub>                            | ILR1                  | Interrupt level setting register 1                                 | R/W | 11111111 <sub>B</sub> |
| 007B <sub>H</sub>                            | ILR2                  | Interrupt level setting register 2                                 | R/W | 11111111 <sub>B</sub> |
| 007C <sub>H</sub>                            | ILR3                  | Interrupt level setting register 3                                 | R/W | 11111111 <sub>B</sub> |
| 007D <sub>H</sub>                            | ILR4                  | Interrupt level setting register 4                                 | R/W | 11111111 <sub>B</sub> |
| 007E <sub>H</sub>                            | ILR5                  | Interrupt level setting register 5                                 | R/W | 11111111 <sub>B</sub> |
| 007F <sub>H</sub>                            | —                     | (Disabled)   | —   | —                     |
| 0F80 <sub>H</sub>                            | WRARH0                | Wild register address setting register (upper byte) ch.0           | R/W | 00000000 <sub>B</sub> |
| 0F81 <sub>H</sub>                            | WRARL0                | Wild register address setting register (lower byte) ch.0           | R/W | 00000000 <sub>B</sub> |
| 0F82 <sub>H</sub>                            | WRDR0                 | Wild register data setting register ch.0                           | R/W | 00000000 <sub>B</sub> |
| 0F83 <sub>H</sub>                            | WRARH1                | Wild register address setting register (upper byte) ch.1           | R/W | 00000000 <sub>B</sub> |
| 0F84 <sub>H</sub>                            | WRARL1                | Wild register address setting register (lower byte) ch.1           | R/W | 00000000 <sub>B</sub> |
| 0F85 <sub>H</sub>                            | WRDR1                 | Wild register data setting register ch.1                           | R/W | 00000000 <sub>B</sub> |
| 0F86 <sub>H</sub>                            | WRARH2                | Wild register address setting register (upper byte) ch.2           | R/W | 00000000 <sub>B</sub> |
| 0F87 <sub>H</sub>                            | WRARL2                | Wild register address setting register (lower byte) ch.2           | R/W | 00000000 <sub>B</sub> |
| 0F88 <sub>H</sub>                            | WRDR2                 | Wild register data setting register ch.2                           | R/W | 00000000 <sub>B</sub> |
| 0F89 <sub>H</sub><br>to<br>0F91 <sub>H</sub> | —                     | (Disabled)   | —   | —                     |
| 0F92 <sub>H</sub>                            | T01CR0                | 8/16-bit compound timer 01 control status register 0 ch.0          | R/W | 00000000 <sub>B</sub> |
| 0F93 <sub>H</sub>                            | T00CR0                | 8/16-bit compound timer 00 control status register 0 ch.0          | R/W | 00000000 <sub>B</sub> |
| 0F94 <sub>H</sub>                            | T01DR                 | 8/16-bit compound timer 01 data register ch.0                      | R/W | 00000000 <sub>B</sub> |
| 0F95 <sub>H</sub>                            | T00DR                 | 8/16-bit compound timer 00 data register ch.0                      | R/W | 00000000 <sub>B</sub> |
| 0F96 <sub>H</sub>                            | TMCR0                 | 8/16-bit compound timer 00/01 timer mode control register<br>ch.0  | R/W | 00000000 <sub>B</sub> |
| 0F97 <sub>H</sub>                            | T11CR0                | 8/16-bit compound timer 11 control status register 0 ch.1          | R/W | 00000000 <sub>B</sub> |
| 0F98 <sub>H</sub>                            | T10CR0                | 8/16-bit compound timer 10 control status register 0 ch.1          | R/W | 00000000 <sub>B</sub> |
| 0F99 <sub>H</sub>                            | T11DR                 | 8/16-bit compound timer 11 data register ch.1                      | R/W | 00000000 <sub>B</sub> |
| 0F9A <sub>H</sub>                            | T10DR                 | 8/16-bit compound timer 10 data register ch.1                      | R/W | 00000000 <sub>B</sub> |

(Continued)

# MB95120H Series

| Address                                      | Register abbreviation | Register name   | R/W | Initial value         |
|--|-----------------------|---|-----|-----------------------|
| 0F9B <sub>H</sub>                            | TMCR1                 | 8/16-bit compound timer 10/11 timer mode control register ch.1        | R/W | 00000000 <sub>B</sub> |
| 0F9C <sub>H</sub>                            | PPS01                 | 8/16-bit PPG1 cycle setting buffer register ch.0                      | R/W | 11111111 <sub>B</sub> |
| 0F9D <sub>H</sub>                            | PPS00                 | 8/16-bit PPG0 cycle setting buffer register ch.0                      | R/W | 11111111 <sub>B</sub> |
| 0F9E <sub>H</sub>                            | PDS01                 | 8/16-bit PPG1 duty setting buffer register ch.0                       | R/W | 11111111 <sub>B</sub> |
| 0F9F <sub>H</sub>                            | PDS00                 | 8/16-bit PPG0 duty setting buffer register ch.0                       | R/W | 11111111 <sub>B</sub> |
| 0FA0 <sub>H</sub>                            | PPS11                 | 8/16-bit PPG1 cycle setting buffer register ch.1                      | R/W | 11111111 <sub>B</sub> |
| 0FA1 <sub>H</sub>                            | PPS10                 | 8/16-bit PPG0 cycle setting buffer register ch.1                      | R/W | 11111111 <sub>B</sub> |
| 0FA2 <sub>H</sub>                            | PDS11                 | 8/16-bit PPG1 duty setting buffer register ch.1                       | R/W | 11111111 <sub>B</sub> |
| 0FA3 <sub>H</sub>                            | PDS10                 | 8/16-bit PPG0 duty setting buffer register ch.1                       | R/W | 11111111 <sub>B</sub> |
| 0FA4 <sub>H</sub>                            | PPGS                  | 8/16-bit PPG start register   | R/W | 00000000 <sub>B</sub> |
| 0FA5 <sub>H</sub>                            | REVC                  | 8/16-bit PPG output inversion register                                | R/W | 00000000 <sub>B</sub> |
| 0FA6 <sub>H</sub>                            | TMRH0/<br>TMRLRH0     | 16-bit reload timer timer/reload register (upper byte) ch.0           | R/W | 00000000 <sub>B</sub> |
| 0FA7 <sub>H</sub>                            | TMRL0/<br>TMRLRL0     | 16-bit reload timer timer/reload register (lower byte) ch.0           | R/W | 00000000 <sub>B</sub> |
| 0FA8 <sub>H</sub> ,<br>0FA9 <sub>H</sub>     | —                     | (Disabled)  | —   | —                     |
| 0FAA <sub>H</sub>                            | PDCRH0                | 16-bit PPG down counter register (upper byte) ch.0                    | R   | 00000000 <sub>B</sub> |
| 0FAB <sub>H</sub>                            | PDCRL0                | 16-bit PPG down counter register (lower byte) ch.0                    | R   | 00000000 <sub>B</sub> |
| 0FAC <sub>H</sub>                            | PCSRH0                | 16-bit PPG cycle setting buffer register (upper byte) ch.0            | R/W | 11111111 <sub>B</sub> |
| 0FAD <sub>H</sub>                            | PCSRL0                | 16-bit PPG cycle setting buffer register (lower byte) ch.0            | R/W | 11111111 <sub>B</sub> |
| 0FAE <sub>H</sub>                            | PDUTH0                | 16-bit PPG duty setting buffer register (upper byte) ch.0             | R/W | 11111111 <sub>B</sub> |
| 0FAF <sub>H</sub>                            | PDUTL0                | 16-bit PPG duty setting buffer register (lower byte) ch.0             | R/W | 11111111 <sub>B</sub> |
| 0FB0 <sub>H</sub>                            | PDCRH1                | 16-bit PPG down counter register (upper byte) ch.1                    | R   | 00000000 <sub>B</sub> |
| 0FB1 <sub>H</sub>                            | PDCRL1                | 16-bit PPG down counter register (lower byte) ch.1                    | R   | 00000000 <sub>B</sub> |
| 0FB2 <sub>H</sub>                            | PCSRH1                | 16-bit PPG cycle setting buffer register (upper byte) ch.1            | R/W | 11111111 <sub>B</sub> |
| 0FB3 <sub>H</sub>                            | PCSRL1                | 16-bit PPG cycle setting buffer register (lower byte) ch.1            | R/W | 11111111 <sub>B</sub> |
| 0FB4 <sub>H</sub>                            | PDUTH1                | 16-bit PPG duty setting buffer register (upper byte) ch.1             | R/W | 11111111 <sub>B</sub> |
| 0FB5 <sub>H</sub>                            | PDUTL1                | 16-bit PPG duty setting buffer register (lower byte) ch.1             | R/W | 11111111 <sub>B</sub> |
| 0FB6 <sub>H</sub><br>to<br>0FBB <sub>H</sub> | —                     | (Disabled)  | —   | —                     |
| 0FBC <sub>H</sub>                            | BGR1                  | LIN-UART baud rate generator register 1                               | R/W | 00000000 <sub>B</sub> |
| 0FBD <sub>H</sub>                            | BGR0                  | LIN-UART baud rate generator register 0                               | R/W | 00000000 <sub>B</sub> |
| 0FBE <sub>H</sub>                            | PSSR0                 | UART/SIO dedicated baud rate generator prescaler select register ch.0 | R/W | 00000000 <sub>B</sub> |

(Continued)

(Continued)

| Address                                      | Register abbreviation | Register name   | R/W | Initial value         |
|--|-----------------------|---|-----|-----------------------|
| 0FBFH  | BRSR0                 | UART/SIO dedicated baud rate generator<br>baud rate setting register ch.0 | R/W | 00000000 <sub>B</sub> |
| 0FC0H,<br>0FC1H                              | —                     | (Disabled)  | —   | —                     |
| 0FC2H  | AIDRH                 | A/D input disable register (upper byte)                                   | R/W | 00000000 <sub>B</sub> |
| 0FC3H  | AIDRL                 | A/D input disable register (lower byte)                                   | R/W | 00000000 <sub>B</sub> |
| 0FC4H  | LCDCC                 | LCDC control register   | R/W | 00010000 <sub>B</sub> |
| 0FC5H  | LCDCE1                | LCDC enable register 1  | R/W | 00110000 <sub>B</sub> |
| 0FC6H  | LCDCE2                | LCDC enable register 2  | R/W | 00000000 <sub>B</sub> |
| 0FC7H  | LCDCE3                | LCDC enable register 3  | R/W | 00000000 <sub>B</sub> |
| 0FC8H  | LCDCE4                | LCDC enable register 4  | R/W | 00000000 <sub>B</sub> |
| 0FC9H  | LCDCE5                | LCDC enable register 5  | R/W | 00000000 <sub>B</sub> |
| 0FCAH  | LCDCE6                | LCDC enable register 6  | R/W | 00000000 <sub>B</sub> |
| 0FCBH  | LCDCB1                | LCDC blinking setting register 1  | R/W | 00000000 <sub>B</sub> |
| 0FCC <sub>H</sub>                            | LCDCB2                | LCDC blinking setting register 2  | R/W | 00000000 <sub>B</sub> |
| 0FCD <sub>H</sub><br>to<br>0FE0 <sub>H</sub> | LCDRAM                | LCDC display RAM  | R/W | 00000000 <sub>B</sub> |
| 0FE1 <sub>H</sub> ,<br>0FE2 <sub>H</sub>     | —                     | (Disabled)  | —   | —                     |
| 0FE3 <sub>H</sub>                            | WCDR                  | Watch counter data register   | R/W | 00111111 <sub>B</sub> |
| 0FE4 <sub>H</sub><br>to<br>0FED <sub>H</sub> | —                     | (Disabled)  | —   | —                     |
| 0FEE <sub>H</sub>                            | ILSR                  | Input level select register   | R/W | 00000000 <sub>B</sub> |
| 0FEF <sub>H</sub>                            | WICR                  | Interrupt pin select circuit control register                             | R/W | 01000000 <sub>B</sub> |
| 0FF0 <sub>H</sub><br>to<br>0FFF <sub>H</sub> | —                     | (Disabled)  | —   | —                     |

- R/W access symbols

R/W : Readable/Writable

R : Read only

W : Write only

- Initial value symbols

0 : The initial value of this bit is "0".

1 : The initial value of this bit is "1".

X : The initial value of this bit is undefined.

Note : Do not write to the "(Disabled)". Reading the "(Disabled)" returns an undefined value.

# MB95120H Series

## ■ INTERRUPT SOURCE TABLE

| Interrupt source                     | Interrupt request number | Vector table address |                   | Bit name of interrupt level setting register | Same level priority order (at simultaneous occurrence)                                 |
|--------------------------------------|--------------------------|----------------------|-------------------|--|--|
|                                      |                          | Upper                | Lower             |  |  |
| External interrupt ch.0              | IRQ0                     | FFFA <sub>H</sub>    | FFFB <sub>H</sub> | L00 [1 : 0]                                  | <div style="text-align: center;">High</div> <div style="text-align: center;">Low</div> |
| External interrupt ch.4              |                          |                      |                   |  |  |
| External interrupt ch.1              | IRQ1                     | FFF8 <sub>H</sub>    | FFF9 <sub>H</sub> | L01 [1 : 0]                                  |  |
| External interrupt ch.5              |                          |                      |                   |  |  |
| External interrupt ch.2              | IRQ2                     | FFF6 <sub>H</sub>    | FFF7 <sub>H</sub> | L02 [1 : 0]                                  |  |
| External interrupt ch.6              |                          |                      |                   |  |  |
| External interrupt ch.3              | IRQ3                     | FFF4 <sub>H</sub>    | FFF5 <sub>H</sub> | L03 [1 : 0]                                  |  |
| External interrupt ch.7              |                          |                      |                   |  |  |
| UART/SIO ch.0                        | IRQ4                     | FFF2 <sub>H</sub>    | FFF3 <sub>H</sub> | L04 [1 : 0]                                  |  |
| 8/16-bit compound timer ch.0 (Lower) | IRQ5                     | FFF0 <sub>H</sub>    | FFF1 <sub>H</sub> | L05 [1 : 0]                                  |  |
| 8/16-bit compound timer ch.0 (Upper) | IRQ6                     | FFEE <sub>H</sub>    | FFEF <sub>H</sub> | L06 [1 : 0]                                  |  |
| LIN-UART (reception)                 | IRQ7                     | FFEC <sub>H</sub>    | FFED <sub>H</sub> | L07 [1 : 0]                                  |  |
| LIN-UART (transmission)              | IRQ8                     | FFEA <sub>H</sub>    | FFEB <sub>H</sub> | L08 [1 : 0]                                  |  |
| 8/16-bit PPG ch.1 (Lower)            | IRQ9                     | FFE8 <sub>H</sub>    | FFE9 <sub>H</sub> | L09 [1 : 0]                                  |  |
| 8/16-bit PPG ch.1 (Upper)            | IRQ10                    | FFE6 <sub>H</sub>    | FFE7 <sub>H</sub> | L10 [1 : 0]                                  |  |
| 16-bit reload timer ch.0             | IRQ11                    | FFE4 <sub>H</sub>    | FFE5 <sub>H</sub> | L11 [1 : 0]                                  |  |
| 8/16-bit PPG ch.0 (Upper)            | IRQ12                    | FFE2 <sub>H</sub>    | FFE3 <sub>H</sub> | L12 [1 : 0]                                  |  |
| 8/16-bit PPG ch.0 (Lower)            | IRQ13                    | FFE0 <sub>H</sub>    | FFE1 <sub>H</sub> | L13 [1 : 0]                                  |  |
| 8/16-bit compound timer ch.1 (Upper) | IRQ14                    | FFDE <sub>H</sub>    | FFDF <sub>H</sub> | L14 [1 : 0]                                  |  |
| 16-bit PPG ch.0                      | IRQ15                    | FFDC <sub>H</sub>    | FFDD <sub>H</sub> | L15 [1 : 0]                                  |  |
| I <sup>2</sup> C ch.0                | IRQ16                    | FFDA <sub>H</sub>    | FFDB <sub>H</sub> | L16 [1 : 0]                                  |  |
| 16-bit PPG ch.1                      | IRQ17                    | FFD8 <sub>H</sub>    | FFD9 <sub>H</sub> | L17 [1 : 0]                                  |  |
| 8/10-bit A/D converter               | IRQ18                    | FFD6 <sub>H</sub>    | FFD7 <sub>H</sub> | L18 [1 : 0]                                  |  |
| Timebase timer                       | IRQ19                    | FFD4 <sub>H</sub>    | FFD5 <sub>H</sub> | L19 [1 : 0]                                  |  |
| Watch timer/counter                  | IRQ20                    | FFD2 <sub>H</sub>    | FFD3 <sub>H</sub> | L20 [1 : 0]                                  |  |
| External interrupt ch.8              | IRQ21                    | FFD0 <sub>H</sub>    | FFD1 <sub>H</sub> | L21 [1 : 0]                                  |  |
| External interrupt ch.9              |                          |                      |                   |  |  |
| External interrupt ch.10             |                          |                      |                   |  |  |
| External interrupt ch.11             |                          |                      |                   |  |  |
| 8/16-bit compound timer ch.1 (Lower) | IRQ22                    | FFCE <sub>H</sub>    | FFCF <sub>H</sub> | L22 [1 : 0]                                  |  |
| Flash memory                         | IRQ23                    | FFCC <sub>H</sub>    | FFCD <sub>H</sub> | L23 [1 : 0]                                  |  |

## ■ ELECTRICAL CHARACTERISTICS

### 1. Absolute Maximum Ratings

| Parameter                              | Symbol                              | Rating                |                       | Unit | Remarks   |
|--|-------------------------------------|-----------------------|-----------------------|------|---|
|  |                                     | Min                   | Max                   |      |   |
| Power supply voltage*1                 | V <sub>CC</sub><br>AV <sub>CC</sub> | V <sub>SS</sub> - 0.3 | V <sub>SS</sub> + 6.0 | V    | *2  |
|  | AVR                                 | V <sub>SS</sub> - 0.3 | V <sub>SS</sub> + 6.0 |      | *2  |
| Power supply voltage for LCD           | V <sub>0</sub> to V <sub>3</sub>    | V <sub>SS</sub> - 0.3 | V <sub>SS</sub> + 6.0 | V    | *3  |
| Input voltage*1                        | V <sub>I</sub>                      | V <sub>SS</sub> - 0.3 | V <sub>SS</sub> + 6.0 | V    | *4  |
| Output voltage*1                       | V <sub>O</sub>                      | V <sub>SS</sub> - 0.3 | V <sub>SS</sub> + 6.0 | V    | *4  |
| Maximum clamp current                  | I <sub>CLAMP</sub>                  | - 2.0                 | + 2.0                 | mA   | Applicable to pins*5  |
| Total maximum clamp current            | Σ I <sub>CLAMP</sub>                | —                     | 20                    | mA   | Applicable to pins*5  |
| “L” level maximum output current       | I <sub>OL1</sub>                    | —                     | 15                    | mA   | Other than P00 to P07   |
|  | I <sub>OL2</sub>                    |                       | 15                    |      | P00 to P07  |
| “L” level average current              | I <sub>OLAV1</sub>                  | —                     | 4                     | mA   | Other than P00 to P07<br>Average output current =<br>operating current × operating ratio<br>(1 pin) |
|  | I <sub>OLAV2</sub>                  |                       | 12                    |      | P00 to P07<br>Average output current =<br>operating current × operating ratio<br>(1 pin)            |
| “L” level total maximum output current | ΣI <sub>OL</sub>                    | —                     | 100                   | mA   |   |
| “L” level total average output current | ΣI <sub>OLAV</sub>                  | —                     | 50                    | mA   | Total average output current =<br>operating current × operating ratio<br>(Total of pins)            |
| “H” level maximum output current       | I <sub>OH1</sub>                    | —                     | - 15                  | mA   | Other than P00 to P07   |
|  | I <sub>OH2</sub>                    |                       | - 15                  |      | P00 to P07  |
| “H” level average current              | I <sub>OHAV1</sub>                  | —                     | - 4                   | mA   | Other than P00 to P07<br>Average output current =<br>operating current × operating ratio<br>(1 pin) |
|  | I <sub>OHAV2</sub>                  |                       | - 8                   |      | P00 to P07<br>Average output current =<br>operating current × operating ratio<br>(1 pin)            |
| “H” level total maximum output current | ΣI <sub>OH</sub>                    | —                     | - 100                 | mA   |   |
| “H” level total average output current | ΣI <sub>OHAV</sub>                  | —                     | - 50                  | mA   | Total average output current =<br>operating current × operating ratio<br>(Total of pins)            |

(Continued)

# MB95120H Series

(Continued)

| Parameter             | Symbol           | Rating |       | Unit | Remarks |
|-----------------------|------------------|--------|-------|------|---------|
|                       |                  | Min    | Max   |      |         |
| Power consumption     | Pd               | —      | 320   | mW   |         |
| Operating temperature | T <sub>A</sub>   | - 40   | + 85  | °C   |         |
| Storage temperature   | T <sub>stg</sub> | - 55   | + 150 | °C   |         |

\*1 : The parameter is based on AV<sub>ss</sub> = V<sub>ss</sub> = 0.0 V.

\*2 : Apply equal potential to AV<sub>cc</sub> and V<sub>cc</sub>. AVR should not exceed AV<sub>cc</sub> + 0.3 V.

\*3 : V<sub>0</sub> to V<sub>3</sub> should not exceed V<sub>cc</sub> + 0.3 V.

\*4 : V<sub>i</sub> and V<sub>o</sub> should not exceed V<sub>cc</sub> + 0.3 V. V<sub>i</sub> must not exceed the rating voltage. However, if the maximum current to/from an input is limited by some means with external components, the I<sub>CLAMP</sub> rating supersedes the V<sub>i</sub> rating.

\*5 : Applicable to pins : P00 to P07, P10 to P14, P20 to P24, P30 to P37, P40 to P43, P52, P53

- Use within recommended operating conditions.
- Use at DC voltage (current).
- +B signal is an input signal that exceeds V<sub>cc</sub> voltage. The + B signal should always be applied a limiting resistance placed between the + B signal and the microcontroller.
- The value of the limiting resistance should be set so that when the + B signal is applied the input current to the microcontroller pin does not exceed rated values, either instantaneously or for prolonged periods.
- Note that when the microcontroller drive current is low, such as in the power saving modes, the +B input potential may pass through the protective diode and increase the potential at the V<sub>cc</sub> pin, and this affects other devices.
- Note that if the + B signal is inputted when the microcontroller power supply is off (not fixed at 0 V), the power supply is provided from the pins, so that incomplete operation may result.
- Note that if the + B input is applied during power-on, the power supply is provided from the pins and the resulting power supply voltage may not be sufficient to operate the power-on reset.
- Care must be taken not to leave the + B input pin open.
- Note that analog system input/output pins other than the A/D input pins (LCD drive pins, etc.) cannot accept +B signal input.
- Sample recommended circuits :

• Input/Output Equivalent circuits

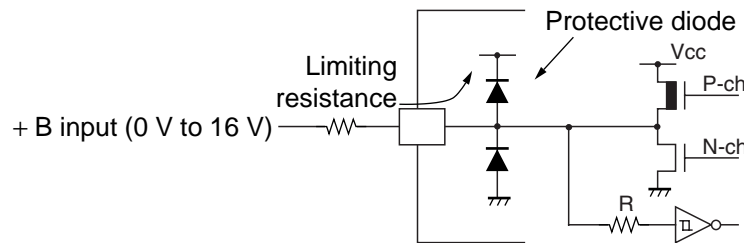

**WARNING:** Semiconductor devices can be permanently damaged by application of stress (voltage, current, temperature, etc.) in excess of absolute maximum ratings. Do not exceed these ratings.

# MB95120H Series

## 2. Recommended Operating Conditions

( $V_{SS} = V_{SS} = 0.0\text{ V}$ )

| Parameter                    | Symbol            | Pin name   | Condition | Value          |                | Unit | Remarks  |                        |
|------------------------------|-------------------|--|-----------|----------------|----------------|------|--|------------------------|
|                              |                   |  |           | Min            | Max            |      |  |                        |
| Power supply voltage         | $V_{CC}, AV_{CC}$ | —  | —         | 2.5*1,*2       | 5.5*1          | V    | In normal operating  | MB95F128H<br>MB95F128T |
|                              |                   | —  | —         | 2.3            | 5.5            |      | Hold condition in STOP mode  |                        |
|                              |                   | —  | —         | 2.7            | 5.5            |      | In normal operating  | MB95FV100B-103         |
|                              |                   | —  | —         | 2.3            | 5.5            |      | Hold condition in STOP mode  |                        |
| Power supply voltage for LCD | $V_0$ to $V_3$    | —  | —         | $V_{SS}$       | $V_{CC}$       | V    | The range of liquid crystal power supply: without up-conversion (The optimal value depends on liquid crystal display elements used.) |                        |
| "H" level input voltage      | $V_{IH1}$         | P10 (selectable at UI), P67 (selectable at SIN)  | —         | $0.7 V_{CC}$   | $V_{CC} + 0.3$ | V    | Hysteresis input (When selecting CMOS input level)   |                        |
|                              | $V_{IH2}$         | P50, P51 (selectable at I <sup>2</sup> C)  | —         | $0.7 V_{CC}$   | $V_{SS} + 5.5$ | V    |  |                        |
|                              | $V_{IHS1}$        | P00 to P07, P10 to P14, P20 to P24, P30 to P37, P40 to P43, P52, P53, P60 to P67, P70, P71, P90 to P95, PA0 to PA3, PB0 to PB7, PC0 to PC7, PD0 to PD7, PE0 to PE7 | —         | $0.8 V_{CC}$   | $V_{CC} + 0.3$ | V    | Hysteresis input   |                        |
|                              | $V_{IHS2}$        | P50, P51   | —         | $0.8 V_{CC}$   | $V_{SS} + 5.5$ | V    |  |                        |
|                              | $V_{IHM}$         | RST, MOD   | —         | $0.8 V_{CC}$   | $V_{CC} + 0.3$ | V    | Hysteresis input   |                        |
| "L" level input voltage      | $V_{IL}$          | P10 (selectable at UI), P50, P51 (selectable at I <sup>2</sup> C) P67 (selectable at SIN)  | —         | $V_{SS} - 0.3$ | $0.3 V_{CC}$   | V    | Hysteresis input (When selecting CMOS input level)   |                        |

(Continued)

# MB95120H Series

(Continued)

| Parameter                             | Symbol    | Pin name  | Condition | Value          |              | Unit        | Remarks              |
|---------------------------------------|-----------|---|-----------|----------------|--------------|-------------|----------------------|
|                                       |           |   |           | Min            | Max          |             |                      |
| “L” level input voltage               | $V_{ILS}$ | P00 to P07,<br>P10 to P14,<br>P20 to P24,<br>P30 to P37,<br>P40 to P43,<br>P50 to P53,<br>P60 to P67,<br>P70, P71,<br>P90 to P95,<br>PA0 to PA3,<br>PB0 to PB7,<br>PC0 to PC7,<br>PD0 to PD7,<br>PE0 to PE7 | —         | $V_{SS} - 0.3$ | $0.2 V_{CC}$ | V           | Hysteresis input     |
|                                       | $V_{ILM}$ | $\overline{RST}$ , MOD  | —         | $V_{SS} - 0.3$ | $0.2 V_{CC}$ | V           | Hysteresis input     |
| A/D converter reference input voltage | AVR       | —   | —         | 4.0            | $AV_{CC}$    | V           |                      |
| Smoothing capacitor                   | $C_s$     | —   | —         | 0.1            | 1.0          | $\mu F$     | *3                   |
| Operating temperature                 | $T_A$     | —   | —         | - 40           | + 85         | $^{\circ}C$ | MB95F128H, MB95F128T |
|                                       |           |   |           | + 5            | + 35         | $^{\circ}C$ | MB95FV100B-103       |

\*1 : The values vary with the operating frequency, machine clock or analog guarantee range.

\*2 : The value is 2.9 V when the low voltage detection reset is used.

\*3 : Use a ceramic capacitor or a capacitor with equivalent frequency characteristics. A bypass capacitor of  $V_{CC}$  pin must have a capacitor value higher than  $C_s$ . For connection of smoothing capacitor  $C_s$ , see the diagram below.

- C pin connection diagram

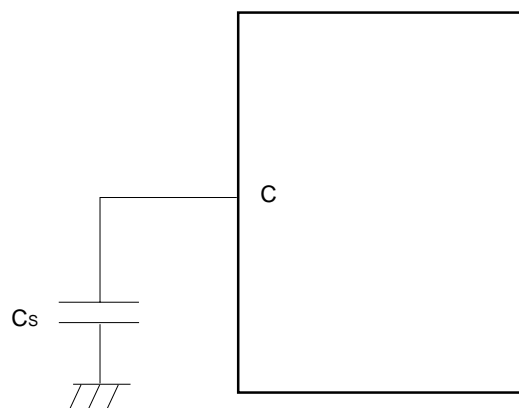

**WARNING:** The recommended operating conditions are required in order to ensure the normal operation of the semiconductor device. All of the device's electrical characteristics are warranted when the device is operated within these ranges.

Always use semiconductor devices within their recommended operating condition ranges. Operation outside these ranges may adversely affect reliability and could result in device failure.

No warranty is made with respect to uses, operating conditions, or combinations not represented on the data sheet. Users considering application outside the listed conditions are advised to contact their FUJITSU representatives beforehand.

# MB95120H Series

## 3. DC Characteristics

( $V_{CC} = AV_{CC} = 5.0\text{ V} \pm 10\%$ ,  $AV_{SS} = V_{SS} = 0.0\text{ V}$ ,  $T_A = -40\text{ }^\circ\text{C}$  to  $+85\text{ }^\circ\text{C}$ )

| Parameter   | Symbol     | Pin name   | Conditions  | Value          |      |                | Unit             | Remarks  |
|---|------------|--|---|----------------|------|----------------|------------------|--|
|   |            |  |   | Min            | Typ  | Max            |                  |  |
| “H” level output voltage                            | $V_{OH1}$  | Output pin other than P00 to P07                                   | $I_{OH} = -4.0\text{ mA}$   | 4.0            | —    | —              | V                |  |
|   | $V_{OH2}$  | P00 to P07   | $I_{OH} = -8.0\text{ mA}$   | 4.0            | —    | —              | V                |  |
| “L” level output voltage                            | $V_{OL1}$  | Output pin other than P00 to P07, $\overline{RST}$                 | $I_{OL} = 4.0\text{ mA}$  | —              | —    | 0.4            | V                |  |
|   | $V_{OL2}$  | P00 to P07   | $I_{OL} = 12\text{ mA}$   | —              | —    | 0.4            | V                |  |
| Open-drain output application voltage               | $V_{D1}$   | P50, P51   | —   | $V_{SS} - 0.3$ | —    | $V_{SS} + 5.5$ | V                |  |
| Input leakage current (Hi-Z output leakage current) | $I_{LI}$   | Port other than P50, P51   | $0.0\text{ V} < V_I < V_{CC}$   | -5             | —    | +5             | $\mu\text{A}$    | When the pull-up prohibition setting           |
| Open-drain output leakage current                   | $I_{LIOD}$ | P50, P51, P72, P73, P80 to P83                                     | $0.0\text{ V} < V_I < V_{SS} + 5.5\text{ V}$  | —              | —    | 5              | $\mu\text{A}$    |  |
| Pull-up resistor                                    | $R_{PULL}$ | P10 to P14, P20 to P24, P30 to P37, P40 to P43, P52, P53, P70, P71 | $V_I = 0.0\text{ V}$  | 25             | 50   | 100            | $\text{k}\Omega$ | When the pull-up permission setting            |
| Input capacitance                                   | $C_{IN}$   | Other than $AV_{CC}$ , $AV_{SS}$ , AVR, $V_{CC}$ , $V_{SS}$        | $f = 1\text{ MHz}$  | —              | 5    | 15             | pF               |  |
| Power supply current*                               | $I_{CC}$   | $V_{CC}$<br>(External clock operation)                             | $F_{CH} = 20\text{ MHz}$<br>$F_{MP} = 10\text{ MHz}$<br>Main clock mode<br>(divided by 2) | —              | 9.5  | 12.5           | mA               | At other than Flash memory writing and erasing |
|   |            |  | $F_{CH} = 20\text{ MHz}$<br>$F_{MP} = 10\text{ MHz}$<br>Main Sleep mode<br>(divided by 2) | —              | 30.0 | 35.0           | mA               | At Flash memory writing and erasing            |
|   | $I_{CCS}$  |  | $F_{CH} = 20\text{ MHz}$<br>$F_{MP} = 10\text{ MHz}$<br>Main Sleep mode<br>(divided by 2) | —              | 4.5  | 7.5            | mA               |  |

(Continued)

# MB95120H Series

( $V_{CC} = AV_{CC} = 5.0 \text{ V} \pm 10\%$ ,  $AV_{SS} = V_{SS} = 0.0 \text{ V}$ ,  $T_A = -40 \text{ }^\circ\text{C}$  to  $+85 \text{ }^\circ\text{C}$ )

| Parameter                        | Symbol              | Pin name                                      | Conditions  | Value |      |      | Unit | Remarks |
|----------------------------------|---------------------|---|---|-------|------|------|------|---------|
|                                  |                     |   |   | Min   | Typ  | Max  |      |         |
| Power supply current*            | I <sub>CCL</sub>    | V <sub>CC</sub><br>(External clock operation) | F <sub>CL</sub> = 32 kHz<br>F <sub>MPL</sub> = 16 kHz<br>sub clock mode<br>(divided by 2)                               | —     | 45   | 100  | μA   |         |
|                                  | I <sub>CCLS</sub>   |   | F <sub>CL</sub> = 32 kHz<br>F <sub>MPL</sub> = 16 kHz<br>Sub sleep mode<br>(divided by 2)                               | —     | 10   | 81   | μA   |         |
|                                  | I <sub>CCT</sub>    |   | F <sub>CL</sub> = 32 kHz<br>Watch mode<br>Main stop mode<br>T <sub>A</sub> = +25 °C                                     | —     | 4.6  | 27.0 | μA   |         |
|                                  | I <sub>CCMPLL</sub> |   | F <sub>CH</sub> = 4 MHz<br>F <sub>MP</sub> = 10 MHz<br>Main PLL mode<br>(multiplied by 2.5)                             | —     | 9.3  | 12.5 | mA   |         |
|                                  | I <sub>CCSPLL</sub> |   | F <sub>CL</sub> = 32 kHz<br>F <sub>MPL</sub> = 128 kHz<br>Sub PLL mode<br>(multiplied by 4),<br>T <sub>A</sub> = +25 °C | —     | 160  | 400  | μA   |         |
|                                  | I <sub>CTS</sub>    |   | F <sub>CH</sub> = 10 MHz<br>Timebase timer<br>mode<br>T <sub>A</sub> = +25 °C   | —     | 0.40 | 1.10 | mA   |         |
|                                  | I <sub>CCH</sub>    |   | Sub stop mode<br>T <sub>A</sub> = +25 °C  | —     | 3.5  | 20   | μA   |         |
|                                  | I <sub>A</sub>      | AV <sub>CC</sub>                              | F <sub>CH</sub> = 10 MHz<br>At operating of A/D<br>conversion   | —     | 2.4  | 4.7  | mA   |         |
|                                  | I <sub>AH</sub>     |   | F <sub>CH</sub> = 10 MHz<br>At stopping of A/D<br>conversion<br>T <sub>A</sub> = +25 °C                                 | —     | 1    | 5    | μA   |         |
| LCD internal division resistance | R <sub>LCD</sub>    | —   | Between V <sub>3</sub> and V <sub>SS</sub>  | —     | 300  | —    | kΩ   |         |
| COM0 to COM3 output impedance    | R <sub>VCOM</sub>   | COM0 to COM3                                  | V1 to V3 = 3.6 V  | —     | —    | 5    | kΩ   |         |

(Continued)

# MB95120H Series

(Continued)

( $V_{CC} = AV_{CC} = 5.0\text{ V}$ ,  $AV_{SS} = V_{SS} = 0.0\text{ V}$ ,  $T_A = -40\text{ }^\circ\text{C}$  to  $+85\text{ }^\circ\text{C}$ )

| Parameter                       | Symbol     | Pin name                                    | Conditions | Value |     |     | Unit          | Remarks |
|---------------------------------|------------|---|------------|-------|-----|-----|---------------|---------|
|                                 |            |   |            | Min   | Typ | Max |               |         |
| SEG00 to SEG39 output impedance | $R_{VSEG}$ | SEG00 to SEG39                              | —          | —     | —   | 7   | k $\Omega$    |         |
| LCD leak current                | $I_{LCDL}$ | V0 to V3,<br>COM0 to COM3<br>SEG00 to SEG39 | —          | -1    | —   | +1  | $\mu\text{A}$ |         |

- \* :
- The power-supply current is determined by the external clock. When both low voltage detection option is selected, the power-supply current will be a value of adding current consumption of the low voltage detection circuit ( $I_{LVD}$ ) to the specified value.
  - Refer to "4. AC characteristics (1) Clock Timing" for  $F_{CH}$  and  $F_{CL}$ .
  - Refer to "4. AC characteristics (2) Source Clock/Machine Clock" for  $F_{MP}$  and  $F_{MPL}$ .

# MB95120H Series

## 4. AC Characteristics

### (1) Clock Timing

( $V_{CC} = 2.5\text{ V to } 5.5\text{ V}$ ,  $AV_{SS} = V_{SS} = 0.0\text{ V}$ ,  $T_A = -40\text{ }^\circ\text{C to } +85\text{ }^\circ\text{C}$ )

| Parameter                           | Sym-<br>bol                          | Pin name | Condi-<br>tions | Value  |        |     | Unit   | Remarks                             |
|-------------------------------------|--------------------------------------|----------|-----------------|--------|--------|-----|--|-------------------------------------|
|                                     |                                      |          |                 | Min    | Typ    | Max |  |                                     |
| Clock frequency                     | F <sub>CH</sub>                      | X0, X1   | —               | 1      | —      | 10  | MHz  | When using main oscillation circuit |
|                                     |                                      |          |                 | 1      | —      | 20  | MHz  | When using external clock           |
|                                     |                                      |          |                 | 3      | —      | 10  | MHz  | Main PLL multiplied by 1            |
|                                     |                                      |          |                 | 3      | —      | 5   | MHz  | Main PLL multiplied by 2            |
|                                     |                                      |          |                 | 3      | —      | 4   | MHz  | Main PLL multiplied by 2.5          |
|                                     | F <sub>CL</sub>                      | X0A, X1A |                 | —      | 32.768 | —   | kHz  | When using sub oscillation circuit  |
|                                     |                                      |          | —               | 32.768 | —      | kHz | When using sub PLL<br>$V_{CC} = 2.3\text{ V to } 3.6\text{ V}$ |                                     |
| Clock cycle time                    | t <sub>H CYL</sub>                   | X0, X1   | 100             | —      | 1000   | ns  | When using main oscillation circuit                            |                                     |
|                                     |                                      |          | 50              | —      | 1000   | ns  | When using external clock                                      |                                     |
|                                     | t <sub>L CYL</sub>                   | X0A, X1A | —               | 30.5   | —      | μs  | When using sub oscillation circuit                             |                                     |
| Input clock pulse width             | t <sub>WH1</sub><br>t <sub>WL1</sub> | X0       | 10              | —      | —      | ns  | When using external clock<br>Duty ratio is about 30% to 70%.   |                                     |
|                                     | t <sub>WH2</sub><br>t <sub>WL2</sub> | X0A      | —               | 15.2   | —      | μs  |  |                                     |
| Input clock rise time and fall time | t <sub>CR</sub><br>t <sub>CF</sub>   | X0, X0A  | —               | —      | 5      | ns  | When using external clock                                      |                                     |

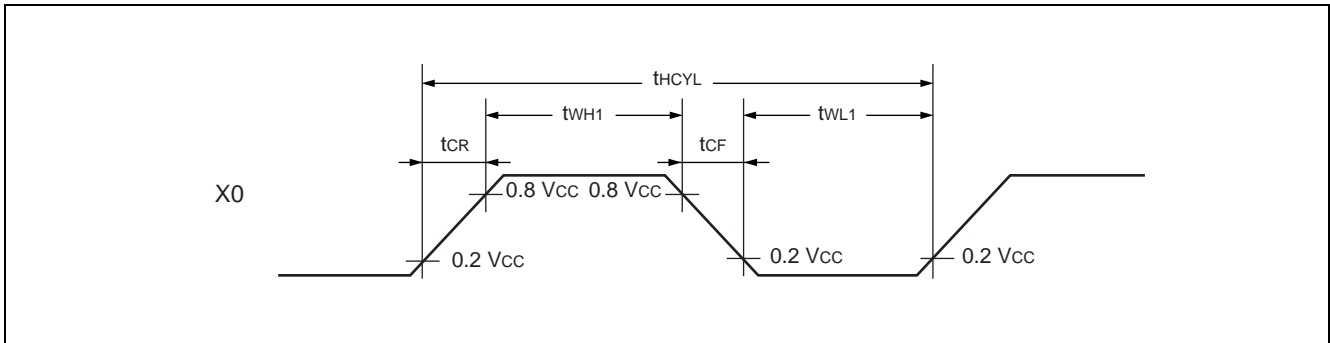

• Figure of Main Clock Input Port External Connection

When using a crystal or ceramic oscillator

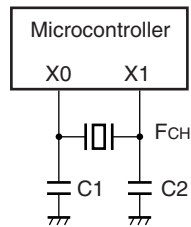

When using external clock

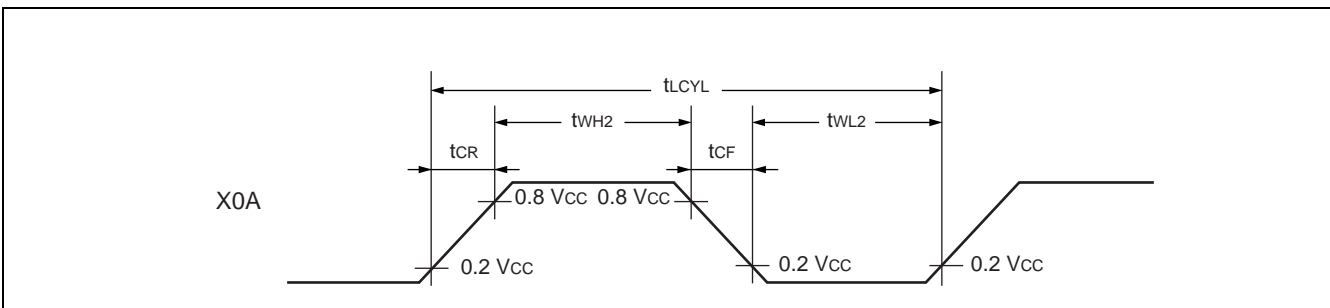
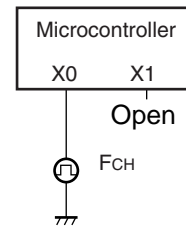

• Figure of Sub clock Input Port External Connection

When using a crystal or ceramic oscillator

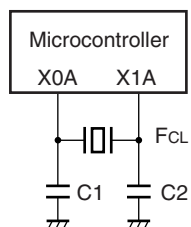

When using external clock

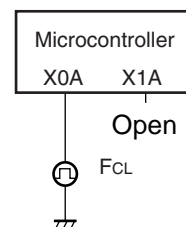

# MB95120H Series

## (2) Source Clock/Machine Clock

( $V_{CC} = 5.0\text{ V} \pm 10\%$ ,  $AV_{SS} = V_{SS} = 0.0\text{ V}$ ,  $T_A = -40\text{ }^\circ\text{C}$  to  $+85\text{ }^\circ\text{C}$ )

| Parameter  | Symbol     | Pin name | Value  |     |         | Unit          | Remarks   |
|--|------------|----------|--------|-----|---------|---------------|---|
|  |            |          | Min    | Typ | Max     |               |   |
| Source clock cycle time*1<br>(Clock before setting division)       | $t_{SCLK}$ | —        | 100    | —   | 2000    | ns            | When using main clock<br>Min : $F_{CH} = 10\text{ MHz}$ , PLL multiplied by 1<br>Max : $F_{CH} = 1\text{ MHz}$ , divided by 2 |
|  |            |          | 7.6    | —   | 61.0    | $\mu\text{s}$ | When using sub clock<br>Min : $F_{CL} = 32\text{ kHz}$ , PLL multiplied by 4<br>Max : $F_{CL} = 32\text{ kHz}$ , divided by 2 |
| Source clock frequency   | $F_{SP}$   | —        | 0.5    | —   | 10.0    | MHz           | When using main clock   |
|  | $F_{SPL}$  | —        | 16.384 | —   | 131.072 | kHz           | When using sub clock  |
| Machine clock cycle time*2<br>(Minimum instruction execution time) | $t_{MCLK}$ | —        | 100    | —   | 32000   | ns            | When using main clock<br>Min : $F_{SP} = 10\text{ MHz}$ , no division<br>Max : $F_{SP} = 0.5\text{ MHz}$ , divided by 16      |
|  |            |          | 7.6    | —   | 976.5   | $\mu\text{s}$ | When using sub clock<br>Min : $F_{SPL} = 131\text{ kHz}$ , no division<br>Max : $F_{SPL} = 16\text{ kHz}$ , divided by 16     |
| Machine clock frequency  | $F_{MP}$   | —        | 0.031  | —   | 10.000  | MHz           | When using main clock   |
|  | $F_{MPL}$  | —        | 1.024  | —   | 131.072 | kHz           | When using sub clock  |

\*1 : Clock before setting division due to machine clock division ratio selection bit (SYCC : DIV1 and DIV0) . This source clock is divided by the machine clock division ratio selection bit (SYCC : DIV1 and DIV0) , and it becomes the machine clock. Further, the source clock can be selected as follows.

- Main clock divided by 2
- PLL multiplication of main clock (select from 1, 2, 2.5 multiplication)
- Sub clock divided by 2
- PLL multiplication of sub clock (select from 2, 3, 4 multiplication)

\*2 : Operation clock of the microcontroller. Machine clock can be selected as follows.

- Source clock (no division)
- Source clock divided by 4
- Source clock divided by 8
- Source clock divided by 16

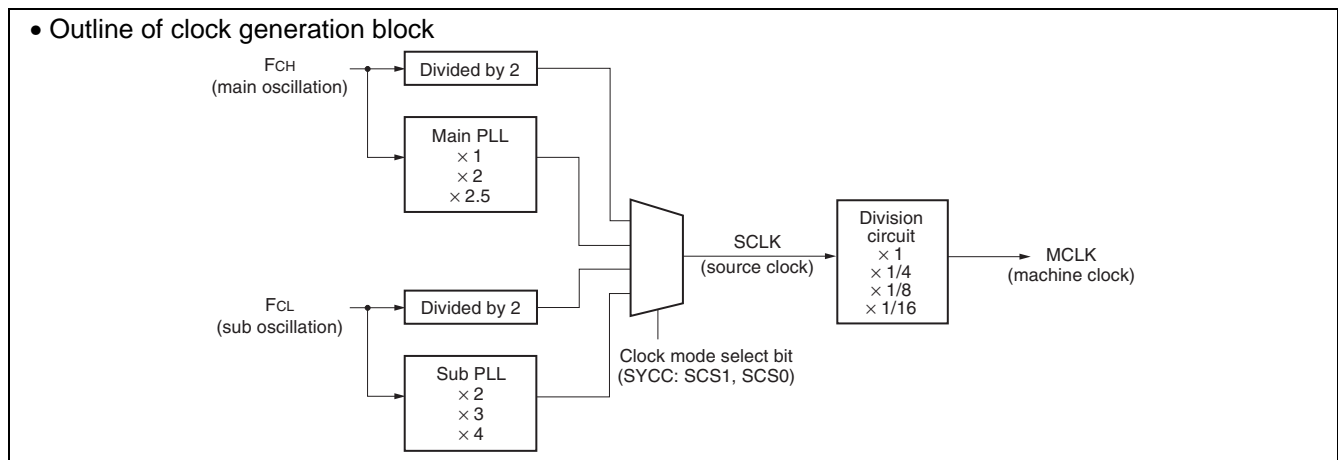

- **Operating voltage - Operating frequency ( $T_A = -40\text{ }^\circ\text{C}$  to  $+85\text{ }^\circ\text{C}$ )**
  - MB95F128H, MB95F128T

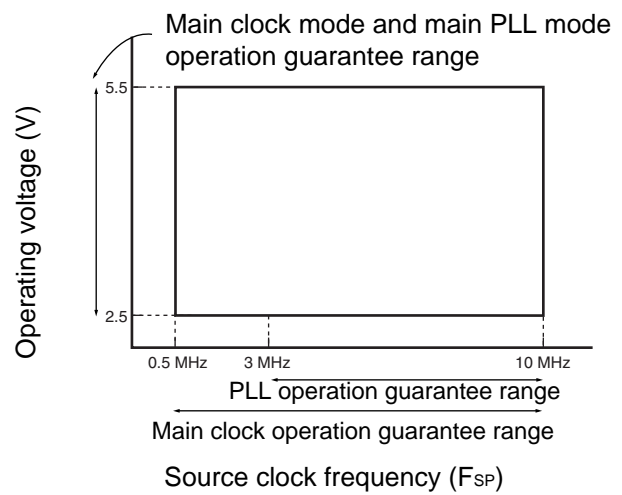
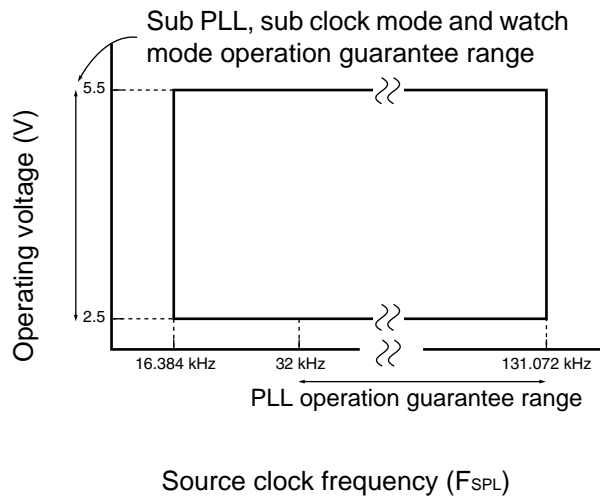

- **Operating voltage - Operating frequency ( $T_A = +5\text{ }^\circ\text{C}$  to  $+35\text{ }^\circ\text{C}$ )**
  - MB95FV100B-103

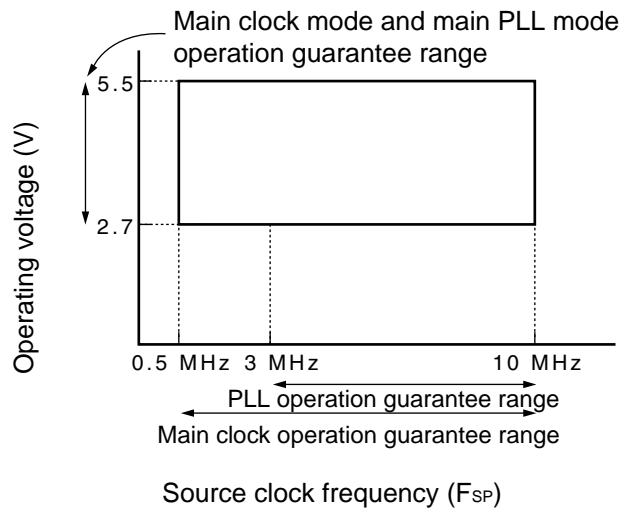
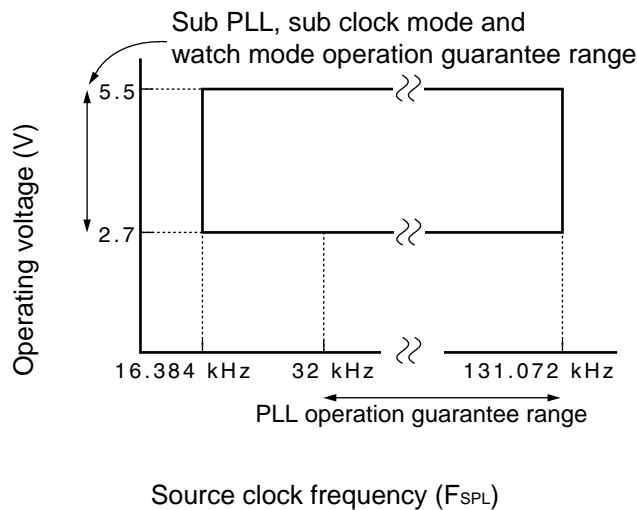

# MB95120H Series

- Main PLL operation frequency

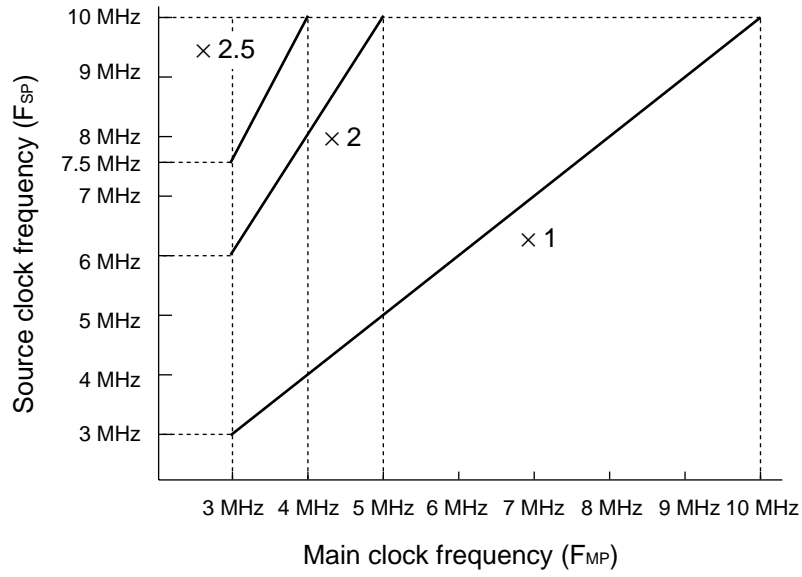

### (3) External Reset

( $V_{CC} = 5.0 \text{ V} \pm 10\%$ ,  $A_{V_{SS}} = V_{SS} = 0.0 \text{ V}$ ,  $T_A = -40 \text{ }^\circ\text{C}$  to  $+85 \text{ }^\circ\text{C}$ )

| Parameter                                     | Symbol            | Value  |     | Unit          | Remarks  |
|---|-------------------|--|-----|---------------|--|
|   |                   | Min  | Max |               |  |
| $\overline{\text{RST}}$ "L" level pulse width | $t_{\text{RSTL}}$ | $2 t_{\text{MCLK}}^{*1}$                           | —   | ns            | At normal operating  |
|   |                   | Oscillation time of oscillator <sup>*2</sup> + 100 | —   | $\mu\text{s}$ | At stop mode, sub clock mode, sub sleep mode, and watch mode |
|   |                   | 100  | —   |               | At timebase timer mode                                       |

\*1 : Refer to "(2) Source Clock/Machine Clock" for  $t_{\text{MCLK}}$ .

\*2 : Oscillation start time of oscillator is the time that the amplitude reaches 90 %. In the crystal oscillator, the oscillation time is between several ms and tens of ms. In ceramic oscillators, the oscillation time is between hundreds of  $\mu\text{s}$  and several ms. In the external clock, the oscillation time is 0 ms.

- At normal operating

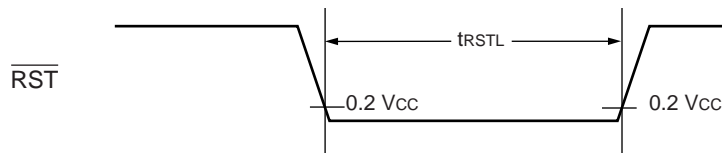

- At stop mode, sub clock mode, sub sleep mode, watch mode, and power-on

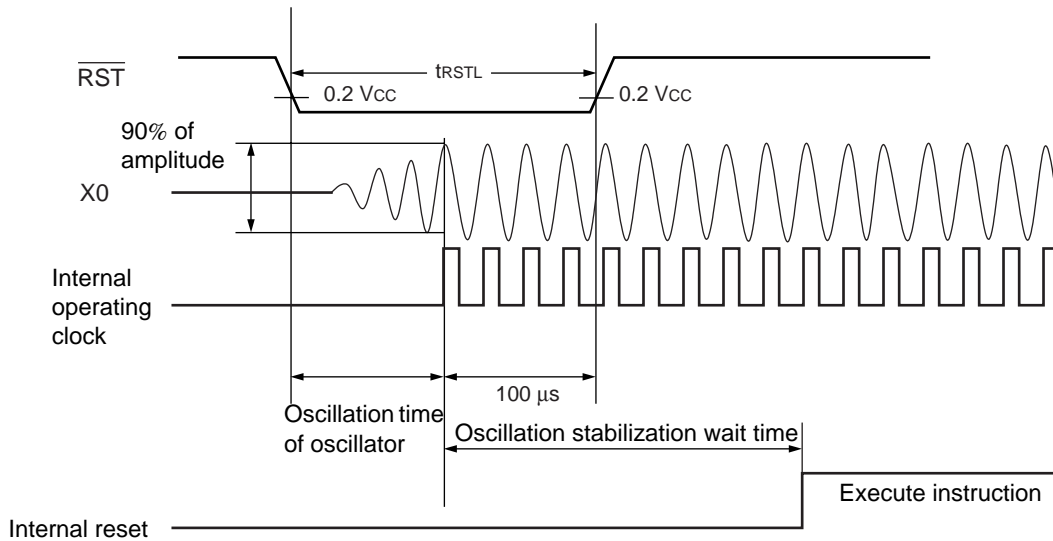

# MB95120H Series

## (4) Power-on Reset

( $A_{V_{SS}} = V_{SS} = 0.0 \text{ V}$ ,  $T_A = -40 \text{ }^\circ\text{C}$  to  $+85 \text{ }^\circ\text{C}$ )

| Parameter                | Symbol    | Conditions | Value |     | Unit | Remarks                     |
|--------------------------|-----------|------------|-------|-----|------|-----------------------------|
|                          |           |            | Min   | Max |      |                             |
| Power supply rising time | $t_R$     | —          | —     | 50  | ms   |                             |
| Power supply cutoff time | $t_{OFF}$ | —          | 1     | —   | ms   | Waiting time until power-on |

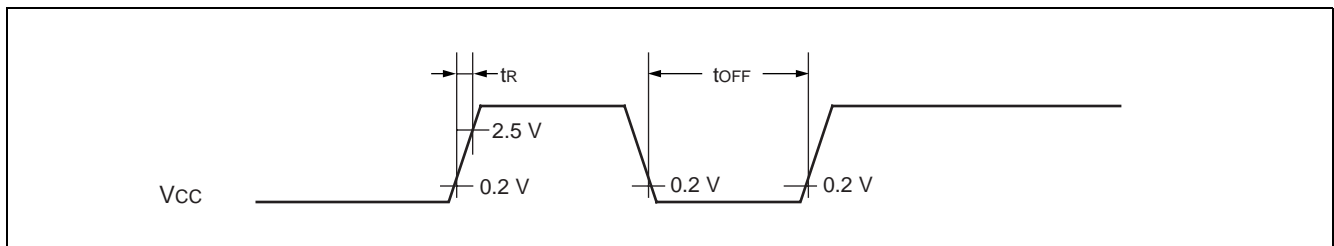

Note : Sudden change of power supply voltage may activate the power-on reset function. When changing power supply voltages during operation, set the slope of rising within 30 mV/ms as shown below.

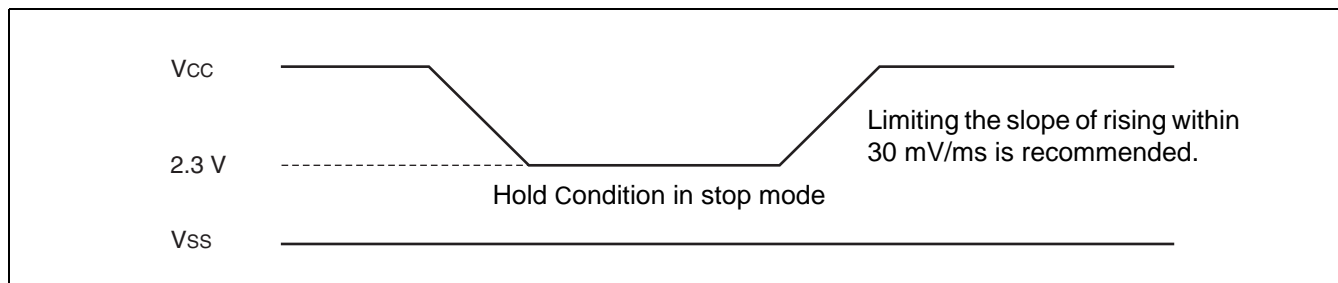

## (5) Peripheral Input Timing

( $V_{CC} = 5.0\text{ V} \pm 10\%$ ,  $AV_{SS} = V_{SS} = 0.0\text{ V}$ ,  $T_A = -40\text{ }^\circ\text{C}$  to  $+85\text{ }^\circ\text{C}$ )

| Parameter                        | Symbol    | Pin name                           | Value          |     | Unit | Remarks |
|----------------------------------|-----------|------------------------------------|----------------|-----|------|---------|
|                                  |           |                                    | Min            | Max |      |         |
| Peripheral input "H" pulse width | $t_{LIH}$ | INT00 to INT07,<br>INT10 to INT13, | $2 t_{MCLK}^*$ | —   | ns   |         |
| Peripheral input "L" pulse width | $t_{HIL}$ | EC0, EC1, T10, TRG0/ADTG,<br>TRG1  | $2 t_{MCLK}^*$ | —   | ns   |         |

\* : Refer to "(2) Source Clock/Machine Clock" for  $t_{MCLK}$ .

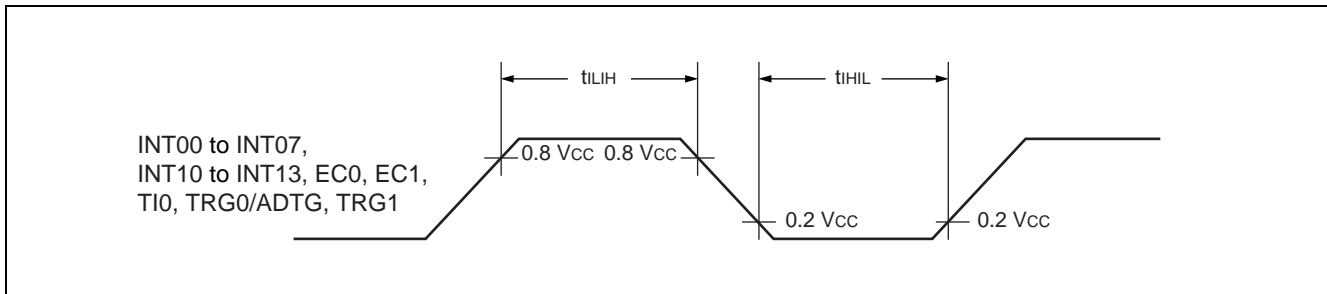

# MB95120H Series

## (6) UART/SIO, Serial I/O Timing

( $V_{CC} = 5.0\text{ V} \pm 10\%$ ,  $AV_{SS} = V_{SS} = 0.0\text{ V}$ ,  $T_A = -40\text{ }^\circ\text{C}$  to  $+85\text{ }^\circ\text{C}$ )

| Parameter                    | Symbol     | Pin name  | Conditions   | Value           |      | Unit | Remarks |
|------------------------------|------------|-----------|--|-----------------|------|------|---------|
|                              |            |           |  | Min             | Max  |      |         |
| Serial clock cycle time      | $t_{SCYC}$ | UCK0      | Internal clock operation output pin : $C_L = 80\text{ pF} + 1\text{TTL}$ . | $4\ t_{MCLK}^*$ | —    | ns   |         |
| UCK ↓ → UO time              | $t_{SLOV}$ | UCK0, UO0 |  | -190            | +190 | ns   |         |
| Valid UI → UCK ↑             | $t_{VSH}$  | UCK0, UI0 |  | $2\ t_{MCLK}^*$ | —    | ns   |         |
| UCK ↑ → valid UI hold time   | $t_{SHIX}$ | UCK0, UI0 |  | $2\ t_{MCLK}^*$ | —    | ns   |         |
| Serial clock "H" pulse width | $t_{SHSL}$ | UCK0      | External clock operation output pin : $C_L = 80\text{ pF} + 1\text{TTL}$ . | $4\ t_{MCLK}^*$ | —    | ns   |         |
| Serial clock "L" pulse width | $t_{SLSH}$ | UCK0      |  | $4\ t_{MCLK}^*$ | —    | ns   |         |
| UCK ↓ → UO time              | $t_{SLOV}$ | UCK0, UO0 |  | 0               | 190  | ns   |         |
| Valid UI → UCK ↑             | $t_{VSH}$  | UCK0, UI0 |  | $2\ t_{MCLK}^*$ | —    | ns   |         |
| UCK ↑ → valid UI hold time   | $t_{SHIX}$ | UCK0, UI0 | $2\ t_{MCLK}^*$  | —               | ns   |      |         |

\* : Refer to "(2) Source Clock/Machine Clock" for  $t_{MCLK}$ .

### • Internal shift clock mode

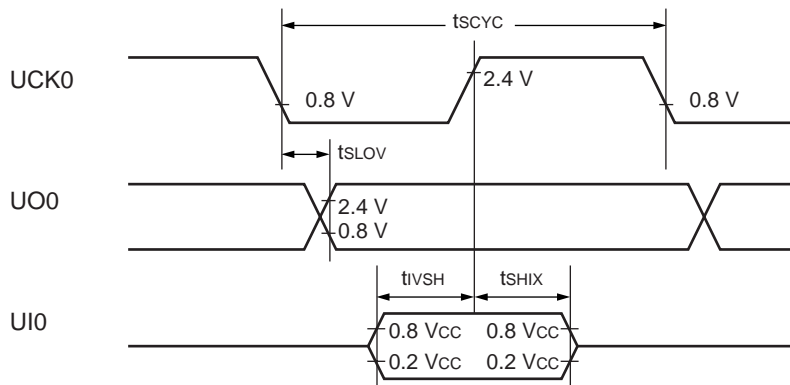

### • External shift clock mode

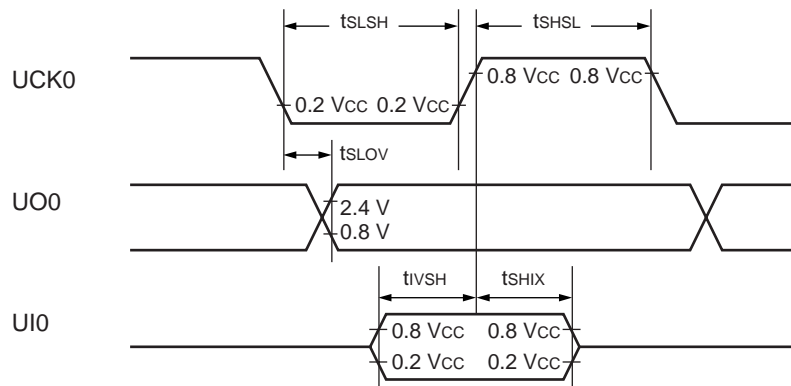

## (7) LIN-UART Timing

Sampling at the rising edge of sampling clock\*1 and prohibited serial clock delay\*2

(ESCR register : SCES bit = 0, ECCR register : SCDE bit = 0)

( $V_{CC} = 5.0\text{ V} \pm 10\%$ ,  $AV_{SS} = V_{SS} = 0.0\text{ V}$ ,  $T_A = -40\text{ }^\circ\text{C}$  to  $+85\text{ }^\circ\text{C}$ )

| Parameter                    | Symbol      | Pin name | Conditions  | Value                   |                        | Unit |
|------------------------------|-------------|----------|---|-------------------------|------------------------|------|
|                              |             |          |   | Min                     | Max                    |      |
| Serial clock cycle time      | $t_{SCYC}$  | SCK      | Internal clock<br>operation output pin :<br>$C_L = 80\text{ pF} + 1\text{ TTL}$ . | $5 t_{MCLK}^{*3}$       | —                      | ns   |
| SCK ↓ → SOT delay time       | $t_{SLOVI}$ | SCK, SOT |   | -95                     | +95                    | ns   |
| Valid SIN → SCK ↑            | $t_{IVSHI}$ | SCK, SIN |   | $t_{MCLK}^{*3} + 190$   | —                      | ns   |
| SCK ↑ → valid SIN hold time  | $t_{SHIXI}$ | SCK, SIN |   | 0                       | —                      | ns   |
| Serial clock "L" pulse width | $t_{SLSH}$  | SCK      | External clock<br>operation output pin :<br>$C_L = 80\text{ pF} + 1\text{ TTL}$ . | $3 t_{MCLK}^{*3} - t_R$ | —                      | ns   |
| Serial clock "H" pulse width | $t_{SHSL}$  | SCK      |   | $t_{MCLK}^{*3} + 95$    | —                      | ns   |
| SCK ↓ → SOT delay time       | $t_{SLOVE}$ | SCK, SOT |   | —                       | $2 t_{MCLK}^{*3} + 95$ | ns   |
| Valid SIN → SCK ↑            | $t_{IVSHE}$ | SCK, SIN |   | 190                     | —                      | ns   |
| SCK ↑ → valid SIN hold time  | $t_{SHIXE}$ | SCK, SIN |   | $t_{MCLK}^{*3} + 95$    | —                      | ns   |
| SCK fall time                | $t_F$       | SCK      |   | —                       | 10                     | ns   |
| SCK rise time                | $t_R$       | SCK      |   | —                       | 10                     | ns   |

\*1 : Provide switch function whether sampling of reception data is performed at rising edge or falling edge of the serial clock.

\*2 : Serial clock delay function is used to delay half clock for the output signal of serial clock.

\*3 : Refer to "(2) Source Clock/Machine Clock" for  $t_{MCLK}$ .

# MB95120H Series

- Internal shift clock mode

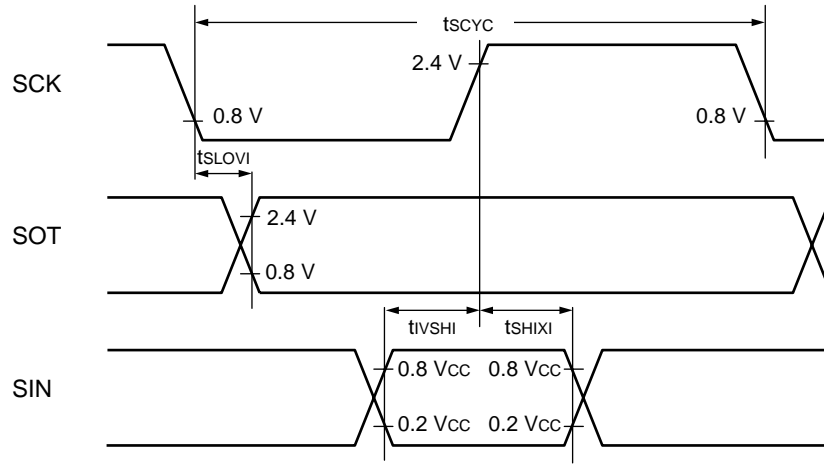

- External shift clock mode

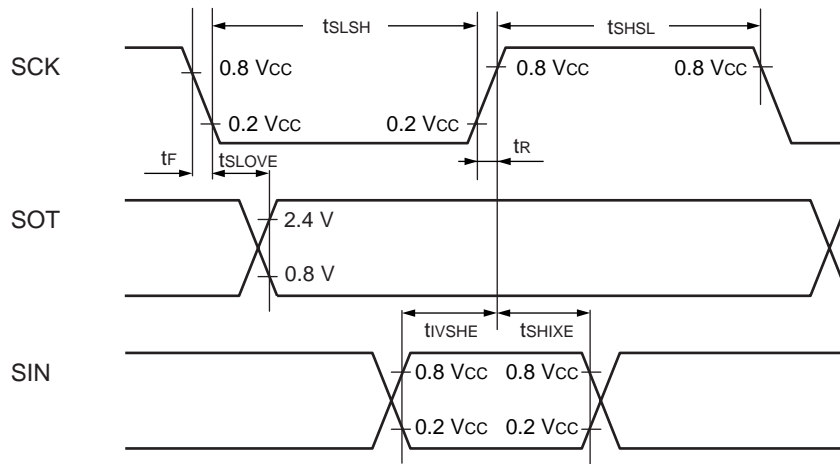

# MB95120H Series

Sampling at the falling edge of sampling clock\*1 and prohibited serial clock delay\*2  
(ESCR register : SCES bit = 1, ECCR register : SCDE bit = 0)

( $V_{CC} = 5.0\text{ V} \pm 10\%$ ,  $AV_{SS} = V_{SS} = 0.0\text{ V}$ ,  $T_A = -40\text{ }^\circ\text{C}$  to  $+85\text{ }^\circ\text{C}$ )

| Parameter  | Symbol      | Pin name | Conditions  | Value                   |                        | Unit |
|--|-------------|----------|---|-------------------------|------------------------|------|
|  |             |          |   | Min                     | Max                    |      |
| Serial clock cycle time                            | $t_{SCYC}$  | SCK      | Internal clock<br>operation output pin :<br>$C_L = 80\text{ pF} + 1\text{ TTL}$ . | $5 t_{MCLK}^{*3}$       | —                      | ns   |
| SCK $\uparrow$ $\rightarrow$ SOT delay time        | $t_{SHOVI}$ | SCK, SOT |   | -95                     | +95                    | ns   |
| Valid SIN $\rightarrow$ SCK $\downarrow$           | $t_{IVSLI}$ | SCK, SIN |   | $t_{MCLK}^{*3} + 190$   | —                      | ns   |
| SCK $\downarrow$ $\rightarrow$ valid SIN hold time | $t_{SLIXI}$ | SCK, SIN |   | 0                       | —                      | ns   |
| Serial clock "H" pulse width                       | $t_{SHSL}$  | SCK      | External clock<br>operation output pin :<br>$C_L = 80\text{ pF} + 1\text{ TTL}$ . | $3 t_{MCLK}^{*3} - t_R$ | —                      | ns   |
| Serial clock "L" pulse width                       | $t_{SLSH}$  | SCK      |   | $t_{MCLK}^{*3} + 95$    | —                      | ns   |
| SCK $\uparrow$ $\rightarrow$ SOT delay time        | $t_{SHOVE}$ | SCK, SOT |   | —                       | $2 t_{MCLK}^{*3} + 95$ | ns   |
| Valid SIN $\rightarrow$ SCK $\downarrow$           | $t_{IVSLE}$ | SCK, SIN |   | 190                     | —                      | ns   |
| SCK $\downarrow$ $\rightarrow$ valid SIN hold time | $t_{SLIXE}$ | SCK, SIN |   | $t_{MCLK}^{*3} + 95$    | —                      | ns   |
| SCK fall time                                      | $t_F$       | SCK      |   | —                       | 10                     | ns   |
| SCK rise time                                      | $t_R$       | SCK      |   | —                       | 10                     | ns   |

\*1 : Provide switch function whether sampling of reception data is performed at rising edge or falling edge of the serial clock.

\*2 : Serial clock delay function is used to delay half clock for the output signal of serial clock.

\*3 : Refer to " (2) Source Clock/Machine Clock" for  $t_{MCLK}$ .

# MB95120H Series

- Internal shift clock mode

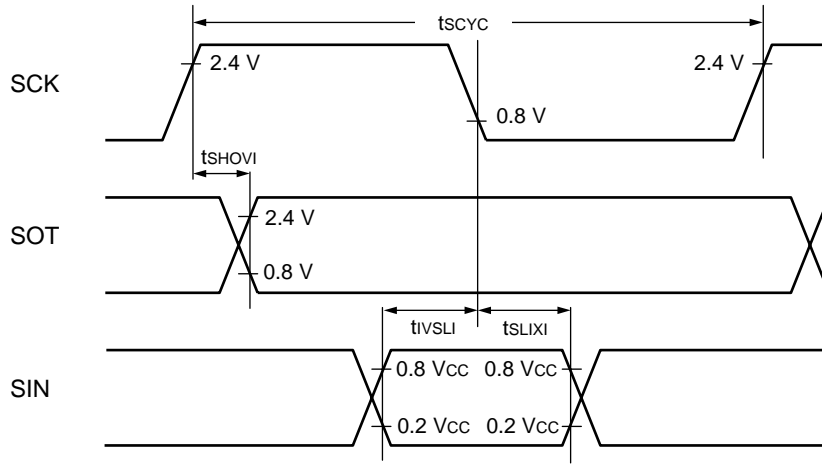

- External shift clock mode

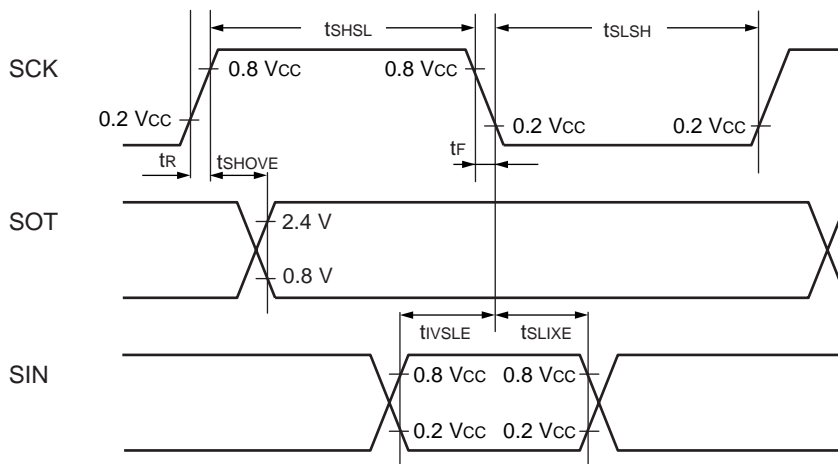

# MB95120H Series

Sampling at the rising edge of sampling clock\*<sup>1</sup> and enabled serial clock delay\*<sup>2</sup>  
 (ESCR register : SCES bit = 0, ECCR register : SCDE bit = 1)

( $V_{CC} = 5.0\text{ V} \pm 10\%$ ,  $AV_{SS} = V_{SS} = 0.0\text{ V}$ ,  $T_A = -40\text{ }^\circ\text{C}$  to  $+85\text{ }^\circ\text{C}$ )

| Parameter  | Symbol      | Pin name | Conditions   | Value                 |                   | Unit |
|--|-------------|----------|--|-----------------------|-------------------|------|
|  |             |          |  | Min                   | Max               |      |
| Serial clock cycle time                            | $t_{SCYC}$  | SCK      | Internal clock<br>operation output pin :<br>$C_L = 80\text{ pF} + 1\text{ TTL.}$ | $5 t_{MCLK}^{*3}$     | —                 | ns   |
| SCK $\uparrow$ $\rightarrow$ SOT delay time        | $t_{SHOVI}$ | SCK, SOT |  | -95                   | +95               | ns   |
| Valid SIN $\rightarrow$ SCK $\downarrow$           | $t_{IVSLI}$ | SCK, SIN |  | $t_{MCLK}^{*3} + 190$ | —                 | ns   |
| SCK $\downarrow$ $\rightarrow$ valid SIN hold time | $t_{SLIXI}$ | SCK, SIN |  | 0                     | —                 | ns   |
| SOT $\rightarrow$ SCK $\downarrow$ delay time      | $t_{SOVLI}$ | SCK, SOT |  | —                     | $4 t_{MCLK}^{*3}$ | ns   |

\*1 : Provide switch function whether sampling of reception data is performed at rising edge or falling edge of the serial clock.

\*2 : Serial clock delay function is used to delay half clock for the output signal of serial clock.

\*3 : Refer to “ (2) Source Clock/Machine Clock” for  $t_{MCLK}$ .

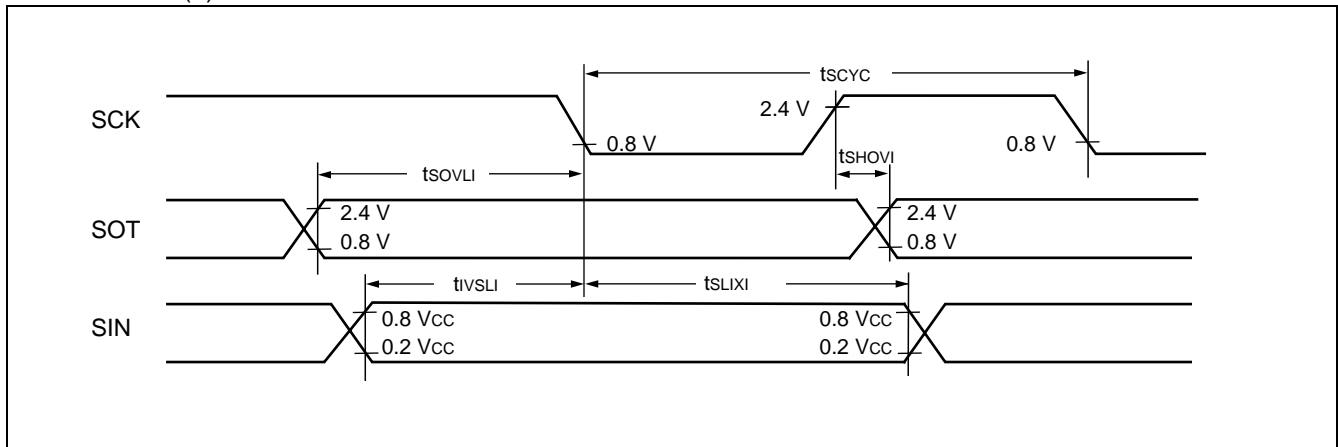

# MB95120H Series

Sampling at the falling edge of sampling clock\*1 and enabled serial clock delay\*2  
 (ESCR register : SCES bit = 1, ECCR register : SCDE bit = 1)

( $V_{CC} = 5.0\text{ V} \pm 10\%$ ,  $AV_{SS} = V_{SS} = 0.0\text{ V}$ ,  $T_A = -40\text{ }^\circ\text{C}$  to  $+85\text{ }^\circ\text{C}$ )

| Parameter                   | Symbol      | Pin name | Conditions   | Value                 |                   | Unit |
|-----------------------------|-------------|----------|--|-----------------------|-------------------|------|
|                             |             |          |  | Min                   | Max               |      |
| Serial clock cycle time     | $t_{SCYC}$  | SCK      | Internal clock<br>operating output pin :<br>$C_L = 80\text{ pF} + 1\text{ TTL.}$ | $5 t_{MCLK}^{*3}$     | —                 | ns   |
| SCK ↓ → SOT delay time      | $t_{SLOVI}$ | SCK, SOT |  | -95                   | +95               | ns   |
| Valid SIN → SCK ↑           | $t_{IVSHI}$ | SCK, SIN |  | $t_{MCLK}^{*3} + 190$ | —                 | ns   |
| SCK ↑ → valid SIN hold time | $t_{SHIXI}$ | SCK, SIN |  | 0                     | —                 | ns   |
| SOT → SCK ↑ delay time      | $t_{SOVHI}$ | SCK, SOT |  | —                     | $4 t_{MCLK}^{*3}$ | ns   |

\*1 : Provide switch function whether sampling of reception data is performed at rising edge or falling edge of the serial clock.

\*2 : Serial clock delay function is used to delay half clock for the output signal of serial clock.

\*3 : Refer to “ (2) Source Clock/Machine Clock” for  $t_{MCLK}$ .

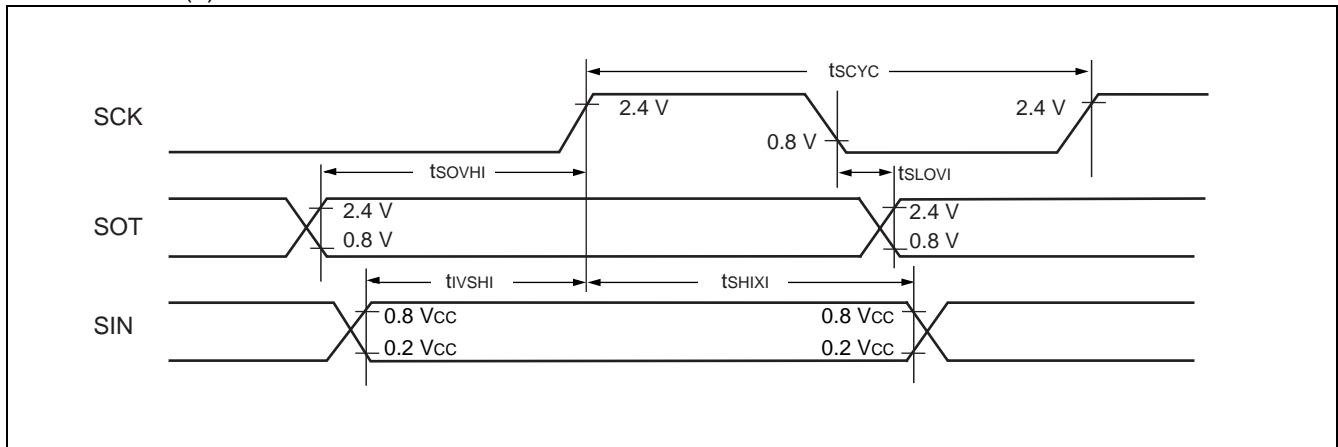

## (8) I<sup>2</sup>C Timing

(V<sub>CC</sub> = 5.0 V ± 10%, AV<sub>SS</sub> = V<sub>SS</sub> = 0.0 V, T<sub>A</sub> = -40 °C to +85 °C)

| Parameter   | Sym-<br>bol         | Pin<br>name  | Conditions                 | Value             |        |           |       | Unit | Re-<br>marks |
|---|---------------------|--------------|----------------------------|-------------------|--------|-----------|-------|------|--------------|
|   |                     |              |                            | Standard-<br>mode |        | Fast-mode |       |      |              |
|   |                     |              |                            | Min               | Max    | Min       | Max   |      |              |
| SCL clock frequency   | f <sub>SCL</sub>    | SCL0         |                            | 0                 | 100    | 0         | 400   | kHz  |              |
| (Repeat) Start condition hold time<br>SDA ↓ → SCL ↓         | t <sub>HD;STA</sub> | SCL0<br>SDA0 | R = 1.7 kΩ,<br>C = 50 pF*1 | 4.0               | —      | 0.6       | —     | μs   |              |
| SCL clock "L" width   | t <sub>LOW</sub>    | SCL0         |                            | 4.7               | —      | 1.3       | —     | μs   |              |
| SCL clock "H" width   | t <sub>HIGH</sub>   | SCL0         |                            | 4.0               | —      | 0.6       | —     | μs   |              |
| (Repeat) Start condition setup time<br>SCL ↑ → SDA ↓        | t <sub>SU;STA</sub> | SCL0<br>SDA0 |                            | 4.7               | —      | 0.6       | —     | μs   |              |
| Data hold time SCL ↓ → SDA ↓ ↑                              | t <sub>HD;DAT</sub> | SCL0<br>SDA0 |                            | 0                 | 3.45*2 | 0         | 0.9*3 | μs   |              |
| Data setup time SDA ↓ ↑ → SCL ↑                             | t <sub>SU;DAT</sub> | SCL0<br>SDA0 |                            | 0.25              | —      | 0.1       | —     | μs   |              |
| Stop condition setup time SCL ↑ →<br>SDA ↑                  | t <sub>SU;STO</sub> | SCL0<br>SDA0 |                            | 4                 | —      | 0.6       | —     | μs   |              |
| Bus free time between stop<br>condition and start condition | t <sub>BUF</sub>    | SCL0<br>SDA0 |                            | 4.7               | —      | 1.3       | —     | μs   |              |

\*1 : R, C : Pull-up resistor and load capacitor of the SCL and SDA lines.

\*2 : The maximum t<sub>HD;DAT</sub> have only to be met if the device dose not stretch the "L" width (t<sub>LOW</sub>) of the SCL signal.

\*3 : A fast-mode I<sup>2</sup>C-bus device can be used in a standard-mode I<sup>2</sup>C-bus system, but the requirement t<sub>SU;DAT</sub> ≥ 250 ns must then be met.

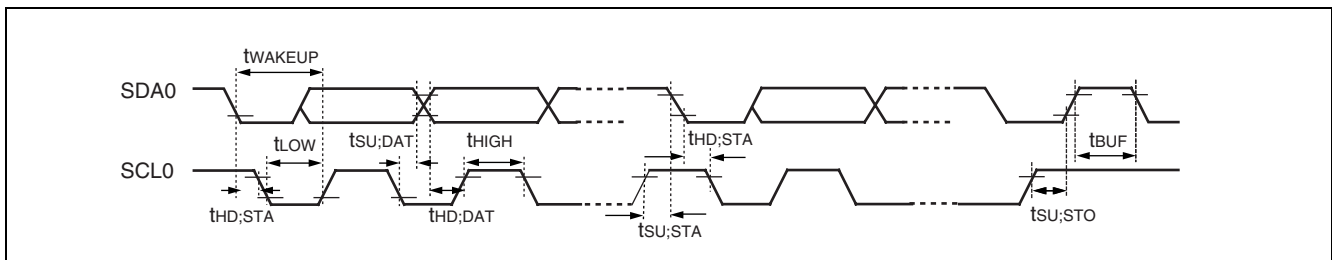

# MB95120H Series

( $V_{CC} = 5.0 \text{ V} \pm 10\%$ ,  $AV_{SS} = V_{SS} = 0.0 \text{ V}$ ,  $T_A = -40 \text{ }^\circ\text{C}$  to  $+85 \text{ }^\circ\text{C}$ )

| Parameter  | Symbol       | Pin name     | Condi-tions                         | Value*2                       |                               | Unit | Remarks  |
|--|--------------|--------------|-------------------------------------|-------------------------------|-------------------------------|------|--|
|  |              |              |                                     | Min                           | Max                           |      |  |
| SCL clock "L" width                                      | $t_{LOW}$    | SCL0         | R = 1.7 k $\Omega$ ,<br>C = 50 pF*1 | $(2 + nm / 2) t_{MCLK} - 20$  | —                             | ns   | Master mode  |
| SCL clock "H" width                                      | $t_{HIGH}$   | SCL0         |                                     | $(nm / 2) t_{MCLK} - 20$      | $(nm / 2) t_{MCLK} + 20$      | ns   | Master mode  |
| Start condition hold time                                | $t_{HD,STA}$ | SCL0<br>SDA0 |                                     | $(-1 + nm / 2) t_{MCLK} - 20$ | $(-1 + nm) t_{MCLK} + 20$     | ns   | Master mode<br>Maximum value is applied when m, n = 1, 8. Otherwise, the minimum value is applied.   |
| Stop condition setup time                                | $t_{SU,STO}$ | SCL0<br>SDA0 |                                     | $(1 + nm / 2) t_{MCLK} - 20$  | $(1 + nm / 2) t_{MCLK} + 20$  | ns   | Master mode  |
| Start condition setup time                               | $t_{SU,STA}$ | SCL0<br>SDA0 |                                     | $(1 + nm / 2) t_{MCLK} - 20$  | $(1 + nm / 2) t_{MCLK} + 20$  | ns   | Master mode  |
| Bus free time between stop condition and start condition | $t_{BUF}$    | SCL0<br>SDA0 |                                     | $(2 nm + 4) t_{MCLK} - 20$    | —                             | ns   |  |
| Data hold time   | $t_{HD,DAT}$ | SCL0<br>SDA0 |                                     | $3 t_{MCLK} - 20$             | —                             | ns   | Master mode  |
| Data setup time  | $t_{SU,DAT}$ | SCL0<br>SDA0 |                                     | $(-2 + nm / 2) t_{MCLK} - 20$ | $(-1 + nm / 2) t_{MCLK} + 20$ | ns   | Master mode<br>When assuming that "L" of SCL is not extended, the minimum value is applied to first bit of continuous data. Otherwise, the maximum value is applied. |
| Setup time between clearing interrupt and SCL rising     | $t_{SU,INT}$ | SCL0         |                                     | $(nm / 2) t_{MCLK} - 20$      | $(1 + nm / 2) t_{MCLK} + 20$  | ns   | Minimum value is applied to interrupt at 9th SCL $\downarrow$ . Maximum value is applied to interrupt at 8th SCL $\downarrow$ .                                      |
| SCL clock "L" width                                      | $t_{LOW}$    | SCL0         |                                     | $4 t_{MCLK} - 20$             | —                             | ns   | At reception   |
| SCL clock "H" width                                      | $t_{HIGH}$   | SCL0         |                                     | $4 t_{MCLK} - 20$             | —                             | ns   | At reception   |
| Start condition detection                                | $t_{HD,STA}$ | SCL0<br>SDA0 |                                     | $2 t_{MCLK} - 20$             | —                             | ns   | Undetected when $1 t_{MCLK}$ is used at reception  |

(Continued)

# MB95120H Series

(Continued)

( $V_{CC} = 5.0\text{ V} \pm 10\%$ ,  $AV_{SS} = V_{SS} = 0.0\text{ V}$ ,  $T_A = -40\text{ }^\circ\text{C}$  to  $+85\text{ }^\circ\text{C}$ )

| Parameter  | Symbol        | Pin name     | Conditions                          | Value*2   |     | Unit | Remarks   |
|--|---------------|--------------|-------------------------------------|---|-----|------|---|
|  |               |              |                                     | Min   | Max |      |   |
| Stop condition detection                                 | $t_{SU;STO}$  | SCL0<br>SDA0 | R = 1.7 k $\Omega$ ,<br>C = 50 pF*1 | $2 t_{MCLK} - 20$                                       | —   | ns   | Undetected when 1 $t_{MCLK}$ is used at reception |
| Restart condition detection condition                    | $t_{SU;STA}$  | SCL0<br>SDA0 |                                     | $2 t_{MCLK} - 20$                                       | —   | ns   | Undetected when 1 $t_{MCLK}$ is used at reception |
| Bus free time  | $t_{BUF}$     | SCL0<br>SDA0 |                                     | $2 t_{MCLK} - 20$                                       | —   | ns   | At reception                                      |
| Data hold time   | $t_{HD;DAT}$  | SCL0<br>SDA0 |                                     | $2 t_{MCLK} - 20$                                       | —   | ns   | At slave transmission mode                        |
| Data setup time  | $t_{SU;DAT}$  | SCL0<br>SDA0 |                                     | $t_{LOW} - 3 t_{MCLK} - 20$                             | —   | ns   | At slave transmission mode                        |
| Data hold time   | $t_{HD;DAT}$  | SCL0<br>SDA0 |                                     | 0   | —   | ns   | At reception                                      |
| Data setup time  | $t_{SU;DAT}$  | SCL0<br>SDA0 |                                     | $t_{MCLK} - 20$   | —   | ns   | At reception                                      |
| SDA $\downarrow$ →SCL $\uparrow$<br>(at wakeup function) | $t_{WAKE-UP}$ | SCL0<br>SDA0 |                                     | Oscillation stabilization wait time + $2 t_{MCLK} - 20$ | —   | ns   |   |

\*1 : R, C : Pull-up resistor and load capacitor of the SCL and SDA lines.

\*2 : • Refer to “(2) Source Clock/Machine Clock” for  $t_{MCLK}$ .

- m is CS4 bit and CS3 bit (bit 4 and bit 3) of I<sup>2</sup>C clock control register (ICCR) .
- n is CS2 bit to CS0 bit (bit 2 to bit 0) of I<sup>2</sup>C clock control register (ICCR) .
- Actual timing of I<sup>2</sup>C is determined by m and n values set by the machine clock ( $t_{MCLK}$ ) and CS4 to CS0 of ICCR0 register.
- Standard-mode :  
m and n can be set at the range : 0.9 MHz <  $t_{MCLK}$  (machine clock) < 10 MHz.  
Setting of m and n determines the machine clock that can be used below.
 

|  |                                 |
|--|---------------------------------|
| (m, n) = (1, 8)                                  | : 0.9 MHz < $t_{MCLK}$ ≤ 1 MHz  |
| (m, n) = (1, 22), (5, 4), (6, 4), (7, 4), (8, 4) | : 0.9 MHz < $t_{MCLK}$ ≤ 2 MHz  |
| (m, n) = (1, 38), (5, 8), (6, 8), (7, 8), (8, 8) | : 0.9 MHz < $t_{MCLK}$ ≤ 4 MHz  |
| (m, n) = (1, 98)                                 | : 0.9 MHz < $t_{MCLK}$ ≤ 10 MHz |
- Fast-mode :  
m and n can be set at the range : 3.3 MHz <  $t_{MCLK}$  (machine clock) < 10 MHz.  
Setting of m and n determines the machine clock that can be used below.
 

|                          |                                 |
|--------------------------|---------------------------------|
| (m, n) = (1, 8)          | : 3.3 MHz < $t_{MCLK}$ ≤ 4 MHz  |
| (m, n) = (1, 22), (5, 4) | : 3.3 MHz < $t_{MCLK}$ ≤ 8 MHz  |
| (m, n) = (6, 4)          | : 3.3 MHz < $t_{MCLK}$ ≤ 10 MHz |

# MB95120H Series

## (9) Low Voltage Detection

(AV<sub>SS</sub> = V<sub>SS</sub> = 0.0 V, T<sub>A</sub> = -40 °C to +85 °C)

| Parameter   | Symbol           | Value |      |      | Unit | Remarks   |
|---|------------------|-------|------|------|------|---|
|   |                  | Min   | Typ  | Max  |      |   |
| Release voltage   | V <sub>DL+</sub> | 2.55  | 2.70 | 2.85 | V    | At power-supply rise  |
| Detection voltage                                       | V <sub>DL-</sub> | 2.45  | 2.60 | 2.75 | V    | At power-supply fall  |
| Hysteresis width  | V <sub>HYS</sub> | 70    | 100  | —    | mV   |   |
| Power-supply start voltage                              | V <sub>off</sub> | —     | —    | 2.3  | V    |   |
| Power-supply end voltage                                | V <sub>on</sub>  | 4.9   | —    | —    | V    |   |
| Power-supply voltage change time (at power supply rise) | t <sub>r</sub>   | 0.3   | —    | —    | μs   | Slope of power supply that reset release signal generates                                     |
|   |                  | —     | 3000 | —    | μs   | Slope of power supply that reset release signal generates within rating (V <sub>DL+</sub> )   |
| Power-supply voltage change time (at power supply fall) | t <sub>f</sub>   | 300   | —    | —    | μs   | Slope of power supply that reset detection signal generates                                   |
|   |                  | —     | 300  | —    | μs   | Slope of power supply that reset detection signal generates within rating (V <sub>DL-</sub> ) |
| Reset release delay time                                | t <sub>d1</sub>  | —     | —    | 400  | μs   |   |
| Reset detection delay time                              | t <sub>d2</sub>  | —     | —    | 30   | μs   |   |
| Current consumption                                     | I <sub>LVD</sub> | —     | 38   | 50   | μA   | Current consumption of low voltage detection circuit only                                     |

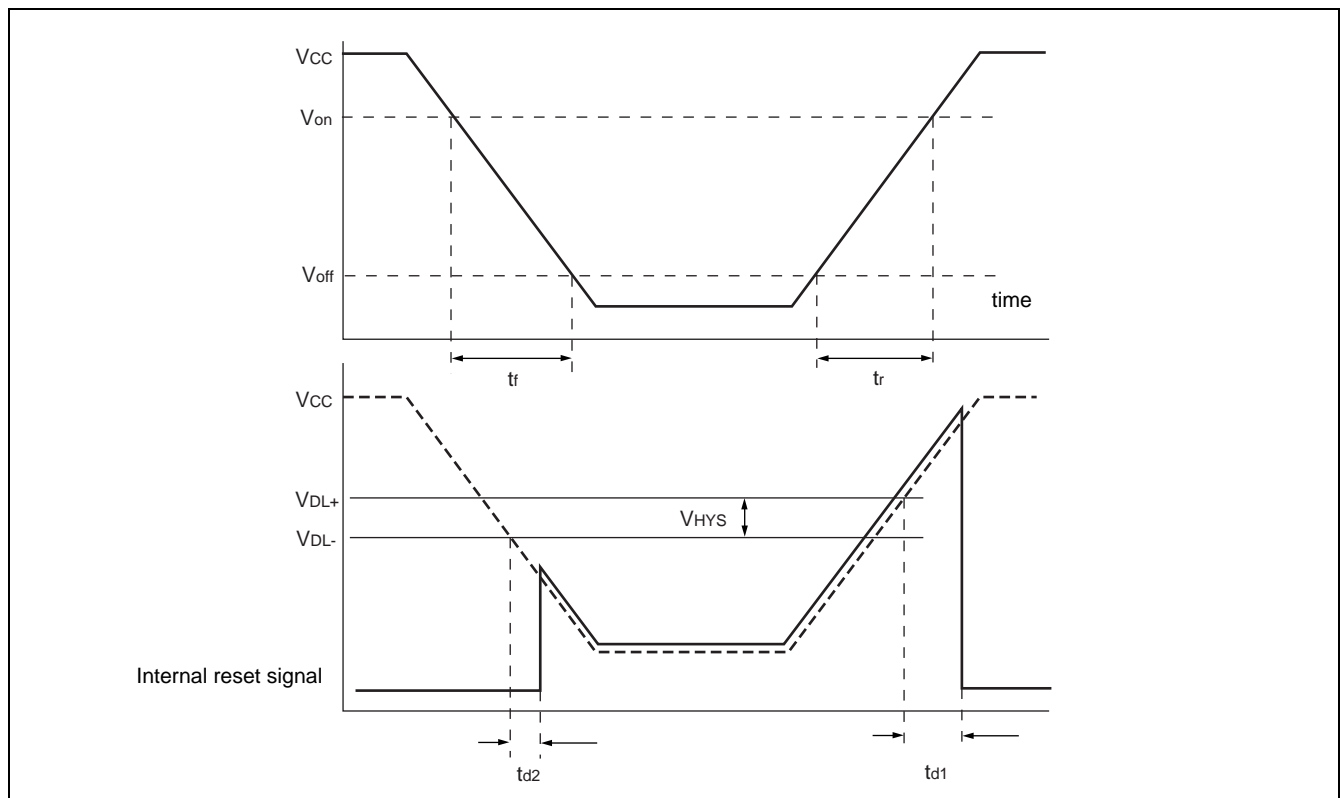

## 5. A/D Converter

### (1) A/D Converter Electrical Characteristics

(AVcc = Vcc = 4.0 V to 5.5 V, AVss = Vss = 0.0 V, TA = -40 °C to +85 °C)

| Parameter                        | Symbol           | Value          |                |                | Unit | Remarks   |
|----------------------------------|------------------|----------------|----------------|----------------|------|---|
|                                  |                  | Min            | Typ            | Max            |      |   |
| Resolution                       | —                | —              | —              | 10             | bit  |   |
| Total error                      |                  | -3.0           | —              | +3.0           | LSB  |   |
| Linearity error                  |                  | -2.5           | —              | +2.5           | LSB  |   |
| Differential linear error        |                  | -1.9           | —              | +1.9           | LSB  |   |
| Zero transition voltage          | V <sub>0T</sub>  | AVss - 1.5 LSB | AVss + 0.5 LSB | AVss + 2.5 LSB | V    |   |
| Full-scale transition voltage    | V <sub>FST</sub> | AVR - 3.5 LSB  | AVR - 1.5 LSB  | AVR + 0.5 LSB  | V    |   |
| Compare time                     | —                | 0.9            | —              | 16500          | μs   | 4.5 V ≤ AVcc ≤ 5.5 V                                    |
|                                  |                  | 1.8            | —              | 16500          | μs   | 4.0 V ≤ AVcc < 4.5 V                                    |
| Sampling time                    | —                | 0.6            | —              | ∞              | μs   | 4.5 V ≤ AVcc ≤ 5.5 V,<br>At external impedance < 5.4 kΩ |
|                                  |                  | 1.2            | —              | ∞              | μs   | 4.0 V ≤ AVcc < 4.5 V,<br>At external impedance < 2.4 kΩ |
| Analog input current             | I <sub>AIN</sub> | -0.3           | —              | +0.3           | μA   |   |
| Analog input voltage             | V <sub>AIN</sub> | AVss           | —              | AVR            | V    |   |
| Reference voltage                | —                | AVss + 4.0     | —              | AVcc           | V    | AVR pin   |
| Reference voltage supply current | I <sub>R</sub>   | —              | 600            | 900            | μA   | AVR pin,<br>During A/D operation                        |
|                                  | I <sub>RH</sub>  | —              | —              | 5              | μA   | AVR pin,<br>At stop mode                                |

# MB95120H Series

## (2) Notes on Using A/D Converter

### • About the external impedance of analog input and its sampling time

A/D converter with sample and hold circuit. If the external impedance is too high to keep sufficient sampling time, the analog voltage charged to the internal sample and hold capacitor is insufficient, adversely affecting A/D conversion precision. Therefore to satisfy the A/D conversion precision standard, consider the relationship between the external impedance and minimum sampling time and either adjust the register value and operating frequency or decrease the external impedance so that the sampling time is longer than the minimum value. Also, if the sampling time cannot be sufficient, connect a capacitor of about 0.1  $\mu\text{F}$  to the analog input pin.

#### • Analog input equivalent circuit

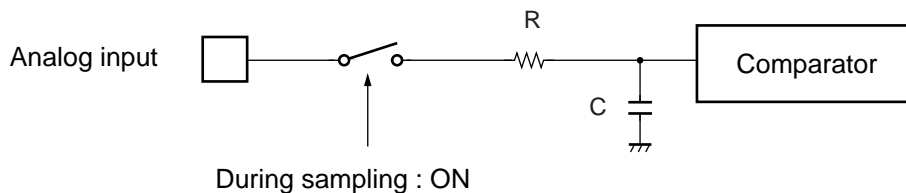

|   | R                    | C           |
|---|----------------------|-------------|
| $4.5 \text{ V} \leq AV_{CC} \leq 5.5 \text{ V}$ | 2.0 k $\Omega$ (Max) | 16 pF (Max) |
| $4.0 \text{ V} \leq AV_{CC} < 4.5 \text{ V}$    | 8.2 k $\Omega$ (Max) | 16 pF (Max) |

Note : The values are reference values.

#### • The relationship between external impedance and minimum sampling time

(External impedance = 0 k $\Omega$  to 100 k $\Omega$ )

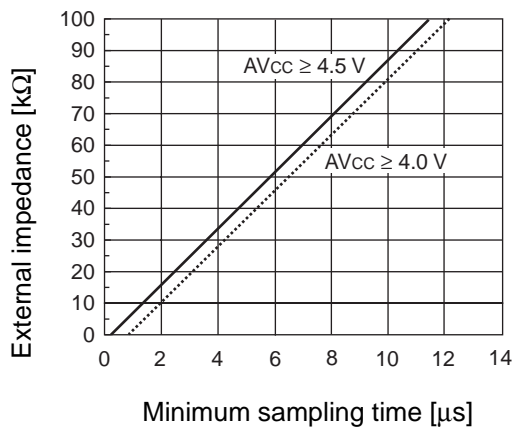

(External impedance = 0 k $\Omega$  to 20 k $\Omega$ )

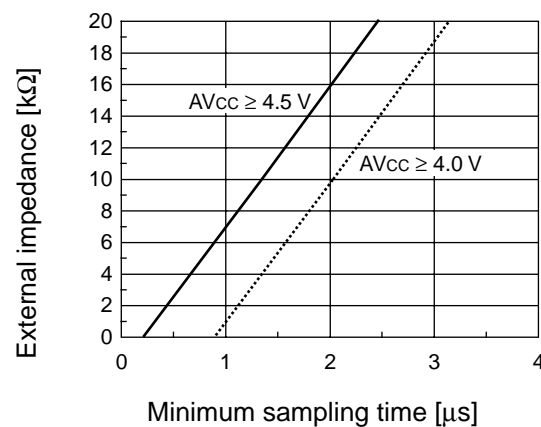

### • About errors

As  $|AV_{CC} - AV_{SS}|$  becomes smaller, values of relative errors grow larger.

**(3) Definition of A/D Converter Terms**

- Resolution  
The level of analog variation that can be distinguished by the A/D converter.  
When the number of bits is 10, analog voltage can be divided into  $2^{10} = 1024$ .
- Linearity error (unit : LSB)  
The deviation between the value along a straight line connecting the zero transition point (“00 0000 0000” ← → “00 0000 0001”) of a device and the full-scale transition point (“11 1111 1111” ← → “11 1111 1110”) compared with the actual conversion values obtained.
- Differential linear error (Unit : LSB)  
Deviation of input voltage, which is required for changing output code by 1 LSB, from an ideal value.
- Total error (unit: LSB)  
Difference between actual and theoretical values, caused by a zero transition error, full-scale transition error, linearity error, quantum error, and noise.

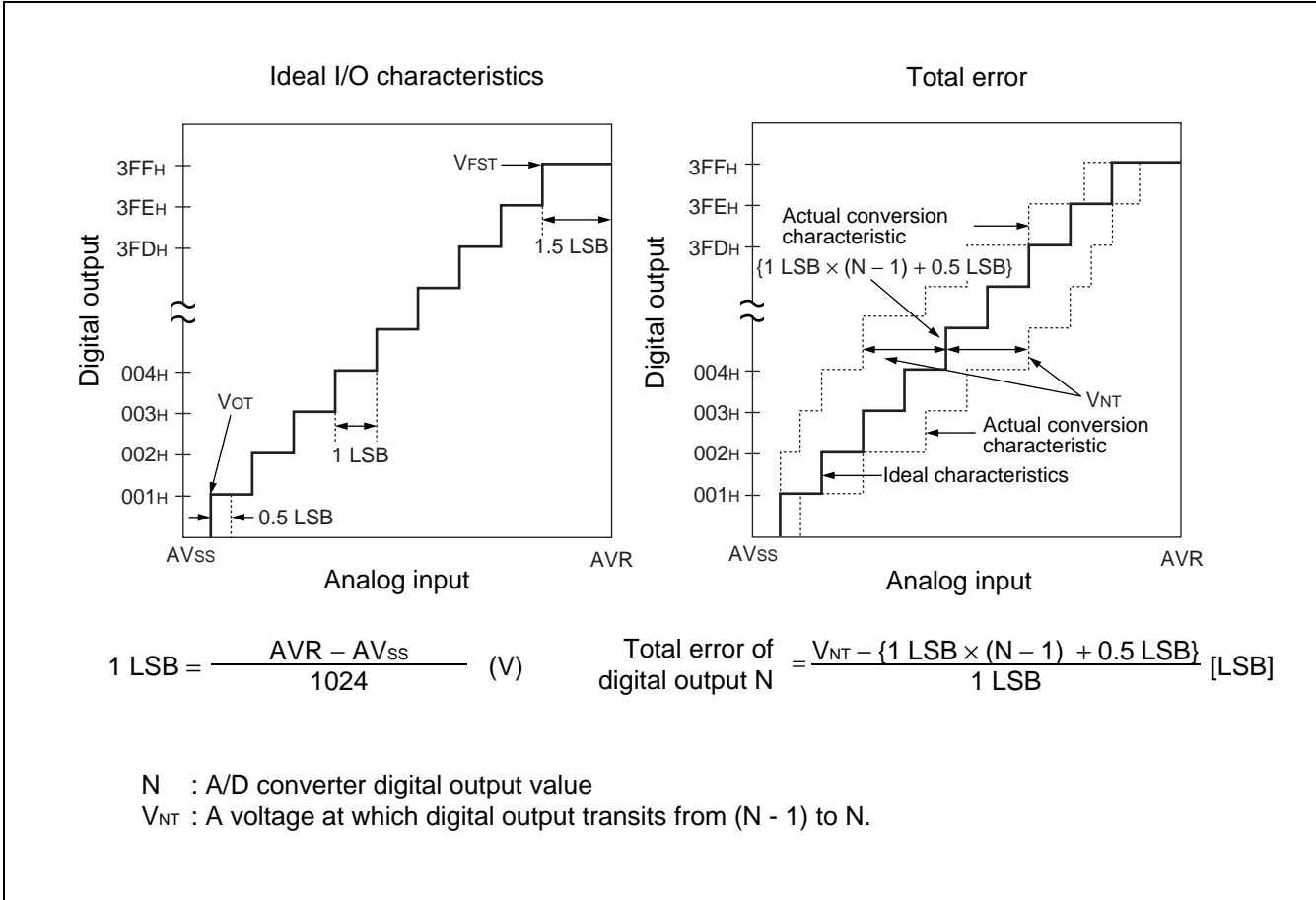

(Continued)

# MB95120H Series

(Continued)

Zero transition error

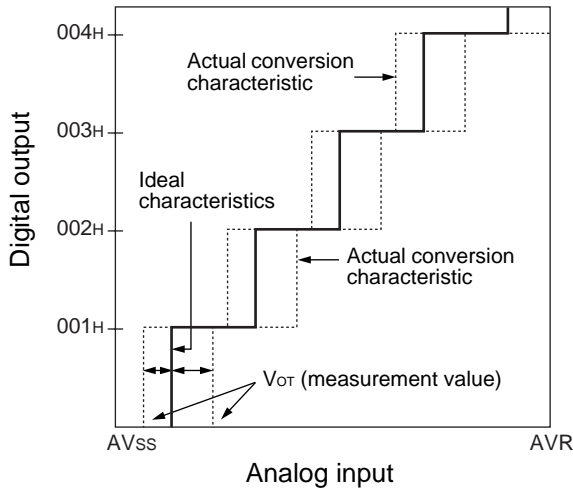

Full-scale transition error

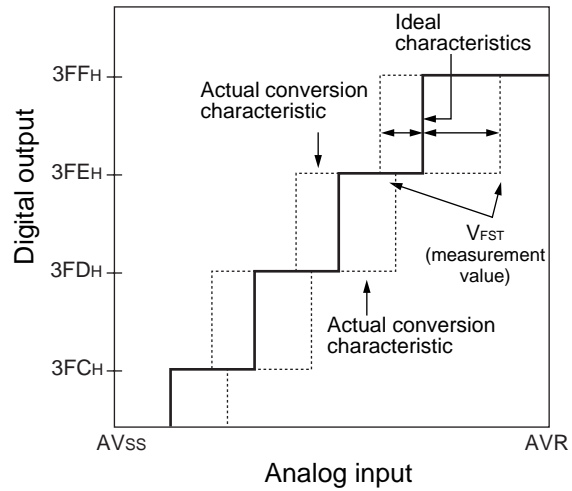

Linearity error

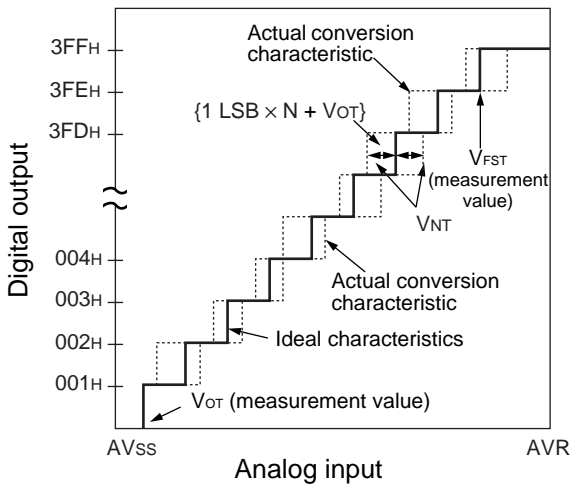

Differential linear error

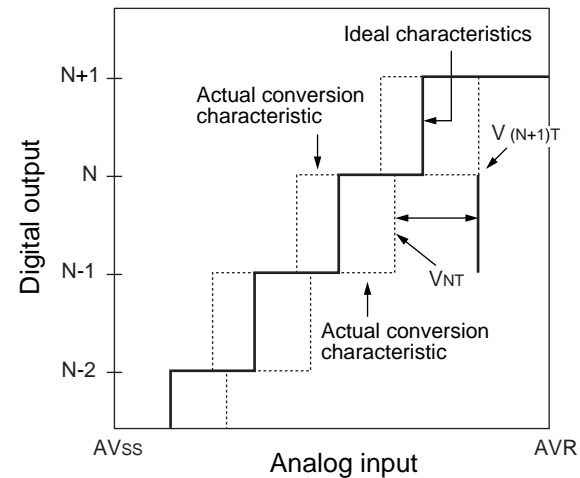

$$\text{Linear error in digital output } N = \frac{V_{NT} - \{1 \text{ LSB} \times N + V_{OT}\}}{1 \text{ LSB}}$$

$$\text{Differential linear error in digital output } N = \frac{V_{(N+1)T} - V_{NT}}{1 \text{ LSB}} - 1$$

N : A/D Converter digital output value

$V_{NT}$  : A voltage at which digital output transits from (N - 1) to N.

$V_{OT}$  (Ideal value) =  $AV_{SS} + 0.5 \text{ LSB [V]}$

$V_{FST}$  (Ideal value) =  $AVR - 1.5 \text{ LSB [V]}$

## 6. Flash Memory Program/Erase Characteristics

| Parameter                                | Value            |                   |                   | Unit  | Remarks   |
|--|------------------|-------------------|-------------------|-------|---|
|  | Min              | Typ               | Max               |       |   |
| Sector erase time<br>(4K bytes sector)   | —                | 0.2* <sup>1</sup> | 0.5* <sup>2</sup> | s     | Excludes 00 <sub>H</sub> programming prior erasure. |
| Sector erase time<br>(16K bytes sector)  | —                | 0.5* <sup>1</sup> | 7.5* <sup>2</sup> | s     | Excludes 00 <sub>H</sub> programming prior erasure. |
| Byte programming time                    | —                | 32                | 3600              | μs    | Excludes system-level overhead.                     |
| Program/erase cycle                      | 10000            | —                 | —                 | cycle |   |
| Power supply voltage at<br>program/erase | 4.5              | —                 | 5.5               | V     |   |
| Flash memory data retention<br>time      | 20* <sup>3</sup> | —                 | —                 | year  | Average T <sub>A</sub> = +85 °C                     |

\*1 : T<sub>A</sub> = + 25 °C, V<sub>CC</sub> = 5.0 V, 10000 cycles

\*2 : T<sub>A</sub> = + 85 °C, V<sub>CC</sub> = 4.5 V, 10000 cycles

\*3 : This value comes from the technology qualification (using Arrhenius equation to translate high temperature measurements into normalized value at +85 °C) .

# MB95120H Series

## ■ MASK OPTION

| No. | Part number   | MB95F128H<br>MB95F128T  | MB95FV100B-103  |
|-----|---|---|---|
|     | Specifying procedure  | Setting disabled  | Setting disabled  |
| 1   | Clock mode select<br>• Single-system clock mode<br>• Dual-system clock mode                                 | Dual-system clock mode  | Changing by the switch on MCU board                                   |
| 2   | Low voltage detection reset*<br>• With low voltage detection reset<br>• Without low voltage detection reset | Specified by part number  | Changing by the switch on MCU board                                   |
| 3   | Oscillation stabilization wait time   | Fixed to oscillation stabilization wait time of $(2^{14}-2) / F_{CH}$ | Fixed to oscillation stabilization wait time of $(2^{14}-2) / F_{CH}$ |

\* : Refer to table below about clock mode select, low voltage detection reset, and reset output.

| Part number    | Clock mode select | Low voltage detection reset | Reset output |
|----------------|-------------------|-----------------------------|--------------|
| MB95F128H      | Dual-system       | No                          | Yes          |
| MB95F128T      |                   | Yes                         | Yes          |
| MB95FV100B-103 | Single-system     | No                          | Yes          |
|                |                   | Yes                         | Yes          |
|                | Dual-system       | No                          | Yes          |
|                |                   | Yes                         | Yes          |

## ■ ORDERING INFORMATION

| Part number                       | Package  | Remarks |
|-----------------------------------|--|---------|
| MB95F128HPFV<br>MB95F128TPFV      | 100-pin plastic LQFP<br>(FPT-100P-M05)                   |         |
| MB95F128HPF<br>MB95F128TPF        | 100-pin plastic QFP<br>(FPT-100P-M06)                    |         |
| MB2146-303<br>(MB95FV100B-103PBT) | MCU board<br>( 224-pin plastic PFBGA )<br>(BGA-224P-M08) |         |



# MB95120H Series

(Continued)

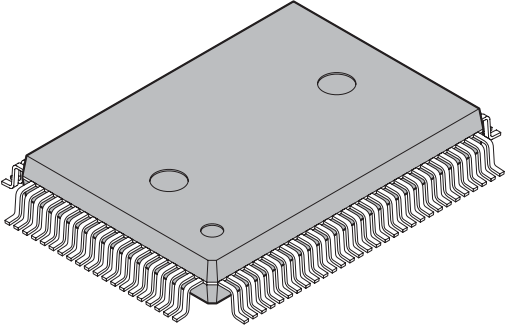
|  |                                |                     |
|--|--------------------------------|---------------------|
| <p style="text-align: center;">100-pin plastic QFP</p>  <p style="text-align: center;">(FPT-100P-M06)</p> | Lead pitch                     | 0.65 mm             |
|  | Package width × package length | 14.00 × 20.00 mm    |
|  | Lead shape                     | Gullwing            |
|  | Sealing method                 | Plastic mold        |
|  | Mounting height                | 3.35 mm MAX         |
|  | Code (Reference)               | P-QFP100-14×20-0.65 |
|  |                                |                     |

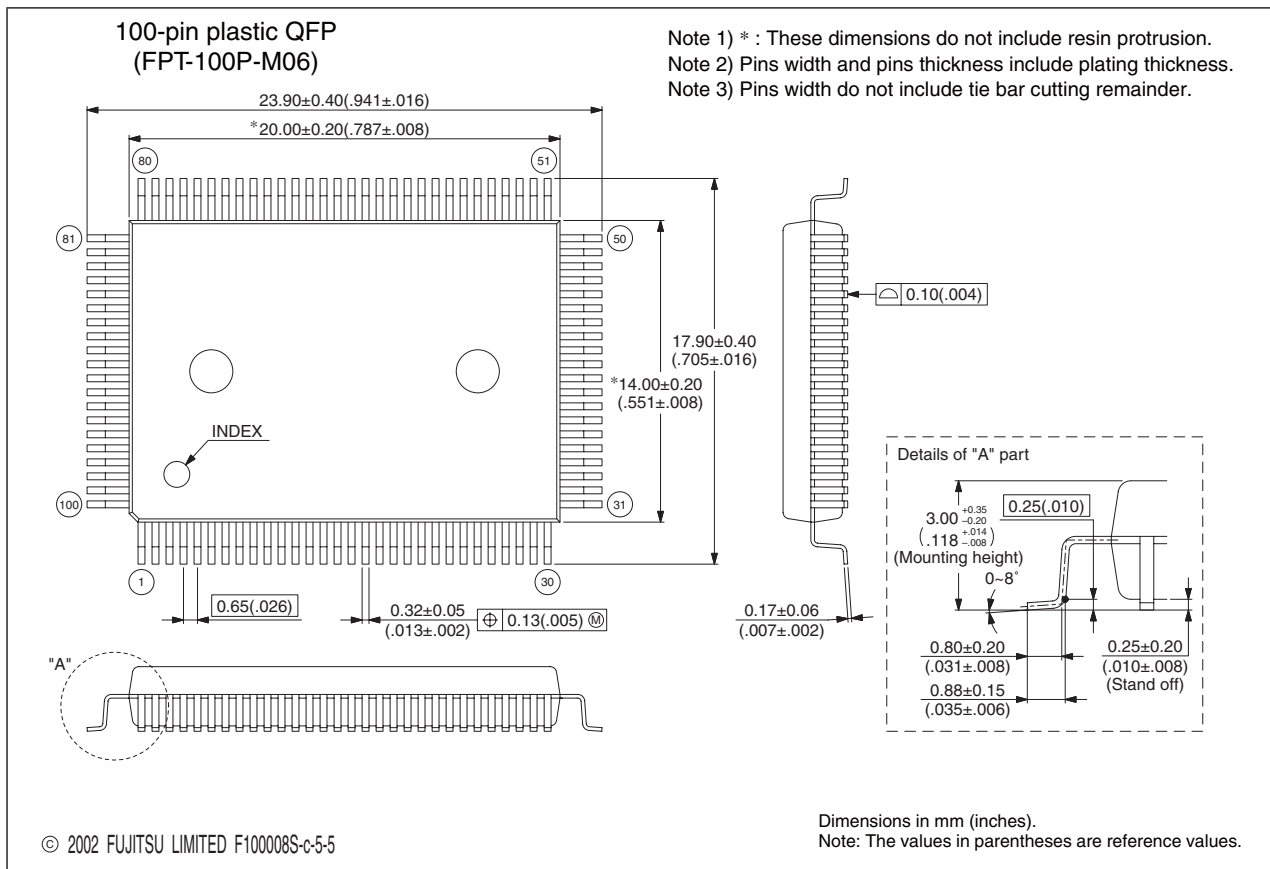

# MB95120H Series

The information for microcontroller supports is shown in the following homepage.  
<http://www.fujitsu.com/global/services/microelectronics/product/micom/support/index.html>

## FUJITSU LIMITED

All Rights Reserved.

The contents of this document are subject to change without notice. Customers are advised to consult with FUJITSU sales representatives before ordering.

The information, such as descriptions of function and application circuit examples, in this document are presented solely for the purpose of reference to show examples of operations and uses of Fujitsu semiconductor device; Fujitsu does not warrant proper operation of the device with respect to use based on such information. When you develop equipment incorporating the device based on such information, you must assume any responsibility arising out of such use of the information. Fujitsu assumes no liability for any damages whatsoever arising out of the use of the information.

Any information in this document, including descriptions of function and schematic diagrams, shall not be construed as license of the use or exercise of any intellectual property right, such as patent right or copyright, or any other right of Fujitsu or any third party or does Fujitsu warrant non-infringement of any third-party's intellectual property right or other right by using such information. Fujitsu assumes no liability for any infringement of the intellectual property rights or other rights of third parties which would result from the use of information contained herein.

The products described in this document are designed, developed and manufactured as contemplated for general use, including without limitation, ordinary industrial use, general office use, personal use, and household use, but are not designed, developed and manufactured as contemplated (1) for use accompanying fatal risks or dangers that, unless extremely high safety is secured, could have a serious effect to the public, and could lead directly to death, personal injury, severe physical damage or other loss (i.e., nuclear reaction control in nuclear facility, aircraft flight control, air traffic control, mass transport control, medical life support system, missile launch control in weapon system), or (2) for use requiring extremely high reliability (i.e., submersible repeater and artificial satellite).

Please note that Fujitsu will not be liable against you and/or any third party for any claims or damages arising in connection with above-mentioned uses of the products.

Any semiconductor devices have an inherent chance of failure. You must protect against injury, damage or loss from such failures by incorporating safety design measures into your facility and equipment such as redundancy, fire protection, and prevention of over-current levels and other abnormal operating conditions.

If any products described in this document represent goods or technologies subject to certain restrictions on export under the Foreign Exchange and Foreign Trade Law of Japan, the prior authorization by Japanese government will be required for export of those products from Japan.

Edited Business Promotion Dept.