

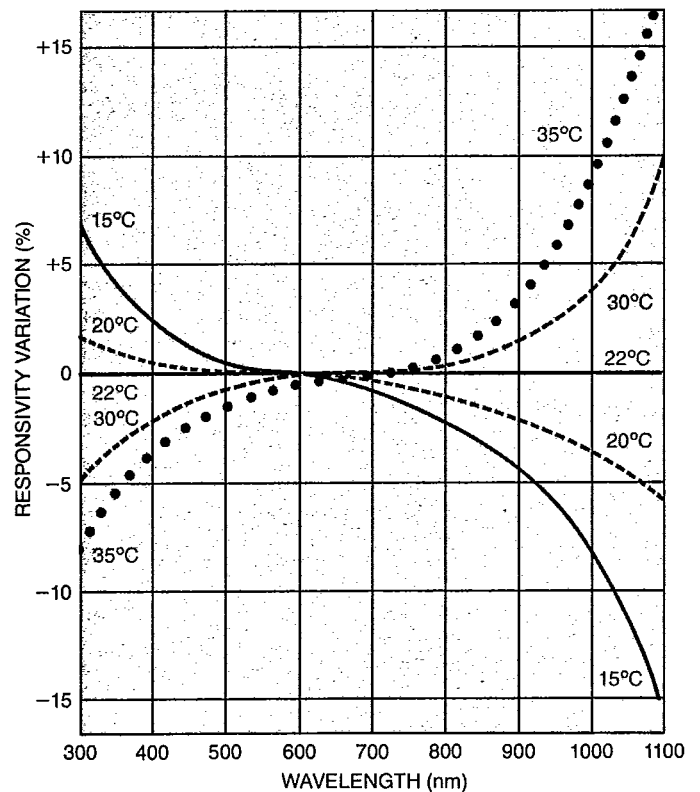

POSITION SENSING PHOTODIODES

	ACTIVE SURFACE		RECOM- MENDED MODE OF OPERATION	TYPICAL (1)	TYPICAL (1)	TYPICAL (1) (2)		TYPICAL (1)			TYPICAL (3) SOURCE RESISTAN
	AREA	DIMENSIONS		632.8nm	(1mm SPOT)	CENTRAL 25%	CENTRAL 75%	5V	10V	25V	
				mm ²	INCHES	A/W	± PERCENT	PERCENT		μA	
SPOT-2D	6.45	0.1x0.105	PV/PC	0.3	2	N/A		—	0.005	0.009	20
SPOT-4D	6.45	0.105x0.105	PV/PC	0.3	2	N/A		—	0.003	0.006	20
SPOT-9D	78	.394	PV/PC	0.3	2	N/A		—	0.010	0.030	20
LSC-5D	11.5	0.21x0.085	PV/PC	0.3	2	0.2	1.0	0.01	—	—	100
LSC-30D	122	1.18x0.16	PV/PC	0.3	2	0.2	1.0	0.01	—	—	10
LSC-4	258	0.1x4.0	PC	0.25	5	0.5	1.0	—	4.0	9.0	0.2
SC-4D	6.45	0.1x0.1	PV/PC	0.3	2	0.5	3.0	—	0.05	0.5	40
SC-10	100	0.394x0.394	PC	0.25	5	0.5	4.0	—	0.50	—	N/A
SC-10D	103	0.4x0.4	PV/PC	0.3	2	0.5	3.0	—	0.15	1.5	5
SC-25D	350	0.74x0.74	PV/PC	0.3	5	0.5	3.0	—	0.70	—	N/A
SC-50	1260	1.75 DIA.	PC	0.25	5	0.5	3.0	—	3.00	—	N/A

Diagram A
TEMPERATURE VARIATION
VS. SPECTRAL RESPONSE



Designer's Footnotes

1. Specifications are per element for spot series
2. Defined as maximum deviation from best straight line over the specified range expressed as a percentage of that range (for a normalized system)
3. Positioning resistance is defined as the resistance along an axis between the end contacts

General Information

- Maximum values are twice typical values shown
- T_A = 22°C for all specifications
- Rise time is a function of capacitance and varies 20% due to process variability
- Chip centering is within ±0.010" (0.762mm)
- Linear output within 5% throughout 9 decades
- Maximum power density is 10 mw/cm²
- See FIL brochure for plastic housed units

Information in this brochure is believed to be accurate and reliable, however, no responsibility is assumed by UDT for its use.

CE	(1) MINIMUM BREAKDOWN VOLTAGE			(1) CAPACITANCE			(1) TYPICAL RISE TIME (10%-90%, RL=50Ω)			(1) NEP	(1) (3) POSITIONING RESISTANCE	(1) MAXIMUM OUTPUT FOR 10% LINEARITY			TEMPERATURE RANGE	
	10μA	25μA	100μA	0V	10V	25V	5V	10V	25V	10V		0V	5V	10V	STORAGE	OPERA
	V	V	V	pf	pf	pf	ns	ns	ns	W/√Hz	KΩ	μA	μA	μA	°C	°C
	50	—	—	54	11	7	—	15	11	7x10 ⁻¹⁴	—	200	—	250	-55/+100	-25/-
	50	—	—	29	8	5	—	13	11	6x10 ⁻¹⁴	—	500	—	1000	-55/+100	-25/-
	—	50	—	200	62	40	—	30	15	10 ⁻¹³	—	500	—	1000	-55/+100	-25/-
	—	—	50	190	55	24	500	—	—	2x10 ⁻¹³	10	20	200	—	-55/+100	-25/-
	—	—	25	1470	—	—	7000	—	—	5x10 ⁻¹³	20	100	1000	—	-55/+100	-25/-
	—	50	—	—	1240	540	—	140000	80	10 ⁻¹²	200	—	—	10	-25/+75	-10/-
	—	25	—	100	27	17	—	70	—	10 ⁻¹¹	10	100	—	—	-55/+100	-25/-
	—	50	—	—	490	—	—	1500	—	10 ⁻¹¹	4	—	—	1000	-25/+75	-10/-
	—	25	—	1200	260	166	—	2000	—	10 ⁻¹¹	4	100	—	—	-55/+100	-25/-
	—	50	—	—	1420	—	—	5000	—	10 ⁻¹¹	2	—	—	1000	-25/+75	-10/-
	25	—	—	—	4800	—	—	15000	—	10 ⁻¹¹	1	—	—	1000	-25/+75	-10/-

Diagram B
RELATIVE CAPACITANCE VS.
REVERSE BIAS VOLTAGE

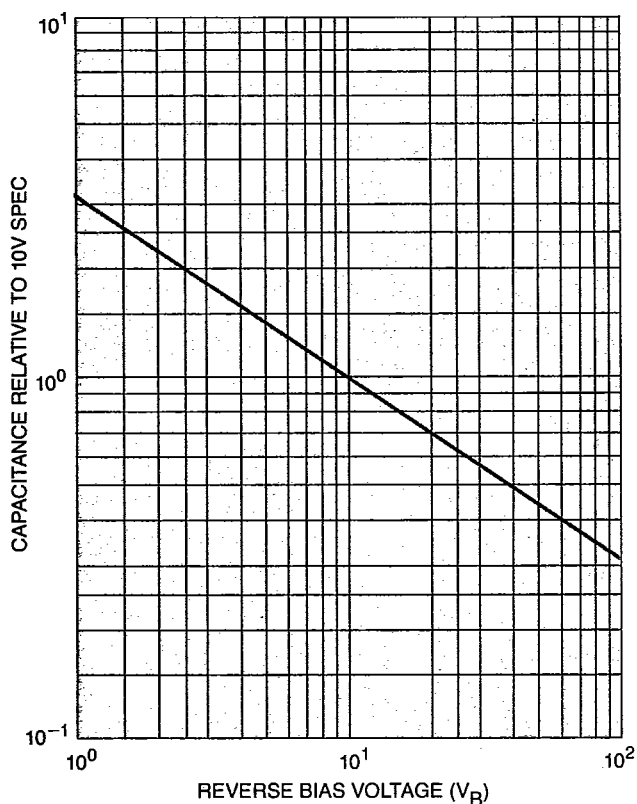

Diagram C
RELATIVE SOURCE RESISTANCE
VS. TEMPERATURE

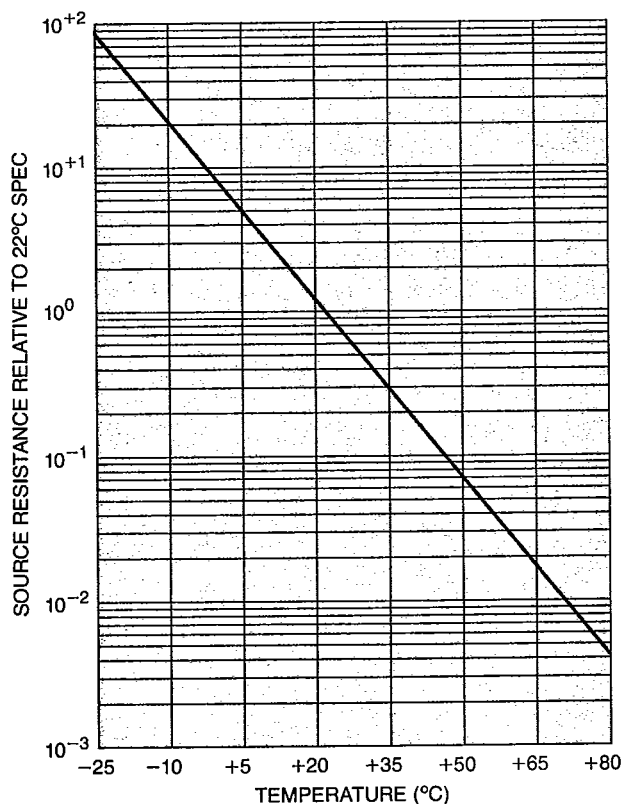
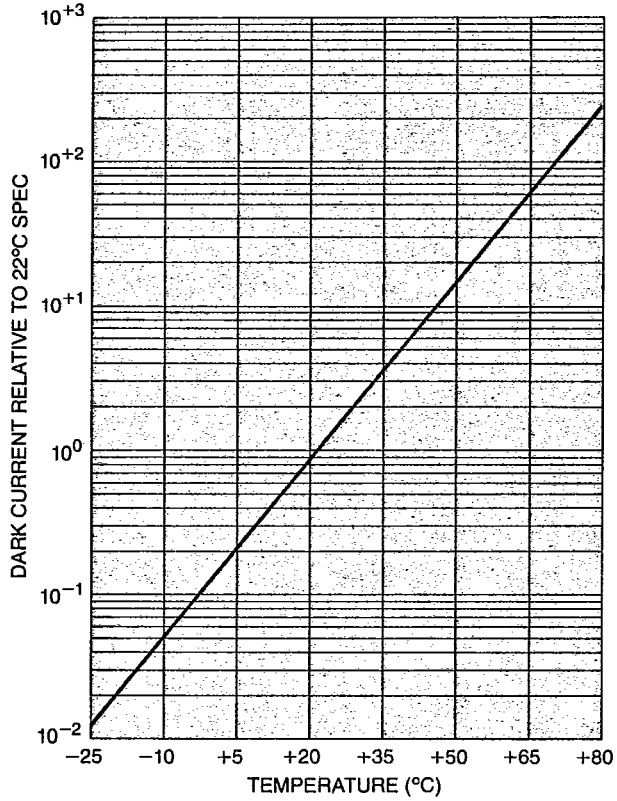
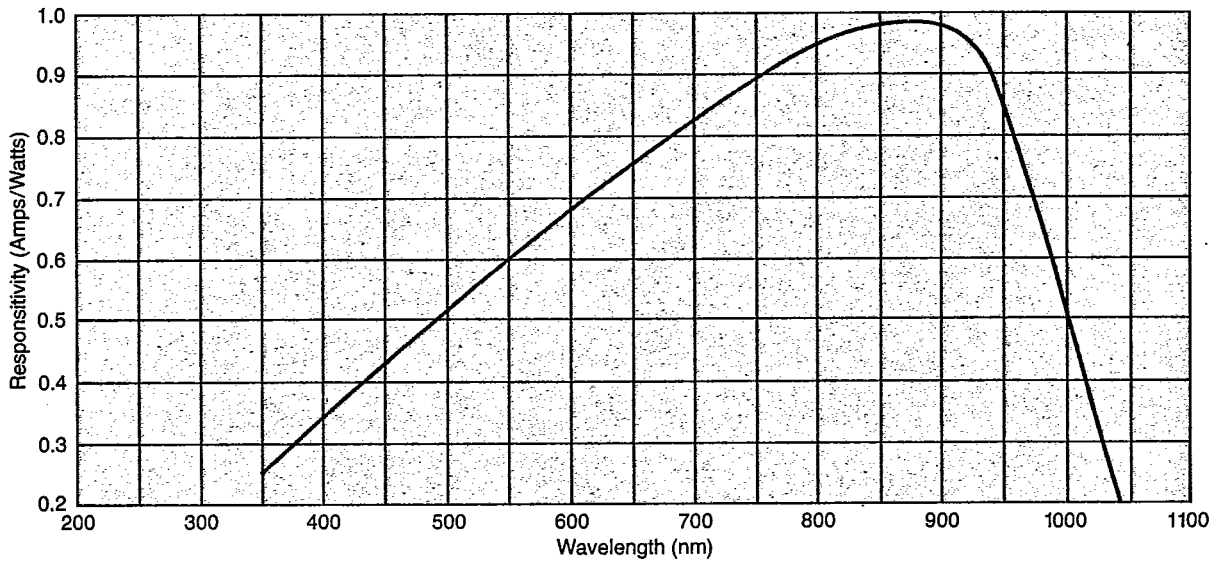

Diagram D
RELATIVE DARK CURRENT
VS. TEMPERATURE
(Diffused Series Only)



TEMPERATURE	FIELD OF VIEW
	DEGREES
-80	96
-80	96
-80	145
-80	60
-80	52
-55	45
-80	96
-55	160
-80	140
-55	155
-55	162

Diagram E
NORMALIZED SPECTRAL RESPONSE



POSITION SENSING INSTRUMENTATION

To fully utilize the capability of these sensors, appropriate electronics are required. UDT provides the necessary electronics in the form of building block amplifiers and complete position sensing instruments.

301 Series Amplifiers

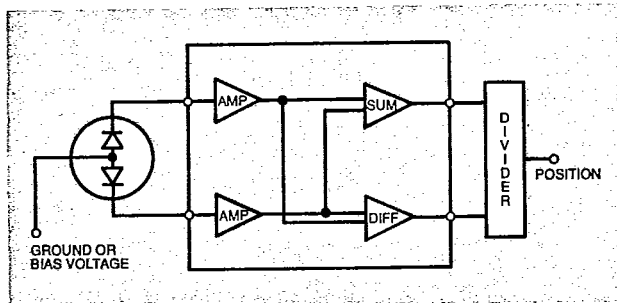

The input stages of the 301 are transimpedance amplifiers which provide gain and convert the detector output currents to proportional voltages. The output of each amp is fed to a sum and difference amplifier, such that the difference signal is proportional to spot intensity and position, the sum signal to intensity. Division of these two signals is necessary to obtain position only. This can be done with a commercially available analog divider or digitized and divided in a processor or data logger.

A single 301 is compatible with the SPOT and LSC series. Two amplifiers are required for the SC series.

431 System

The UDT Model 431 X-Y Optical Position Indicator is a stand-alone analog instrument with digital display. When interfaced with UDT lateral effect photodiodes or quadrant detectors, the Model 431 determines the location of the "Centroid" of a light spot incident on the photodetector in terms of its X and Y coordinates. This provides a unique solution to applications involving the measurement of vibration, rotation, straightness, angle, motion, alignment, and surface uniformity.

The Op-Eye system is a powerful, cost-effective remote optical position-sensing system. It is a computer peripheral which detects the presence and/or location of a reflective or self-luminous object within its field of view.

Systems are available for use with Apple II* computers and for computers and programmable calculators that have an RS-232C or IEEE-488 interface.

Highly accurate flatness, rotation, and parallelism can be measured with the UDT Model 1000 Autocolimator. Vibration, displacement and depth are measured with the OP-EYE and highly accurate centering or nulling with the 431 unit.

For complete details, application notes or assistance on the complete spectrum of optical non-contact measurements, please contact your local UDT representative or UDT directly.

Model 431 Circuit Diagram

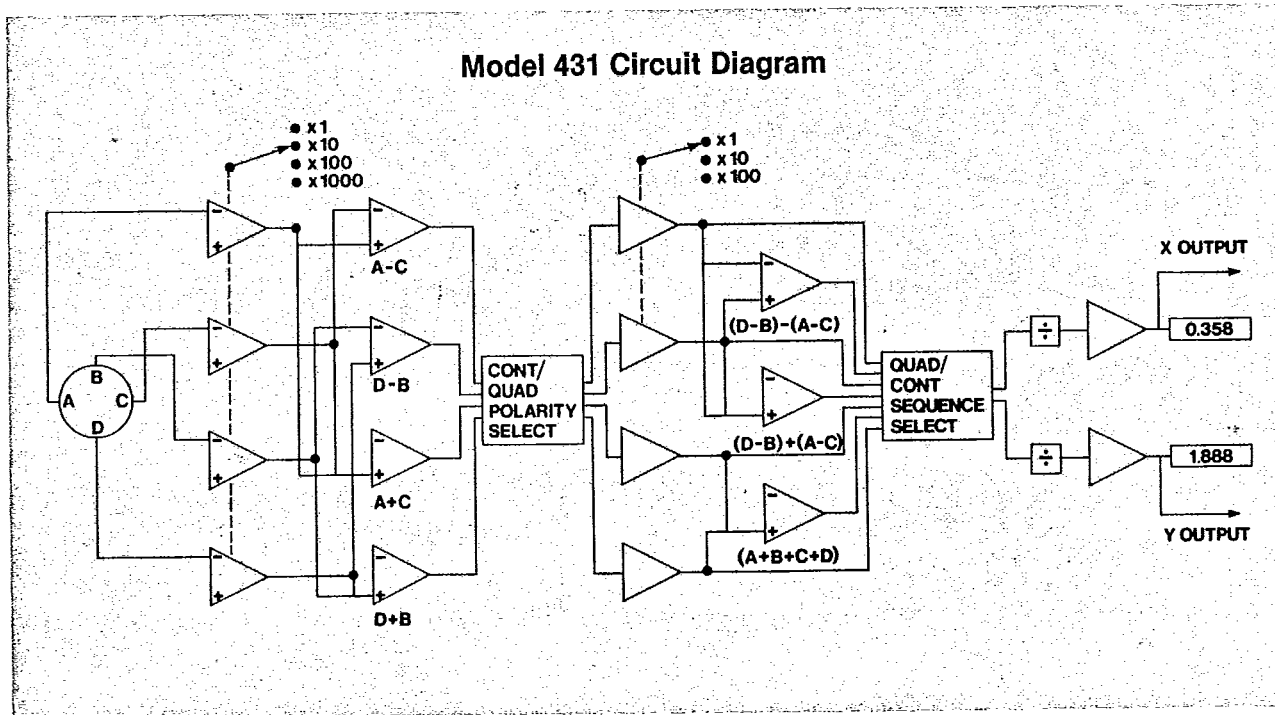

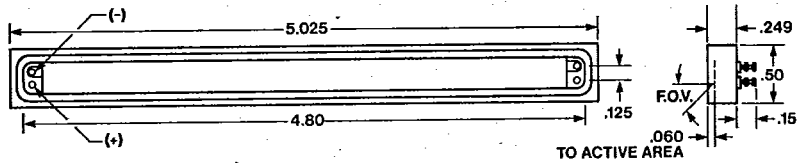

LSC/4

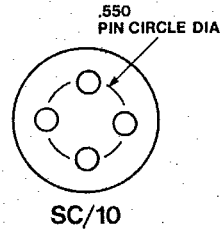

SC/10

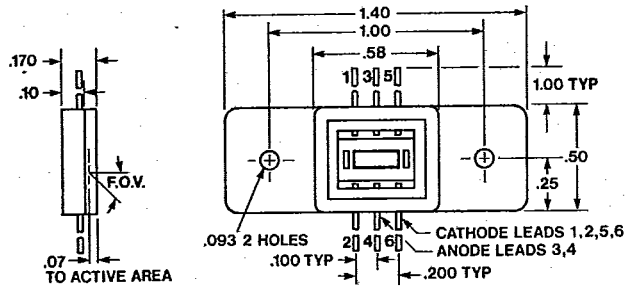
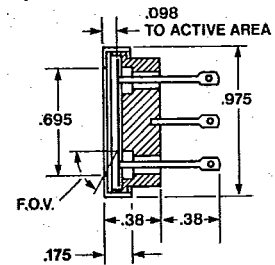

LSC/5D

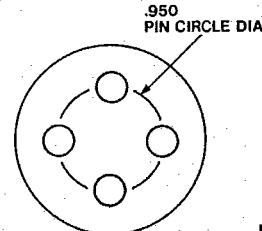

SC/25 D

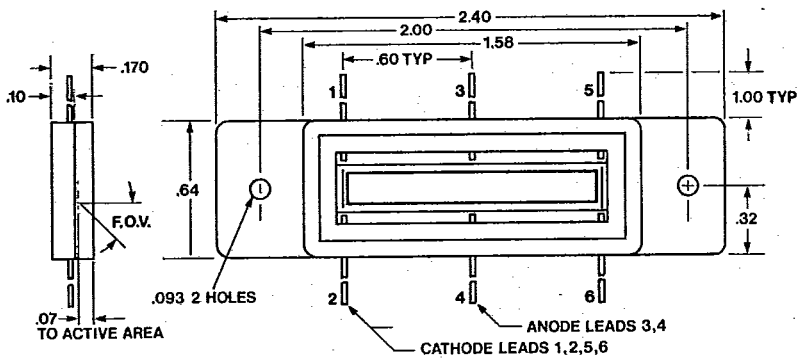
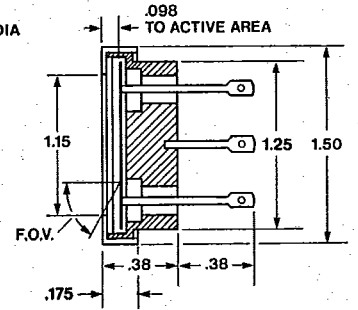

LSC/30D

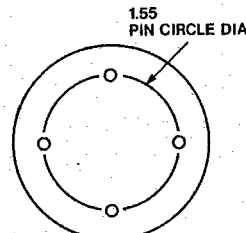

SC/50

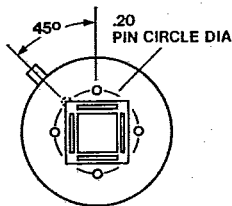
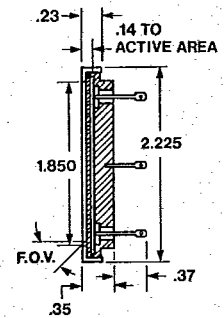

SC/4D

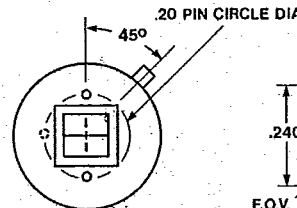
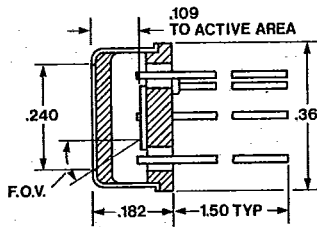

SPOT/2D and SPOT/4D

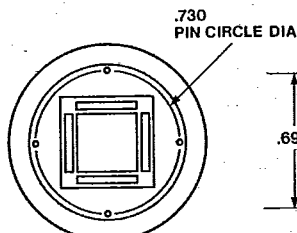
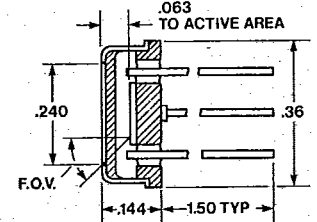

SC/10D

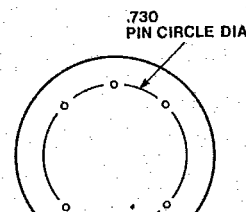
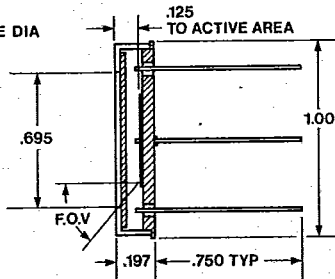

SPOT/9D

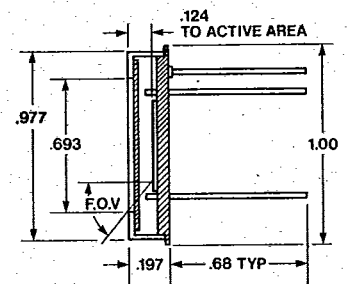

United Detector Technology

12525 Chadron Ave., Hawthorne, CA 90250 USA • Phone (213) 978-0516
 Telex Number 18-2458 • FAX (213) 644-1727 • Cable Address: SILDETECT, Hawthorne, California