

5512 Dual High-Performance Operational Amplifier

Product Specification

Military Communications and
Industrial Products

DESCRIPTION

The 5512 series of high-performance operational amplifier provides very good input characteristics. These amplifiers feature low input bias and voltage characteristics such as a 108 op amp with improved CMRR and a high differential input voltage limit achieved through the use of a bias cancellation and PNP input circuits with collector-to-emitter clamping. The output characteristics are like those of a 741 op amp with improved slew rate and drive capability yet have low supply quiescent current.

APPLICATIONS

- AC amplifiers
- RC active filters
- Transducer amplifiers
- DC gain block
- Battery operation
- Instrumentation amplifiers

FEATURES

- Low input bias $< \pm 20\text{nA}$
- Low input offset current $< \pm 20\text{nA}$
- Low input offset voltage $< 1\text{mV}$
- Low V_{OS} temperature drift $5\mu\text{V}/^\circ\text{C}$
- Low input bias temperature drift $40\text{pA}/^\circ\text{C}$
- Low input voltage noise $30\text{nV}/\sqrt{\text{Hz}}$
- Low supply current $1.5\text{mA}/\text{amp}$
- High slew rate $1.0\text{V}/\mu\text{s}$
- High CMRR 100dB
- High Input Impedance $100\text{M}\Omega$
- High PSRR 110dB
- High differential input voltage limit
- No cross-over distortion
- Indefinite output short-circuit protection
- Internally compensated for unity gain
- 600Ω drive capability

PIN CONFIGURATION

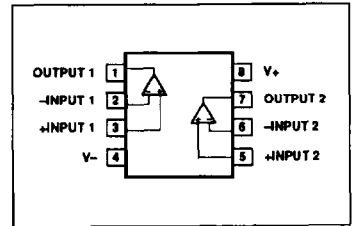

ORDERING INFORMATION

DESCRIPTION	ORDER CODE
8-Pin Ceramic DIP	5512/BPA

EQUIVALENT SCHEMATIC (Each Amplifier)

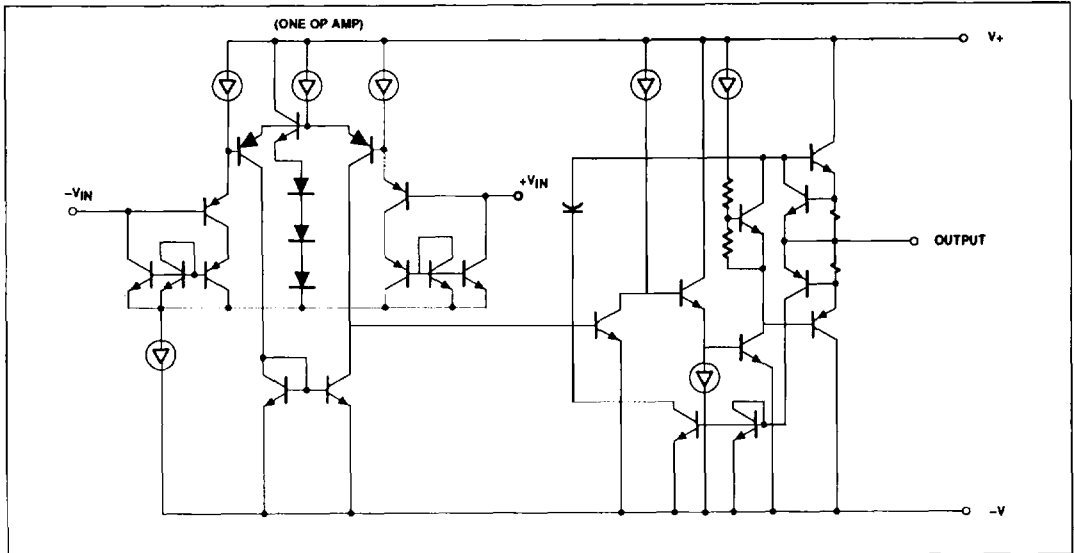

Dual High-Performance Operational Amplifier

5512

ABSOLUTE MAXIMUM RATINGS

SYMBOL	PARAMETER	RATING ¹	UNIT
V _{CC}	Supply voltage	±16	V
P _D	Power dissipation	500	mW
T _{STG}	Storage temperature range	-65 to +150	°C

DC ELECTRICAL PERFORMANCE CHARACTERISTICS V₊ = +15V, V₋ = -15V, unless otherwise specified.

SYMBOL	PARAMETER	TEST CONDITIONS	T _A = +25°C			T _A = -55°C, +125°C			UNIT
			Min	Typ	Max	Min	Typ	Max	
V _{IO}	Input offset voltage	R _S = 50Ω		0.7	2.0			3.0	mV
I _{IO}	Input offset current	R _S = 100kΩ		3.0	10.0			20.0	nA
I _{IB}	Input bias current	R _S = 100kΩ		3.0	10.0			20.0	nA
R _I	Input resistance differential			100.0					MΩ
V _{ICR}	Common mode voltage range		±13.5	±13.7		±13.0			V
CMRR	Input common-mode rejection ratio	V _I = ±13.5V	70.0	100.0					dB
		V _I = ±13.0V				70.0			dB
A _V	Large-signal voltage gain	R _L = 2kΩ, V _O = ±10V	50.0	200.0		25.0			V/mV
S.R.	Slew rate ²		0.6	1.0					V/μS
GBW	Small-signal unity gain bandwidth			3.0					MHz
θ _M	Phase margin			45.0					Degree
V _O	Output voltage swing	R _L = 2kΩ	±13.0	±13.5		±12.5			V
V _O	Output voltage swing	R _L = 600Ω	±10.0	±11.5		±7.5			V
I _{CC}	Power supply current			3.4	5.0			5.5	mA
P _{SRR}	Power supply rejection ratio		80.0	110.0		80.0			dB
CS	Amplifier to amplifier coupling	f = 1kHz to 20kHz		-120.0					dB
HD	Total harmonic distortion	f = 10kHz, V _O = 7V _{RMS}		0.01					%
E _N	Input noise voltage	f = 1kHz		30.0					nV/√Hz
I _N	Input noise current	f = 1kHz		0.2					pA/√Hz
I _{SC}	Output short-circuit current			40					mA

NOTE:

1. Operation beyond the limit of this table may impair the useful life of this device.
2. This parameter is guaranteed, but not tested.