



# ICS8731-01

## LOW SKEW, 1-TO-11 DIFFERENTIAL-TO-3.3V LVPECL CLOCK MULTIPLIER / ZERO DELAY BUFFER

### GENERAL DESCRIPTION

The ICS8731-01 is a low voltage, low skew, 1-to-11 Differential-to-3.3V LVPECL Clock Multiplier/Zero Delay Buffer. With output frequencies up to 700MHz the ICS8731-01 is targeted at high performance clock applications. Along with a fully integrated PLL the ICS8731-01 contains frequency configurable, differential outputs and external feedback inputs for multiplying clock frequencies and regenerating clocks with “zero delay”. Frequency multiplication is achieved by utilizing the separate feedback and clock output dividers. The value of the multiplier is determined by the ratio of the feedback divider, M, to the output divider, N. For multiplier values greater than 1, M must be greater than N. For multiplier values less than 1, M must be less than N. The zero delay mode is achieved with M and N at equal values. The divide values of the clock and feedback outputs are controlled by the DIV\_SEL0:2 and FB\_SEL0:1 inputs, respectively. The ICS8731-01 accepts any differential signal and translates it to differential 3.3V LVPECL output levels.

### FEATURES

- Eleven differential 3.3V LVPECL outputs
- Differential reference clock input pair
- REF\_CLK, nREF\_CLK pair can accept the following differential input levels: LVPECL, LVDS, LVHSTL, SSTL, HCSL
- Maximum output frequency: 700MHz
- Maximum reference clock input frequency: 200MHz
- VCO range: 250MHz - 700MHz
- Accepts any single-ended input signal with a resistor bias on nCLK input
- External feedback for zero delay capability
- Output skew: 70ps (maximum)
- Cycle-to-cycle jitter: 65ps (maximum)
- Full 3.3V operating supply
- 0°C to 70°C ambient operating temperature
- Available in both standard and lead-free RoHS compliant packages

### BLOCK DIAGRAM

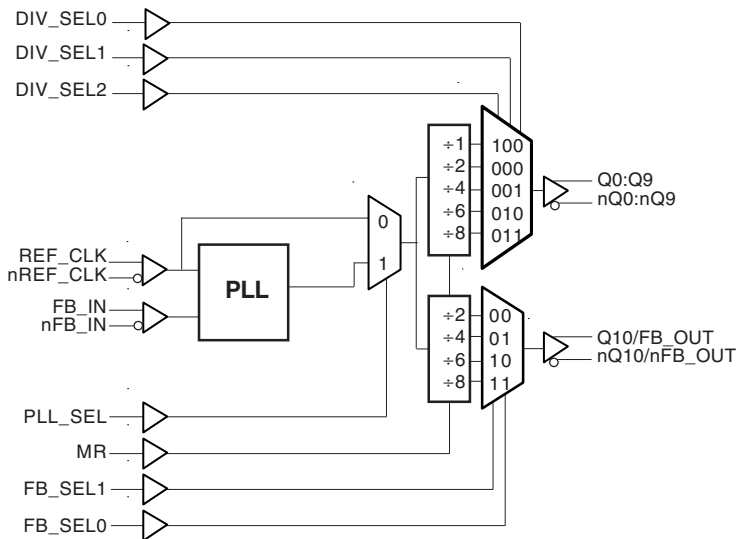

### PIN ASSIGNMENT

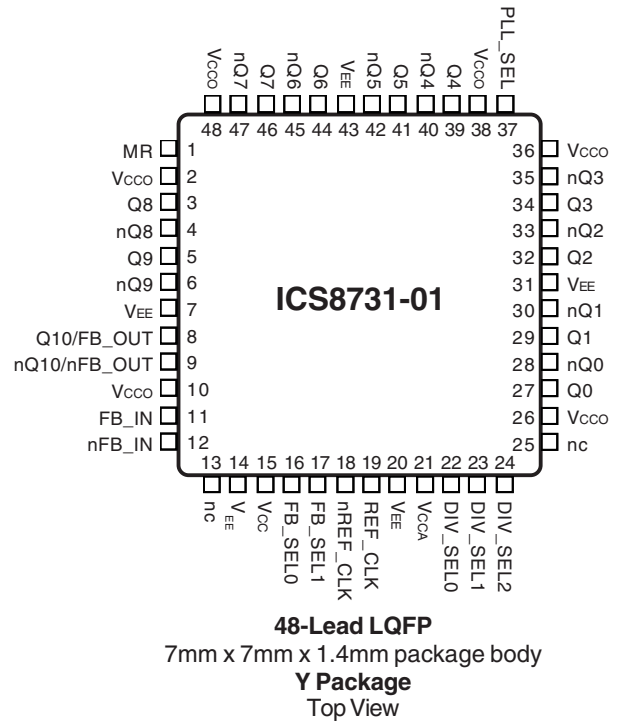



# ICS8731-01

LOW SKEW, 1-TO-11 DIFFERENTIAL-TO-3.3V LVPECL  
CLOCK MULTIPLIER / ZERO DELAY BUFFER

**TABLE 1. PIN DESCRIPTIONS**

| Number                      | Name                        | Type   |          | Description  |
|-----------------------------|-----------------------------|--------|----------|--|
| 1                           | MR                          | Input  | Pulldown | Active High Master Reset. When logic HIGH, the internal dividers are reset causing the true outputs, Qx, to go low and the inverted outputs nQx to go high. When logic LOW, the internal dividers and the outputs are enabled. LVCMOS / LVTTTL interface levels. |
| 2, 10,<br>26, 36,<br>38, 48 | V <sub>CCO</sub>            | Power  |          | Output supply pins.  |
| 3, 4,<br>5, 6               | Q8, nQ8,<br>Q9, nQ9         | Output |          | Differential output pairs.   |
| 7, 14, 20,<br>31, 43        | V <sub>EE</sub>             | Power  |          | Negative supply pins.  |
| 8,<br>9                     | Q10/FB_OUT,<br>nQ10/nFB_OUT | Output |          | Differential clock outputs.  |
| 11, 12                      | FB_IN, nFB_IN               | Input  | Pulldown | Feedback input to phase detector for generating clocks with "zero delay".  |
| 15                          | V <sub>CC</sub>             | Power  |          | Core supply pin.   |
| 16                          | FB_SEL0                     | Input  | Pulldown | Determines output divider for Q10/FB outputs (see Table 3). LVCMOS / LVTTTL interface levels.  |
| 17                          | FB_SEL1                     | Input  | Pulldown | Determines output divider for Q10/FB outputs (see Table 3). LVCMOS / LVTTTL interface levels.  |
| 18                          | nREF_CLK                    | Input  | Pullup   | Inverting differential clock input.  |
| 19                          | REF_CLK                     | Input  | Pulldown | Non-inverting differential clock input.  |
| 21                          | V <sub>CCA</sub>            | Power  |          | Analog supply pin.   |
| 22                          | DIV_SEL0,                   | Input  | Pulldown | Determines output divider values in Table 3. LVCMOS / LVTTTL interface levels.   |
| 23                          | DIV_SEL1                    | Input  | Pulldown | Determines output divider values in Table 3. LVCMOS / LVTTTL interface levels.   |
| 24                          | DIV_SEL2                    | Input  | Pulldown | Determines output divider values in Table 3. LVCMOS / LVTTTL interface levels.   |
| 13, 25                      | nc                          | Unused |          | No connect.  |
| 27, 28,<br>29, 30           | Q0, nQ0,<br>Q1, nQ1         | Output |          | Differential output pairs.   |
| 32, 33,<br>34, 35           | Q2, nQ2,<br>Q3, nQ3         | Output |          | Differential output pairs.   |
| 37                          | PLL_SEL                     | Input  | Pullup   | Selects between the PLL and reference clock as the input to the dividers. When LOW, selects reference clock. When HIGH, selects PLL. LVCMOS / LVTTTL interface levels.   |
| 39, 40,<br>41, 42           | Q4, nQ4,<br>Q5, nQ5         | Output |          | Differential output pairs.   |
| 44, 45,<br>46, 47           | Q6, nQ6,<br>Q7, nQ7         | Output |          | Differential output pairs.   |

NOTE: *Pullup* and *Pulldown* refer to internal input resistors. See Table 2, Pin Characteristics, for typical values.

**TABLE 2. PIN CHARACTERISTICS**

| Symbol                | Parameter               | Test Conditions | Minimum | Typical | Maximum | Units |
|-----------------------|-------------------------|-----------------|---------|---------|---------|-------|
| C <sub>IN</sub>       | Input Capacitance       |                 |         | 4       |         | pF    |
| R <sub>PULLUP</sub>   | Input Pullup Resistor   |                 |         | 51      |         | kΩ    |
| R <sub>PULLDOWN</sub> | Input Pulldown Resistor |                 |         | 51      |         | kΩ    |



**TABLE 3A. CONTROL INPUT FUNCTION TABLE FOR Q0:Q9 OUTPUTS**

| Inputs |         |          |          |          | Outputs        |
|--------|---------|----------|----------|----------|----------------|
| MR     | PLL_SEL | DIV_SEL2 | DIV_SEL1 | DIV_SEL0 | Q0:Q9, nQ0:nQ9 |
| 1      | X       | X        | X        | X        | Low            |
| 0      | 1       | 1        | 0        | 0        | fVCO/1         |
| 0      | 1       | 0        | 0        | 0        | fVCO/2         |
| 0      | 1       | 0        | 0        | 1        | fVCO/4         |
| 0      | 1       | 0        | 1        | 0        | fVCO/6         |
| 0      | 1       | 0        | 1        | 1        | fVCO/8         |
| 0      | 0       | 1        | 0        | 0        | fREF_CLK/1     |
| 0      | 0       | 0        | 0        | 0        | fREF_CLK/2     |
| 0      | 0       | 0        | 0        | 1        | fREF_CLK/4     |
| 0      | 0       | 0        | 1        | 0        | fREF_CLK/6     |
| 0      | 0       | 0        | 1        | 1        | fREF_CLK/8     |

**TABLE 3B. CONTROL INPUT FUNCTION TABLE FOR Q10/FB**

| Inputs |         |         |         | Outputs         |
|--------|---------|---------|---------|-----------------|
| MR     | PLL_SEL | FB_SEL1 | FB_SEL0 | Q10/FB, nQ10/FB |
| 1      | X       | X       | X       | Low             |
| 0      | 1       | 0       | 0       | fVCO/2          |
| 0      | 1       | 0       | 1       | fVCO/4          |
| 0      | 1       | 1       | 0       | fVCO/6          |
| 0      | 1       | 1       | 1       | fVCO/8          |
| 0      | 0       | 0       | 0       | fREF_CLK/2      |
| 0      | 0       | 0       | 1       | fREF_CLK/4      |
| 0      | 0       | 1       | 0       | fREF_CLK/6      |
| 0      | 0       | 1       | 1       | fREF_CLK/8      |

**TABLE 3C. Qx OUTPUT FREQUENCY W/FB\_IN = Q10/FB**

| Inputs |         |         |                               |               | fVCO         |              |
|--------|---------|---------|-------------------------------|---------------|--------------|--------------|
| FB_IN  | FB_SEL1 | FB_SEL0 | Q10/FB<br>Output Divider Mode | REF_CLK (MHz) |              | (NOTE 1)     |
|        |         |         |                               | Minimum       | Maximum      |              |
| Q10/FB | 0       | 0       | ÷2                            | 125           | 200 (NOTE 2) | fREF_CLK x 2 |
| Q10/FB | 0       | 1       | ÷4                            | 62.5          | 175          | fREF_CLK x 4 |
| Q10/FB | 1       | 0       | ÷6                            | 41.67         | 116.67       | fREF_CLK x 6 |
| Q10/FB | 1       | 1       | ÷8                            | 31.25         | 87.5         | fREF_CLK x 8 |

NOTE 1: VCO frequency range is 250MHz to 700MHz.

NOTE 2: The maximum input frequency that the phase defector can accept is 200MHz.



# ICS8731-01

## LOW SKEW, 1-TO-11 DIFFERENTIAL-TO-3.3V LVPECL CLOCK MULTIPLIER / ZERO DELAY BUFFER

### ABSOLUTE MAXIMUM RATINGS

|  |                          |
|--|--------------------------|
| Supply Voltage, $V_{CC}$                 | 4.6V                     |
| Inputs, $V_I$                            | -0.5V to $V_{CC} + 0.5V$ |
| Outputs, $I_O$                           |                          |
| Continuous Current                       | 50mA                     |
| Surge Current                            | 100mA                    |
| Package Thermal Impedance, $\theta_{JA}$ | 47.9°C/W (0 lfpm)        |
| Storage Temperature, $T_{STG}$           | -65°C to 150°C           |

NOTE: Stresses beyond those listed under Absolute Maximum Ratings may cause permanent damage to the device. These ratings are stress specifications only. Functional operation of product at these conditions or any conditions beyond those listed in the *DC Characteristics* or *AC Characteristics* is not implied. Exposure to absolute maximum rating conditions for extended periods may affect product reliability.

**TABLE 4A. POWER SUPPLY DC CHARACTERISTICS,  $V_{CC} = V_{CCA} = V_{CCO} = 3.3V \pm 5\%$ ,  $T_A = 0^\circ C$  TO  $70^\circ C$**

| Symbol    | Parameter             | Test Conditions | Minimum | Typical | Maximum | Units |
|-----------|-----------------------|-----------------|---------|---------|---------|-------|
| $V_{CC}$  | Core Supply Voltage   |                 | 3.135   | 3.3     | 3.465   | V     |
| $V_{CCA}$ | Analog Supply Voltage |                 | 3.135   | 3.3     | 3.465   | V     |
| $V_{CCO}$ | Output Supply Voltage |                 | 3.135   | 3.3     | 3.465   | V     |
| $I_{EE}$  | Power Supply Current  |                 |         |         | 195     | mA    |
| $I_{CCA}$ | Analog Supply Current |                 |         |         | 15      | mA    |

**TABLE 4B. LVCMOS/LVTTL DC CHARACTERISTICS,  $V_{CC} = V_{CCA} = V_{CCO} = 3.3V \pm 5\%$ ,  $T_A = 0^\circ C$  TO  $70^\circ C$**

| Symbol   | Parameter          | Test Conditions   | Minimum                              | Typical | Maximum        | Units   |
|----------|--------------------|---|--------------------------------------|---------|----------------|---------|
| $V_{IH}$ | Input High Voltage | PLL_SEL, DIV_SEL0, DIV_SEL1, DIV_SEL2, FB_SEL0, FB_SEL1, MR | 2                                    |         | $V_{CC} + 0.3$ | V       |
| $V_{IL}$ | Input Low Voltage  | PLL_SEL, DIV_SEL0, DIV_SEL1, DIV_SEL2, FB_SEL0, FB_SEL1, MR | -0.3                                 |         | 0.8            | V       |
| $I_{IH}$ | Input High Current | DIV_SEL0, DIV_SEL1, DIV_SEL2, MR, FB_SEL0, FB_SEL1          | $V_{CC} = V_{IN} = 3.465V$           |         | 150            | $\mu A$ |
|          |                    | PLL_SEL   | $V_{CC} = V_{IN} = 3.465V$           |         | 5              | $\mu A$ |
| $I_{IL}$ | Input Low Current  | DIV_SEL0, DIV_SEL1, DIV_SEL2, MR, FB_SEL0, FB_SEL1          | $V_{CC} = 3.465V$ ,<br>$V_{IN} = 0V$ | -5      |                | $\mu A$ |
|          |                    | PLL_SEL   | $V_{CC} = 3.465V$ ,<br>$V_{IN} = 0V$ | -150    |                | $\mu A$ |



# ICS8731-01

## LOW SKEW, 1-TO-11 DIFFERENTIAL-TO-3.3V LVPECL CLOCK MULTIPLIER / ZERO DELAY BUFFER

**TABLE 4C. DIFFERENTIAL DC CHARACTERISTICS,  $V_{CC} = V_{CCA} = V_{CCO} = 3.3V \pm 5\%$ ,  $T_A = 0^\circ C$  TO  $70^\circ C$**

| Symbol    | Parameter                            | Test Conditions  | Minimum                        | Typical | Maximum         | Units   |
|-----------|--------------------------------------|------------------|--------------------------------|---------|-----------------|---------|
| $I_{IH}$  | Input High Current                   | REF_CLK, FB_IN   | $V_{CC} = V_{IN} = 3.465V$     |         | 150             | $\mu A$ |
|           |                                      | nREF_CLK, nFB_IN | $V_{CC} = V_{IN} = 3.465V$     |         | 5               | $\mu A$ |
| $I_{IL}$  | Input Low Current                    | REF_CLK, FB_IN   | $V_{CC} = 3.465V, V_{IN} = 0V$ | -5      |                 | $\mu A$ |
|           |                                      | nREF_CLK, nFB_IN | $V_{CC} = 3.465V, V_{IN} = 0V$ | -150    |                 | $\mu A$ |
| $V_{PP}$  | Peak-to-Peak Input Voltage           |                  | 0.15                           |         | 1.3             | V       |
| $V_{CMR}$ | Common Mode Input Voltage; NOTE 1, 2 |                  | $V_{EE} + 0.5$                 |         | $V_{CC} - 0.85$ | V       |

NOTE 1: For single ended applications, the maximum input voltage for REF\_CLK, nREF\_CLK and FB\_IN, nFB\_IN is  $V_{CC} + 0.3V$ .

NOTE 2: Common mode voltage is defined as  $V_{IH}$ .

**TABLE 4D. LVPECL DC CHARACTERISTICS,  $V_{CC} = V_{CCA} = V_{CCO} = 3.3V \pm 5\%$ ,  $T_A = 0^\circ C$  TO  $70^\circ C$**

| Symbol      | Parameter                         | Test Conditions | Minimum         | Typical | Maximum         | Units |
|-------------|-----------------------------------|-----------------|-----------------|---------|-----------------|-------|
| $V_{OH}$    | Output High Voltage; NOTE 1       |                 | $V_{CCO} - 1.4$ |         | $V_{CCO} - 0.9$ | V     |
| $V_{OL}$    | Output Low Voltage; NOTE 1        |                 | $V_{CCO} - 2.0$ |         | $V_{CCO} - 1.7$ | V     |
| $V_{SWING}$ | Peak-to-Peak Output Voltage Swing |                 | 0.6             |         | 1.0             | V     |

NOTE 1: Outputs terminated with  $50\Omega$  to  $V_{CCO} - 2V$ .

**TABLE 5. PLL INPUT REFERENCE CHARACTERISTICS,  $V_{CC} = V_{CCA} = V_{CCO} = 3.3V \pm 5\%$ ,  $T_A = 0^\circ C$  TO  $70^\circ C$**

| Symbol    | Parameter                 | Test Conditions | Minimum | Typical | Maximum | Units |
|-----------|---------------------------|-----------------|---------|---------|---------|-------|
| $f_{REF}$ | Input Reference Frequency |                 |         |         | 200     | MHz   |

**TABLE 6. AC CHARACTERISTICS,  $V_{CC} = V_{CCA} = V_{CCO} = 3.3V \pm 5\%$ ,  $T_A = 0^\circ C$  TO  $70^\circ C$**

| Symbol         | Parameter                     | Test Conditions  | Minimum | Typical | Maximum | Units |
|----------------|-------------------------------|--|---------|---------|---------|-------|
| $f_{MAX}$      | Output Frequency              |  |         |         | 700     | MHz   |
| $t_{PD}$       | Propagation Delay; NOTE 1     | PLL_SEL = 0V, $f \leq 450MHz$                              | 4.0     |         | 5.5     | ns    |
| $t(\emptyset)$ | Static Phase Offset; NOTE 2   | PLL_SEL = 3.3V,<br>DIV_SEL[2:0] = 000,<br>FB_SEL[1:0] = 00 | 50      |         | 150     | ps    |
| $t_{sk(o)}$    | Output Skew; NOTE 3, 4        |  |         |         | 70      | ps    |
| $f_{jit(cc)}$  | Cycle-to-Cycle Jitter; NOTE 4 |  |         |         | 65      | ps    |
| $t_L$          | PLL Lock Time                 |  |         |         | 1       | ms    |
| $t_R / t_F$    | Output Rise/Fall Time         | 20% to 80%   | 300     |         | 700     | ps    |
| odc            | Output Duty Cycle             | $f \leq 300MHz$  | 45      |         | 55      | %     |

All parameters measured at  $f_{MAX}$  unless noted otherwise.

NOTE 1: Measured from the differential input crossing point to the differential output crossing point.

NOTE 2: Defined as the time difference between the input reference clock and the average feedback input signal when the PLL is locked and the input reference frequency is stable.

NOTE 3: Defined as skew between outputs at the same supply voltages and with equal load conditions. Measured at the output differential cross points.

NOTE 4: This parameter is defined in accordance with JEDEC Standard 65.

## PARAMETER MEASUREMENT INFORMATION

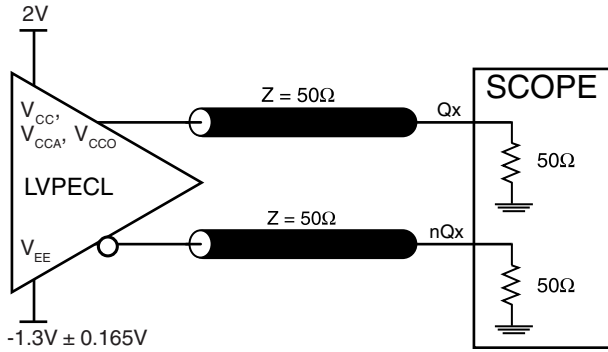

**3.3V OUTPUT LOAD AC TEST CIRCUIT**

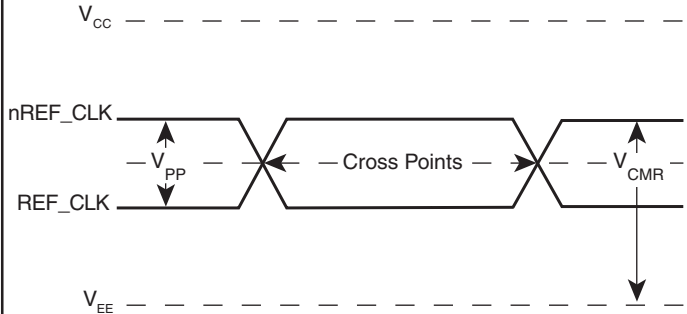

**DIFFERENTIAL INPUT LEVEL**

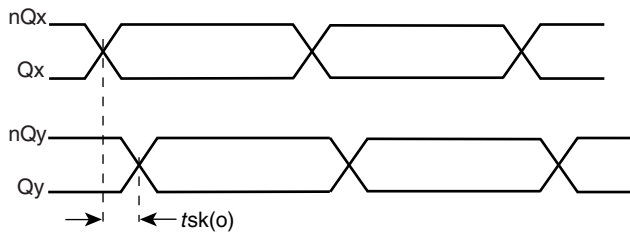

**OUTPUT SKEW**

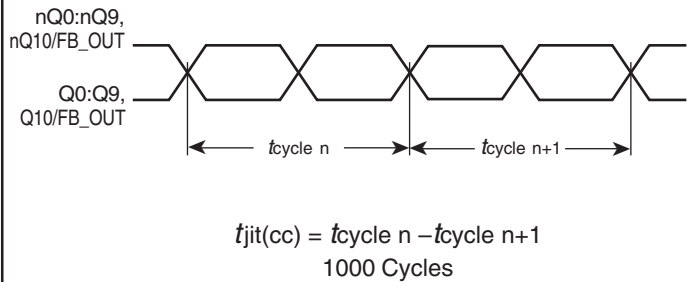

**CYCLE-TO-CYCLE JITTER**

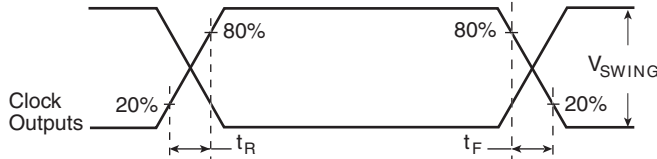

**OUTPUT RISE/FALL TIME**

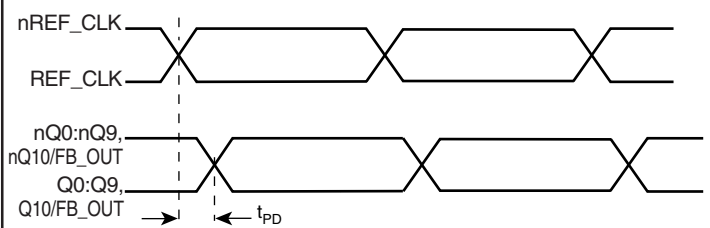

**PROPAGATION DELAY**

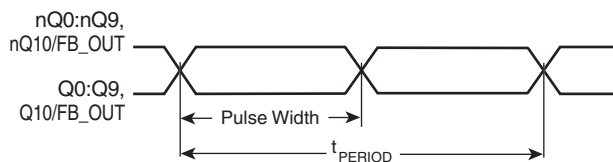

$$odc = \frac{t_{PW}}{t_{PERIOD}}$$

**OUTPUT DUTY CYCLE/PULSE WIDTH/PERIOD**

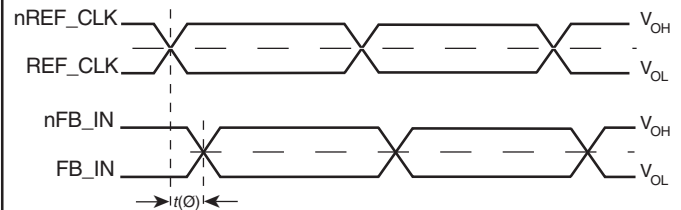

$$t(\emptyset)_{mean} = \text{Static Phase Offset}$$

(where  $t(\emptyset)$  is any random sample, and  $t(\emptyset)_{mean}$  is the average of the sampled cycles measured on controlled edges)

**STATIC PHASE OFFSET**

## APPLICATION INFORMATION

### POWER SUPPLY FILTERING TECHNIQUES

As in any high speed analog circuitry, the power supply pins are vulnerable to random noise. The ICS8731-01 provides separate power supplies to isolate any high switching noise from the outputs to the internal PLL.  $V_{CC}$ ,  $V_{CCA}$ , and  $V_{CCO}$  should be individually connected to the power supply plane through vias, and bypass capacitors should be used for each pin. To achieve optimum jitter performance, power supply isolation is required. *Figure 1* illustrates how a  $10\Omega$  resistor along with a  $10\mu\text{F}$  and a  $.01\mu\text{F}$  bypass capacitor should be connected to each  $V_{CCA}$  pin.

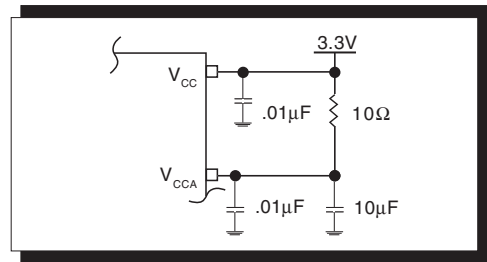
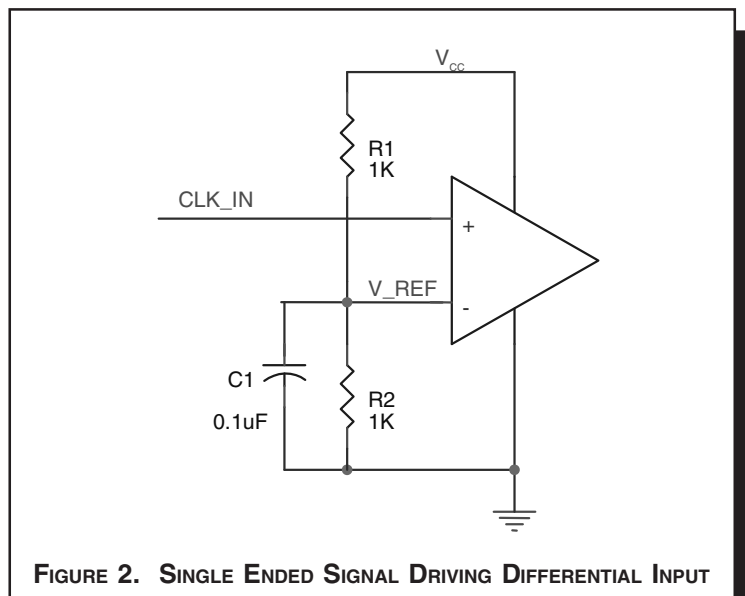

**FIGURE 1. POWER SUPPLY FILTERING**

### WIRING THE DIFFERENTIAL INPUT TO ACCEPT SINGLE ENDED LEVELS

*Figure 2* shows how the differential input can be wired to accept single ended levels. The reference voltage  $V_{REF} = V_{CC}/2$  is generated by the bias resistors R1, R2 and C1. This bias circuit should be located as close as possible to the input pin. The ratio

of R1 and R2 might need to be adjusted to position the  $V_{REF}$  in the center of the input voltage swing. For example, if the input clock swing is only 2.5V and  $V_{CC} = 3.3\text{V}$ ,  $V_{REF}$  should be 1.25V and  $R2/R1 = 0.609$ .

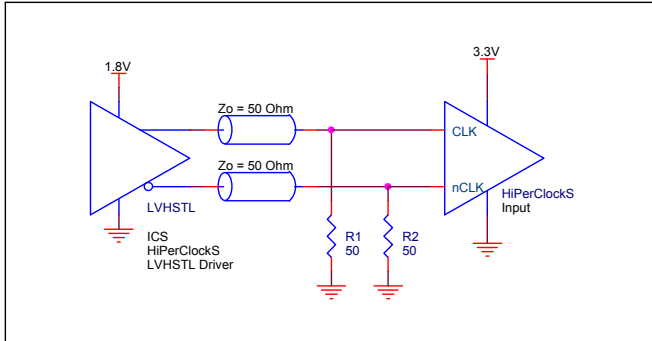

**FIGURE 2. SINGLE ENDED SIGNAL DRIVING DIFFERENTIAL INPUT**

### DIFFERENTIAL CLOCK INPUT INTERFACE

The REF\_CLK /nREF\_CLK accepts LVDS, LVPECL, LVHSTL, SSTL, HCSL and other differential signals. Both  $V_{SWING}$  and  $V_{OH}$  must meet the  $V_{PP}$  and  $V_{CMR}$  input requirements. Figures 3A to 3D show interface examples for the REF\_CLK/nREF\_CLK input driven by the most common driver types. The input interfaces suggested here are

examples only. Please consult with the vendor of the driver component to confirm the driver termination requirements. For example in *Figure 3A*, the input termination applies for LVHSTL drivers. If you are using an LVHSTL driver from another vendor, use their termination recommendation.



**FIGURE 3A. REF\_CLK/nREF\_CLK INPUT DRIVEN BY LVHSTL DRIVER**

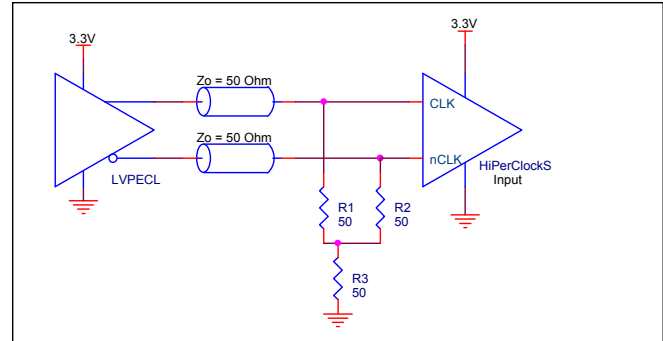

**FIGURE 3B. REF\_CLK/nREF\_CLK INPUT DRIVEN BY 3.3V LVPECL DRIVER**

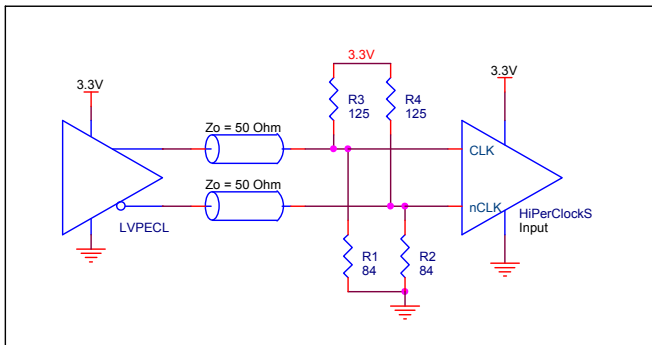

**FIGURE 3C. REF\_CLK/nREF\_CLK INPUT DRIVEN BY 3.3V LVPECL DRIVER**

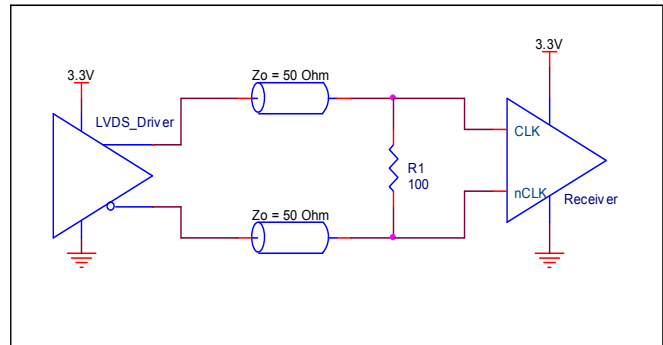

**FIGURE 3D. REF\_CLK/nREF\_CLK INPUT DRIVEN BY 3.3V LVDS DRIVER**



### RECOMMENDATIONS FOR UNUSED INPUT AND OUTPUT PINS

#### INPUTS:

##### LVC MOS CONTROL PINS:

All control pins have internal pull-ups or pull-downs; additional resistance is not required but can be added for additional protection. A 1kΩ resistor can be used.

#### OUTPUTS:

##### LVPECL OUTPUT

All unused LVPECL outputs can be left floating. We recommend that there is no trace attached. Both sides of the differential output pair should either be left floating or terminated.

### TERMINATION FOR LVPECL OUTPUTS

The clock layout topology shown below is a typical termination for LVPECL outputs. The two different layouts mentioned are recommended only as guidelines.

FOUT and nFOUT are low impedance follower outputs that generate ECL/LVPECL compatible outputs. Therefore, terminating resistors (DC current path to ground) or current sources must be used for functionality. These outputs are designed to drive 50Ω transmission lines. Matched imped-

ance techniques should be used to maximize operating frequency and minimize signal distortion. *Figures 4A and 4B* show two different layouts which are recommended only as guidelines. Other suitable clock layouts may exist and it would be recommended that the board designers simulate to guarantee compatibility across all printed circuit and clock component process variations.

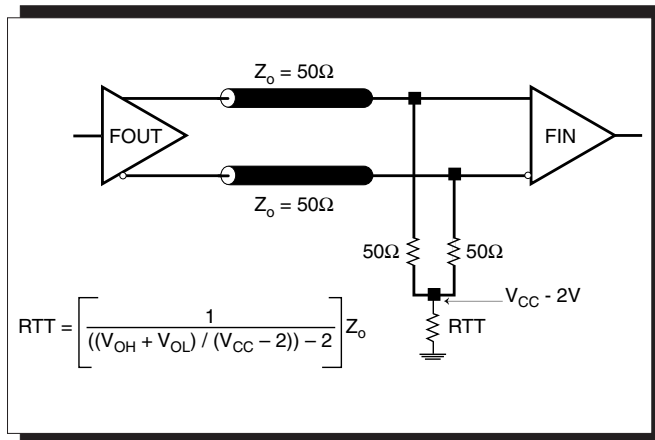

FIGURE 4A. LVPECL OUTPUT TERMINATION

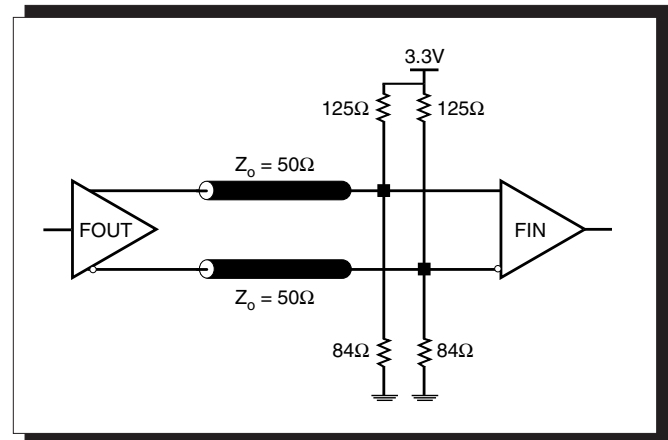

FIGURE 4B. LVPECL OUTPUT TERMINATION



# ICS8731-01

## LOW SKEW, 1-TO-11 DIFFERENTIAL-TO-3.3V LVPECL CLOCK MULTIPLIER / ZERO DELAY BUFFER

### SCHEMATIC EXAMPLE

Figure 5 shows an application schematic example of the ICS8731-01. This schematic provides examples of input and output handling. The input can accept various types of differential signal. This example shows the ICS8731-01 input driven by a 3.3V LVPECL driver. Additional examples for the input driven by other types of drivers are shown in the application section of

this data sheet. The ICS8731-01 outputs are LVPECL driver. In this example, we assume the traces are long transmission line and the receiver is high input impedance without built-in matched load. An example of 3.3V LVPECL termination is shown in this schematic. Additional termination approaches are shown in the LVPECL Termination Application Note.

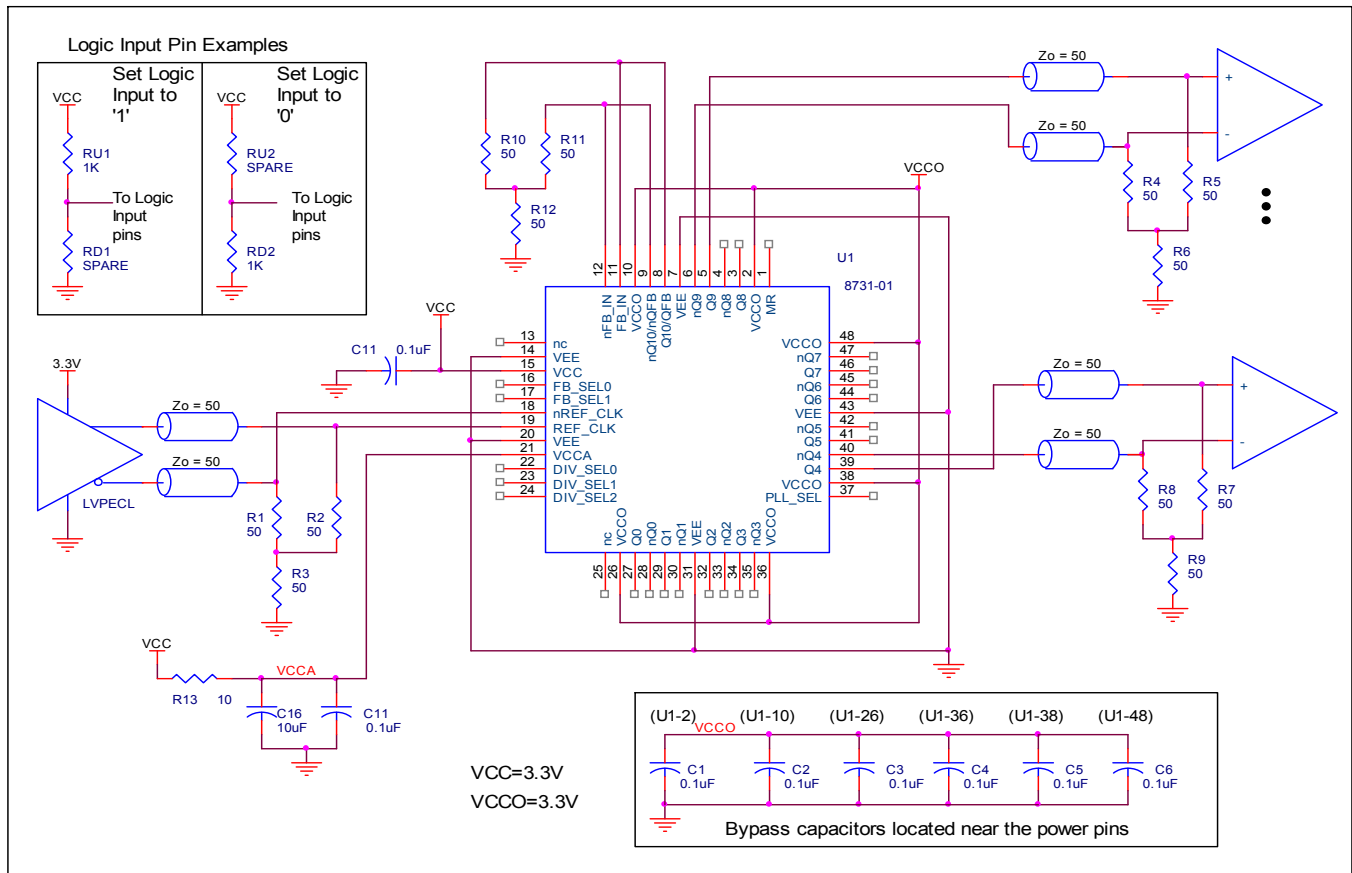

FIGURE 5. APPLICATION SCHEMATIC EXAMPLE



## POWER CONSIDERATIONS

This section provides information on power dissipation and junction temperature for the ICS8731-01. Equations and example calculations are also provided.

### 1. Power Dissipation.

The total power dissipation for the ICS8731-01 is the sum of the core power plus the power dissipated in the load(s). The following is the power dissipation for  $V_{CC} = 3.3V + 5\% = 3.465V$ , which gives worst case results.

**NOTE:** Please refer to Section 3 for details on calculating power dissipated in the load.

- Power (core)<sub>MAX</sub> =  $V_{CC\_MAX} * I_{EE\_MAX} = 3.465V * 195mA = 675.67mW$
- Power (outputs)<sub>MAX</sub> = **30mW/Loaded Output pair**  
 If all outputs are loaded, the total power is  $11 * 30mW = 330mW$

**Total Power**<sub>MAX</sub> (3.465V, with all outputs switching) =  $675.67mW + 330mW = 1005.67mW$

### 2. Junction Temperature.

Junction temperature, T<sub>j</sub>, is the temperature at the junction of the bond wire and bond pad and directly affects the reliability of the device. The maximum recommended junction temperature for the devices is 125°C.

The equation for T<sub>j</sub> is as follows:  $T_j = \theta_{JA} * Pd\_total + T_A$

T<sub>j</sub> = Junction Temperature

$\theta_{JA}$  = Junction-to-Ambient Thermal Resistance

Pd<sub>total</sub> = Total Device Power Dissipation (example calculation is in section 1 above)

T<sub>A</sub> = Ambient Temperature

In order to calculate junction temperature, the appropriate junction-to-ambient thermal resistance  $\theta_{JA}$  must be used. Assuming a moderate air flow of 200 linear feet per minute and a multi-layer board, the appropriate value is 42.1°C/W per Table 7 below.

Therefore, T<sub>j</sub> for an ambient temperature of 70°C with all outputs switching is:

$70^\circ C + 1.006W * 42.1^\circ C/W = 112.4^\circ C$ . This is below the limit of 125°C.

This calculation is only an example. T<sub>j</sub> will obviously vary depending on the number of loaded outputs, supply voltage, air flow, and the type of board (single layer or multi-layer).

**TABLE 7. THERMAL RESISTANCE  $\theta_{JA}$  FOR 48-PIN LQFP, FORCED CONVECTION**

| <b><math>\theta_{JA}</math> by Velocity (Linear Feet per Minute)</b> |          |            |            |
|--|----------|------------|------------|
|  | <b>0</b> | <b>200</b> | <b>500</b> |
| Single-Layer PCB, JEDEC Standard Test Boards                         | 67.8°C/W | 55.9°C/W   | 50.1°C/W   |
| Multi-Layer PCB, JEDEC Standard Test Boards                          | 47.9°C/W | 42.1°C/W   | 39.4°C/W   |

**NOTE:** Most modern PCB designs use multi-layered boards. The data in the second row pertains to most designs.

### 3. Calculations and Equations.

The purpose of this section is to derive the power dissipated into the load.

LVPECL output driver circuit and termination are shown in *Figure 6*.

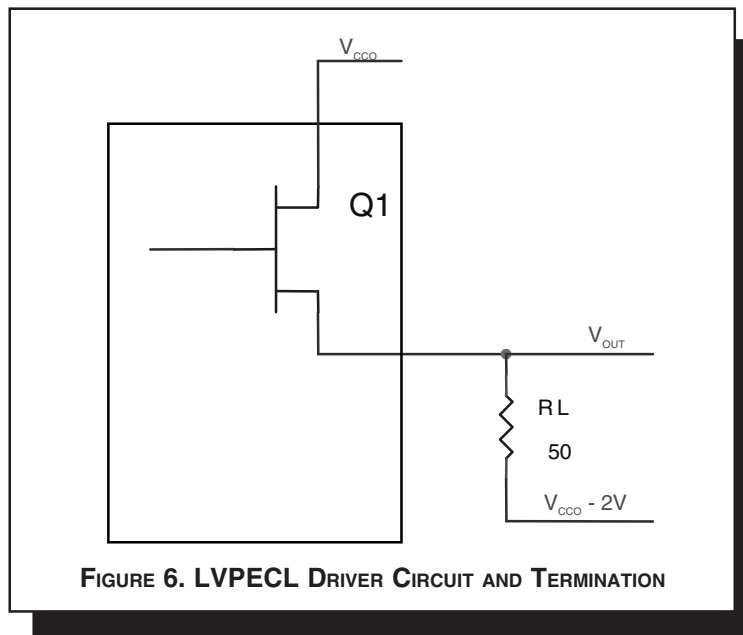

**FIGURE 6. LVPECL DRIVER CIRCUIT AND TERMINATION**

To calculate worst case power dissipation into the load, use the following equations which assume a 50Ω load, and a termination voltage of  $V_{CCO} - 2V$ .

- For logic high,  $V_{OUT} = V_{OH\_MAX} = V_{CCO\_MAX} - 0.9V$

$$(V_{CCO\_MAX} - V_{OH\_MAX}) = 0.9V$$

- For logic low,  $V_{OUT} = V_{OL\_MAX} = V_{CCO\_MAX} - 1.7V$

$$(V_{CCO\_MAX} - V_{OL\_MAX}) = 1.7V$$

$Pd\_H$  is power dissipation when the output drives high.  
 $Pd\_L$  is the power dissipation when the output drives low.

$$Pd\_H = [(V_{OH\_MAX} - (V_{CC\_MAX} - 2V))/R_L] * (V_{CC\_MAX} - V_{OH\_MAX}) = [(2V - (V_{CC} - V_{OH\_MAX}))/R_L] * (V_{CC} - V_{OH\_MAX}) = [(2V - 0.9V)/50\Omega] * 0.9V = \mathbf{19.8mW}$$

$$Pd\_L = [(V_{OL\_MAX} - (V_{CC\_MAX} - 2V))/R_L] * (V_{CC\_MAX} - V_{OL\_MAX}) = [(2V - (V_{CC} - V_{OL\_MAX}))/R_L] * (V_{CC} - V_{OL\_MAX}) = [(2V - 1.7V)/50\Omega] * 1.7V = \mathbf{10.2mW}$$

Total Power Dissipation per output pair =  $Pd\_H + Pd\_L = \mathbf{30mW}$



## RELIABILITY INFORMATION

TABLE 8.  $\theta_{JA}$  vs. AIR FLOW TABLE FOR 48 LEAD LQFP

| $\theta_{JA}$ by Velocity (Linear Feet per Minute) |          |          |          |
|--|----------|----------|----------|
|  | 0        | 200      | 500      |
| Single-Layer PCB, JEDEC Standard Test Boards       | 67.8°C/W | 55.9°C/W | 50.1°C/W |
| Multi-Layer PCB, JEDEC Standard Test Boards        | 47.9°C/W | 42.1°C/W | 39.4°C/W |

**NOTE:** Most modern PCB designs use multi-layered boards. The data in the second row pertains to most designs.

### TRANSISTOR COUNT

The transistor count for ICS8731-01 is: 2883

PACKAGE OUTLINE - Y SUFFIX FOR 48 LEAD LQFP

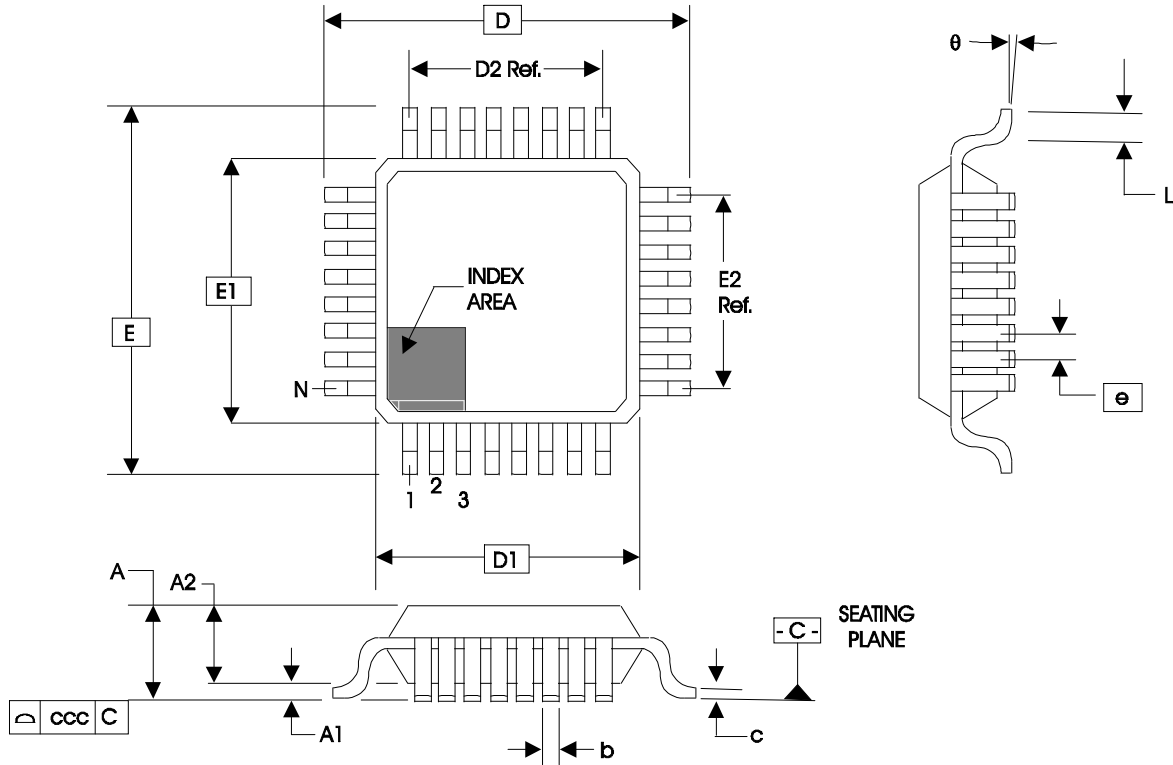

TABLE 9. PACKAGE DIMENSIONS

| JEDEC VARIATION<br>ALL DIMENSIONS IN MILLIMETERS |         |            |         |
|--|---------|------------|---------|
| SYMBOL   | BBC     |            |         |
|  | MINIMUM | NOMINAL    | MAXIMUM |
| N  | 48      |            |         |
| A  |         |            | 1.60    |
| A1   | 0.05    |            | 0.15    |
| A2   | 1.35    | 1.40       | 1.45    |
| b  | 0.17    | 0.22       | 0.27    |
| c  | 0.09    |            | 0.20    |
| D  |         | 9.00 BASIC |         |
| D1   |         | 7.00 BASIC |         |
| D2   |         | 5.50 Ref.  |         |
| E  |         | 9.00 BASIC |         |
| E1   |         | 7.00 BASIC |         |
| E2   |         | 5.50 Ref.  |         |
| e  |         | 0.50 BASIC |         |
| L  | 0.45    | 0.60       | 0.75    |
| theta  | 0°      |            | 7°      |
| ccc  |         |            | 0.08    |

Reference Document: JEDEC Publication 95, MS-026



# ICS8731-01

LOW SKEW, 1-TO-11 DIFFERENTIAL-TO-3.3V LVPECL  
CLOCK MULTIPLIER / ZERO DELAY BUFFER

TABLE 10. ORDERING INFORMATION

| Part/Order Number | Marking      | Package                  | Shipping Packaging | Temperature |
|-------------------|--------------|--------------------------|--------------------|-------------|
| 8731CY-01         | ICS8731CY-01 | 48 Lead LQFP             | tray               | 0°C to 70°C |
| 8731CY-01T        | ICS8731CY-01 | 48 Lead LQFP             | 1000 tape & reel   | 0°C to 70°C |
| 8731CY-01LF       | ICS8731CY01L | 48 Lead "Lead-Free" LQFP | tray               | 0°C to 70°C |
| 8731CY-01LFT      | ICS8731CY01L | 48 Lead "Lead-Free" LQFP | 1000 tape & reel   | 0°C to 70°C |

NOTE: Parts that are ordered with an "LF" suffix to the part number are the Pb-Free configuration and are RoHS compliant.

While the information presented herein has been checked for both accuracy and reliability, Integrated Device Technology, Inc. (IDT) assumes no responsibility for either its use or for infringement of any patents or other rights of third parties, which would result from its use. No other circuits, patents, or licenses are implied. This product is intended for use in normal commercial and industrial applications. Any other applications such as those requiring high reliability, or other extraordinary environmental requirements are not recommended without additional processing by IDT. IDT reserves the right to change any circuitry or specifications without notice. IDT does not authorize or warrant any IDT product for use in life support devices or critical medical instruments.



**ICS8731-01**  
LOW SKEW, 1-TO-11 DIFFERENTIAL-TO-3.3V LVPECL  
CLOCK MULTIPLIER / ZERO DELAY BUFFER

| REVISION HISTORY SHEET |       |          |  |         |
|------------------------|-------|----------|--|---------|
| Rev                    | Table | Page     | Description of Change  | Date    |
| A                      | T10   | 1<br>15  | Features Section - added Lead-Free bullet .<br>Ordering Information Table - added Lead-Free part number, marking and note.       | 6/6/06  |
| B                      | T10   | 15<br>17 | Updated datasheet's header/footer with IDT from ICS.<br>Removed ICS prefix from Part/Order Number column.<br>Added Contact Page. | 7/27/10 |
|                        |       |          |  |         |





**ICS8731-01**  
LOW SKEW, 1-TO-11 DIFFERENTIAL-TO-3.3V LVPECL  
CLOCK MULTIPLIER / ZERO DELAY BUFFER

---

**We've Got Your Timing Solution.**



6024 Silver Creek Valley Road  
San Jose, CA 95138

**Sales**  
800-345-7015 (inside USA)  
+408-284-8200 (outside USA)  
Fax: 408-284-2775

**Tech Support**  
netcom@idt.com