

SCAN182541A

Non-Inverting Line Driver with 25Ω Series Resistor Outputs

General Description

The SCAN182541A is a high performance BiCMOS line driver featuring separate data inputs organized into dual 9-bit bytes with byte-oriented paired output enable control signals. This device is compliant with IEEE 1149.1 Standard Test Access Port and Boundary-Scan architecture with the incorporation of the defined Boundary-Scan test logic and test access port consisting of Test Data Input (TDI), Test Data Out (TDO), Test Mode Select (TMS), and Test Clock (TCK).

Features

- IEEE 1149.1 (JTAG) Compliant
- High performance BiCMOS technology
- 25Ω series resistor outputs eliminate need for external terminating resistors
- Dual output enable signals per byte
- TRI-STATE® outputs for bus-oriented applications
- 25 mil pitch SSOP (Shrink Small Outline Package)
- Includes CLAMP, IDCODE and HIGHZ instructions
- Additional instructions SAMPLE-IN, SAMPLE-OUT and EXTEST-OUT
- Power up TRI-STATE for hot insert
- Member of National's SCAN Products

Ordering Code: See Section 11

Connection Diagram

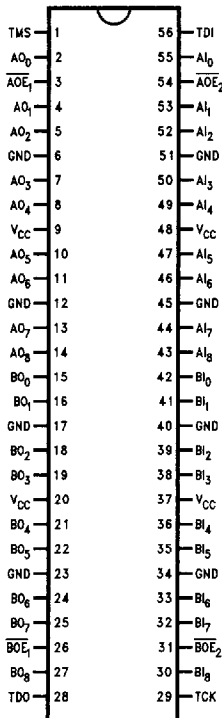

TL/F/11543-1

Pin Names	Description
AI(0-8)	Input Pins, A Side
BI(0-8)	Input Pins, B Side
AOE ₁ , AOE ₂	TRI-STATE Output Enable Input Pins, A Side
BOE ₁ , BOE ₂	TRI-STATE Output Enable Input Pins, B Side
AO(0-8)	Output Pins, A Side
BO(0-8)	Output Pins, B Side

Order Number	Description
SCAN182541ASSC	SSOP in Tubes
SCAN182541ASSCX	SSOP in Tape and Reel
SCAN182541AFMQB	Flatpak Military

Truth Tables

Inputs			AO(0-8)
†AOE ₁	†AOE ₂	AI(0-8)	
L	L	H	H
H	X	X	Z
X	H	X	Z
L	L	L	L

Inputs			BO(0-8)
†BOE ₁	†BOE ₂	BI(0-8)	
L	L	H	H
H	X	X	Z
X	H	X	Z
L	L	L	L

H = HIGH Voltage Level

L = LOW Voltage Level

X = Immaterial

Z = High Impedance

† = Inactive-to-active transition must occur to enable outputs upon power-up.

Block Diagrams

Byte A

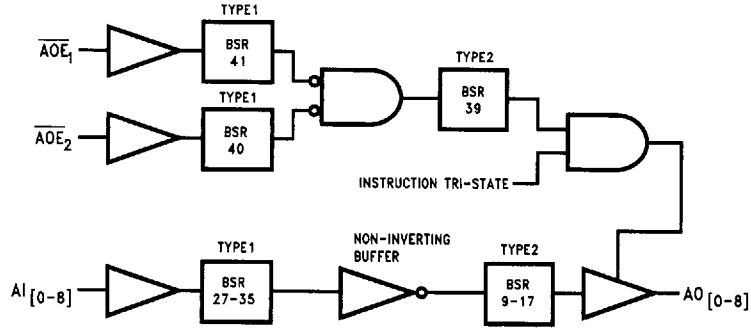

TL/F/11543-2

Tap Controller

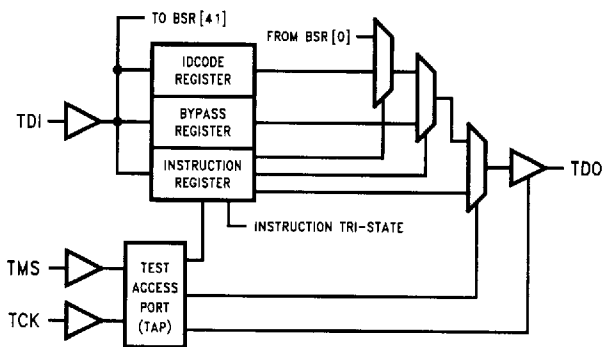

TL/F/11543-3

Byte B

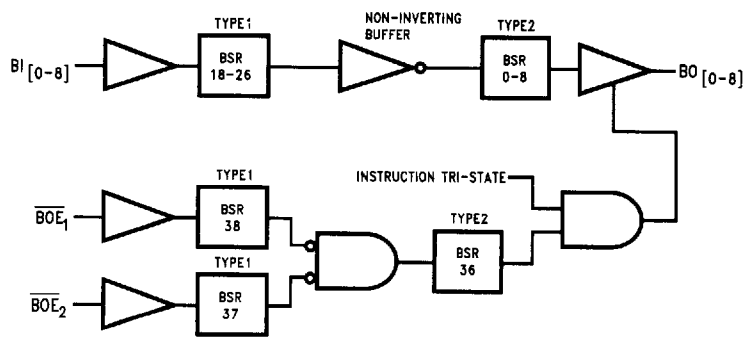

TL/F/11543-4

Note: BSR stands for Boundary Scan Register.

Description of BOUNDARY-SCAN Circuitry

The scan cells used in the BOUNDARY-SCAN register are one of the following two types depending upon their location. Scan cell TYPE1 is intended to solely observe system data, while TYPE2 has the additional ability to control system data. (See IEEE Standard 1149.1 Figure 10-11 for a further description of scan cell TYPE1 and Figure 10-12 for a further description of scan cell TYPE2.)

Scan cell TYPE1 is located on each system input pin while scan cell TYPE2 is located at each system output pin as well as at each of the two internal active-high output enable signals. AOE controls the activity of the A-outputs while BOE controls the activity of the B-outputs. Each will activate their respective outputs by loading a logic high.

The BYPASS register is a single bit shift register stage identical to scan cell TYPE1. It captures a fixed logic low.

Bypass Register Scan Chain Definition Logic 0

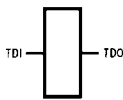

TL/F/11543-17

SCAN182541A Product IDCODE (32-Bit Code per IEEE 1149.1)

Version	Entity	Part Number	Manufacturer ID	Required by 1149.1
0000	1111111	0000001001	00000001111	1

MSB

LSB

The INSTRUCTION register is an 8-bit register which captures the default value of 10000001 (SAMPLE/PRELOAD) during the CAPTURE-IR instruction command. The benefit of capturing SAMPLE/PRELOAD as the default instruction during CAPTURE-IR is that the user is no longer required to shift in the 8-bit instruction for SAMPLE/PRELOAD. The sequence of: CAPTURE-IR → EXIT1-IR → UPDATE-IR will update the SAMPLE/PRELOAD instruction. For more information refer to the section on instruction definitions.

Instruction Register Scan Chain Definition

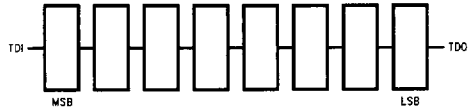

TL/F/11543-26

MSB → LSB

Instruction Code	Instruction
00000000	EXTEST
10000001	SAMPLE/PRELOAD
10000010	CLAMP
00000011	HIGH-Z
01000001	SAMPLE-IN
01000010	SAMPLE-OUT
00100010	EXTEST-OUT
10101010	IDCODE
11111111	BYPASS
All Others	BYPASS

Scan Cell TYPE1

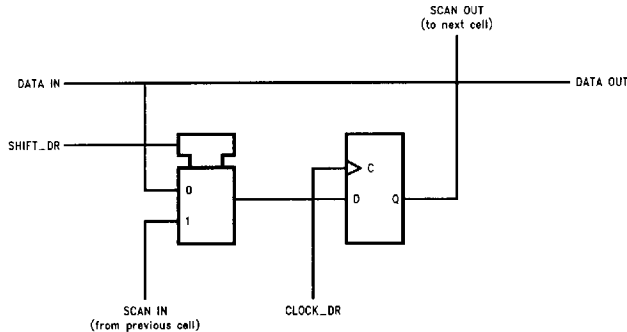

TL/F/11543-30

Scan Cell TYPE2

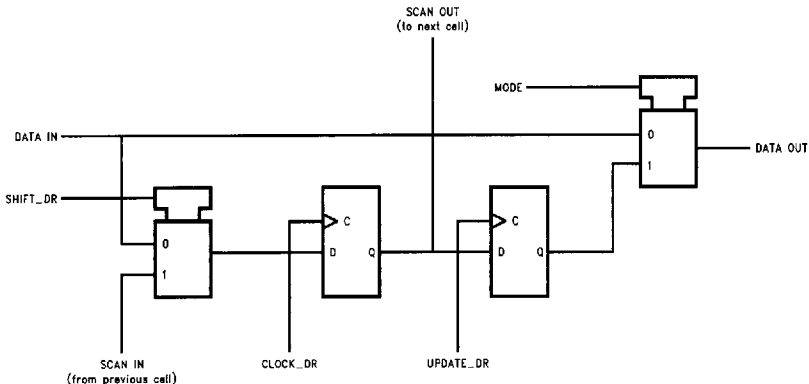

TL/F/11543-31

Description of BOUNDARY-SCAN Circuitry (Continued)

BOUNDARY-SCAN Register Scan Chain Definition (42 Bits In Length)

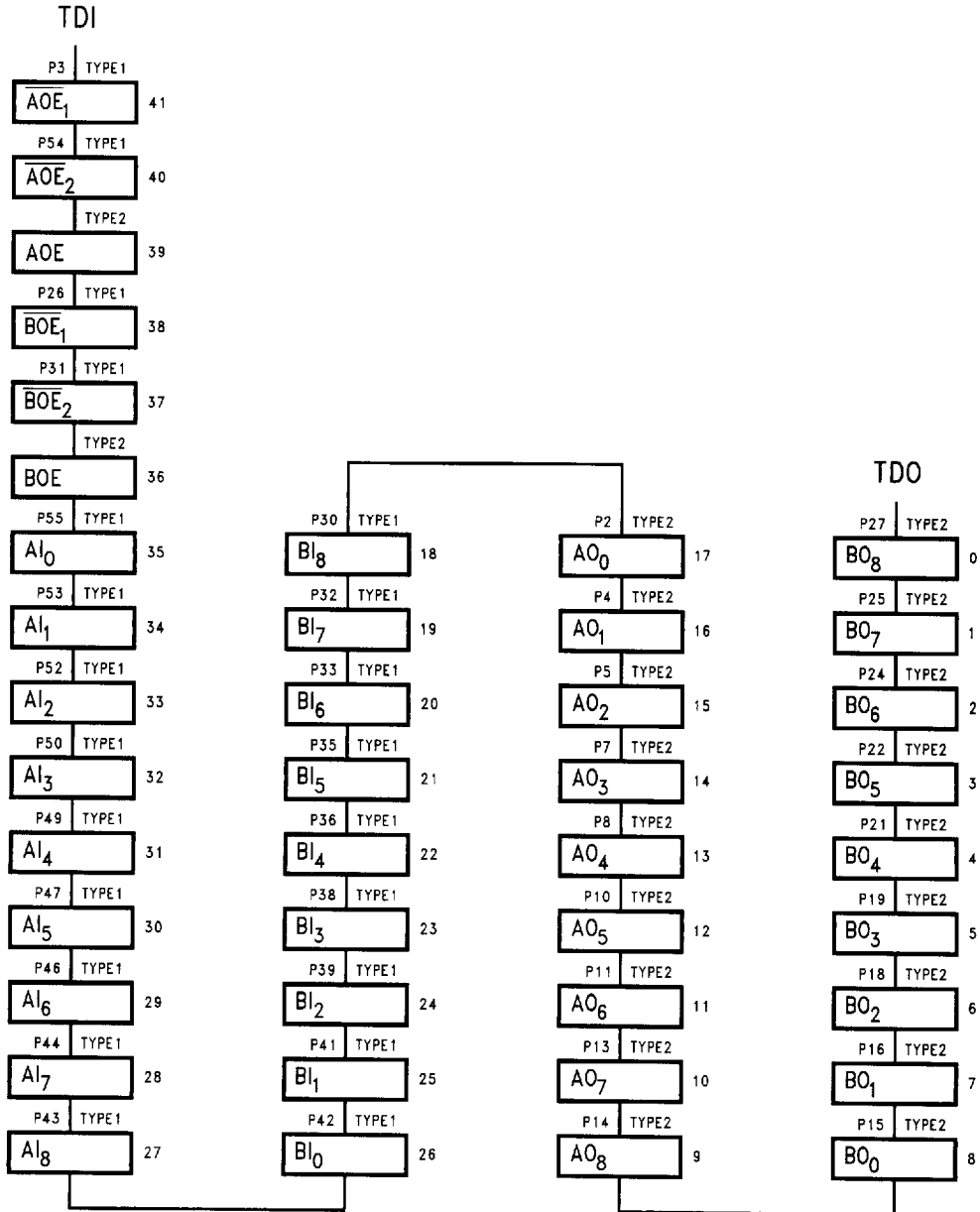

TL/F/11543-27

Description of BOUNDARY-SCAN Circuitry (Continued)

**Input BOUNDARY-SCAN Register
Scan Chain Definition (22 Bits in Length)
When SAMPLE-IN is Active**

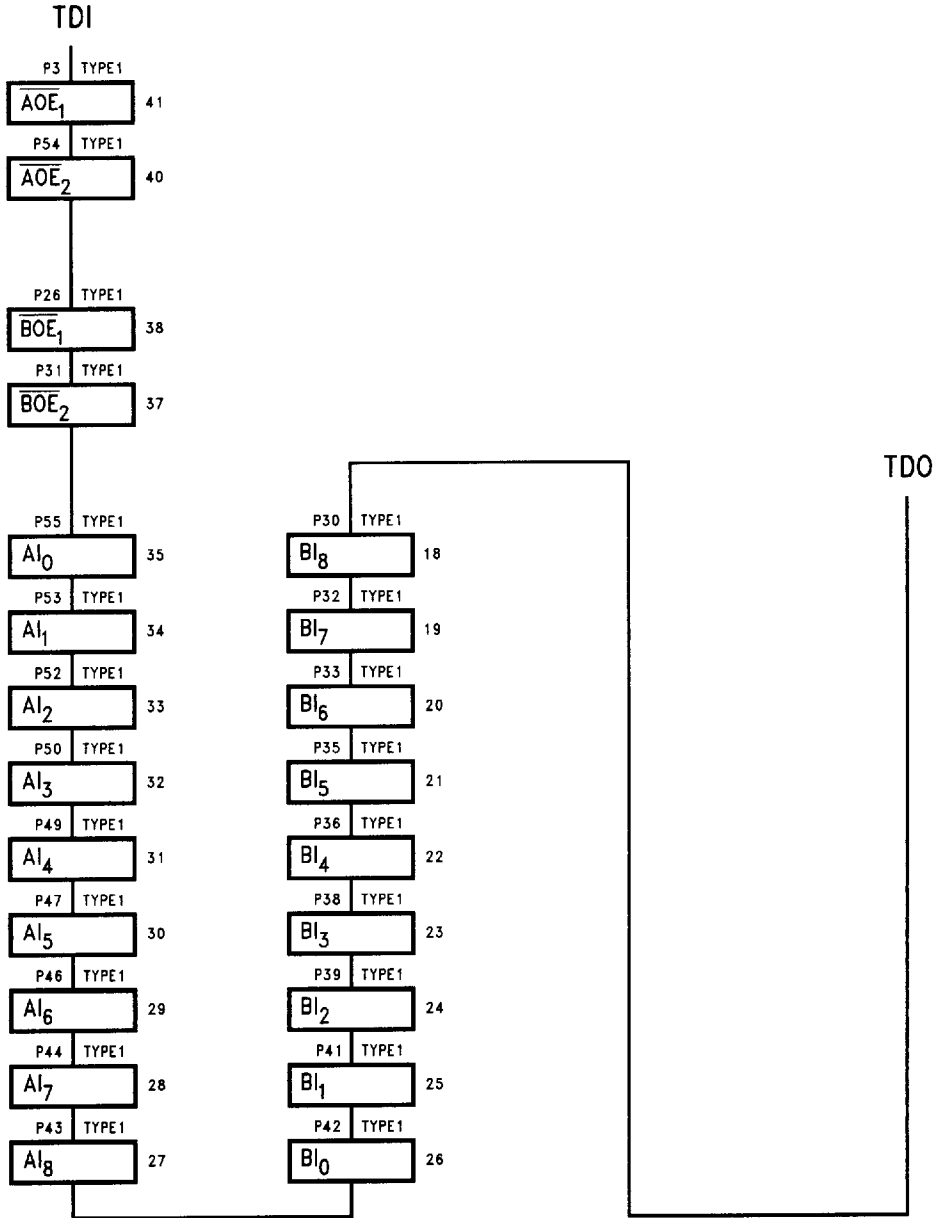

TL/F/11543-28

Description of BOUNDARY-SCAN Circuitry (Continued)

Output BOUNDARY-SCAN Register
Scan Chain Definition (20 Bits in Length)
When SAMPLE-OUT and EXTEXT Out are Active

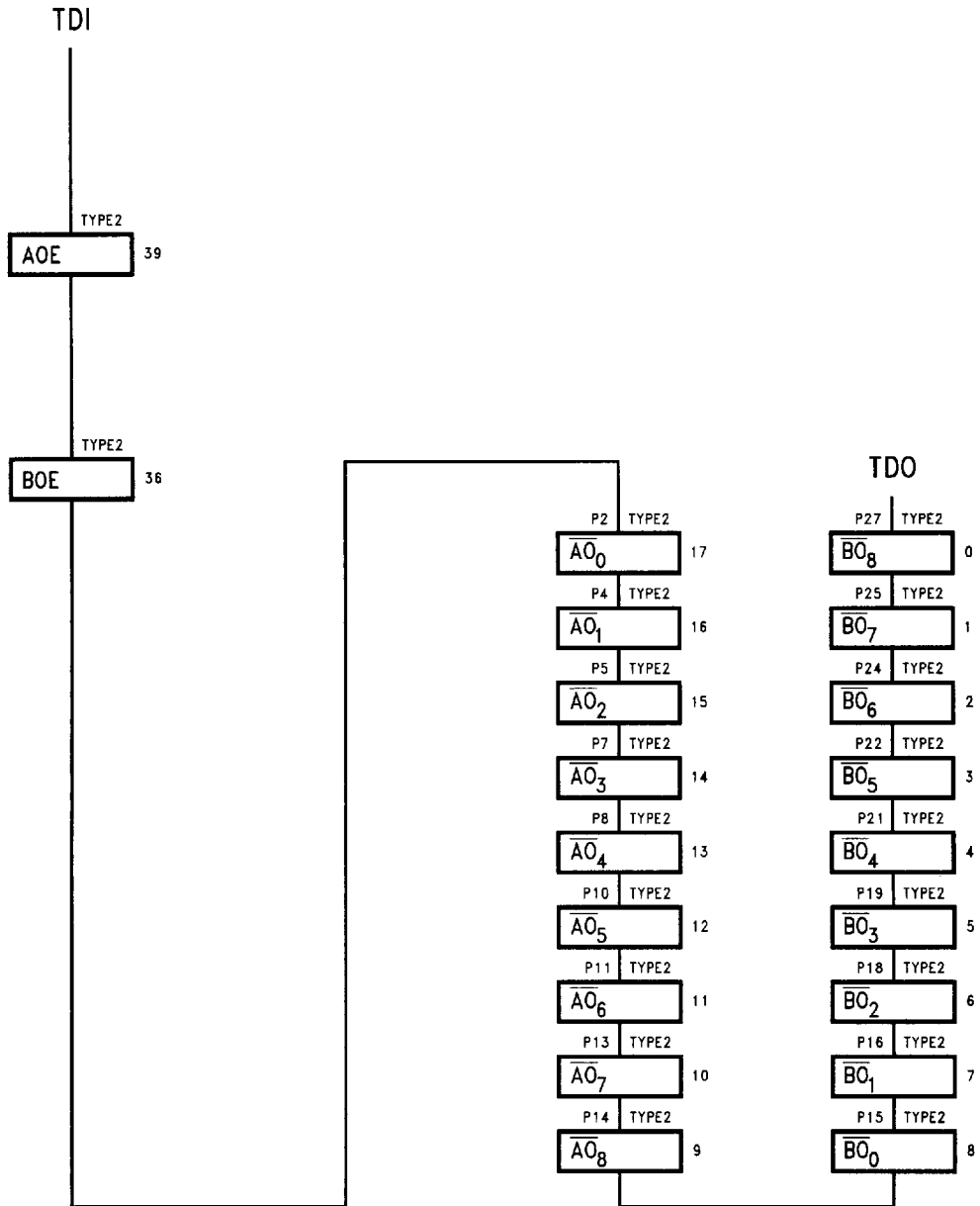

TL/F/11543-29

Description of BOUNDARY-SCAN Circuitry (Continued)

BOUNDARY-SCAN Register Definition Index

Bit No.	Pin Name	Pin No.	Pin Type	Scan Cell Type	
41	\overline{AOE}_1	3	Input	TYPE1	Control Signals
40	\overline{AOE}_2	54	Input	TYPE1	
39	AOE		Internal	TYPE2	
38	\overline{BOE}_1	26	Input	TYPE1	
37	\overline{BOE}_2	31	Input	TYPE1	
36	BOE		Internal	TYPE2	
35	Al ₀	55	Input	TYPE1	A-in
34	Al ₁	53	Input	TYPE1	
33	Al ₂	52	Input	TYPE1	
32	Al ₃	50	Input	TYPE1	
31	Al ₄	49	Input	TYPE1	
30	Al ₅	47	Input	TYPE1	
29	Al ₆	46	Input	TYPE1	
28	Al ₇	44	Input	TYPE1	
27	Al ₈	43	Input	TYPE1	
26	Bl ₀	42	Input	TYPE1	B-in
25	Bl ₁	41	Input	TYPE1	
24	Bl ₂	39	Input	TYPE1	
23	Bl ₃	38	Input	TYPE1	
22	Bl ₄	36	Input	TYPE1	
21	Bl ₅	35	Input	TYPE1	
20	Bl ₆	33	Input	TYPE1	
19	Bl ₇	32	Input	TYPE1	
18	Bl ₈	30	Input	TYPE1	
17	AO ₀	2	Output	TYPE2	A-out
16	AO ₁	4	Output	TYPE2	
15	AO ₂	5	Output	TYPE2	
14	AO ₃	7	Output	TYPE2	
13	AO ₄	8	Output	TYPE2	
12	AO ₅	10	Output	TYPE2	
11	AO ₆	11	Output	TYPE2	
10	AO ₇	13	Output	TYPE2	
9	AO ₈	14	Output	TYPE2	
8	BO ₀	15	Output	TYPE2	B-out
7	BO ₁	16	Output	TYPE2	
6	BO ₂	18	Output	TYPE2	
5	BO ₃	19	Output	TYPE2	
4	BO ₄	21	Output	TYPE2	
3	BO ₅	22	Output	TYPE2	
2	BO ₆	24	Output	TYPE2	
1	BO ₇	25	Output	TYPE2	
0	BO ₈	27	Output	TYPE2	

Absolute Maximum Ratings (Note 1)

If Military/Aerospace specified devices are required, please contact the National Semiconductor Sales Office/Distributors for availability and specifications.

Storage Temperature	-65°C to +150°C
Ambient Temperature under Bias	-55°C to +125°C
Junction Temperature under Bias	
Ceramic	-55°C to +175°C
Plastic	-55°C to +150°C
V _{CC} Pin Potential to Ground Pin	-0.5V to +7.0V
Input Voltage (Note 2)	-0.5V to +7.0V
Input Current (Note 2)	-30 mA to +5.0 mA
Voltage Applied to Any Output in the Disabled or Power-Off State	-0.5V to +5.5V
in the HIGH State	-0.5V to V _{CC}
Current Applied to Output in LOW State (Max)	Twice the Rated I _{OL} (mA)
DC Latchup Source Current	
Commercial	-500 mA
Military	-300 mA

Over Voltage Latchup (I/O) 10V
 EDS (HBM) Min 2000V

Note 1: Absolute Maximum Ratings are values beyond which the device may be damaged or have its useful life impaired. Functional operation under these conditions is not implied.

Note 2: Either voltage limit or current limit is sufficient to protect inputs.

Recommended Operating Conditions

Free Air Ambient Temperature	
Military	-55°C to +125°C
Commercial	-40°C to +85°C
Supply Voltage	
Military	+4.5V to +5.5V
Commercial	+4.5V to +5.5V
Minimum Input Edge Rate	(ΔV/Δt)
Data Input	50 mV/ns
Enable Input	20 mV/ns

DC Electrical Characteristics

Symbol	Parameter	V _{CC}	Min	Typ	Max	Units	Conditions
V _{IH}	Input HIGH Voltage		2.0			V	Recognized HIGH Signal
V _{IL}	Input LOW Voltage				0.8	V	Recognized LOW Signal
V _{CD}	Input Clamp Diode Voltage	Min			-1.2	V	I _{IN} = -18 mA
V _{OH}	Output HIGH Voltage	Min	2.5			V	I _{OH} = -3 mA
		Mil	Min	2.0		V	I _{OH} = -24 mA
		Comm	Min	2.0		V	I _{OH} = -32 mA
V _{OL}	Output LOW Voltage	Mil	Min		0.8	V	I _{OL} = 12 mA
		Comm	Min		0.8	V	I _{OL} = 15 mA
I _{IH}	Input HIGH Current	All Others	Max		5	μA	V _{IN} = 2.7V (Note 1)
			Max		5	μA	V _{IN} = V _{CC}
			TMS, TDI	Max		5	μA
I _{BVI}	Input HIGH Current Breakdown Test	Max		7		μA	V _{IN} = 7.0V
I _{BVIT}	Input HIGH Current Breakdown Test (I/O)	Max		100		μA	V _{IN} = 5.5V
I _{IL}	Input LOW Current	All Others	Max		-5	μA	V _{IN} = 0.5V (Note 1)
			Max		-5	μA	V _{IN} = 0.0V
		TMS, TDI	Max		-385	μA	V _{IN} = 0.0V
V _{ID}	Input Leakage Test	0.0	4.75			v	I _{ID} = 1.9 μA All Other Pins Grounded
I _{IH} + I _{OZH}	Output Leakage Current	Max		50		μA	V _{OUT} = 2.7V
I _{IL} + I _{OZL}	Output Leakage Current	Max		-50		μA	V _{OUT} = 0.5V
I _{OZH}	Output Leakage Current	Max		50		μA	V _{OUT} = 2.7V
I _{OZL}	Output Leakage Current	Max		-50		μA	V _{OUT} = 0.5V
I _{OS}	Output Short-Circuit Current	Max	-100		-275	mA	V _{OUT} = 0.0V

Note 1: Guaranteed not tested.

DC Electrical Characteristics (Continued)

Symbol	Parameter	V _{CC}	Min	Typ	Max	Units	Conditions	
I _{CEX}	Output HIGH Leakage Current	Max			50	μA	V _{OUT} = V _{CC}	
I _{ZZ}	Bus Drainage Test	0.0			100	μA	V _{OUT} = 5.5V All Others Grounded	
I _{CCH}	Power Supply Current	Max			250	μA	V _{OUT} = V _{CC} ; TDI, TMS = V _{CC}	
		Max			1.0	mA	V _{OUT} = V _{CC} ; TDI, TMS = GND	
I _{CCL}	Power Supply Current	Max			65	mA	V _{OUT} = LOW; TDI, TMS = V _{CC}	
		Max			65.8	mA	V _{OUT} = LOW; TDI, TMS = GND	
I _{CCZ}	Power Supply Current	Max			250	μA	TDI, TMS = V _{CC}	
		Max			1.0	mA	TDI, TMS = GND	
I _{CC1}	Additional I _{CC} /Input		All Other Inputs	Max		2.9	mA	V _{IN} = V _{CC} - 2.1V
			TDI, TMS Inputs	Max		3	mA	V _{IN} = V _{CC} - 2.1V
I _{CCD}	Dynamic I _{CC}	No Load	Max		0.2	mA/ MHz	Outputs Open One Bit Toggling, 50% Duty Cycle	

Note 1: Guaranteed not tested.

AC Electrical Characteristics Normal Operation: See Section 4

Symbol	Parameter	V _{CC} * (V)	Military			Commercial			Units	Fig. No.
			T _A = -55°C to +125°C C _L = 50 pF			T _A = -40°C to +85°C C _L = 50 pF				
			Min	Typ	Max	Min	Typ	Max		
t _{PLH} t _{PHL}	Propagation Delay Data to Q	5.0			1.0	3.4	5.2	ns	4-1	
t _{PLZ} t _{PHZ}	Disable Time	5.0			2.0	5.2	8.7	ns	4-3, 4	
t _{PZL} t _{PZH}	Enable Time	5.0			2.4	6.1	9.6	ns	4-3, 4	

*Voltage Range 5.0V ±0.5V

AC Electrical Characteristics

Scan Test Operation: See Section 4

Symbol	Parameter	V _{CC} * (V)	Military			Commercial			Units	Fig. No.
			T _A = -55°C to +125°C C _L = 50 pF			T _A = -40°C to +85°C C _L = 50 pF				
			Min	Typ	Max	Min	Typ	Max		
t _{PLH} t _{PHL}	Propagation Delay TCK to TDO	5.0				3.2 4.5	6.0 7.6	9.4 11.3	ns	4-8
t _{PLZ} t _{PHZ}	Disable Time TCK to TDO	5.0				2.5 3.7	5.8 7.4	9.9 11.8	ns	4-9, 10
t _{PZL} t _{PZH}	Enable Time TCK to TDO	5.0				4.9 3.1	8.6 6.7	12.9 10.7	ns	4-9, 10
t _{PLH} t _{PHL}	Propagation Delay TCK to Data Out during Update-DR State	5.0				3.7 4.9	6.7 8.3	10.3 12.4	ns	4-8
t _{PLH} t _{PHL}	Propagation Delay TCK to Data Out during Update-IR State	5.0				4.2 5.3	7.9 9.2	12.2 13.8	ns	4-8
t _{PLH} t _{PHL}	Propagation Delay TCK to Data Out during Test Logic Reset State	5.0				5.0 6.2	9.4 10.9	14.6 16.4	ns	4-8
t _{PLZ} t _{PHZ}	Disable Time TCK to Data Out during Update-DR State	5.0				3.7 4.3	7.9 8.7	13.0 13.7	ns	4-9, 10
t _{PLZ} t _{PHZ}	Disable Time TCK to Data Out during Update-IR State	5.0				3.7 4.3	8.5 9.4	14.2 14.8	ns	4-9, 10
t _{PLZ} t _{PHZ}	Disable Time TCK to Data Out during Test Logic Reset State	5.0				4.7 5.5	10.1 10.9	16.6 17.3	ns	4-9, 10
t _{PZL} t _{PZH}	Enable Time TCK to Data Out during Update-DR State	5.0				5.5 4.0	9.8 7.9	14.7 12.5	ns	4-9, 10
t _{PZL} t _{PZH}	Enable Time TCK to Data Out during Update-IR State	5.0				5.8 4.3	10.9 9.0	16.5 14.4	ns	4-9, 10
t _{PZL} t _{PZH}	Enable Time TCK to Data Out during Test Logic Reset State	5.0				6.6 4.9	12.5 10.5	19.1 16.9	ns	4-9, 10

*Voltage Range 5.0V ±0.5V

AC Operating Requirements

Scan Test Operation: See Section 4

Symbol	Parameter	V _{CC} * (V)	Military	Commercial	Units	Fig. No.
			T _A = -55°C to +125°C C _L = 50 pF	T _A = -40°C to +85°C C _L = 50 pF		
			Guaranteed Minimum			
t _S	Setup Time Data to TCK (Note 2)	5.0		2.2	ns	4-11
t _H	Hold Time Data to TCK (Note 2)	5.0		1.8	ns	4-11
t _S	Setup Time, H or L AOE _n , BOE _n to TCK (Note 1)	5.0		3.7	ns	4-11
t _H	Hold Time, H or L TCK to AOE _n , BOE _n (Note 1)	5.0		1.8	ns	4-11
t _S	Setup Time, H or L Internal AOE _n , BOE _n , to TCK (Note 3)	5.0		2.7	ns	4-11
t _H	Hold Time, H or L TCK to Internal AOE _n , BOE _n (Note 3)	5.0		1.8	ns	4-11
t _S	Setup Time, H or L TMS to TCK	5.0		7.5	ns	4-11
t _H	Hold Time, H or L TCK to TMS	5.0		1.8	ns	4-11
t _S	Setup Time, H or L TDI to TCK	5.0		5.0	ns	4-11
t _H	Hold Time, H or L TCK to TDI	5.0		2.0	ns	4-11
t _W	Pulse Width TCK	H L	5.0	10.0 10.8	ns	4-12
f _{max}	Maximum TCK Clock Frequency	5.0		50	MHz	
t _{PU}	Wait Time, Power Up to TCK	5.0		100	ns	
t _{DN}	Power Down Delay	0.0		100	ms	

*Voltage Range 5.0V ±0.5V

All Input Timing Delays involving TCK are measured from the rising edge of TCK.

Note 1: Timing pertains to BSR 38 and 41 or BSR 37 and 40.**Note 2:** This delay represents the timing relationship between the data input and TCK at the associated scan cells numbered 0-8, 9-17, 18-26 and 27-35.**Note 3:** This delay represents the timing relationship between AOE/BOE and TCK for scan cells 38 and 39 only.

Capacitance

Symbol	Parameter	Typ	Units	Conditions, T _A = 25°C
C _{IN}	Input Capacitance	5.8	pF	V _{CC} = 0.0V
C _{OUT} (Note 1)	Output Capacitance	13.8	pF	V _{CC} = 5.0V

Note 1: C_{OUT} is measured at frequency f = 1 MHz, per MIL-STD-883B, Method 3012.

Ordering Information and Physical Dimensions

Ordering Information

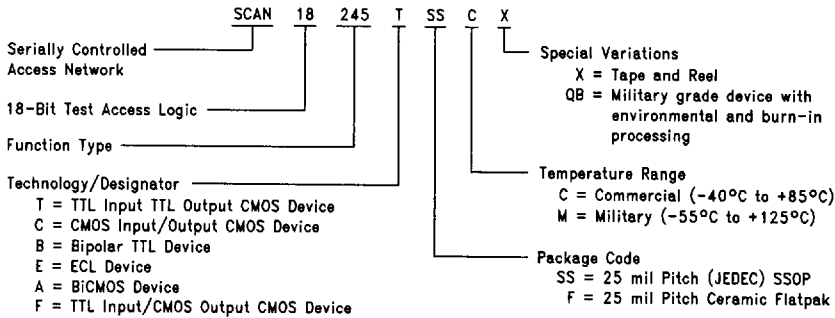

TL/F/11596-9

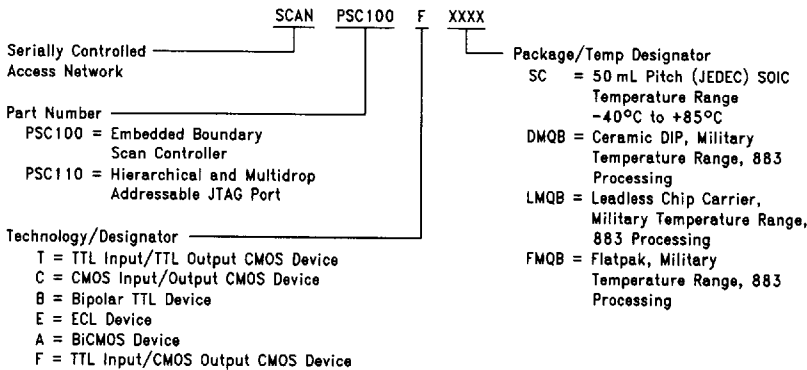

TL/F/11596-10

SSOP Package Thermal Information

THERMAL RESISTANCE FOR SSOP PACKAGES

Package	Paddle Dimensions (mils)	θ_{JA} 0 LFPM (°C/W)	θ_{JA} 225 LFPM (°C/W)	θ_{JA} 500 LFPM (°C/W)	θ_{JA} 900 LFPM (°C/W)	θ_{JC}
20LD SSOP	110 x 144	127.0	99.4	90.1	78.5	N/A
24LD SSOP	98 x 106	117.0	91.4	82.7	73.5	N/A
24LD SSOP	120 x 150	100.8	81.3	72.1	65.7	25.7
48LD SSOP	190 x 190	75.5	58.0	51.5	44.0	21.5
56LD SSOP	190 x 190	67.8	53.0	47.4	42.1	18.5

THERMAL RESISTANCES FOR THE MILITARY FLATPAK PACKAGES

Package	Cavity Dimensions (mils)	θ_{JA} 0 LFPM (°C/W)	θ_{JA} 225 LFPM (°C/W)	θ_{JA} 500 LFPM (°C/W)	θ_{JA} 900 LFPM (°C/W)	θ_{JC}
48LD	250 x 250	74.4	58.1	50.0	43.9	6.6
56LD	250 x 250	59.8	47.9	39.0	35.1	3.4

Dry Pack

Dry Pack is moisture proof packing that is used to store SSOP devices to reduce the susceptibility of the "popcorn effect". Humidity collects inside the package by seeping through the plastic. If moisture is inside the device when the unit goes through a solder machine, the heat quickly changes the moisture to steam, and the pressurized steam pops open the package . . . thus the popcorn effect.

The Dry Pack bag is hermetically sealed and contains a small bag of desiccant which further helps to reduce moisture. All of the SCAN 56-pin SSOP devices will be shipped in Dry Pack bags. Included with the devices will be the following warning label and instructions for re bake:

Dry Pack Warning Label for Surface Mount Packages

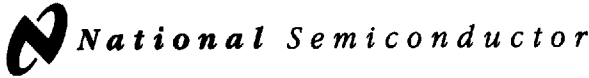



CAUTION

This Bag Contains
MOISTURE SENSITIVE DEVICES



1. Shelf life in sealed bag: 24 months at <math><40^{\circ}\text{C}</math> and <math><90\%</math> Relative Humidity (RH).
2. Upon opening this bag, devices to be subjected to I.R., V.P.R. or equivalent process must be:
 - a. Mounted within 48 hours at factory conditions of <math><30^{\circ}\text{C}/60\%</math> RH, or
 - b. Stored at <math><10\%</math> RH.
3. Devices require baking, before mounting, if:
 - a. Humidity Indicator Card is >20% when read at $23^{\circ}\text{C} \pm 5^{\circ}\text{C}$.
 - b. 2a or 2b are not met.
4. If baking is required, devices may be baked for:
 - a. 19 hours at $40^{\circ}\text{C} + 5^{\circ}\text{C}/ - 0^{\circ}\text{C}$ and <math><5\%</math> RH for low temperature device containers, or
 - b. 8 hours at $125^{\circ}\text{C} \pm 5^{\circ}\text{C}$ for high temperature device containers.

Dry-Pack Seal Date: _____
(IF BLANK, SEE BAR CODE LABEL)

BAG SN 045317 MFR LOT No. C32729

Please follow these instructions carefully to avoid the popcorn effect.

28 Lead Ceramic Leadless Chip Carrier, Type C
NS Package Number E28A

All dimensions are in inches

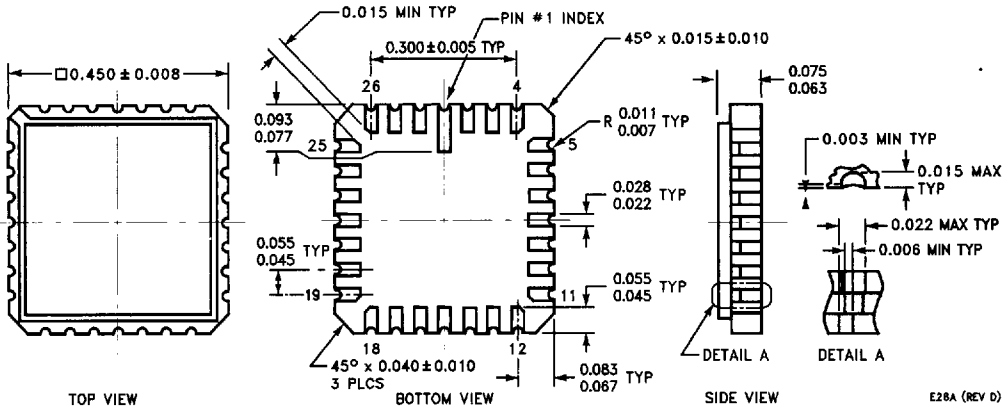

28 Lead Ceramic Dual-in-Line Package
NS Package Number J28A

All dimensions are in inches (millimeters)

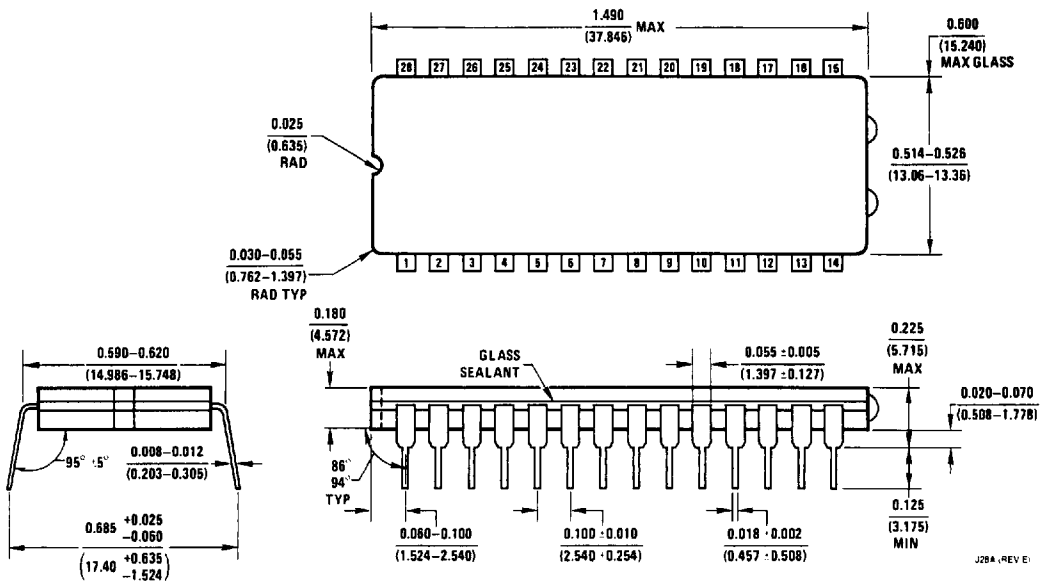

28 Lead (0.300" Wide) Molded Small Outline Package, JEDEC NS Package Number M28B

All dimensions are in inches (millimeters)

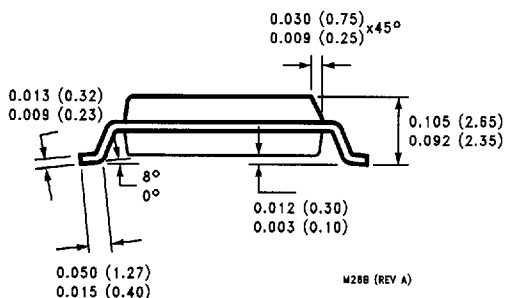
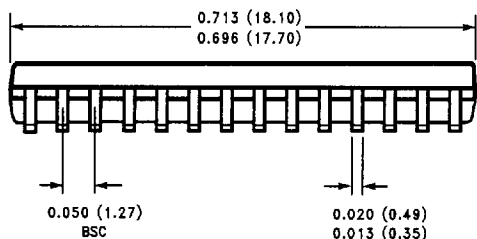
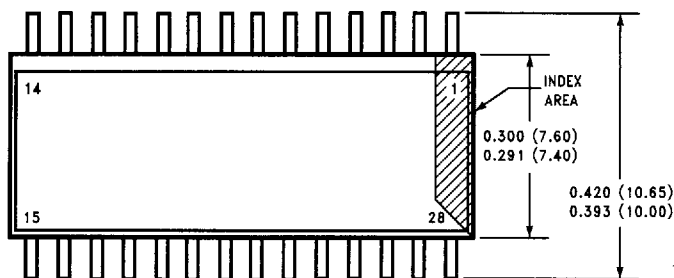

M28B (REV A)

56 Lead (0.300" Wide) Molded Shrink Small Outline Package, JEDEC NS Package Number MS56A

All dimensions are in inches [millimeters]

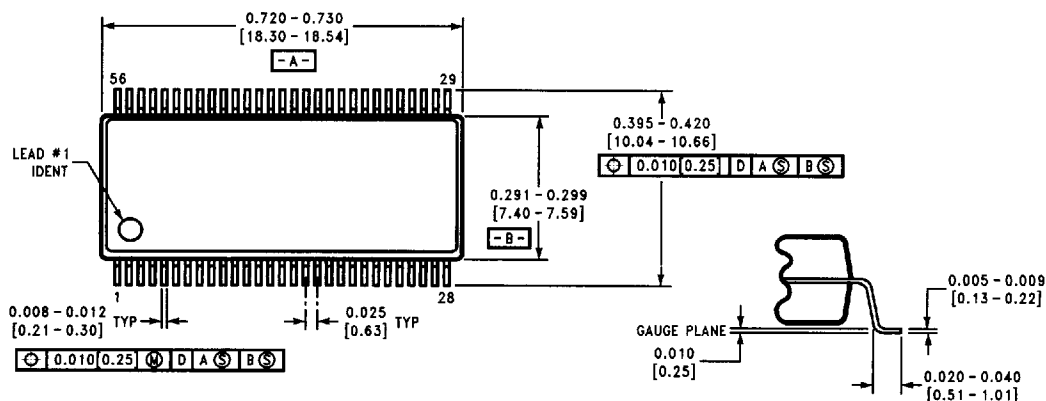

DETAIL E TYP

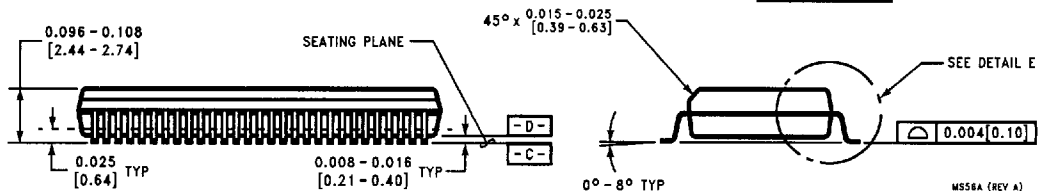

MS56A (REV A)

**28 Lead Cerpack
NS Package Number WA28D**

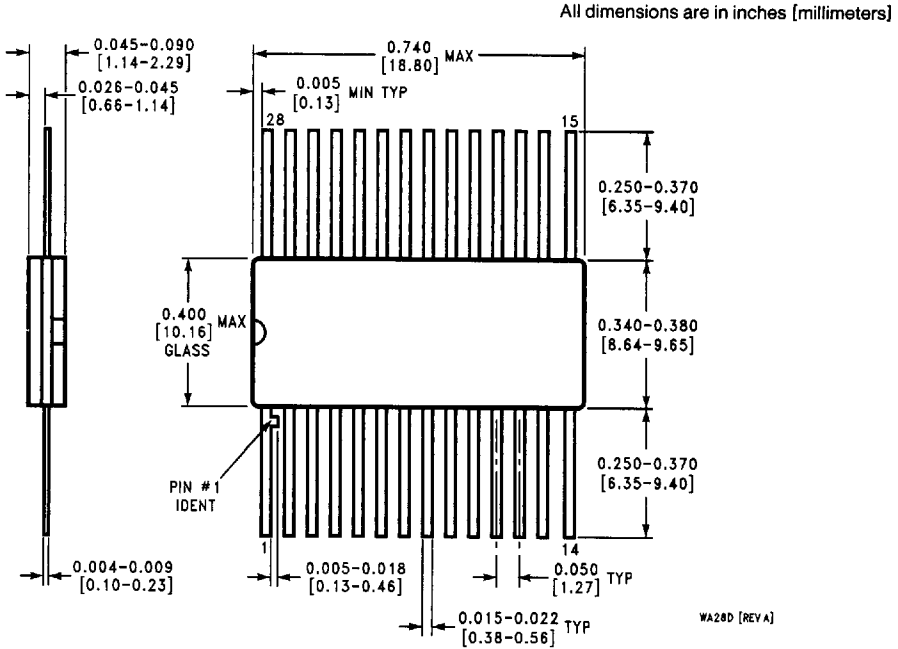

**56 Lead Cerpack
NS Package Number WA56A**

