

S-34

0016

002640

T-2640

G-1

Dual 50-Bit Static Shift Registers

FEATURES

- TTL/DTL Compatible Clock Input
- TTL/DTL Compatible Data—
No external interfacing components required on data inputs or outputs.
- DC-1MHz Operation
- Full Static Operation—
Data is stored independently of the clock logic level.
- Two Temperature Ranges—
SL-5 & SL-7: 0°C to +70°C
SL-6: -55°C to +125°C
- Zener Protected Inputs
- Glass Passivation Protection

DESCRIPTION

The SL-5-2050, SL-6-2050 and SL-7-2050 are dual 50-bit static shift registers with clock and data inputs and outputs that interface directly with TTL/DTL logic arrays without the use of any special interface components. These devices contain two independent common clock 50-bit DC to 1MHz shift registers, constructed on a single monolithic chip utilizing MINS P-Channel enhancement mode transistors. Each shift register bit is implemented with a cross coupled flip-flop, so that data is stored indefinitely regardless of the logic level of the clock. A single phase clock input is provided for both registers. Data on the input is sampled while the clock is at a "0" level and the register shifts on a "0" to "1" transition.

*Available only in Europe (14 Lead Plastic DIP)

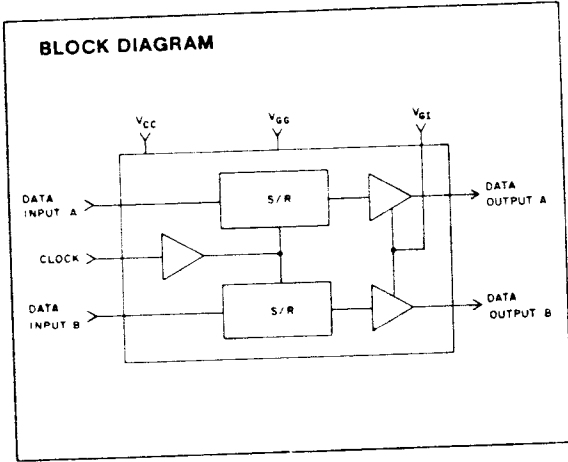

PIN CONFIGURATIONS

14 LEAD DUAL IN-LINE

SL-5-2050, SL-6-2050

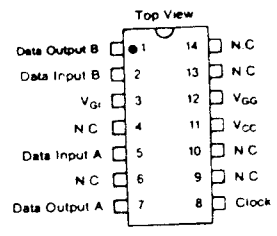

SL-7-2050*

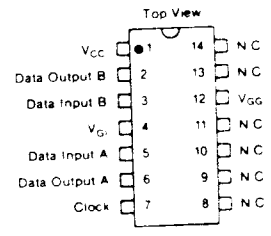

8 LEAD DUAL IN-LINE

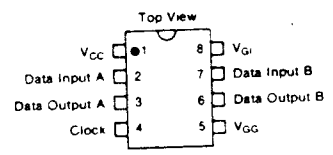

8 LEAD TO-78

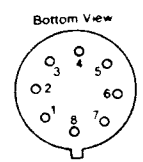

- 1 Data Input A
- 2 Data Output A
- 3 Clock
- 4 VCC
- 5 VGG
- 6 Data Output B
- 7 Data Input B
- 8 VGI

ELECTRICAL CHARACTERISTICS

Maximum Ratings*

V_{GG} and V_{GI} with respect to V_{CC} -20V to +0.3V
 Clock and Data Inputs with respect to V_{CC} -15V to +0.3V
 Storage Temperature -65°C to +150°C
 Operating Temperature: SL-5-2050, SL-7-2050 0°C to +70°C
 SL-6-2050 -55°C to +125°C

*Exceeding these ratings could cause permanent damage. Functional operation of these devices at these conditions is not implied—operating ranges are specified below.

Standard Conditions (unless otherwise noted)

V_{CC} = +5 Volts ± 0.5 Volts (V_{CC} is the substrate voltage)

V_{GG} = -12 Volts ± 1 Volt

V_{GI} = GND

Operating Temperature (T_A) = 0°C to +70°C (SL-5-2050, SL-7-2050)

= -55°C to +125°C (SL-6-2050)

One TTL load (C_L total = 10 pF)

Characteristic	Symbol	Min	Typ**	Max	Units	Conditions
DC CHARACTERISTICS						
Clock Input						
Logic 1 Level	V_{OH}	$V_{CC}-1.5$	—	—	Volts	$V_{in} = V_{CC} - 10V$
Logic 0 Level	V_{OL}	—	—	+0.8	Volts	
Leakage	I_{L0}	—	—	10	μA	
Data Input						
Logic 1 Level	V_{IH}	$V_{CC}-1.5$	—	—	Volts	$V_{in} = V_{CC} - 10V$
Logic 0 Level	V_{IL}	—	—	+0.8	Volts	
Leakage	I_{LI}	—	—	10	μA	
Data Output						
Logic 1 Level	V_{OH}	$V_{CC}-1.0$	—	—	Volts	$I_{OH} = 100 \mu A$ $I_{OL} = 1.6 mA$
Logic 0 Level	V_{OL}	—	—	+0.4	Volts	
Power	—	—	200	275	mW	SL-5-2050, SL-7-2050 SL-6-2050
	—	—	200	300	mW	
AC CHARACTERISTICS						
Clock Input						
Frequency	f	DC	—	1.0	MHz	} $t_r + t_{pdw} + t_f$ } $t_{ed} \geq 1 \mu sec$ 1MHz, $T_A = +25^\circ C$
Pulse Width	t_{pdw}	450	250	—	ns	
Pulse Delay	t_{ed}	450	—	—	ns	
Rise and Fall Times	t_r, t_f	—	—	1000	ns	
Capacitance	C_e	—	20	—	pF	
Data Input						
Set Up Time	t_{DS}	350	250	—	ns	1MHz, $T_A = +25^\circ C$
Hold Time	t_{DH}	10	0	—	ns	
Capacitance	C_i	—	5	—	pF	
Data Output						
Propagation Delay	t_{pd}	—	300	400	ns	SL-5-2050, SL-7-2050 SL-6-2050
	t_{pd}	—	300	500	ns	

**Typical values are at +25°C and nominal voltages.

TIMING DIAGRAM

