

FEATURES

- 4.0 % EVM @ $P_{OUT} = +16$ dBm with IEEE 802.11g 64 QAM OFDM at 54 Mbps
- -40 dBr 1st Sidelobe/-58 dBr 2nd Sidelobe ACPR at +18 dBm with IEEE 802.11b at 1, 2, 5.5, 11 Mbps, Root Cosine Baseband Filtering
- SP3T RF Switch to Enable Bluetooth Path
- Single +3.6 V Supply
- Transmit Path Linear Power Gain of 27 dB
- Temperature-Compensated Linear Power Detector with Positive Slope
- Receive Path In-Band Gain of 14 dB
- Receive Path Noise Figure of 2.3 dB
- 3 mm x 3 mm x 0.55 mm ULPCC Package

APPLICATIONS

- 802.11b/g WLAN in Cell Phone Designs
- 802.11n in WLAN MIMO Systems
- 2.4 GHz Cordless Phone Handsets/Basestations

PRODUCT DESCRIPTION

The ANADIGICS AWL6254 is a high performance InGaP HBT power amplifier, low-noise amplifier, and RF switch integrated on a single IC. It is particularly applicable to cell phone designs that integrate 802.11b/g WLAN in the 2.4 - 2.5 GHz band. Matched to 50 Ω on all RF ports, the part requires no additional RF matching components off-chip.

The antenna port is switched between WLAN transmit, WLAN receive, and Bluetooth paths with a low-loss single-pole triple-throw RF switch. The transmit path PA exhibits unparalleled linearity for both IEEE 802.11b/g/n WLAN systems under the toughest signal configurations within these standards. The WLAN receive path from the antenna port to receiver output port provides a low noise, high-gain path to the system receiver chain.

The positive slope power detector is temperature-compensated on the chip, enabling a single-ended output voltage with excellent accuracy over a wide range of operating temperatures. The AWL6254 is biased by a single +3.6 V supply and consumes ultra-low current in the OFF mode.

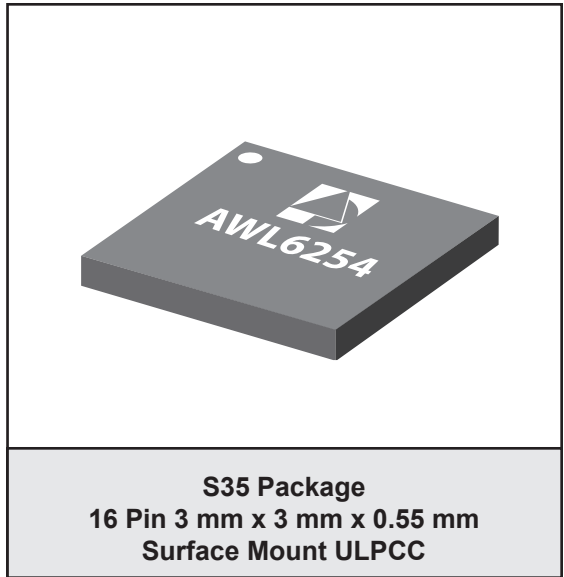

The AWL6254 is manufactured using advanced InGaP HBT technology that offers state-of-the-art reliability, temperature stability and ruggedness. It is provided in a 3 mm x 3 mm x 0.55 mm ULPCC package optimized for a 50 Ω system.

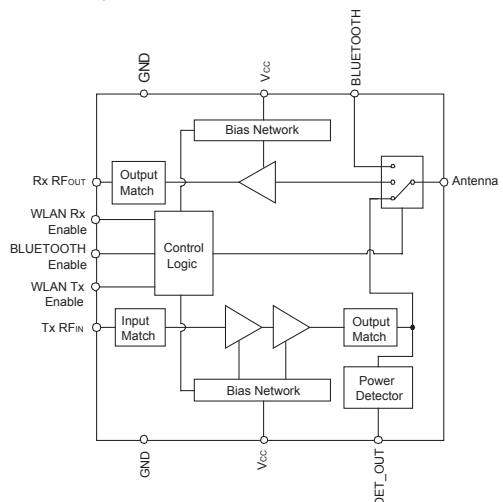

Figure 1: Block Diagram and Pinout

Table 1: Pin Description

PIN	NAME	DESCRIPTION
1	BLUETOOTH	Bluetooth RF Port
2	GND	Ground
3	RX_RF	Receive RF Port
4	GND	Ground
5	LNA_EN	LNA Enable. On/Off control for the Rx path low noise amplifier
6	BT_EN	Bluetooth Enable. On/Off control for the Bluetooth path
7	PA_EN	Power Amplifier Enable. On/Off control for the Tx path power amplifier
8	GND	Ground
9	PA_IN	Power Amplifier Input
10	GND	Ground
11	NC	No Connection
12	V _{CC}	Power Supply. Bias for the transistors in the part
13	DET_OUT	Power Detector Output. DC coupled power detector output. An emitter follower BJT supplies the output for this pin.
14	GND	Ground
15	ANT	Antenna Port. Common connection for the PA, LNA, and Bluetooth paths
16	GND	Ground

ELECTRICAL CHARACTERISTICS

Table 2: Absolute Minimum and Maximum Ratings

PARAMETER	MIN	TYP	MAX	UNIT	COMMENTS
DC Power Supply Voltage (V_{CC})	-	-	+5.0	V	No RF Signal Applied
DC Power Control Voltage (V_{PA_EN})	-	-	+5.0	V	No RF Signal Applied
DC Power Control Voltage (V_{LNA_EN})	-	-	+5.0	V	No RF Signal Applied
DC Power Control Voltage (V_{BT_EN})	-	-	+5.0	V	No RF Signal Applied
DC Current Consumption	-	-	300	mA	
Tx RF Input Level (RF_{IN})	-	-	0	dBm	
Ant RF Input Level (RF_{IN})	-	-	-3	dBm	
Bluetooth RF Input Level (RF_{IN})	-	-	23	dBm	
Storage Case Temperature	-55	-	+150	°C	
Operating Case Temperature	-40	-	+85	°C	
ESD Tolerance	500	1000	-	VDC	All pins, forward and reverse voltage. Human Body Model (HBM)
MSL Rating	-	-	MSL-3		
Reflow Temperature	-	-	250	°C	

Stresses in excess of the absolute ratings may cause permanent damage. Functional operation is not implied under these conditions. Exposure to absolute ratings for extended periods of time may adversely affect reliability.

Table 3: Operating Ranges

PARAMETER	MIN	TYP	MAX	UNIT	COMMENTS
Operating Frequency (f)	2400	-	2500	MHz	
DC Power Supply Voltage (V_{CC})	+3.3	+3.6	+4.2	V	
Control Voltage (V_{PA_EN} , V_{LNA_EN} , V_{BT_EN})	+2.0 0	+3.3 -	+4.2 +0.4	V	PA "ON" PA "SHUTDOWN"
Case Temperature (T_c)	-40	-	+85	°C	
Control Pin Impedance (V_{PA_EN} , V_{LNA_EN} , V_{BT_EN})	-	720	-	k Ω	

The device may be operated safely over these conditions; however, parametric performance is guaranteed only over the conditions defined in the electrical specifications.

Table 4: DC Electrical Specifications - Tx Path Continuous Wave
 (T_C = +25 °C, V_{CC} = +3.6 V, V_{PA_EN} = +3.3 V, V_{LNA_EN} = 0 V, V_{BT_EN} = 0 V)

PARAMETER	MIN	TYP	MAX	UNIT	COMMENTS
P1dB	-	22.5	-	dBm	
Current at P1dB	-	190	-	mA	
Shutdown Current	-	75	-	μA	Shutdown Mode
Quiescent Current	-	27	-	mA	V _{CC} = +3.6 V, V _{PA_EN} = +3.3 V, V _{LNA_EN} = 0 V, V _{BT_EN} = 0 V, RF = off
Input Return Loss, Tx RF _{IN}	-	-10	-	dB	
Output Return Loss, Antenna Port, Switch in Transmit Mode	-	-14	-	dB	Switch in Tx Position
Reverse Isolation (Antenna Port to Tx Input Port)	-	40	-	dB	Switch in Tx Position, signal injected into Antenna port and measured at Tx input port, PA = "ON"
Stability (Spurious)	-	-65	-	dBc	6:1 VSWR, P _{OUT} = +18 dBm, -40 °C

Table 5: Electrical Specifications - Tx Path 802.11g
 (T_C = +25 °C, V_{CC} = +3.6 V, V_{PA_EN} = +3.3 V, V_{LNA_EN} = 0 V, V_{BT_EN} = 0 V, 64 QAM OFDM 54 Mbps)

PARAMETER	MIN	TYP	MAX	UNIT	COMMENTS
Operating Frequency	2400	-	2500	MHz	
Power Gain	-	27	-	dB	
Gain Ripple	-	± 1.5	-	dB	Across any 100 MHz band
Error Vector Magnitude (EVM)	-	4.0	-	%	P _{OUT} = +16 dBm ^{(1), (2)}
	-	-28	-	dB	
Tx Spectrum Mask	Pass	-	-	N/A	P _{OUT} = +16 dBm ⁽²⁾
Current Consumption	-	80	-	mA	P _{OUT} = +16 dBm ⁽²⁾
Harmonics					
2fo	-	-44	-	dBc	P _{OUT} = +18 dBm ⁽²⁾
3fo	-	-55	-	dBc	
Power Detector Voltage	-	0.75	-	V	P _{OUT} = +18 dBm ⁽²⁾
Power Detector Sensitivity	-	65	-	mV/dB	10 dBm < P _{OUT} < +17 dBm ⁽²⁾

Note:

(1) EVM includes system noise floor of 1% (-40 dB).

(2) Power as measured at Antenna port of AWL6254

Table 6: Electrical Specifications - Tx Path 802.11b
 (T_C = +25 °C, V_{CC} = +3.6 V, V_{PA_EN} = +3.3 V, V_{LNA_EN} = 0 V, V_{BT_EN} = 0 V,
 1 Mbps, Root Cosine Baseband Filtering, $\alpha = 0.45$)

PARAMETER	MIN	TYP	MAX	UNIT	COMMENTS
Operating Frequency	2400	-	2500	MHz	
Power Gain	-	27	-	dB	
Gain Ripple	-	± 1.5	-	dB	Across any 100 MHz band
Adjacent Channel Power (ACPR) 1st Sidelobe (± 11 MHz Offset)	-	-40	-	dBr	P _{OUT} = +18 dBm ⁽¹⁾
Adjacent Channel Power (ACPR) 2nd Sidelobe (± 22 MHz Offset)	-	-58	-	dBr	P _{OUT} = +18 dBm ⁽¹⁾
Tx Spectrum Mask	Pass	-	-	N/A	P _{OUT} = +18 dBm ⁽¹⁾
Current Consumption	-	100	-	mA	P _{OUT} = +18 dBm ⁽¹⁾
Harmonics 2fo 3fo	- - -	-37 -53	- -	dBc	P _{OUT} = +18 dBm ⁽¹⁾
Power Detector Voltage	-	0.90	-	V	P _{OUT} = +18 dBm ⁽¹⁾
Power Detector Sensitivity	-	75	-	mV/dB	10 dBm < P _{OUT} < +20 dBm ⁽¹⁾

Note:

(1) Power as measured at Antenna port of AWL6254

Table 7: DC Electrical Specifications - Rx Path Continuous Wave
 (T_C = +25 °C, V_{CC} = +3.6 V, V_{PA_EN} = 0 V, V_{LNA_EN} = +3.3 V, V_{BT_EN} = 0 V)

PARAMETER	MIN	TYP	MAX	UNIT	COMMENTS
Power Gain	-	14	-	dB	
Gain Ripple	-	±0.5	-	dB	Across any 100 MHz Band
Current Consumption	-	11.5	-	mA	P _{OUT} = 0 dBm ⁽¹⁾
P1dB	-	7	-	dBm	
Current at P1dB	-	11.5	-	mA	
Quiescent Current	-	11.5	-	mA	
Noise Figure	-	2.3	-	dB	Includes RF switch and LNA
Return Loss, Rx RF Port	-	-20	-	dB	Switch in Rx position, Antenna port terminated in 50 Ω load
Return Loss, Antenna Port, Switch in Receive Mode	-	-7	-	dB	Switch in Rx position, with 50 Ω Rx port load
Isolation (Antenna Port to Rx Port)	-	35	-	dB	Switch in Tx position, signal injected into Antenna port and measured at Rx port, PA = "ON"
S21 Performance (@ 1.9 GHz)	-	-7	-	dB	

Note:

(1) Power as measured at Antenna port of AWL6254

Table 8: DC Electrical Specifications - Bluetooth Path Continuous Wave
 (T_c = +25 °C, V_{CC} = +3.6 V, V_{PA_EN} = 0 V, V_{LNA_EN} = 0 V, V_{BT_EN} = +3.3 V)

PARAMETER	MIN	TYP	MAX	UNIT	COMMENTS
Insertion Loss	-	1.0	-	dB	2.4 GHz to 2.5 GHz
Quiescent Current	-	-	1	mA	P _{OUT} = 0 dBm ⁽¹⁾
P1dB	-	21	-	dBm	
Return Loss, Bluetooth RF Port	-	-11	-	dB	Switch in Bluetooth position, Antenna port terminated in 50 Ω load
Return Loss, Antenna Port, Switch in Bluetooth Mode	-	-11	-	dB	Switch in Bluetooth position, Bluetooth port terminated in 50 Ω load
Isolation (Antenna Port to Rx Port)	-	22	-	dB	Switch in Bluetooth position, signal injected into Antenna port and measured at Rx port, PA = "ON"

Note:

(1) Power as measured at Antenna port of AWL6254

Table 9: Control Logic Truth Table

FEIC MODE	PA ENABLE	BLUETOOTH ENABLE	LNA ENABLE	PA STATUS	LNA STATUS	SWITCH STATUS
Shutdown	0	0	0	Off	Off	Not Connected
WLAN Rx	0	0	1	Off	On	WLAN Rx
Bluetooth	0	1	0	Off	Off	Bluetooth
WLAN Tx	1	0	0	On	Off	WLAN Tx

Note:

1. Logic State 0 = 0 - 0.4 V; Logic State 1 = 2.0 - 4.2 V

Table 10: Control Voltages and Timing
 (T_c = +25 °C, V_{CC} = +3.6 V, Other Voltages Defined by Logic Below)

PARAMETER	MIN	TYP	MAX	UNIT	COMMENTS
Mode Switch Timing	-	1	-	μs	Tx - Rx - Bluetooth - Shutdown
LNA Enable Pin Control Voltage	+2.0 -	- -	- +0.4	V	LNA = 1 LNA = 0
Bluetooth Enable Pin Control Voltage	+2.0 -	- -	- +0.4	V	Switch = 1 Switch = 0
PA Enable Pin Control Voltage	+2.0 -	- -	- +0.4	V	PA = 1 PA = 0

Note:

1. Logic State 0 = 0 - 0.4 V; Logic State 1 = 2.0 - 4.2 V

PERFORMANCE DATA

Figure 2: Gain and I_{cc} vs. Output Power Across Freq (V_{CC} = +3.6 V, T_A = +25°C) 802.11g 54 Mbps OFDM

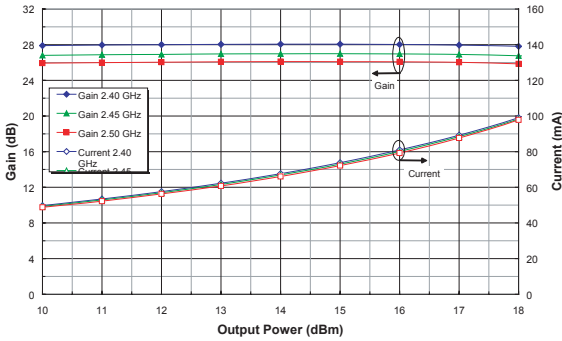

Figure 3: Gain and I_{cc} vs. Output Power Across Temp (Freq = 2.45 GHz, V_{CC} = +3.6 V) 802.11g 54 Mbps OFDM

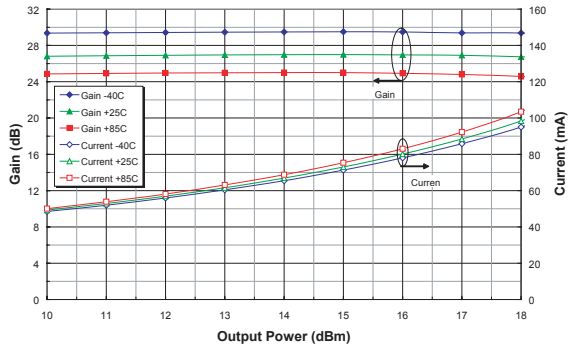

Figure 4: Gain and I_{cc} vs. Output Power Across Power Supply Voltage (Freq = 2.45 GHz, T_A = 25°C) 802.11g 54 Mbps OFDM

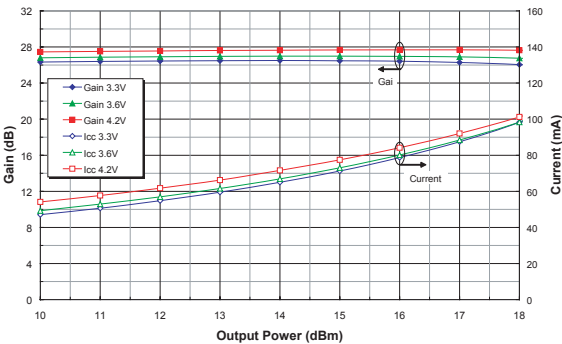

Figure 5: EVM vs. Output Power Across Freq (V_{CC} = +3.6 V, T_A = 25°C) 802.11g 54 Mbps OFDM

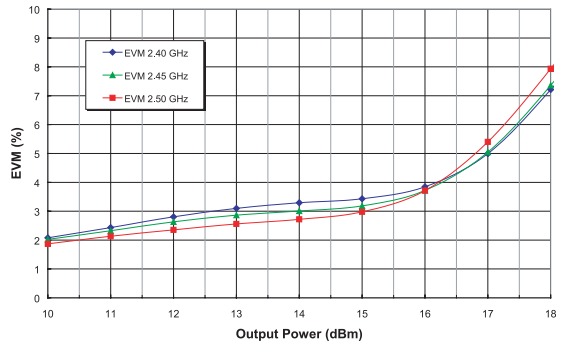

Figure 6: EVM vs. Output Power Across Temp (Freq = 2.45 GHz, V_{CC} = +3.6 V) 802.11g 54 Mbps OFDM

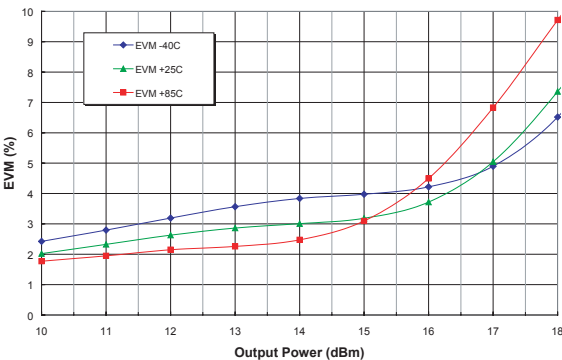
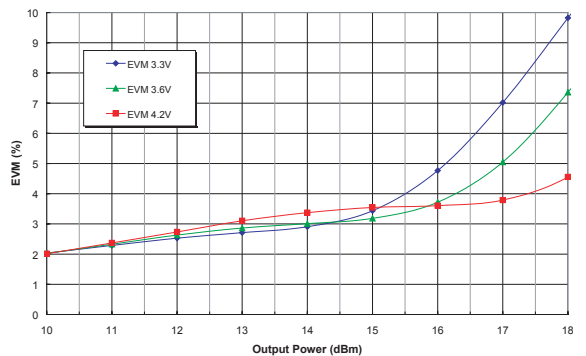
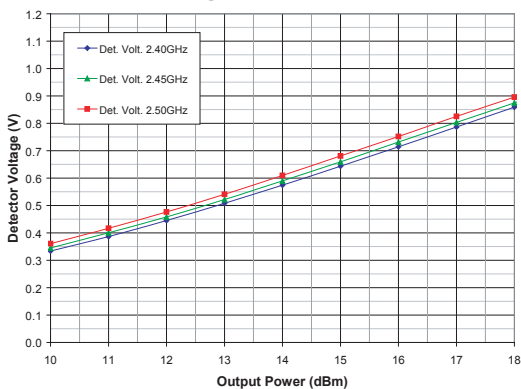

Figure 7: EVM vs. Output Power Across Power Supply Voltage (Freq = 2.45 GHz, T_A = 25°C) 802.11g 54 Mbps OFDM



**Figure 8: Detector Voltage vs. Output Power Across Freq ($T_A = 25^\circ\text{C}$, $V_{CC} = +3.6\text{ V}$)
802.11g 54 Mbps OFDM**



**Figure 9: Detector Voltage vs. Output Power Across Temp (Freq = 2.45 GHz, $V_{CC} = +3.6\text{ V}$)
802.11g 54 Mbps OFDM**

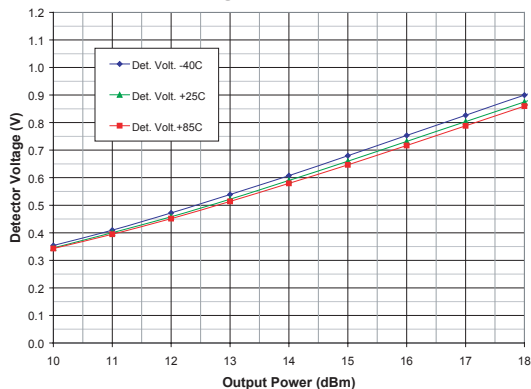

**Figure 10: Gain and I_{CC} vs. Output Power Across Freq ($V_{CC} = +3.6\text{ V}$, $T_A = +25^\circ\text{C}$)
802.11b Root Cosine Filtering ($\alpha = 0.45$), 1 Mbps**

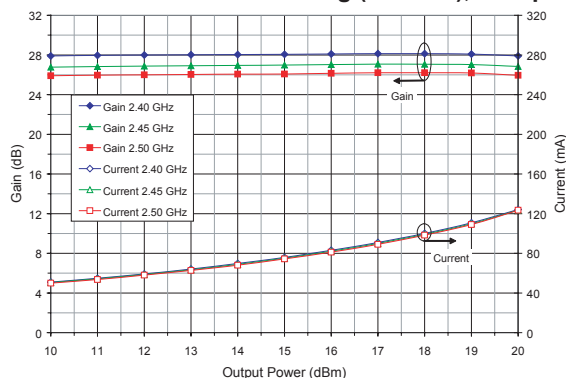

**Figure 11: Gain and I_{CC} vs. Output Power Across Temp (Freq = 2.45 GHz, $V_{CC} = +3.6\text{ V}$)
802.11b Root Cosine Filtering ($\alpha = 0.45$), 1 Mbps**

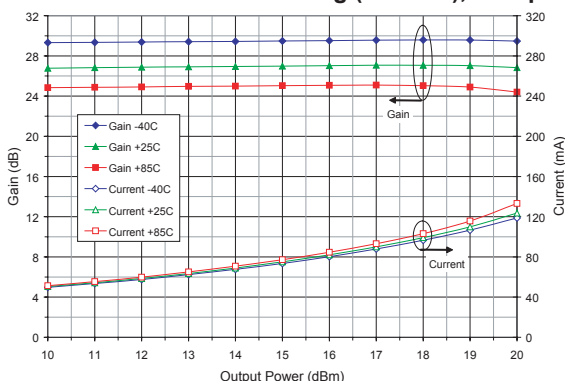

Figure 12: Gain and I_{CC} vs. Output Power Across Power Supply Voltage (Freq = 2.45 GHz, $T_A = 25^\circ\text{C}$)

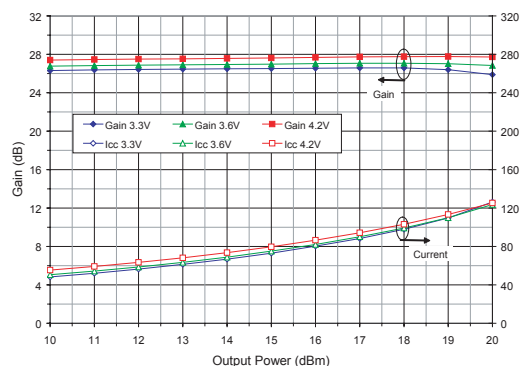

Figure 13: ACPR 1st and 2nd Sidelobes vs. Output Power Across Freq ($V_{CC} = +3.6\text{ V}$, $T_A = +25^\circ\text{C}$)

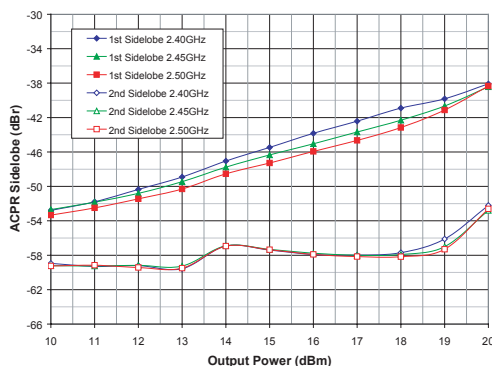

Figure 14: ACPR 1st and 2nd Sidelobes vs. Output Power Across Temp (Freq = 2.45 GHz, V_{CC} = +3.6 V)

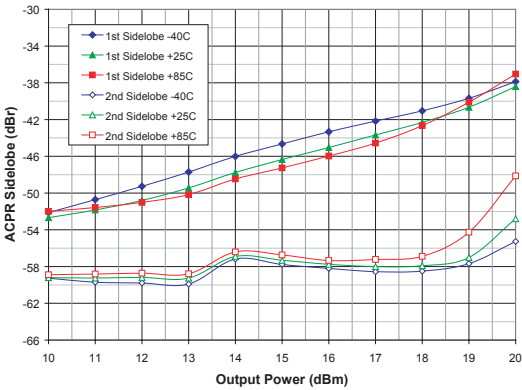

Figure 15: ACPR 1st and 2nd Sidelobes vs. Output Power Across Power Supply Voltage (Freq = 2.45 GHz, T_A = 25°C) 802.11b Root Cosine Filtering

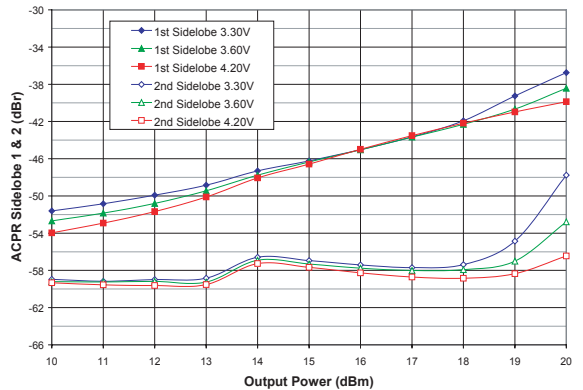

Figure 16: Detector Voltage vs. Output Power Across Freq (T_A = 25°C, V_{CC} = +3.6 V) 802.11b Root Cosine Filtering (α = 0.45), 1 Mbps

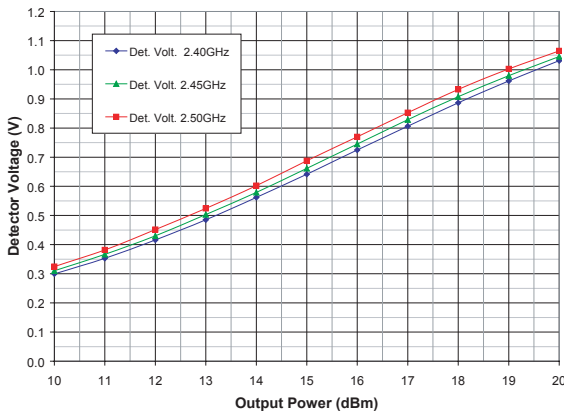

Figure 17: Detector Voltage vs. Output Power Across Temp (Freq = 2.45 GHz, V_{CC} = +3.6 V) 802.11b Root Cosine Filtering (α = 0.45), 1 Mbps

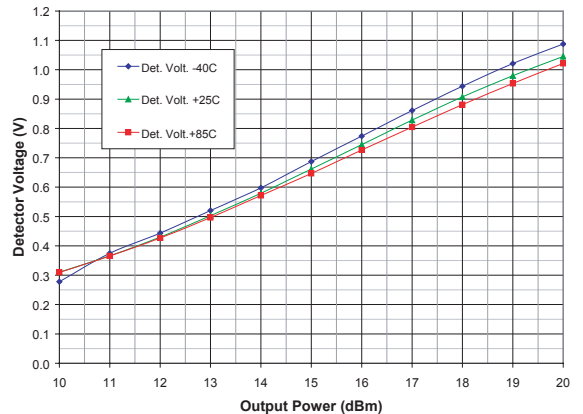

Figure 18: Tx Path S₂₁ Response (V_{CC} = +3.6 V, T_A = 25°C)

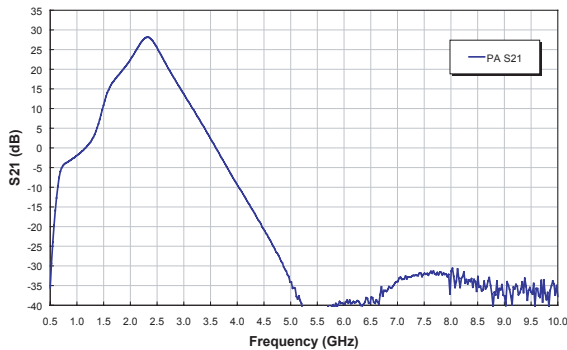

Figure 19: Tx Path Reverse Isolation (V_{CC} = +3.6 V, T_A = 25°C)

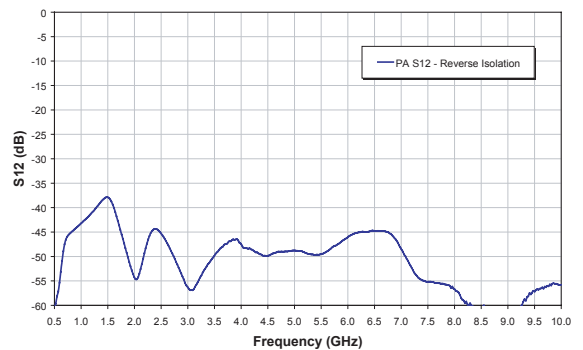

Figure 20: Tx Path Input & Output Return Losses
($V_{CC} = +3.6\text{ V}$, $T_A = 25^\circ\text{C}$)

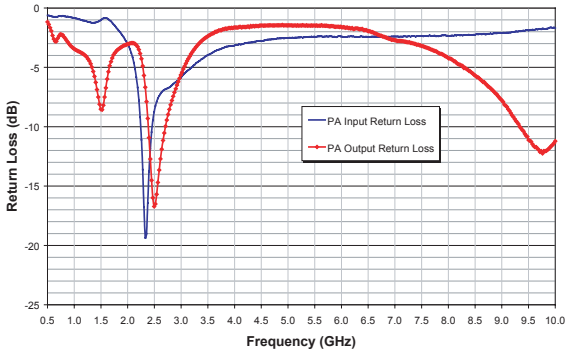

Figure 21: Rx Path S21 Response
($V_{CC} = +3.6\text{ V}$, $T_A = 25^\circ\text{C}$)

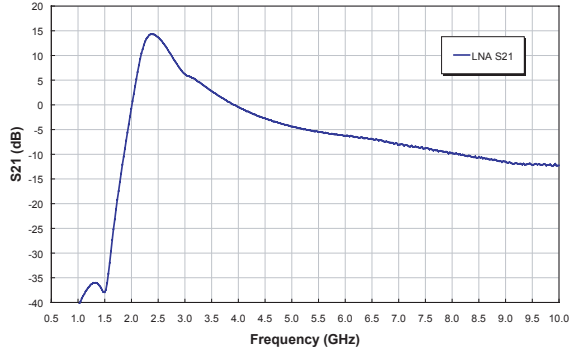

Figure 22: Rx Path Input & Output Return Losses
($V_{CC} = +3.6\text{ V}$, $T_A = 25^\circ\text{C}$)

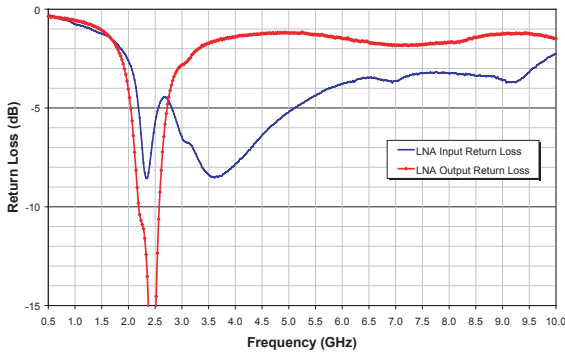

Figure 23: Bluetooth Path S21 Response
($V_{CC} = +3.6\text{ V}$, $T_A = 25^\circ\text{C}$)

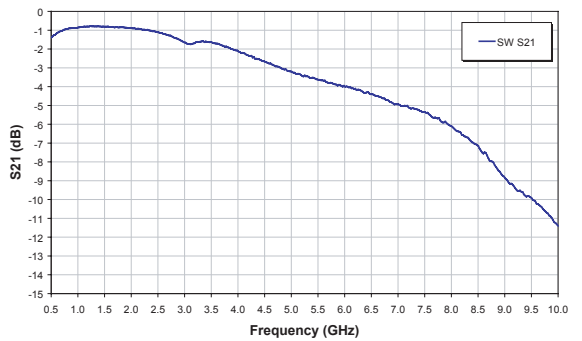
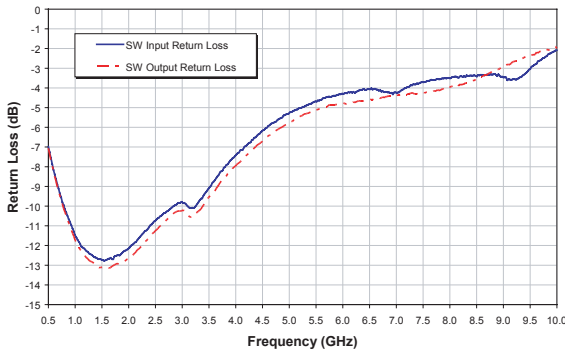
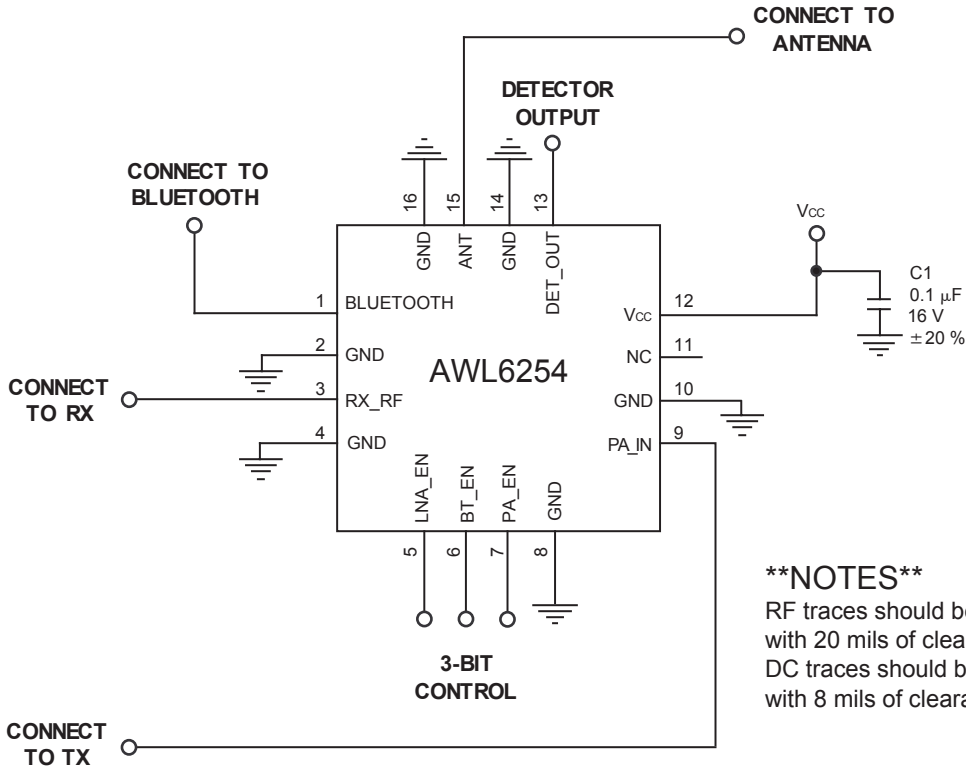

Figure 24: Bluetooth Path Input & Output Return Losses
($V_{CC} = +3.6\text{ V}$, $T_A = 25^\circ\text{C}$)



APPLICATION INFORMATION



****NOTES****

RF traces should be 18 mils wide with 20 mils of clearance.
DC traces should be 8 mils wide with 8 mils of clearance.

Figure 25: Application Circuit

PACKAGE OUTLINE

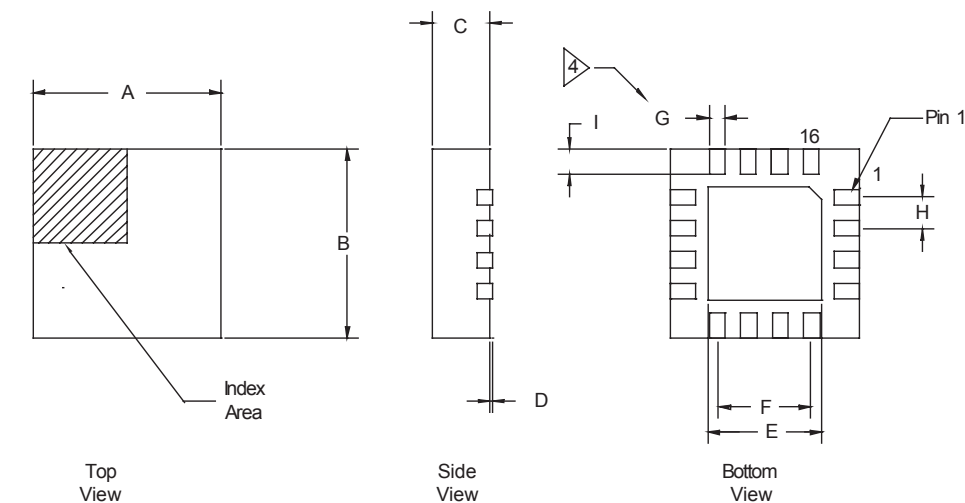

DIMENSION	MILLIMETERS		
	MIN	TYP	MAX
A	2.90	3.00	3.10
B	2.90	3.00	3.10
C	0.50	0.55	0.60
D	0.00	0.02	0.05
E	1.50	1.65	1.80
F	1.50 BSC.		
G	0.180	0.250	0.300
H	0.50 BSC.		
I	0.35	0.40	0.45

1. All dimensions are in millimeters, angles in degrees.
2. The terminal #1 identifier and pad numbering convention shall conform to JESD 95-1 SPP-012
3. Lead coplanarity: 0.05 max.
4. Dimension applies to metalized pad and is measured between 0.25 and 0.30 MM from pad tip.

Figure 26: S35 Package Outline - 16 Pin 3 mm x 3 mm x 0.55 mm ULPCC

TOP BRAND



NOTES:

1. ANADIGICS LOGO SIZE: N/A
2. PART NUMBER: AT = 2 DIGIT PART NUMBER
E = CURRENT ISSUE NUMBER OF BOM.
R = ROHS COMPLIANCE.
3. YEAR AND WORK WEEK: YWW = LAST DIGIT OF YEAR, TWO DIGIT WORK WEEK.
4. LOT NUMBER: ZZZ = LAST THREE NUMBERS OF WAFER LOT NUMBER
5. PIN 1 INDICATOR: MOLD NOTCH -or- INK DOT
6. COUNTRY CODE: N/A
7. TYPE : ELITE
SIZE : 1.5-POINT
COLOR : LASER

Figure 27: Branding Specification

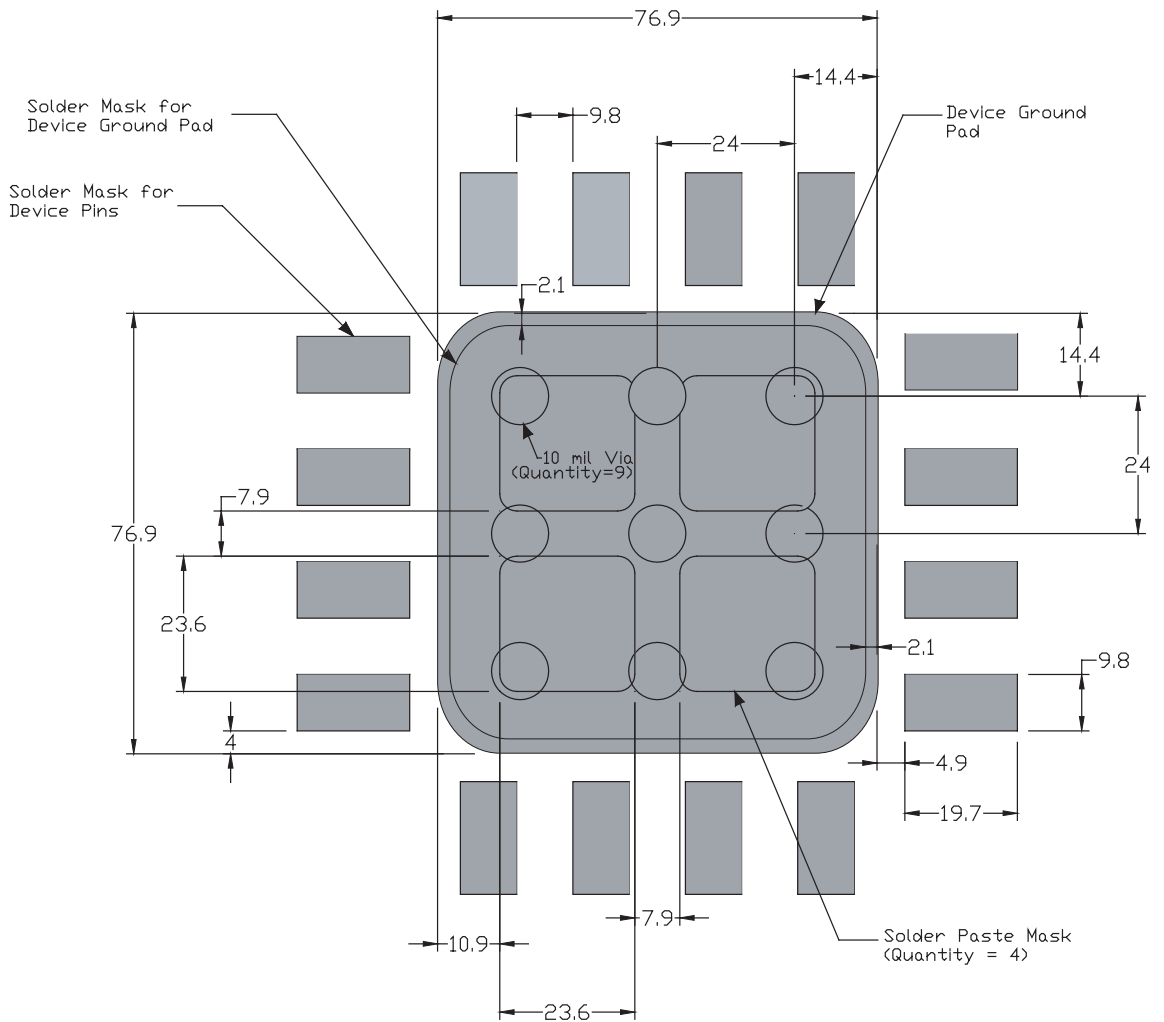

Figure 28: Recommended PCB Layout (all units are in mils)

NOTES

ORDERING INFORMATION

ORDER NUMBER	TEMPERATURE RANGE	PACKAGE DESCRIPTION	COMPONENT PACKAGING
AWL6254RS35Q1	-40 °C to +85 °C	RoHS-compliant 16 Pin 3 mm x 3 mm x 0.55 mm Surface Mount IC	1,000 piece Tape and Reel
AWL6254RS35P8	-40 °C to +85 °C	RoHS-compliant 16 Pin 3 mm x 3 mm x 0.55 mm Surface Mount IC	2,500 piece Tape and Reel
AWL6254RS35P0	-40 °C to +85 °C	RoHS-compliant 16 Pin 3 mm x 3 mm x 0.55 mm Surface Mount IC	1-999 piece Tubes
AWL6254RS35P6	-40 °C to +85 °C	RoHS-compliant 16 Pin 3 mm x 3 mm x 0.55 mm Surface Mount IC	1-999 piece Tray
AWL6254RD1Q4	-40 °C to +85 °C	RoHS-compliant Bare Die	6" Wafer on Film Frame
EVA6254RS35	-40 °C to +85 °C	RoHS-compliant 16 Pin 3 mm x 3 mm x 0.55 mm Surface Mount IC	1 piece Evaluation Board

**ANADIGICS, Inc.**

141 Mount Bethel Road
Warren, New Jersey 07059, U.S.A.

Tel: +1 (908) 668-5000

Fax: +1 (908) 668-5132

URL: <http://www.anadigics.com>

E-mail: Mktg@anadigics.com

IMPORTANT NOTICE

ANADIGICS, Inc. reserves the right to make changes to its products or to discontinue any product at any time without notice. The product specifications contained in Advanced Product Information sheets and Preliminary Data Sheets are subject to change prior to a product's formal introduction. Information in Data Sheets have been carefully checked and are assumed to be reliable; however, ANADIGICS assumes no responsibilities for inaccuracies. ANADIGICS strongly urges customers to verify that the information they are using is current before placing orders.

WARNING

ANADIGICS products are not intended for use in life support appliances, devices or systems. Use of an ANADIGICS product in any such application without written consent is prohibited.