

# **OKI Semiconductor**

---

## **MSM538031E**

---

1,048,576-Word x 8-Bit MASKROM

---

### DESCRIPTION

The OKI MSM538031E is a high-speed silicon gate CMOS Mask ROM with 1,048,576-word x 8-bit capacity. The MSM538031E operates on a single 3.0V or 3.3V power supply but offers the same fast access times as products that operate at 5.0V. The MSM538031E's bit-wide data path and pin compatibility with UV erasable EPROMs make it suited for use as large capacity fixed memory for portable microcomputers and data terminals.

### FEATURES

Single 3.0V or 3.3V power supply

1,048,576 word x 8 bit

Access time—current consumption

150ns—20mA (When power supply is 3.0V±0.3V)

120ns—25mA (When power supply is 3.3V±0.3V)

Tri-state output configurations

Internal powerdown function

Package:

32-PIN PLASTIC DIP (DIP32-P-600-2.54) (MSM538001E-XXRS)

32-PIN PLASTIC SOP (SOP32-P-525-1.27-K) (MSM538001E-XXGS-K)

32-PIN PLASTIC TSOP (TSOP32-P-814-0.50-1K) (MSM538001E-XXTS-K)

8MEPROM (32-PIN) pin compatible

### PIN CONFIGURATION

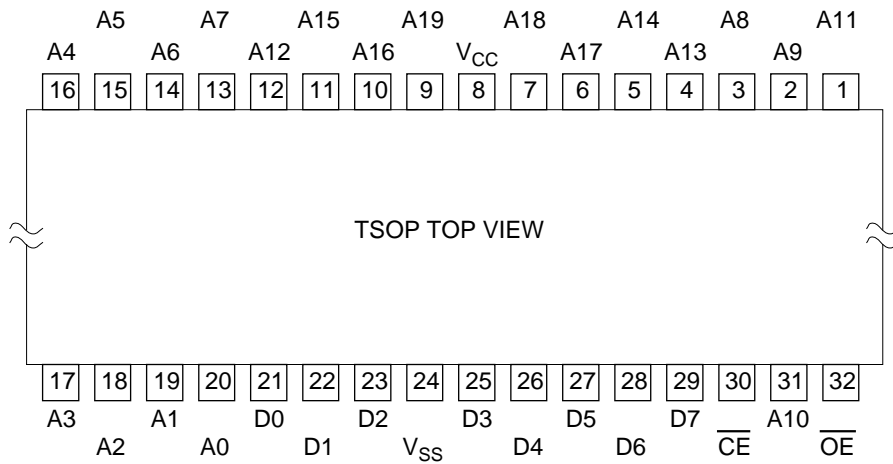
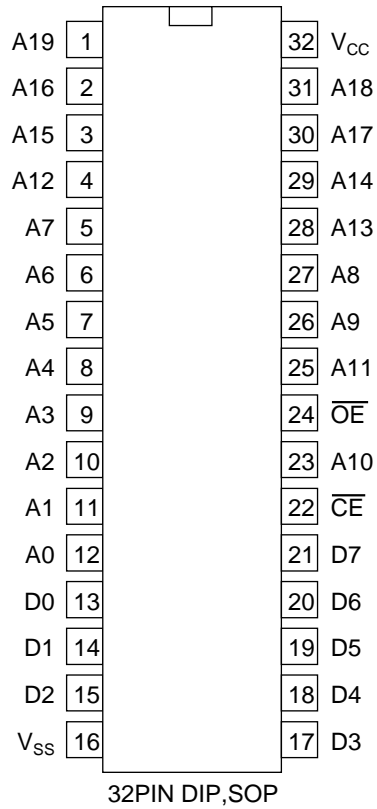

Pin Name	Function
A0 to A19	Address input
D0 to D7	Data output
$\overline{CE}$	Chip enable
$\overline{OE}$	Output enable
$V_{CC}, V_{SS}$	Power supply

## BLOCK DIAGRAM

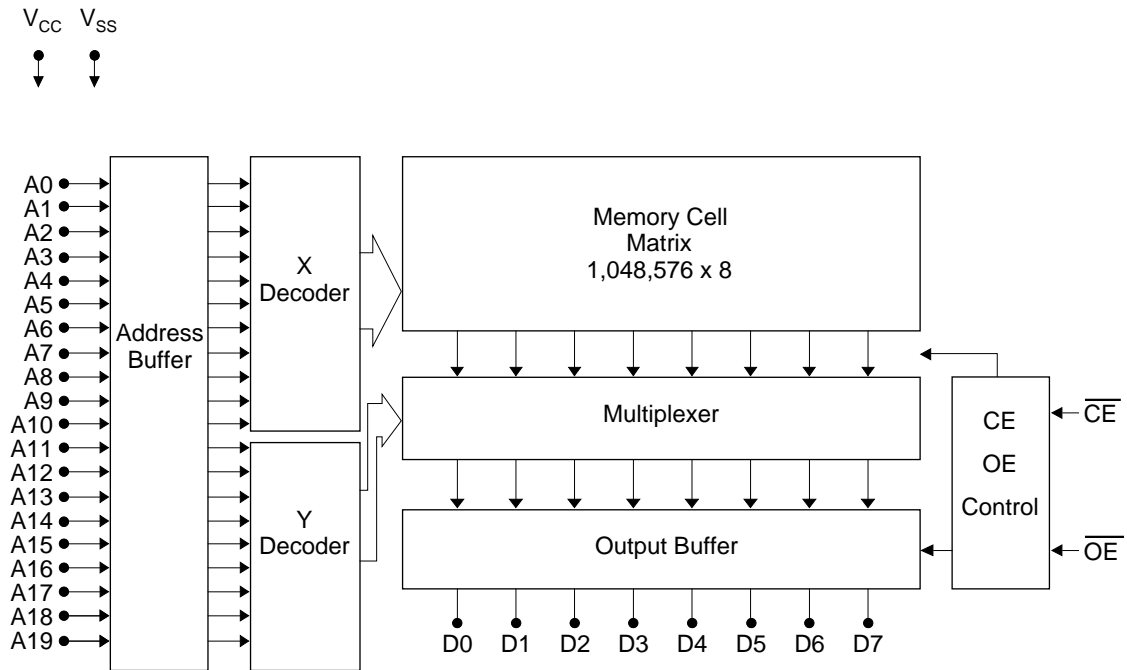

## ELECTRICAL CHARACTERISTICS

### Absolute Maximum Ratings

Parameter	Symbol	Conditions	Rating	Unit
Power Supply Voltage	$V_{CC}$	to $V_{SS}$	-0.3 to 7	V
Input Voltage	$V_I$		-0.3 to $V_{CC} + 0.5$	V
Output Voltage	$V_O$		-0.3 to $V_{CC} + 0.5$	V
Power Dissipation	$P_D$	Per Package $T_{opr} = 25^\circ\text{C}$	1.0	W
Operating Temperature	$T_{opr}$		0 to 70	$^\circ\text{C}$
Storage Temperature	$T_{stg}$		-55 to 150	$^\circ\text{C}$

### Recommended Operating Conditions ( $V_{CC}=3.0\text{V}$ )

Parameter	Symbol	Conditions	Rated Value			Unit
			Min.	Typ.	Max.	
Power Supply Voltage	$V_{CC}$	—	2.7	3.0	3.3	V
	$V_{SS}$	—	0.0	0.0	0.0	V
"H" Input Voltage	$V_{IH}$	—	2.0	3.0	6.0	V
"L" Input Voltage	$V_{IL}$	—	-0.3	0.0	0.6	V
Operating Temperature	$T_{opr}$	—	0	—	70	$^\circ\text{C}$

### Recommended Operating Conditions ( $V_{CC}=3.3\text{V}$ )

Parameter	Symbol	Conditions	Rated Value			Unit
			Min.	Typ.	Max.	
Power Supply Voltage	$V_{CC}$	—	3.0	3.3	3.6	V
	$V_{SS}$	—	0.0	0.0	0.0	V
"H" Input Voltage	$V_{IH}$	—	2.0	3.3	6.0	V
"L" Input Voltage	$V_{IL}$	—	-0.3	0.0	0.6	V
Operating Temperature	$T_{opr}$	—	0	—	70	$^\circ\text{C}$

DC CHARACTERISTICS ( $V_{CC}=3.0V\pm 0.3V$ )

(Ta = 0 to 70°C)

Parameter	Symbol	Conditions	Rated Value			Unit
			Min.	Typ.	Max.	
"H" Output Voltage	$V_{OH1}$	$I_{OH} = -100\mu A$	$V_{CC} - 0.1$	—	—	V
	$V_{OH2}$	$I_{OH} = -1.0mA$	$V_{CC} - 0.4$	—	—	V
"L" Output Voltage	$V_{OL1}$	$I_{OL} = 100\mu A$	—	—	0.1	V
	$V_{OL2}$	$I_{OI} = 1.0mA$	—	—	0.4	V
Input Leakage Current	$I_{LI}$	$V_I = 0$ to $V_{CC}$	-10	—	10	$\mu A$
Output Leakage Current	$I_{LO}$	$V_O = 0$ to $V_{CC}$ $\overline{CE} = V_{IH\ MIN}$	-10	—	10	$\mu A$
Power Supply Current (Operating)	$I_{CC}$	$\overline{CE} = V_{IL}, \overline{OE} = V_{IH}, t_C = 150ns$	—	—	20	mA
Power Supply Current (Standby)	$I_{CCS^C}$	$\overline{CE} = V_{CC} - 0.2V$	—	—	10	$\mu A$
	$I_{CCS^T}$	$\overline{CE} = V_{IH\ MIN}$	—	—	50	$\mu A$

DC CHARACTERISTICS ( $V_{CC}=3.3V\pm 0.3V$ )

(Ta = 0 to 70°C)

Parameter	Symbol	Conditions	Rated Value			Unit
			Min.	Typ.	Max.	
"H" Output Voltage	$V_{OH1}$	$I_{OH} = -100\mu A$	$V_{CC} - 0.1$	—	—	V
	$V_{OH2}$	$I_{OH} = -1.0mA$	$V_{CC} - 0.4$	—	—	V
"L" Output Voltage	$V_{OL1}$	$I_{OL} = 100\mu A$	—	—	0.1	V
	$V_{OL2}$	$I_{OI} = 1.0mA$	—	—	0.4	V
Input Leakage Current	$I_{LI}$	$V_I = 0$ to $V_{CC}$	-10	—	10	$\mu A$
Output Leakage Current	$I_{LO}$	$V_O = 0$ to $V_{CC}$ $\overline{CE} = V_{IH\ MIN}$	-10	—	10	$\mu A$
Power Supply Current (Operating)	$I_{CC}$	$\overline{CE} = V_{IL}, \overline{OE} = V_{IH}, t_C = 150ns$	—	—	25	mA
Power Supply Current (Standby)	$I_{CCS^C}$	$\overline{CE} = V_{CC} - 0.2V$	—	—	10	$\mu A$
	$I_{CCS^T}$	$\overline{CE} = V_{IH\ MIN}$	—	—	50	$\mu A$

## AC CHARACTERISTICS

Timing conditions

Parameter	Conditions
Input Signal Level	$V_{IH}=2.7V$ , $V_{IL}=0.0V$
Transition Time	$t_r=t_f=5ns$
Timing Reference Level	Input Voltage=1.5V Output Voltage=0.8V&2.0V
Load Condition	CL=50pF

Read Cycle ( $V_{CC}=3.0V\pm 0.3V$ )

(Ta = 0 to 70°C)

Parameter	Symbol	Conditions	Rated Value			Unit
			Min.	Typ.	Max.	
Cycle time	$t_C$	—	150	—	—	ns
Address Access time	$t_{ACC}$	—	—	—	150	ns
$\overline{CE}$ Access time	$t_{CE}$	—	—	—	150	ns
$\overline{OE}$ Access time	$t_{OE}$	—	—	—	80	ns
$\overline{CE}$ Output Disable time	$t_{CHZ}$	—	0	—	70	ns
$\overline{OE}$ Output Disable time	$t_{OHZ}$	—	0	—	60	ns
Output Hold time	$t_{OH}$	—	0	—	—	ns

Read Cycle ( $V_{CC}=3.0V\pm 0.3V$ )

(Ta = 0 to 70°C)

Parameter	Symbol	Conditions	Rated Value			Unit
			Min.	Typ.	Max.	
Cycle time	$t_C$	—	120	—	—	ns
Address Access time	$t_{ACC}$	—	—	—	120	ns
$\overline{CE}$ Access time	$t_{CE}$	—	—	—	120	ns
$\overline{OE}$ Access time	$t_{OE}$	—	—	—	70	ns
$\overline{CE}$ Output Disable time	$t_{CHZ}$	—	0	—	60	ns
$\overline{OE}$ Output Disable time	$t_{OHZ}$	—	0	—	50	ns
Output Hold time	$t_{OH}$	—	0	—	—	ns

## Read Cycle (Note 1)

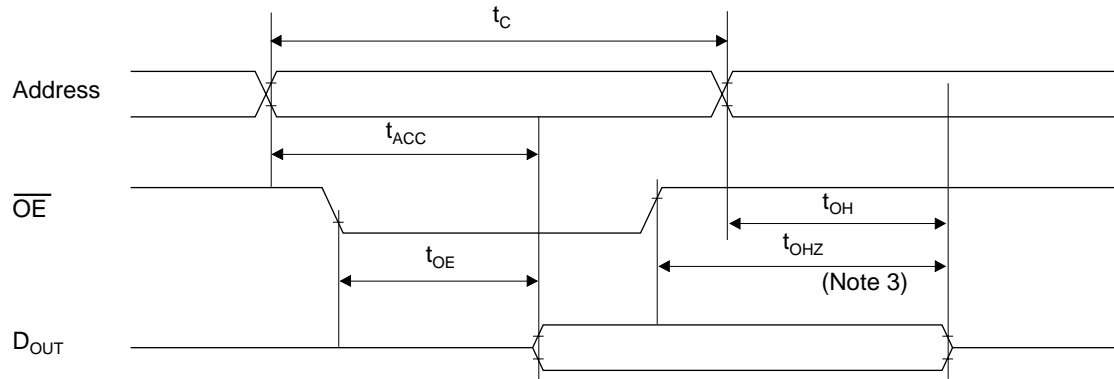

## Read Cycle (Note 2)

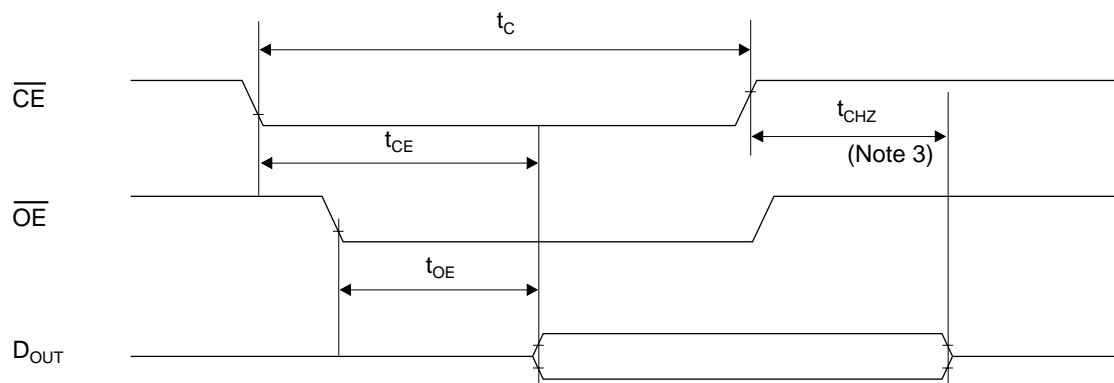

- Note )
1.  $\overline{CE}$  is low level.
  2. Address is fixed before or at the same time when  $\overline{CE}$  level falls.
  3.  $t_{CHZ}$  &  $t_{OHZ}$  indicate the time until floating. They are not determined by the output level.

## I/O CAPACITANCE

Parameter	Symbol	Conditions	Rated Value			Unit
			Min.	Typ.	Max.	
Input Capacitance	$C_I$	$V_I=0V$	—	—	8	pF
Output Capacitance	$C_O$	$V_O=0V$	—	—	10	pF

## **NOTICE**

The information contained herein can change without notice owing to product and/or technical improvements. Before using the product, please make sure that the information being referred to is up-to-date.

The outline of action and examples for application circuits described herein have been chosen as an explanation for the standard action and performance of the product. When planning to use the product, please ensure that the external conditions are reflected in the actual circuit, assembly, and program designs.

When designing your product, please use our product below the specified maximum ratings and within the specified operating ranges including, but not limited to, operating voltage, power dissipation, and operating temperature.

Oki assumes no responsibility or liability whatsoever for any failure or unusual or unexpected operation resulting from misuse, neglect, improper installation, repair, alteration or accident, improper handling, or unusual physical or electrical stress including, but not limited to, exposure to parameters beyond the specified maximum ratings or operation outside the specified operating range.

Neither indemnity against nor license of a third party's industrial and intellectual property right, etc. is granted by us in connection with the use of the product and/or the information and drawings contained herein. No responsibility is assumed by us for any infringement of a third party's right which may result from the use thereof.

The products listed in this document are intended for use in general electronics equipment for commercial applications (e.g., office automation, communication equipment, measurement equipment, consumer electronics, etc.). These products are not authorized for use in any system or application that requires special or enhanced quality and reliability characteristics nor in any system or application where the failure of such system or application may result in the loss or damage of property, or death or injury to humans. Such applications include, but are not limited to, traffic and automotive equipment, safety devices, aerospace equipment, nuclear power control, medical equipment, and life-support systems.

Certain products in this document may need government approval before they can be exported to particular countries. The purchaser assumes the responsibility of determining the legality of export of these products and will take appropriate and necessary steps at their own expense for these.

No part of the contents contained herein may be reprinted or reproduced without our prior permission.

All brand, company and product names are the trademarks or registered trademarks of their respective owners.

Copyright 1998 Oki Electric Industry Co., Ltd.  
Marketing Communications Team (RB)

# OKI

People To People Technology

## ADDRESSES & SEMICONDUCTOR WEB SITES

### **OKI Electric Industry Co., Ltd.,**

Device Business Group,  
10-3, Shibaura, 4-chome,  
Minato-ku, Tokyo 108, Japan,  
Tel.: +81-(0)3-5445-6327,  
Fax.: +81-(0)3-5445-6328,  
<http://www.oki.co.jp/semi/>

### **OKI Semiconductor Group,**

785 North Mary Avenue,  
Sunnyvale, CA 94086, U.S.A.,  
Tel.: +1-408-720-1900,  
Fax.: +1-408-720-1918,  
<http://www.okisemi.com/>

### **OKI Electric Europe GmbH,**

Head Office Europe,  
Hellersbergstrasse 2,  
D-41460 Neuss, Germany,  
Tel: +49-2131-15960,  
Fax: +49-2131-103539,  
<http://www.oki-europe.de/>

### **OKI Electronics (Hong Kong) Ltd.,**

Suite 1901-1&19, Tower 3,  
China Hong Kong City,  
33 Canton Road, Tsimshatsui,  
Kowloon, Hong Kong,  
Tel.: +852-2-736-2336,  
Fax.: +852-2-736-2395

### **OKI Semiconductor (Asia) Pte. Ltd.,**

78 Shenton Way 09-01,  
Singapore 0207,  
Tel.: +65-221-3722,  
Fax.: +65-323-5376

### **OKI Semiconductor (Asia) Pte. Ltd.,**

Taipei Branch,  
7th Fl. No.260, Tun Hwa North Road,  
Taipei, Taiwan, R.O.C.,  
Sumitomo-Flysun Building,  
Tel.: +886-2-2719-2561,  
Fax.: +886-2-2715-2892  
<http://www.oki.net.tw/>

*For further information, please contact:*