

M61113FP

Coil-less VIF/SIF

REJ03F0015-0100Z

Rev.1.00

Aug.25.2003

Description

The M61113FP is a semiconductor integrated circuit built-in the PLL inter-carrier method VIF/SIF dedicated to NTSC. The circuit includes the VIF amplifier, image waveform detection, APC detection, IF/RF, AGC, VCO, AFT, LOCK DET, EQ, AF amplifier, limiter, FM waveform detector circuits, and acts as a small tuner.

Features

- Built-in VCO coil for intermediate frequency signal processing
- AFT adjustment is not required and flat temperature characteristics is realized
- Reference frequency of 3.58 MHz/4.00 MHz
- Image intermediate frequency US (47.75 MHz)/JP (58.75 MHz)
- VIF/SIF mute function Coil-Less VIF/SIF

Recommended Operating Conditions

- Power-supply voltage range: 4.75 to 5.25 V
- Recommended power-supply voltage: 5.0 V

Application

- TV, VCR

Pin Configuration

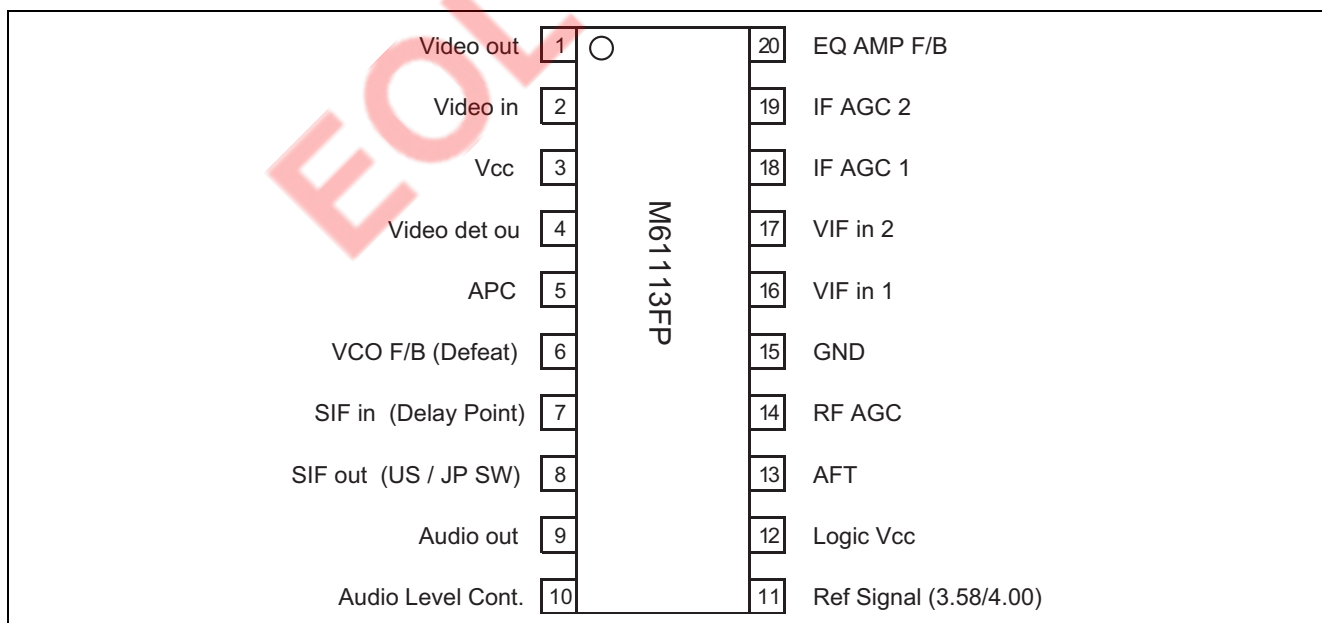

Block Diagram

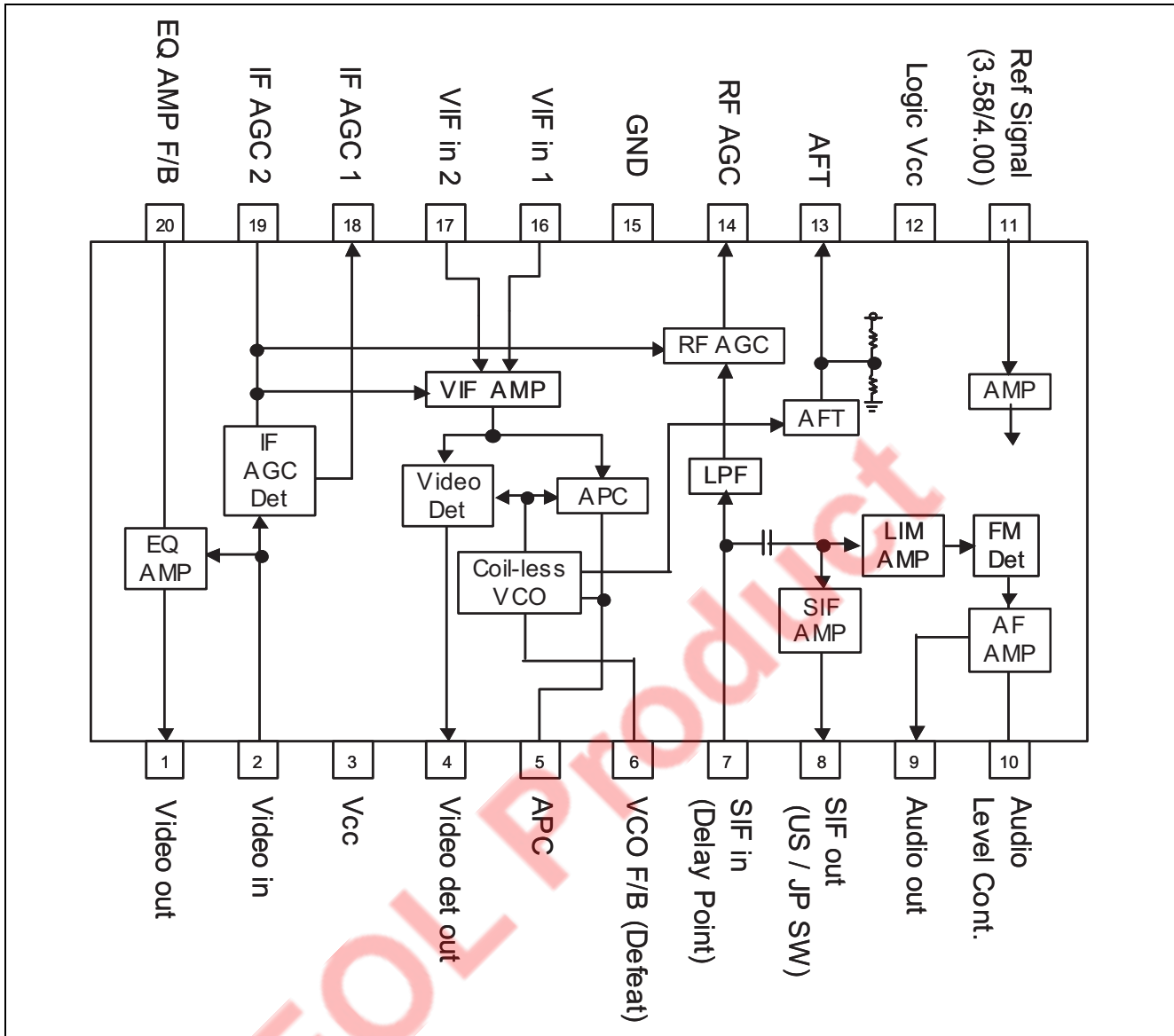

Absolute Maximum Ratings

(25°C, unless otherwise noted)

Parameter	Symbol	Ratings	Unit
Supply voltage	V _{cc}	6.0	V
Total power dissipation	P _d	969	mW
Operating temperature	T _{opr1}	-20 to 75	°C
Storage temperature	T _{stg}	-40 to 150	°C

Temperature Characteristics (Maximum Ratings)

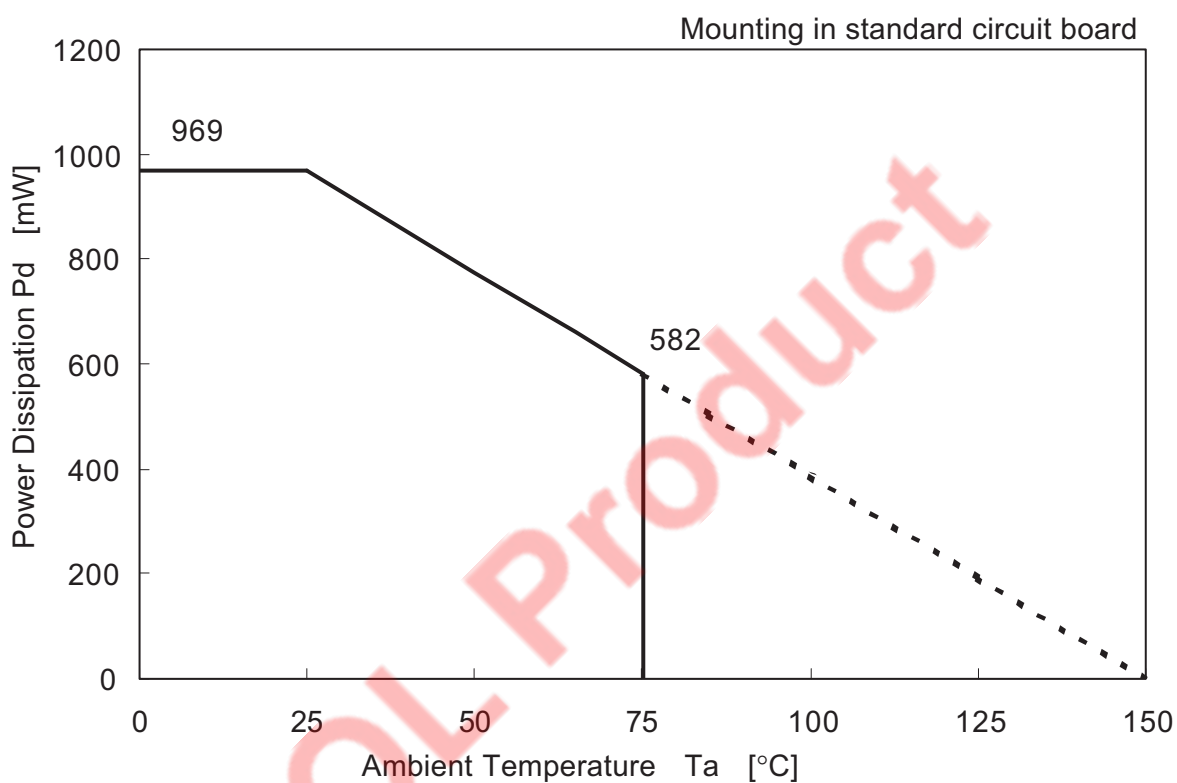

Recommended Operating Conditions

(Ta = 25°C, unless otherwise noted)

Parameter	Terminal #	Ratings	Unit
Supply voltage	3, 12	5.0	V
Functional supply voltage range	3, 12	4.75 to 5.25	V
Reference Frequency	11	3.579545	MHz
GND	15	GND	—

Pin Function

Pin No.	Pin Name	Function	Equivalent Circuit
1	Video out	Video out terminal.	
2	Video in	This terminal is input the video signal from Pin4 "Video det out" by SIF trap. Input this terminal to DC of Video det signal is necessary for IF AGC function.	
3	Vcc	Power supply terminal for VIF and SIF.	
4	Video det out	Video detector output terminal. SIF trap and SIF BPF are connected to this terminal. It is necessary connecting external resistor for drive, because open emitter configuration.	
5	APC	APC filter terminal.	
6	VCO F/B	VCO Feedback terminal. The feedback control is to keep the internal VCO of the uniform free-running frequency. This terminal has dual function, connecting to gnd select mode with VIF/SIF defeat.	

Pin Function (cont)

Pin No.	Pin Name	Function	Equivalent Circuit
7	SIF in (Delay Point)	RF AGC Delay terminal. 4.5 MHz SIF signal "LIM IN" is input at this pin which has dual function. The RF AGC Delay Point is set up of DC component is FM signal.	
8	SIF out (US/JP SW)	SIF output terminal. FM signal which is converted to 4.5 MHz is output. This pin has dual function of being VIF VCO type selection terminal. Connect to GND with 1.5 kΩ; JPN "58.75 MHz" No connect; USA "45.75 MHz"	
9	Audio out	Sound output terminal. De-emphasis is achieved by external components.	
10	Audio Level Cont.	AF Bypass terminal. It is connected to one of the input of a differential amplifier, external capacitor provides AC filtering. When resistor is connected in series with capacitor, it is possible to lower the amplitude of the audio output. when audio output terminal is not use, please connect this terminal to GND.	
11	Ref Signal (3.58/4.00)	Reference signal input terminal. It is input external signal with sinewave. In case of 4 MHz mode, connect to GND with 4.7 kΩ.	
12	Logic Vcc	Power supply terminal for Logic and Ref amp.	

Pin Function (cont)

Pin No.	Pin Name	Function	Equivalent Circuit
13	AFT	AFT output terminal. Because of pulse-like signal output, Smoothing capacitor is connected externally.	
14	RF AGC	RF AGC output terminal. It is current drive type.	
15	GND	Ground terminal for VIF and SIF.	
16	VIF in 1	IF signal after SAW filter is input.	
17	VIF in 2	It is balance-type input.	
18	IF AGC 1	IF AGC filter terminal 1. External capacitor affects AGC speed. Where this terminal is grounded, the effect of VIF amp, becomes minimum gain.	
19	IF AGC 2	IF AGC filter terminal 2.	
20	EQ AMP F/B	Equalizer feedback terminal. It is possible to change the AC response of the video signal by attaching L, C, R to this terminal.	

Electrical Characteristics

General

(Unless otherwise specified: Ta = 25°C, Vcc = 5.0 V, Ref Signal = 3.579545 MHz, Vi = 100 mVpp, SW = 1)

No.	Parameter	Symbol	Test circuit	Test point	Input point	Input signal	SW condition	Limits			Unit	Note#
								Min	Typ	Max		
1	VIF/SIF Vcc current	lcc1	1	Pin3	—	—	—	44	63	82	mA	
2	Logic Vcc Current	lcc2	1	Pin12	—	—	—	3.2	4.7	6.1	mA	
3	VIF/SIF Vcc current@Defeat	lcc3	1	Pin3 Pin12	—	—	SW6=2	6.3	9.0	12.0	mA	
4	Ref. signal input level	Fref	1	Pin11	Pin11	—	—	50	100	600	mVpp	

VIF Section 1

(Unless otherwise specified: Ta = 25°C, Vcc = 5.0 V, Ref Signal = 3.579545 MHz, Vi = 100 mVpp, SW = 1)

No.	Parameter	Symbol	Test circuit	Test point	Input point	Input signal	SW condition	Limits			Unit	Note#
								Min	Typ	Max		
5	Video out	Vodet	1	TP1	Pin16, 17	SG1	—	0.95	1.20	1.45	Vpp	
6	Sync Tip level	Vsync	1	TP1	Pin16, 17	SG2	—	1.20	1.45	1.70	V	
7	Video S/N	VoS/N	1	TP1	Pin16, 17	SG2	SW10=2	48	50	—	dB	1
8	Video Out Freq. response	BW	1	TP1	Pin16, 17	SG3	—	6	7	—	MHz	2
9	Input sensitivity	VinMIN	1	TP1	Pin16, 17	SG4	—	—	45	52	dBuV	3
10	Max. IF input	VinMAX	1	TP1	Pin16, 17	SG5	—	101	105	—	dBuV	4
11	IF AGC Range	GR	1	—	—	—	—	49	60	—	dB	5
12	IF AGC voltage @80 dBuV	IFAGC	1	TP19	Pin16, 17	SG6	—	2.7	3.0	3.3	V	
13	Capture range U	CR-U	1	TP1	Pin16, 17	SG7	—	0.80	1.00	—	MHz	6
14	Capture range L	CR-L	1	TP1	Pin16, 17	SG7	—	1.38	1.75	—	MHz	7
15	Inter modulation	IM	1	TP1	Pin16, 17	SG8	—	32	38	—	dB	8
16	D/G	DG	1	TP4	Pin16, 17	SG9	—	—	3	5	%	
17	D/P	DP	1	TP4	Pin16, 17	SG9	—	—	3	5	deg	
18	RF AGC High voltage	RFagcH	1	TP14	Pin16, 17	SG10	SW7=3	4.4	4.7	5.0	V	
19	RF AGC Low voltage	RFagcL	1	TP14	Pin16, 17	SG11	SW7=3	0	0.3	0.6	V	
20	RF AGC delay point	RFDP	1	TP14	Pin16, 17	SG12	SW7=3	82	85	88	dBuV	9

VIF Section 2

(Unless otherwise specified: Ta = 25°C, Vcc = 5.0 V, Ref Signal = 3.579545 MHz, Vi = 100 mVpp, SW = 1)

No.	Parameter	Symbol	Test circuit	Test point	Input point	Input signal	SW condition	Limits			Unit	Note#
								Min	Typ	Max		
21	AFT sensitivity	μ	1	TP13	Pin16, 17	SG13		10	26	40	mV/ kHz	10
22	AFT High voltage	AFTH	1	TP13	Pin16, 17	SG14		4.3	4.7	5	V	10
23	AFT Low voltage	AFTL	1	TP13	Pin16, 17	SG15		0	0.3	0.7	V	10
24	AFT Mute voltage	AFTM	1	TP13	Pin16, 17	SG16		2.4	2.5	2.6	V	
25	AFT Center voltage @US mode	VaftUS	1	TP13	Pin16, 17	SG2		2.40	2.65	2.90	V	
26	AFT Center voltage @JP mode	VaftJP	1	TP13	Pin16, 17	SG17	SW8=2	2.60	2.87	3.15	V	

SIF Section

(Unless otherwise specified: Ta = 25°C, Vcc = 5.0 V, Ref Signal = 3.579545 MHz, Vi = 100 mVpp, SW = 1)

No.	Parameter	Symbol	Test circuit	Test point	Input point	Input signal	SW condition	Limits			Unit	Note#
								Min	Typ	Max		
27	AF output level	VoAF	1	TP9	Pin7	SG18	SW7=2	400	700	1000	mVrms	
28	AF output THD	THDAF	1	TP9	Pin7	SG18	SW7=2	—	0.4	0.9	%	
29	Audio S/N	AF S/N	1	TP9	Pin7	SG19	SW7=2 SW19=2	50	55	—	dB	11
30	Limiting sensitivity	LIM	1	TP9	Pin7	SG20 SG21	SW7=2 SW19=2	—	50	55	dBuV	12
31	SIF output level	SIFG	1	TP8	Pin7	SG19	SW7=2	90	96	102	dBuV	

VCO Section

(Unless otherwise specified: Ta = 25°C, Vcc = 5.0 V, Ref Signal = 3.579545 MHz, Vi = 100 mVpp, SW = 1)

No.	Parameter	Symbol	Test circuit	Test point	Input point	Input signal	SW condition	Limits			Unit	Note#
								Min	Typ	Max		
32	VIF VCO freerun @US mode	FvcfUS	1	TP13	—	—	SW10=2 SW13,19=2	-500	0	+500	kHz	13
33	VIF VCO freerun @JP mode	FvcfJP	1	TP13	—	—	SW8,10=2 SW13,19=2	-500	0	+500	kHz	13

Input Signal

SG	Termination with 50 ohm			
1	f0 = 45.75 MHz	Vi = 90 dBuV	fm = 20 kHz	AM = 77.8%
2	f0 = 45.75 MHz	Vi = 90 dBuV	CW	
3	f1 = 45.75 MHz	Vi = 90 dBuV	CW	Mixed signal
	f2 = Freq. Variable	Vi = 70 dBuV	CW	
4	f0 = 45.75 MHz	Vi = Variable	fm = 20 kHz	AM = 77.8%
5	f0 = 45.75 MHz	Vi = Variable	fm = 20 kHz	AM = 16.0%
6	f0 = 45.75 MHz	Vi = 80 dBuV	CW	
7	f0 = Freq. Variable	Vi = 90 dBuV	fm = 20 kHz	AM = 77.8%
8	f1 = 45.75 MHz	Vi = 90 dBuV	CW	Mixed signal
	f2 = 42.17 MHz	Vi = 80 dBuV	CW	
	f3 = 41.25 MHz	Vi = 80 dBuV	CW	
9	f0 = 45.75 MHz	Sync Tip Level = 90 dBuV		
	87.5% TV modulation 10 step waveform			
10	f0 = 45.75 MHz	Vi = 70 dBuV	CW	
11	f0 = 45.75 MHz	Vi = 100 dBuV	CW	
12	f0 = 45.75 MHz	Vi = Variable	CW	
13	f0 = Freq. Variable	Vi = 90 dBuV	CW	
14	f0 = 45.75-0.5 MHz	Vi = 90 dBuV	CW	
15	f0 = 45.75+0.5 MHz	Vi = 90 dBuV	CW	
16	f0 = 45.75+/-0.5 MHz	Vi = 90 dBuV	CW	
17	f0 = 58.75 MHz	Vi = 90 dBuV	CW	
18	f0 = 4.5 MHz	Vi = 90 dBuV	fm = 1 kHz +/- 25 kHz dev	
19	f0 = 4.5 MHz	Vi = 90 dBuV	CW	
20	f0 = 4.5 MHz	Vi = Variable	fm = 1 kHz +/- 25 kHz dev	
21	f0 = 4.5 MHz	Vi = Variable	CW	

Mode Select

(Recommended Condition: Ta = 25°C Vcc = 5.0 V)

IF Defeat select	6 pin condition	Recommendation
Un defeat	DC Open	—
Defeat	0 to 0.5 V	GND

US/JP select	8 pin condition	Recommendation
US	None	No resistance
JP	Pull down (1.0 kΩ +/-10%)	1 kΩ to GND

Ref signal select	11 pin condition	Recommendation
3.58 M	None	No resistance
4.00 M	Pull down (4.7 kΩ +/-10%)	4.7 kΩ to GND

SIF defeat select	10 pin condition	Recommendation
Un defeat	DC Open	—
Defeat	0 to 0.3 V	GND

Notes

Note 1 Video S/N: VoS/N

Input SG2 to VIF IN (Pin 16, 17) and measure the video out (TP1) noise in r.m.s. through a 5 MHz (–3 dB) L.P.F..

$$S/N = 20 \log \left(\frac{0.7 \times V_{odet} (V_{pp})}{NOISE (rms)} \right) \quad (dB)$$

Note 2 Video Band Width: BW

- Measure the 1 MHz component level of Video output TP4 with a spectrum analyzer when SG3 (f2 = 44.75 MHz) is input to VIF IN (Pin 16, 17).
- Reduce f2 and measure the value of (f1-f2) when the (f1-f2) component level reaches –3 dB from the 1 MHz component level as shown below.

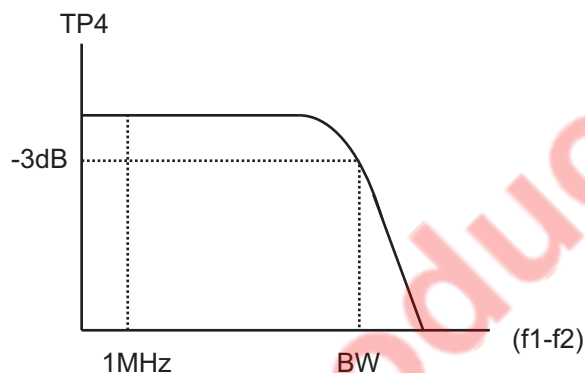

Note 3 Input Sensitivity: VIN MIN

Input SG4 (Vi = 90 dBu) to VIF IN (Pin 16, 17) and then gradually reduce Vi and measure the input level when the 20 kHz component of Video output TP1 reaches –3 dB from Vo det level.

Note 4 Maximum Allowable Input: VIN MAX

- Input SG5 (Vi = 90 dBu) to VIF IN (Pin 16, 17), and measure the level of the 20 kHz component of Video output (TP1).
- Gradually increase the Vi of SG and measure the input level when the output reaches –3 dB.

Note 5 AGC Control Range: GR

$$GR = V_{inMAX} - V_{inMIN} \quad (dB)$$

Note 6 Capture Range: CR-U

- Increase the frequency of SG7 until the VCO is out of locked-oscillation.
 - And decrease the frequency of SG7 and measure the frequency fU when the VCO is locked.
- $$CR - U = fU - 45.75 \quad (MHz)$$

Note 7 Capture Range: CR-L

- Decrease the frequency of SG7 until the VCO is out of locked-oscillation.
 - And increase the frequency of SG7 and measure the frequency fL when the VCO is locked.
- $$CR - L = 45.75 - fL \quad (MHz)$$

Note 8 Inter Modulation: IM

- Input SG8 to VIF IN (Pin 16, 17), and measure video output TP1 with an oscilloscope.
- Adjust AGC filter voltage TP19 so that the minimum DC level of the output waveform is Vsync.
- At that time, measure TP1 with a spectrum analyzer. The inter modulation is defined as a difference between 0.92 MHz and 3.58 MHz frequency components.

Note 9 RF AGC Delay Point (TV Mode): RFDP

- Input SG12 to VIF IN (Pin 16, 17) and gradually reduce level and then measure the input level when RF AGC output (TP14) reaches 1/2Vcc, as shown below.
- At that time, the state of Pin 7 is DC open.

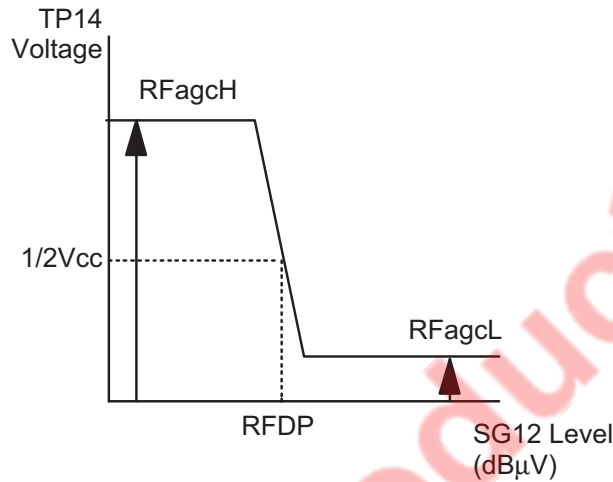

Note 10 AFT sensitivity: μ, Maximum AFT Voltage: AFTH, Minimum AFT Voltage: AFTL

- Input SG13 to VIF IN (Pin 16, 17) and set the frequency of SG13 so that the voltage of AFT output TP13 is 3 volt. The frequency is named f(3).
- Set the frequency of SG13 so that the AFT output voltage is 2 volt. This frequency is named f(2).
- In the graph shown below, maximum and minimum DC voltage are AFTH and AFTL, respectively.

$$\mu = \frac{1000}{f(2) - f(3)} \frac{(mV)}{(KHz)} \quad (mV/kHz)$$

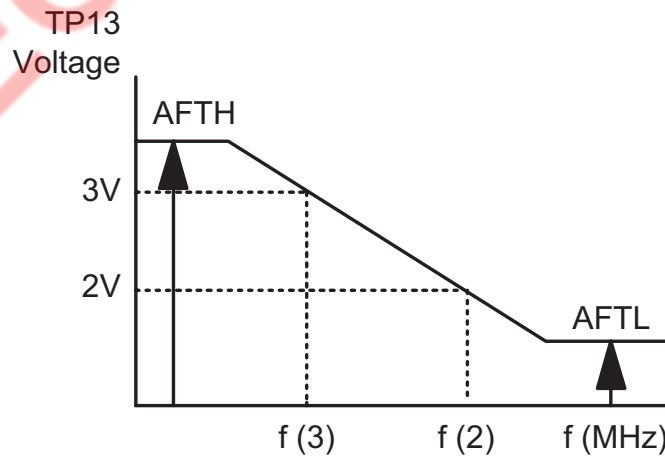

Note 11 Audio S/N: AF S/N

Input SG19 to SIF IN (Pin 7), and measure the output noise level of Audio output (TP9) with FLAT-r.m.s.. This level is named Vn1.

$$AF\ S/N = 20\log \left(\frac{VoAF1\ (mVrms)}{Vn1\ (mVrms)} \right) \quad (dB)$$

Note 12 Limiting Sensitivity: LIM

- Input SG20 to LIM IN, and measure the 1 kHz component level of AF output TP9 with FLAT-r.m.s..
- Input SG21 to LIM IN, and measure the noise level of AF output TP9 with FLAT-r.m.s..
- The input limiting sensitivity is defined as the input level when the difference between each 1 kHz components of audio output (TP9) is 30 dB, as shown below.

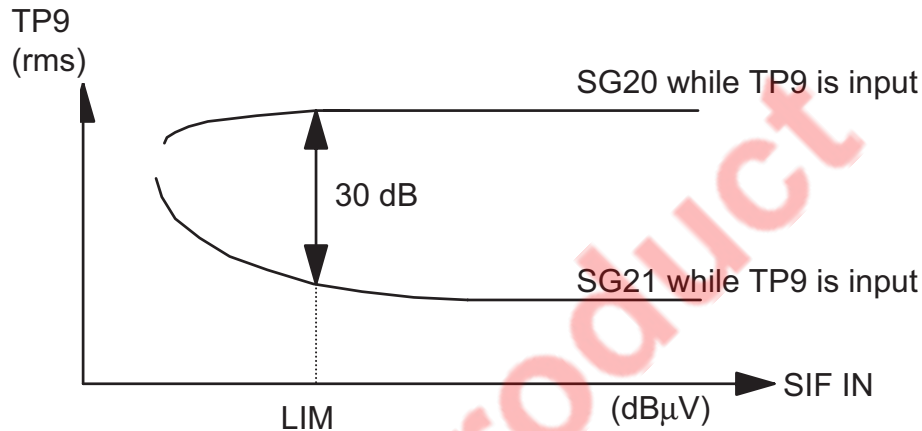

Note 13 VIF VCO Freerun Frequency: FvcfUS/FvcfJP

- Input 3.579545 MHz to Ref IN (Pin 11), and set up SW as shown following.

SW No.	US Mode		JP Mode		
	Setting	Condition	Setting	Condition	
20	3	Add to 2.5 V	3	Add to 2.5 V	*VCO SW: US/JP
8	1	No-Connecting R	2	Connecting 1 kΩ	#Fref SW
10	2	GND	2	GND	
11	1	No-Connecting R	1	No-Connecting R	
13	2	No-Connecting C	2	No-Connecting C	
19	2	GND	2	GND	

- Measure the frequency of output signal at AFT out (TP13) each when be selected US or JP by SW10.
- Measured frequency's are defined FaftUS (US Mode), FaftJP (JP Mode). The VCO freerun frequency is calculated by following.

<Fref = 3.579545 MHz>

- US Mode

$$FvcfUS = 52.915\ (MHz) - 2 \times FaftUS\ (MHz) - 45.75\ (MHz) \quad [MHz]$$

- JP Mode

$$FvcfJP = 65.925\ (MHz) - 2 \times FaftJP\ (MHz) - 58.75\ (MHz) \quad [MHz]$$

Package Dimensions

20P2F-A

(MMP)

Plastic 20pin 255mil SSOP

EIAJ Package Code SSOP20-P-255-0.65	JEDEC Code —	Weight(g) —	Lead Material Cu Alloy
--	-----------------	----------------	---------------------------

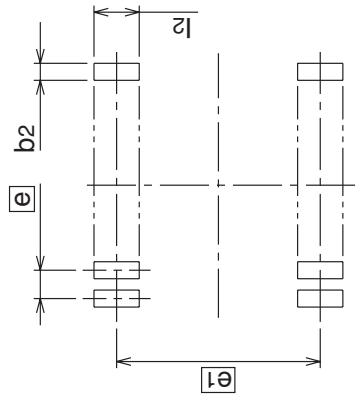
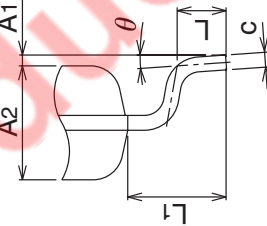
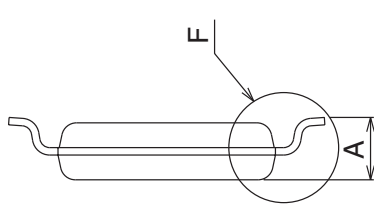
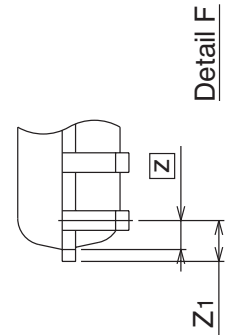
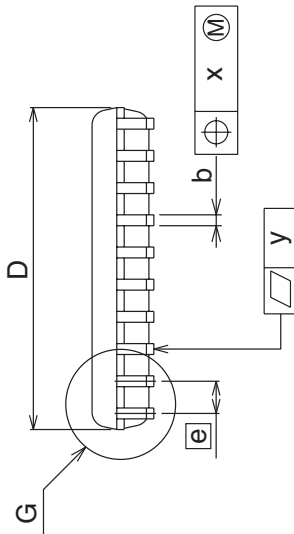
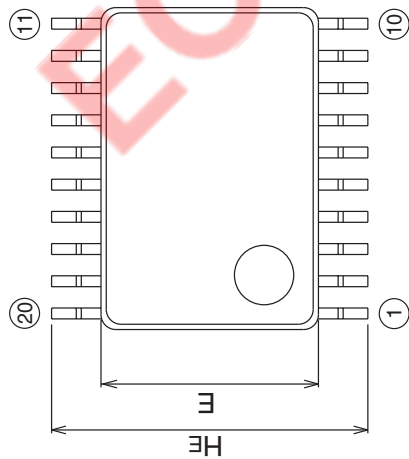

Recommended Mount Pad

Symbol	Dimension in Millimeters		
	Min	Nom	Max
A	—	—	1.45
A1	0	0.1	0.2
A2	—	1.15	—
b	0.17	0.22	0.32
c	0.13	0.15	0.2
D	6.4	6.5	6.6
E	4.3	4.4	4.5
e	—	0.65	—
HE	6.2	6.4	6.6
L	0.3	0.5	0.7
L1	—	1.0	—
Z	—	0.325	—
Z1	—	—	0.475
x	—	—	0.13
y	—	—	0.1
theta	0°	—	10°
b2	—	0.35	—
e1	—	5.8	—
l2	1.0	—	—

Renesas Technology Corp. Sales Strategic Planning Div. Nippon Bldg., 2-6-2, Ohte-machi, Chiyoda-ku, Tokyo 100-0004, Japan

Keep safety first in your circuit designs!

1. Renesas Technology Corp. puts the maximum effort into making semiconductor products better and more reliable, but there is always the possibility that trouble may occur with them. Trouble with semiconductors may lead to personal injury, fire or property damage.
Remember to give due consideration to safety when making your circuit designs, with appropriate measures such as (i) placement of substitutive, auxiliary circuits, (ii) use of nonflammable material or (iii) prevention against any malfunction or mishap.

Notes regarding these materials

1. These materials are intended as a reference to assist our customers in the selection of the Renesas Technology Corp. product best suited to the customer's application; they do not convey any license under any intellectual property rights, or any other rights, belonging to Renesas Technology Corp. or a third party.
 2. Renesas Technology Corp. assumes no responsibility for any damage, or infringement of any third-party's rights, originating in the use of any product data, diagrams, charts, programs, algorithms, or circuit application examples contained in these materials.
 3. All information contained in these materials, including product data, diagrams, charts, programs and algorithms represents information on products at the time of publication of these materials, and are subject to change by Renesas Technology Corp. without notice due to product improvements or other reasons. It is therefore recommended that customers contact Renesas Technology Corp. or an authorized Renesas Technology Corp. product distributor for the latest product information before purchasing a product listed herein.
The information described here may contain technical inaccuracies or typographical errors.
Renesas Technology Corp. assumes no responsibility for any damage, liability, or other loss rising from these inaccuracies or errors.
Please also pay attention to information published by Renesas Technology Corp. by various means, including the Renesas Technology Corp. Semiconductor home page (<http://www.renesas.com>).
 4. When using any or all of the information contained in these materials, including product data, diagrams, charts, programs, and algorithms, please be sure to evaluate all information as a total system before making a final decision on the applicability of the information and products. Renesas Technology Corp. assumes no responsibility for any damage, liability or other loss resulting from the information contained herein.
 5. Renesas Technology Corp. semiconductors are not designed or manufactured for use in a device or system that is used under circumstances in which human life is potentially at stake. Please contact Renesas Technology Corp. or an authorized Renesas Technology Corp. product distributor when considering the use of a product contained herein for any specific purposes, such as apparatus or systems for transportation, vehicular, medical, aerospace, nuclear, or undersea repeater use.
 6. The prior written approval of Renesas Technology Corp. is necessary to reprint or reproduce in whole or in part these materials.
 7. If these products or technologies are subject to the Japanese export control restrictions, they must be exported under a license from the Japanese government and cannot be imported into a country other than the approved destination.
Any diversion or reexport contrary to the export control laws and regulations of Japan and/or the country of destination is prohibited.
 8. Please contact Renesas Technology Corp. for further details on these materials or the products contained therein.
-



RENESAS SALES OFFICES

<http://www.renesas.com>

Renesas Technology America, Inc.
450 Holger Way, San Jose, CA 95134-1368, U.S.A
Tel: <1> (408) 382-7500 Fax: <1> (408) 382-7501

Renesas Technology Europe Limited.
Dukes Meadow, Millboard Road, Bourne End, Buckinghamshire, SL8 5FH, United Kingdom
Tel: <44> (1628) 585 100, Fax: <44> (1628) 585 900

Renesas Technology Europe GmbH
Dornacher Str. 3, D-85622 Feldkirchen, Germany
Tel: <49> (89) 380 70 0, Fax: <49> (89) 929 30 11

Renesas Technology Hong Kong Ltd.
7/F., North Tower, World Finance Centre, Harbour City, Canton Road, Hong Kong
Tel: <852> 2265-6688, Fax: <852> 2375-6836

Renesas Technology Taiwan Co., Ltd.
FL 10, #99, Fu-Hsing N. Rd., Taipei, Taiwan
Tel: <886> (2) 2715-2888, Fax: <886> (2) 2713-2999

Renesas Technology (Shanghai) Co., Ltd.
26/F., Ruijin Building, No.205 Maoming Road (S), Shanghai 200020, China
Tel: <86> (21) 6472-1001, Fax: <86> (21) 6415-2952

Renesas Technology Singapore Pte. Ltd.
1, Harbour Front Avenue, #06-10, Keppel Bay Tower, Singapore 098632
Tel: <65> 6213-0200, Fax: <65> 6278-8001