

# Voice Storage Controller

## Features

- Single chip voice controller
- Message management
- Flash memory interface—parallel
- Intelligent power management
- Over 14 minutes of speech storage in 8 Mbit Flash
- ADPCM compression/decompression
- Provides audio and LED feedback to user.
- Customizable ROM

## Applications

- Voice memo recorders, dictaphones
- Automatic call distribution system
- Cell phone answering machines
- Electronic Information Tags
- Electronic Organizers

## General Description

The TriTech TR83100 is designed in advanced CMOS technology for use in voice storage applications. Incorporating all blocks required in the digitization, storage and playback of voice signals, it interfaces directly to a microphone for voice input and a speaker for voice playback with minimal external components. An on-board compression and decompression engine works in conjunction with a memory controller to allow the voice data to be stored in parallel flash memory. A sophisticated message management scheme allows a voice recorder to be implemented by simply connecting suitable memory.

## Block Diagram

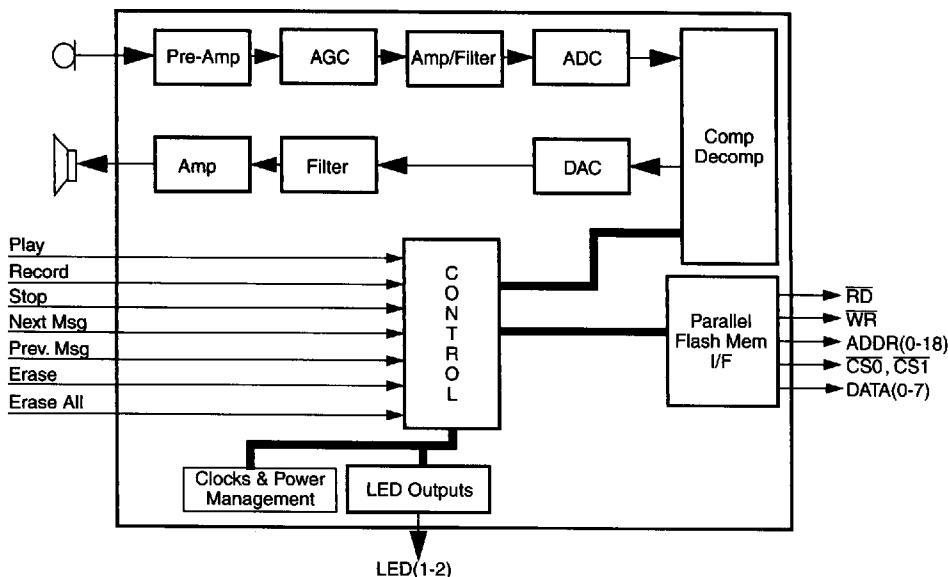

Figure 1 • TR83100 Voice Storage Controller

Pin Configuration

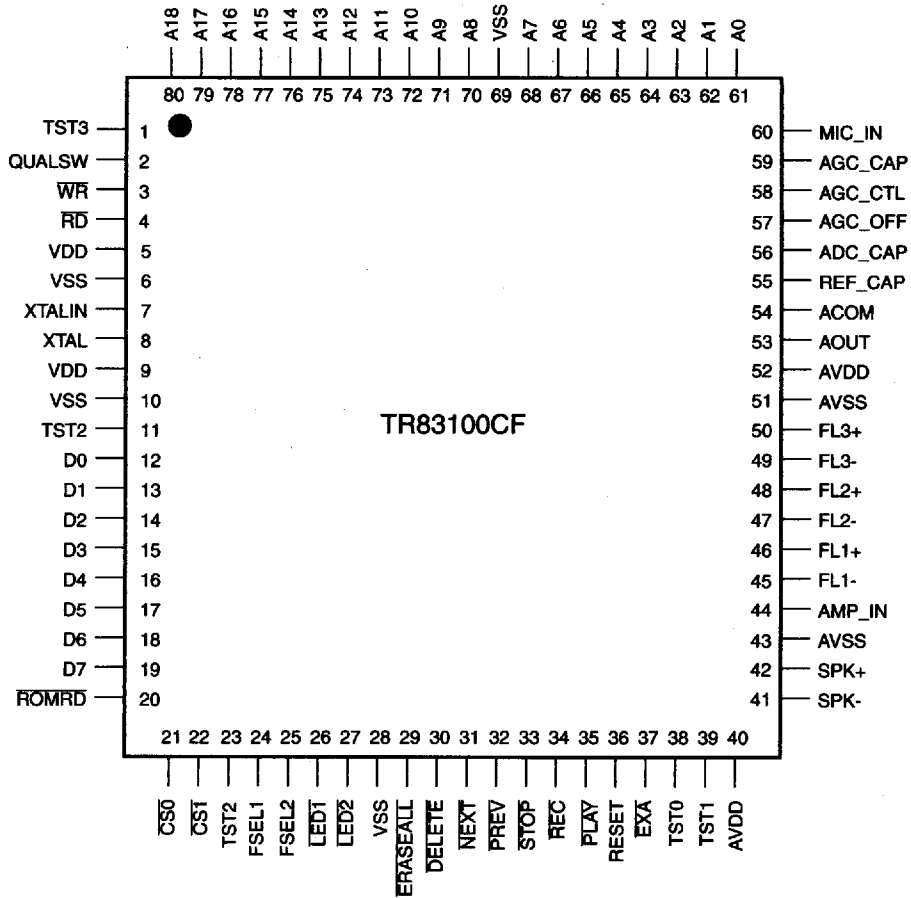

Figure 2 • Package Pin Layout, Top View

## Pin Descriptions

Pin No	Pin Name	I/O	Description
1	TST3		Do not use. Leave unconnected
2*	QUALSW	DI‡	Quality switch. H=20kb/s, L=10kb/s
3	WR	DO‡	Write strobe
4	RD	DO‡	Read strobe
5	VDD	DP	Digital power
6	VSS	DP	Digital ground
7	XTALIN	DI	Oscillator input
8	XTAL	DO	Oscillator pin
9	VDD	DP	Digital power
10	VSS	DP	Digital ground
11	TST2	DI	Test Pin. Connect to GND
12-19	D(0:7)	D/I/O‡	Data Bus
20	ROMRD	DO‡	External ROM strobe
21	CS0	DO†	Chip sel. for flash
22	CS1	DO†	Chip sel. for flash
23	TST2	DI	Test pin, leave unconnected
24*	FSEL1	DI‡	Flash Type Select 1
25*	FSEL2	DI‡	Flash Type Select 2
26	LED1	DO‡	LED output
27	LED2	DO‡	LED output
28	VSS	DP	Digital ground
29	ERASEALL	DI‡	Erase all messages
30	DELETE	DI‡	Erase current message
31	NEXT	DI‡	Point to next message
32	PREV	DI‡	Previous message
33	STOP	DI‡	Stop play or record
34	REC	DI‡	Record
35	PLAY	DI‡	Play
36	RESET	DI†	Reset input, active high

Pin No	Pin Name	I/O	Description
37*	EXA	DI‡	External ROM access
38	TST0	DI‡	Test pin. Connect to GND
39	TST1	DI‡	Test pin. Connect to GND
40	AVDD	AP	Analog power
41	SPK-	AO	Speaker output
42	SPK+	AO	Speaker output
43	AVSS	AP	Analog ground
44	AMP_IN	AI	Pwr. amp inp. AC coupled
45	FL1-	AI/O	Filter opamp1 -ve input
46	FL1+	AI	Filter opamp1 +ve input
47	FL2-	AI/O	Filter opamp2 -ve input
48	FL2+	AI	Filter opamp2 +ve input
49	FL3-	AI/O	Filter opamp3 -ve input
50	FL3+	AI	Filter opamp3 +ve input
51	AVSS	AP	Analog ground
52	AVDD	AP	Analog power
53	AOUT	AO	Audio output to Filter
54	ACOM	AI/O	Analog Common
55	REF_CAP	AI/O	External reference cap
56	ADC_CAP	AI/O	ADC external cap
57*	AGC_OFF	AI†	AGC Off option.
58	AGC_CTL	AI/O	AGC release time control
59	AGC_CAP	AI/O	AGC external cap
60	MIC_IN	AI	Mic input, AC coupled
61-68	A<0:7>	DO†	Address lines
69	VSS	DP	Digital ground
70-77	A<8:15>	DO†	Address lines
78-80	A<16:18>	DO‡	Address lines

Note: Connect pins marked \* to either Vdd or Vss depending on functionality †CMOS ‡TTL

### TR83100 System Operation

The TR83100 provides a sophisticated message management control scheme. All user interface commands, i.e. the PLAY, RECORD, NEXT, PREVIOUS, STOP, ERASE, and ERASE ALL, are available as dedicated control input pins. Figure 3 shows the stand alone system. The TR83100 provides a complete message management scheme that allows it to offer capabilities that are similar to the 'voice mail' systems currently available. The TR83100 offers random access and control of messages. The implementation is based upon the concept of a message pointer that is used to address voice messages of varying lengths. Once a voice message has been addressed, it can be played or erased. New voice messages are always added at the end of the list by issuing a record command.

The commands are briefly described below.

**PLAY:**

The voice message currently addressed by the message pointer is played. Message play can be stopped with a STOP command, or another PLAY command, or when the end of the message is encountered. LED1 is turned ON whenever a message is played.

**RECORD:**

A new voice message is always recorded at the end of a list of messages, and this message becomes current. Recording can be terminated with a STOP command, or another RECORD command, or when the system runs out of storage space. LED2 is turned ON during recording.

**STOP:**

Stops playing or recording.

**ERASE:**

Erases the voice message addressed by the message pointer and the next message becomes current. If last message is deleted, the previous message in the list becomes current. LED2 blinks once.

**ERASE ALL:**

Erases all voice messages and resets the message pointer. LED2 is turned ON and blinks three times after completion.

**NEXT:**

Skip to the next message by incrementing the message pointer when the system is in IDLE

mode. If the next message is available then LED1 blinks once, otherwise LED2 will blink once.

During Playback, if the NEXT command is issued for less than 0.5 second, the next message is automatically played. But if the NEXT button is held LOW for more than 0.5 second, FAST PLAYBACK (150%) occurs. FAST PLAYBACK will continue as long as the NEXT button is being held LOW.

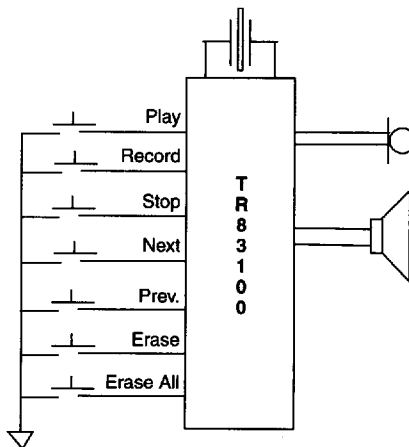

Figure 3 • Switch Functions

**PREVIOUS:**

Skip to the previous message by decrementing the message pointer when the system is in IDLE mode. If the next message is available then LED1 blinks once, otherwise LED2 will blink once.

During Playback, if the PREVIOUS command is issued for less than 0.5 second, the current message will be played from the start. If the PREVIOUS command is issued twice within the interval of 0.5 second then the previous message will be played. If the PREVIOUS command is issued for more than 0.5 second, SLOW PLAYBACK (80%) occurs. SLOW PLAYBACK will continue as long as the PREVIOUS button is being held LOW.

The debouncing time for all the commands is 30 milliseconds except ERASE and ERASE ALL commands. ERASE and ERASE ALL buttons need to be held LOW for 0.5 second and 1.0 second respectively for them to be activated.

An optional buzzer tone (1000 Hz, 100ms) which gives audible feedback, is generated when any key

is pressed. These tones can be disabled/enabled by pressing down the NEXT key for 2 seconds in IDLE mode.

### Device Description

The TR83100 is a voice record and playback device. It includes on it the analog front end required to interface directly to an electret microphone, the analog back end required to interface directly to a speaker, the compression/decompression engine required to pack the voice data, the control section required to provide the message management and finally the memory interface required to communicate with the flash memory. The compression/decompression engine is a 20/10 Kbps ADPCM algorithm.

The Analog front end (AFE) consists of an input amplifier stage, an automatic gain control stage, an input filter and the A/D converter stage.

Automatic gain control normalizes the signal from the microphone in the range of 30mV to 200mV in order to compensate for any positional differences of the microphone to the speaker. AGC can be turned off, if desired, and a fixed gain of 20 dB (i.e.  $G=10$ ) can be inserted in its place by connecting AGC\_OFF to VDD. AGC output is available at the AOUT pin when a message is being recorded.

The speech signal from AOUT pin is passed through a three stage low pass sixth order active filter. Three internal unity gain OpAmps can be used in a Sallen Key configuration to implement a sixth order Low pass filter. The characteristics of the filter are controlled through external resistors and capacitors. The filter section is common to both the AFE and the ABE. The filtered signal is fed into a 10-bit linear A/D converter. The OpAmps could be used to implement fourth or fifth order filters too.

The Analog back end (ABE) consists of the D/A converter, output filter and the output amplifier stage.

An 8 bit D/A converter drives the active filter. A power amplifier stage is used to directly drive a 32 ohm low cost speaker.

### Power Management

The TR83100 is intended to be used in battery operated applications where power management is critical. The TR83100 uses an intelligent power management scheme. The TR83100 conserves power by shutting down the AFE during playback and the ABE during a record operation.

The TR83100 enters a power down state whenever it finds that keys have not been pressed in the last 3 seconds. In the power down state all device activities are stopped, including the clock. The TR83100 uses switch activity to trigger its exit from the power down state. A falling edge on any of the command input lines (PLAY, RECORD, DELETE, etc.) will cause it to exit the power down state. The TR83100 will then execute the command. Thus, the power down state is completely transparent to the user.

### Voice Data Storage

Flash memory devices offer the advantage of power saving, are non-volatile and less expensive than DRAM. The TR83100 supports parallel Flash memory such as the Atmel, Samsung and SST devices. The system is designed to work with either one or two flash memory devices. If more than one flash memory is used in the system, it has to be of the same kind. When a single flash memory is used, it should be connected to CS0.

### Parallel Flash Memory

Presently the parallel flash memory devices from Atmel, Samsung and SST are supported. The TR83100 controller takes complete responsibility for interfacing to the parallel flash memory. The TR83100 selects the Flash read/write algorithm depending upon the Flash memory selected through pins FSEL1 and FSEL2, which may be tied to VSS or VDD.

Table 1. Memory Selection

Flash Memory	FSEL1	FSEL2
SST 28SF040	0	0
SST 29EE010	0	1
SAMSUNG KM29N040T	1	0
ATMEL AT29C040 /AT29C040A / AT29C020/AT29C010	1	1

After detection of memory, the system will look for a three byte signature in the storage memory. If signature does not match correctly, the system will automatically execute an ERASEALL operation and the signature will be written to the memory.

For Samsung flash memory (KM29N040) the system is able to scan the memory for detecting bad sectors when the system is powered for the first time. This scanning process can take upto one minute. During scanning LED2 remains ON. On completion of scanning, LED2 will be OFF. The bad sector information is saved in memory, and the system uses this information on all subsequent power on resets.

**Compression Schemes**

The system supports two kinds of compression schemes: 10 Kbps and 20 Kbps. Both are based on ADPCM algorithm. The QUALSW input is used to select the compression scheme during recording.

**Table 2.** Compression Scheme Selection

QUALSW	Compression Scheme
HIGH	20 Kbps
LOW	10 Kbps

Compression quality can be selected dynamically on a per message basis.

During playback, the code will automatically select the decompression scheme depending on the selection made during recording of the message.

The TR83100 can support pre-stored voice prompts, ROM speech storage and serial communication with a microcontroller if internal ROM code is customized. TR83100 uses a popular 8 bit microcontroller core. Please contact TriTech for details.

**External Component Connections**

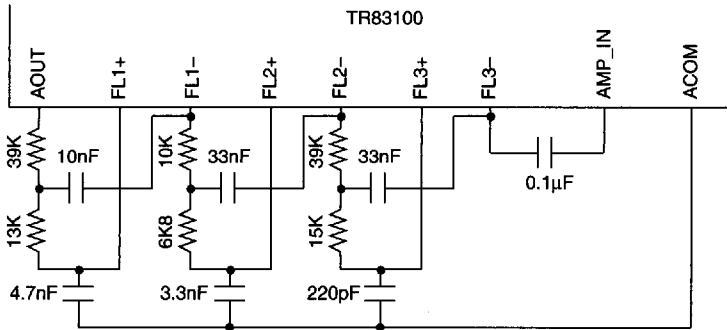

**Figure 4 • Active Filter Connections**

**Note:**

These are suggested values only. Please refer to Application Note for filter design.

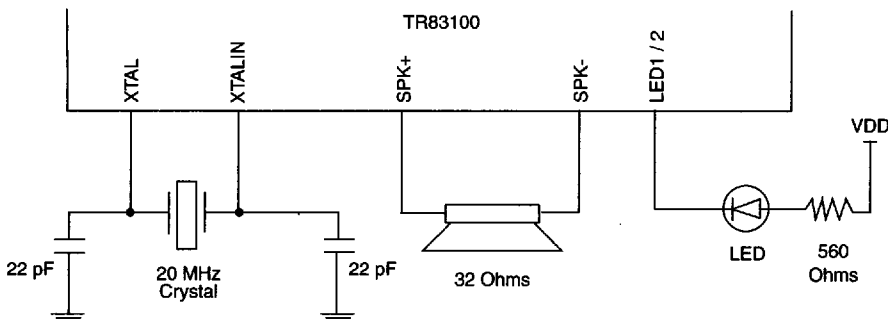

**Figure 5 • Crystal, Speaker & LED connections**

## SPECIFICATIONS

## Absolute Maximum Ratings

Symbol	Parameter	Min	Max	Units
V	Supply Voltage	-0.5	6.5	V
V <sub>i</sub>	Input Voltage	-0.5	VDD + 0.5	V
V <sub>o</sub>	Output Voltage	-0.5	VDD + 0.5	V
T <sub>s</sub>	Storage Temperature	-40	125	°C

## Recommended DC Operating Conditions

Symbol	Parameter	Min	Typ	Max	Units
VDD	Supply Voltage	4.5	5	5.5	V
AVD	Supply Voltage	4.75	5	5.25	V
T <sub>a</sub>	Ambient Temperature	0		70	°C

## General Specifications (@VDD = 5.0V)

Symbol	Parameter	Condition	Min	Typ	Max	Units
I <sub>il</sub>	Low Level Input Current	V <sub>in</sub> =V <sub>ss</sub>	-10		+10	μA
I <sub>ih</sub>	High Level Input Current	V <sub>in</sub> =V <sub>dd</sub>	-10		+10	μA
I <sub>oz</sub>	Tristate Output Leakage Current	V <sub>out</sub> =0/V <sub>dd</sub>	-10		+10	μA
V <sub>-</sub>	Schmitt Negative Threshold	TTL-static CMOS-static	0.8 1.5		1.3 2.5	V
V <sub>+</sub>	Schmitt Positive Threshold	TTL-static CMOS-static	1.4 2.5		2.1 3.5	V
V <sub>h</sub>	Schmitt Hysteresis	TTL-static CMOS-static		0.6 1.0		V
V <sub>il</sub>	Low Level Input Voltage	TTL-static			0.8	V
V <sub>ih</sub>	High Level Input Voltage	TTL-static	2.0			V
V <sub>ol</sub>	Low Level Output Voltage	TTL-static			0.4	V
V <sub>oh</sub>	High Level Output Voltage	TTL-static	2.4			V
R <sub>pd</sub>	Pull-down resistance	V <sub>in</sub> =V <sub>dd</sub>	50		200	kΩ
R <sub>pu</sub>	Pull-up resistance	V <sub>in</sub> =V <sub>ss</sub>	50		200	kΩ
C <sub>in</sub>	Input Capacitance	Freq=1MHz@0V			5	pF
C <sub>out</sub>	Output Capacitance	Freq=1MHz@0V			5	pF
C <sub>i/o</sub>	Bi-directional Capacitance	Freq=1MHz@0V			5	pF
I <sub>ccp</sub>	Supply current (play)	(32Ω speaker)		77		mA
I <sub>ccr</sub>	Supply current (record)				33	mA
I <sub>ccpd</sub>	Supply current (power down)	(Digital Inputs high)			10	μA
PD <sub>max</sub>	Maximum power dissipation	@5V		380		mW

**AGC Specifications**

Symbol	Parameter	Min	Typ	Max	Units
MICin	Microphone Input Range	30		200	mVpp
AGC <sub>ol</sub>	AGC Output Level	2.1	2.2	2.3	Vpp
AGC <sub>gain</sub>	AGC Fixed gain		20		dB
THD <sub>agc</sub>	THD @ 1kHz		1	2	%
N <sub>agc</sub>	Noise at silence input			-60	dB
T <sub>at</sub>	Attack Time		100		ms
T <sub>rl</sub>	Release Time		1		s

**Recommended values of external components for Analog Front End**

Name	Pin No.	Remarks
AGC_CTL	58	Connect 100 K $\Omega$ resistor and a 10uF Electrolytic Cap. to AVSS.
ADC_CAP	56	Connect a 0.1 $\mu$ F Ceramic Cap. to AVSS (minimum).
AGC_CAP	59	Connect a 10 $\mu$ F Electrolytic Cap. to AVSS.
REF_CAP	55	Connect a 10 $\mu$ F Electrolytic Cap. to AVSS.

**Power Amplifier Specifications**

Symbol	Parameter	Min	Typ	Max	Units
A <sub>pa</sub>	Gain		6		dB
THD <sub>pa</sub>	THD @ 1kHz			1	%
Z <sub>out</sub>	Output Load		32		$\Omega$
P <sub>rms</sub>	RMS Power, with 32 $\Omega$ speaker‡			62.5	mW

 ‡ 4 volts pk-to-pk across 32 $\Omega$  speaker

MECHANICAL DIMENSIONS

80-pin Plastic Quad Flat Pack (PQFP)

Dimension in inches (mm)

