

Kabelzuschnitt
Stripping dimension
TZC 75024

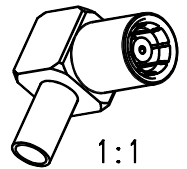
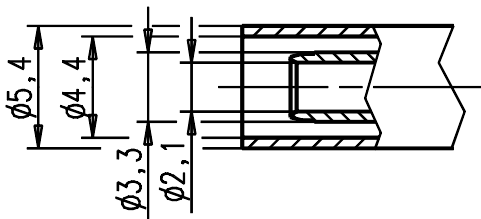
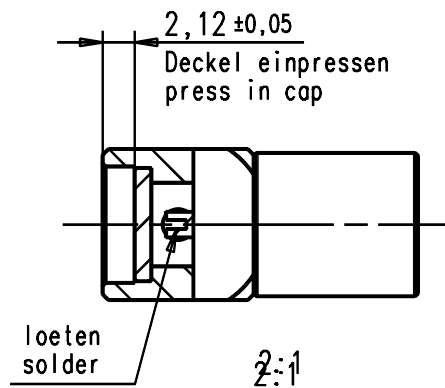
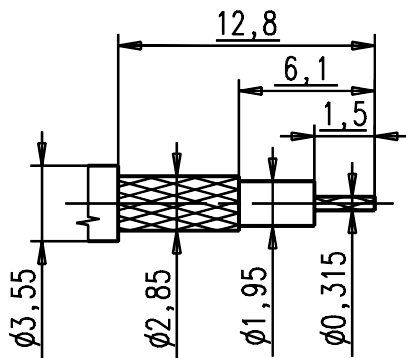

Nur fuer Kabel: **TZC 75024**
Only for cable:

Aussenkontakt/ outer contact: Crimp SW/AF 4,52 / L= 10
Innenkontakt/ inner contact : solder

				general tolerance ISO 2768 mH		scale: 3:1	
						Assembly instruction: M-18 Stripping dimension:	
				generate	14.05.02	name	Kabelwinkelbuchse Cable mount angle jack
				checked			
				Norm			
				38758			
design	a	el. optimiert	20.06.02	Mayer			3495.11.2420.03'
nr.	rev.	alteration	date	name			

75Ω