



T-51-07-01

μA9708 6-Channel 8-Bit μP Compatible A/D Converter

General Description

The μA9708 is a single slope 8-bit, 6-channel ADC subsystem that provides all of the necessary analog functions for a microprocessor-based data control system. The device uses an external microprocessor system to provide the necessary addressing, timing and counting functions and includes a 1-of-8 decoder, 8-channel analog multiplexer, sample and hold, ramp integrator, precision ramp reference, and a comparator on a single monolithic chip.

Features

- MPU compatible
- Excellent linearity over full temperature range ±0.2% maximum
- Typical 300 μs conversion time per channel
- Wide dynamic range includes ground
- Auto-zero and full-scale correction capability
- Ratiometric conversion—no precision reference required
- Single-supply operation
- TTL compatible
- Does not require access to data bus or address bus

Connection Diagram

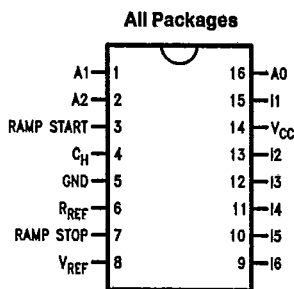

TL/H/10409-2

Order Number μA9708DC or μA9708DM
See NS Package Number J16A

Order Number μA9708PC
See NS Package Number N16E

Block Diagram

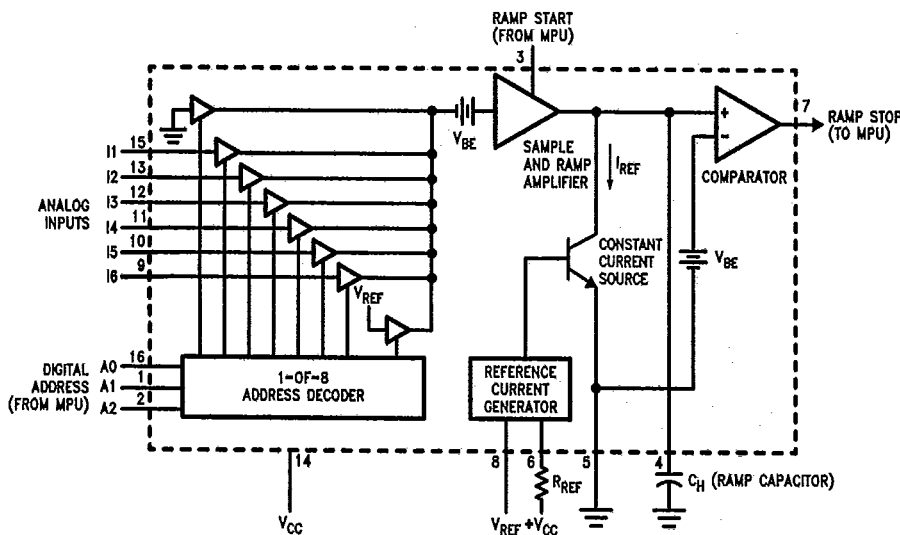

TL/H/10409-1



Absolute Maximum Ratings (Note 1)

If Military/Aerospace specified devices are required, please contact the National Semiconductor Sales Office/Distributors for availability and specifications.

Supply Voltage (V_{CC})	18V
Comparator Output (Ramp Stop)	-0.3V to +18V
Analog Input Range	-0.3V to +30V
Digital Input Range	-0.3V to +30V
Output Sink Current	10 mA
Storage Temperature Range	-65°C to +150°C
Continuous Total Dissipation	
Ceramic DIP Package	900 mW
Molded DIP Package	1000 mW

Pin Temperature	
Ceramic DIP (Soldering, 60 Sec.)	300°C
Molded DIP (Soldering, 10 Sec.)	260°C

Operating Ratings (Note 1)

Operating Temperature Range	
μA9708PC, μA9708DC	0°C to +70°C
μA9708DM	-55°C to +125°C
Supply Voltage (V_{CC})	4.75V to 15V
Reference Voltage (V_{REF}) (Note 2)	2.8V to 5.25V
Ramp Capacitor (C_H)	300 pF
Reference Current (I_R)	12 μA to 50 μA
Analog Input Range	0V to V_{REF}
Ramp Stop Output Current	1.6 mA

Electrical Characteristics

Over recommended operating conditions, $V_{CC} = 5.0V$, $-55^\circ C \leq T_A \leq +125^\circ C$ for μA9708DM and $0^\circ C \leq T_A \leq +70^\circ C$ for μA9708DC or μA9708PC; unless otherwise specified.

Symbol	Parameter	Conditions	Min	Typ	Max	Units
E_A	Conversion Accuracy	Over Entire Temperature Range (Note 3)		±0.2	±0.3	%
E_R	Linearity	Applies to Any One Channel (Note 4)		±0.08	±0.2	%
V_{OSM}	Multiplexer Input Offset Voltage	Channel ON		2.0	4.0	mV
t_C	Conversion Time per Channel	Analog Input = 0V to V_{REF} $C_H = 300$ pF, $I_{REF} = 50$ μA		296	350	μs
t_A	Acquisition Time	$C_H = 1000$ pF		20	40	μs
I_A	Acquisition Current		150			μA
t_O	Ramp Start Delay Time			100		ns
t_M	Multiplexer Address Time			1.0		μs
V_{IH}	Digital Input HIGH Voltage	A0, A1, A2, Ramp Start	2.0			V
V_{IL}	Digital Input LOW Voltage	A0, A1, A2, Ramp Start			0.8	V
I_B	Analog Input Current	Channel ON or OFF	-3.0	-1.0		μA
I_{IL}	Input LOW Current	A0, A1, A2, Ramp Start = 0.4V	-15	-5		μA
I_{IH}	Input HIGH Current	A0, A1, A2, Ramp Start = 5.5V			1.0	μA
I_{OS}	Input Offset Current			1.0	3.0	μA
I_{OH}	Comparator Logic "1" Output Leakage Current	$V_{OH} = 15V$			10	μA
V_{OL}	Comparator Logic "0" Output Voltage	$I_{OL} = 1.6$ mA			0.4	V
PSRR	Power Supply Rejection Ratio	(Note 5)	40			dB
	Cross Talk between Any Two Channels	(Note 6)	60			dB
I_{CC}	Power Supply Current	$V_{CC} = 5V$ to 15V, $I_O = 0$		7.5	15	mA
C_{IN}	Input Capacitance			3.0		pF
C_{OUT}	Comparator Output Capacitance			5.0		pF

Note 1: Absolute Maximum Ratings indicate limits beyond which damage to the device may occur. Operating Ratings indicate conditions for which the device is intended to be functional, but do not guarantee specific performance limits.

Note 2: V_{REF} should not exceed $V_{CC} - 2V$.

Note 3: Conversion accuracy is defined as the deviations from a straight line drawn between the points defined by channel address 000 (0 scale) and channel address 111 (full scale) for all channels.

Note 4: Linearity is defined as the deviation from a straight line drawn between the 0 and full scale points for each channel.

Note 5: Power supply rejection ratio is defined as the conversion error contributed by power supply voltage variations while resolving mid scale on any channel.

Note 6: Cross Talk between channels = $20 \log \frac{\Delta V_{CH}}{\Delta V_I}$

T-51-07-01

μA9708

Timing Diagram and Test Circuits

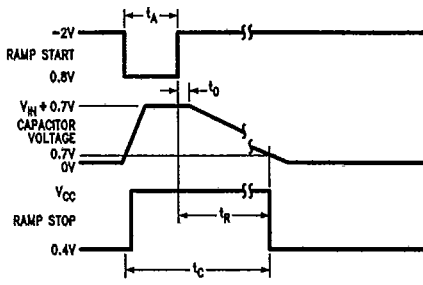

TL/H/10409-7

FIGURE 1. Equivalent Timing Waveform for Test Circuits and Applications

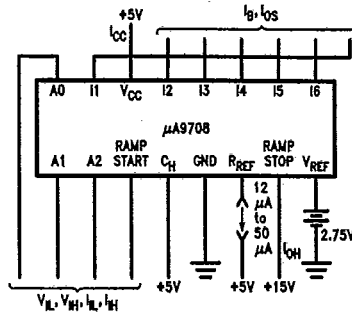

TL/H/10409-10

FIGURE 4. Static Measurements

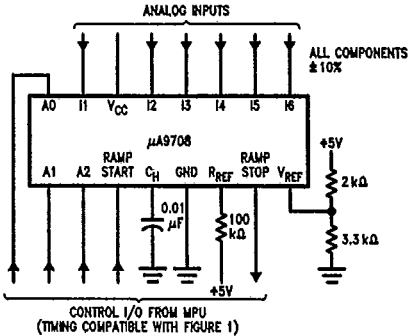

TL/H/10409-8

Input Timing:

$t_A > 400 \mu s$

$$V_{REF} = \left(\frac{3.3 \text{ k}\Omega}{2 \text{ k}\Omega + 3.3 \text{ k}\Omega} \right) 5V = 3.1$$

$$I_R = \frac{5 - 3.1}{100 \text{ k}\Omega} = 19 \mu A$$

$$t_{R|_{max}} = \text{full scale ramp time} \\ = \frac{0.01 \times 10^{-6}}{19 \times 10^{-6}} \times 3.1 = 1.6 \text{ ms}$$

Note: For evaluation purposes, the ramp start timing generation can be implemented with an LM555 timer (astable operation) or MPU evaluation kit, and a time interval meter for ramp time measurement. The TIM meter will measure the time between 0 to 1 transition of the ramp start and the 1 to 0 transition of the ramp stop. The ramp stop is open collector, and must have an external pull-up resistor to V_{CC}.

FIGURE 2. Slow Speed Evaluation Circuit for Ratimetric Operation

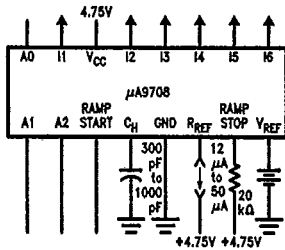

TL/H/10409-9

FIGURE 3. Linearity/Acquisition Time/Conversion Time Test Circuit

Functional Description

This Analog to Digital Converter is a single-slope 8-bit, 6-channel A/D converter that provides all of the necessary analog functions for a microprocessor-based data/control system. The device uses the processor system to provide the necessary addressing, timing and counting functions and includes a 1-of-8 decoder, 8-channel analog multiplexer, sample and hold, precision current reference, ramp integrator and comparator on a single monolithic chip.

Applications that require auto-zero or auto-calibration, (See Figures 5-8) can use selection of address 000 and 111, for input address lines A0-A2, in conjunction with the arithmetic capability of a microprocessor to provide ground and scaling factors. Address 0, 0, 0 internally connects the input of the ramp generator to ground and may be used for zero offset correction in subsequent conversions. Address 1, 1, 1, internally connects the input of the ramp generator to the voltage reference, V_{REF}, and may be used for scale factor correction in subsequent conversions. For the following, refer to the Functional Block Diagram.

Six separate external analog voltage inputs may come into terminals 11-16 and the specific analog input to be converted is selected via address terminals A0-A2. The analog input voltage level is transferred to the external ramp capacitor connected to pin 4 when the input to the ramp start terminal (pin 3) is at a logic 0 (See Figure 1). The time to charge the capacitor is the acquisition time which is a function of the output impedance of an amplifier internal to the A/D converter and the value of the capacitor. After charging the external capacitor the ramp start terminal is switched to a logic 1 which introduces a high impedance between the analog input voltage and the external capacitor.

The capacitor begins to discharge at a controlled rate. The controlled rate of discharge (ramp) is established by the external reference voltage, the external reference resistor, the value of the external capacitor and the internal leakage of the A/D converter. Connected to the capacitor terminal is a

3

μA9708

T-51-07-01

Functional Description (Continued)

Auto-Zero and Full-Scale Features

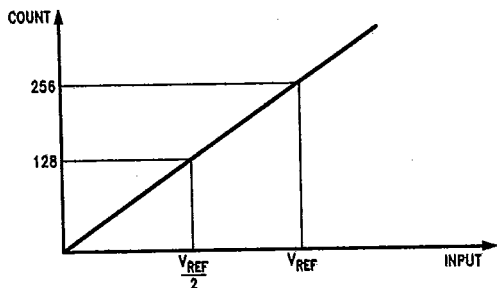

TL/H/10409-3

No Zero Offset
No Full-Scale Error

$$\text{Count } (n) = \frac{V_{IN}}{V_{REF}} \times 256$$

FIGURE 5. Ideal Transfer Function

comparator internal to the A/D converter with its output going to the ramp stop terminal (pin 7). The comparator output is a logic one when the capacitor is charged and switches to a logic 0 when the capacitor is in a discharged state. The ramp time is from the time when ramp start goes HIGH (logic "1") to when ramp stop goes LOW (logic "0"). The microprocessor must be programmed to determine this conversion time. The ideal (no undesirable internal source impedances, leakage paths, errors on levels where comparator switches or delay time) conversion time is calculated as follows:

$$\text{Ramp Time} = V1 \frac{C_H}{I_R}$$

Where $V1$ = Analog Input Voltage Being Measured
 C_H = External Ramp Capacitor
 $I_R = \frac{V_{CC} - V_{REF}}{R_{REF}}$

Where V_{CC} = Power Supply Voltage
 V_{REF} = Reference Voltage
 R_{REF} = Reference Resistor

In actual use the errors due to a nonideal A/D converter can be minimized by using a microprocessor to make the calculations. (See Figures 5 through 8.)

Channel Selection

Input Address Line			Selected Analog Input
A2	A1	A0	
0	0	0	Ground
0	0	1	I1
0	1	0	I2
0	1	1	I3
1	0	0	I4
1	0	1	I5
1	1	0	I6
1	1	1	V_{REF}

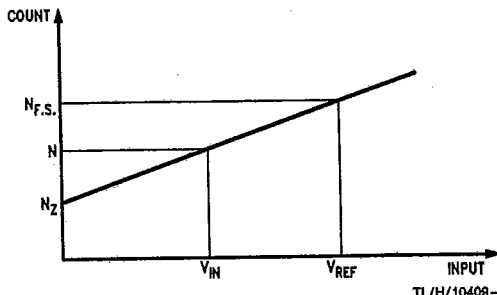

TL/H/10409-4

$N_{F.S.} \neq 256$
 $N_Z \neq 0$
(N) has both full-scale and zero errors

FIGURE 6. Transfer Function with Zero and Full-Scale Error

Auto-Zero and Full-Scale Features (Continued)

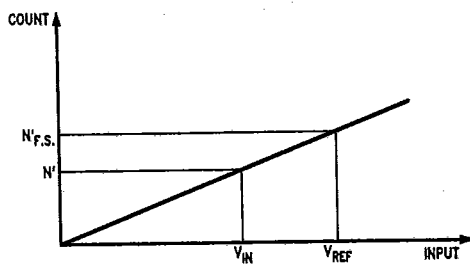

TL/H/10409-5

$N' = N - N_Z$
 N' has Full-Scale Error

FIGURE 7. Transfer Functions with Zero-Correction Added

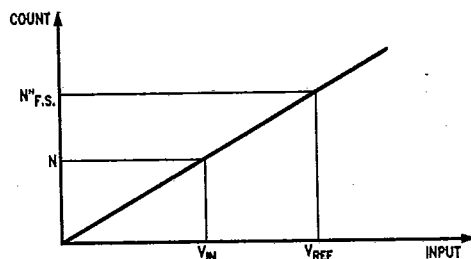

TL/H/10409-6

$$N^* = (N - N_Z) \times \frac{256}{(N_{F.S.} - N_Z)}$$

FIGURE 8. Transfer Function with both Zero and Full-Scale Correction Added

Typical Applications

T-51-07-01

Application Suggestions and Formulas

1. The capacitor node impedance is approximately 30 μΩ and should have no parallel resistance for proper operation.
2. t_R when V_{IN} = 0V will be finite (i.e., the comparator will always toggle for V_{IN} ≥ 0V).
3. The ramp stop output is open collector, and an external pull-up resistor is required.
4. All digital inputs and outputs are TTL compatible.
5. For proper operation, timing commences on the 0 to 1 transition of ramp start and terminates on the 1 to 0 transition of ramp stop.
6. $t_A \geq \frac{C_H}{150 \mu A - I_R} \times V_{REF}$ (See Figure 1)
7. t_R (ramp time) = $\frac{C_H}{I_R \times V_{IN}}$, $t_{R|max} = \frac{C_H}{I_R} \times V_{REF}$ (See Figure 1)
8. $I_R = \frac{V_{CC} - V_{REF}}{R_{REF}}$
9. $2V \leq V_{REF} \leq (V_{CC} - 2V)$
10. Address lines A0, A1, A2 must be stable throughout the sampling interval, t_A.
11. Pin 6 (R_{REF}) should be bypassed to ground via a 0.02 μF capacitor.

Microprocessor Considerations

Several alternatives exist from a hardware/software standpoint in microprocessor based systems using the μA9708.

- .. The ramp time measurement may be implemented in software using a register increment, followed by a branch back depending on the status of the ramp stop.
 - 2. Alternately, the ramp stop may be tied into the interrupt structure in systems containing a programmable binary timer. This scheme has the following advantages:
 - a. The CPU is not committed during the ramp time interval.
 - b. It requires only 4 bits of an I/O port for control signals.
 - 3. The auto-zero/auto-full-scale (See Figures 5-8) should use double precision, rounded (as opposed to truncated) arithmetics. Several points are worth noting:
 - a. The subtractions are single op code instructions.
 - b. The full scale correction uses a multiply by 256 and can be accomplished by a shift left 8 bits (usually one instruction) or placing (N - N_Z) in the MSB register and setting the LSB register to zero, for the double precision divide.
 - c. The divisor (N_{F.S.} - N_Z) of the MSB register will always be zero.
- These schemes have the following advantages:
- a. No access to the data bus or address bus is required, by the A/D system.
 - b. 4 I/O bits completely support the A/D system.
 - c. Since auto full scale/auto zero are implemented in software and long term drift (aging) effects are eliminated.
 - d. Software overhead is minimal (typically 30 bytes).
 - e. Where ratiometric operation is permissible, the 4 external components may be ±5% tolerance, including the power supply.

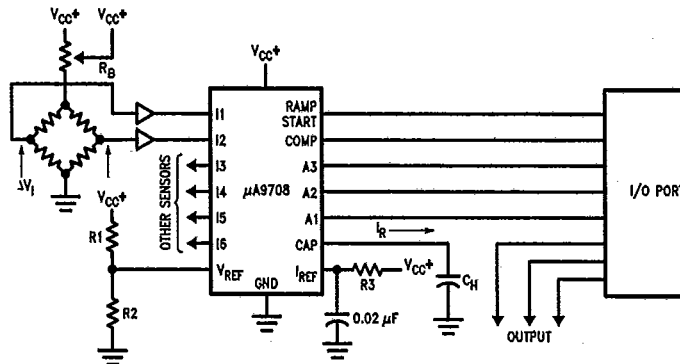

Note: ΔV_I = (Applied Force) and can be Linearized (if necessary) in Software.

TL/H/10409-11

FIGURE 9. Ratiometric Strain Gage Sensor/Controller

3

μA9708

T-51-07-01

Typical Applications (Continued)

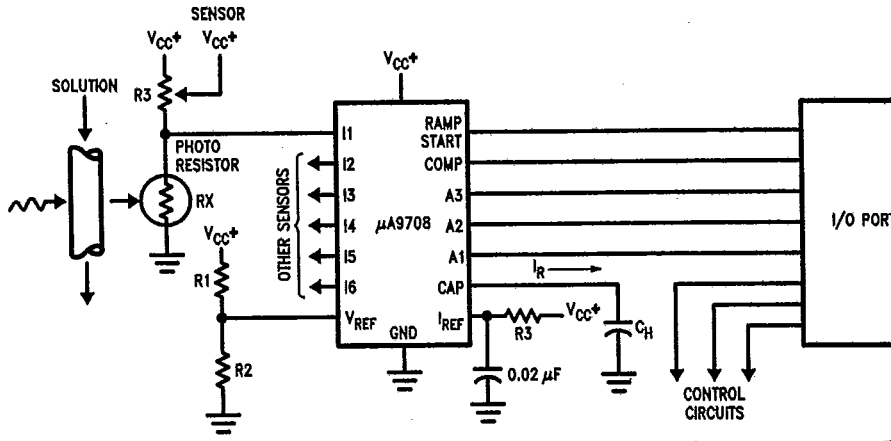

TL/H/10409-12

Applications
 Beverage Brewers/Dispensers
 Chemical Solution Control
 Automatic Liquid Mixing Control

$$\text{Ramp Current} = I_R = V_{CC} \left(\frac{R_1}{R_1 + R_2} \right) \left(\frac{1}{R_3} \right)$$

$$V_1 = \left(\frac{R_X}{R_X + R_B} \right) V_{CC}$$

$$\text{Ramp Time} = V_1 \left(\frac{C_H}{I_R} \right) = \left(\frac{R_X}{R_X + R_B} \right) \left(1 + \frac{R_2}{R_1} \right) (C_H R_3)$$

FIGURE 10