

High Current Connector

PS2 Series



■ Features

1. Power/Signal Hybrid Connector

The Hybrid design saves space by combining power

and signal contacts together in one unit with dedicated power contacts to handle 100, 200 or 300 Amps.

2. Floating Structure

The structure allows up to ± 2.5 mm of float in the X and Y directions, which makes mating easier even when the mating position is not clearly visible.

3. Sequential Contact System

This series utilizes sequential contacts, the power contacts mate before the signal contacts. This prevents incomplete mating and also prevents hot swapping.

4. Finger Protection Structure

For added safety, the plug side (battery side) is designed to prevent shock hazard and provides for more user safety and security.

5. Plug-in Design

Its unique plug-in design provides enhanced safety features, reduced production costs related to its installation and the maintenance of high current units.

(Installation)

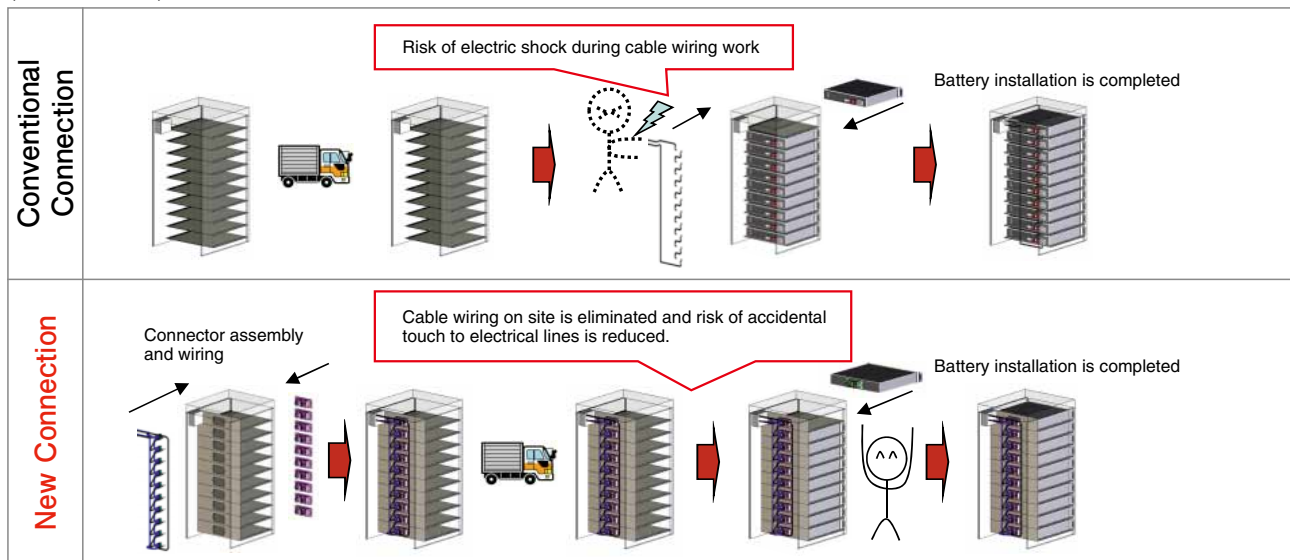

(Maintenance)

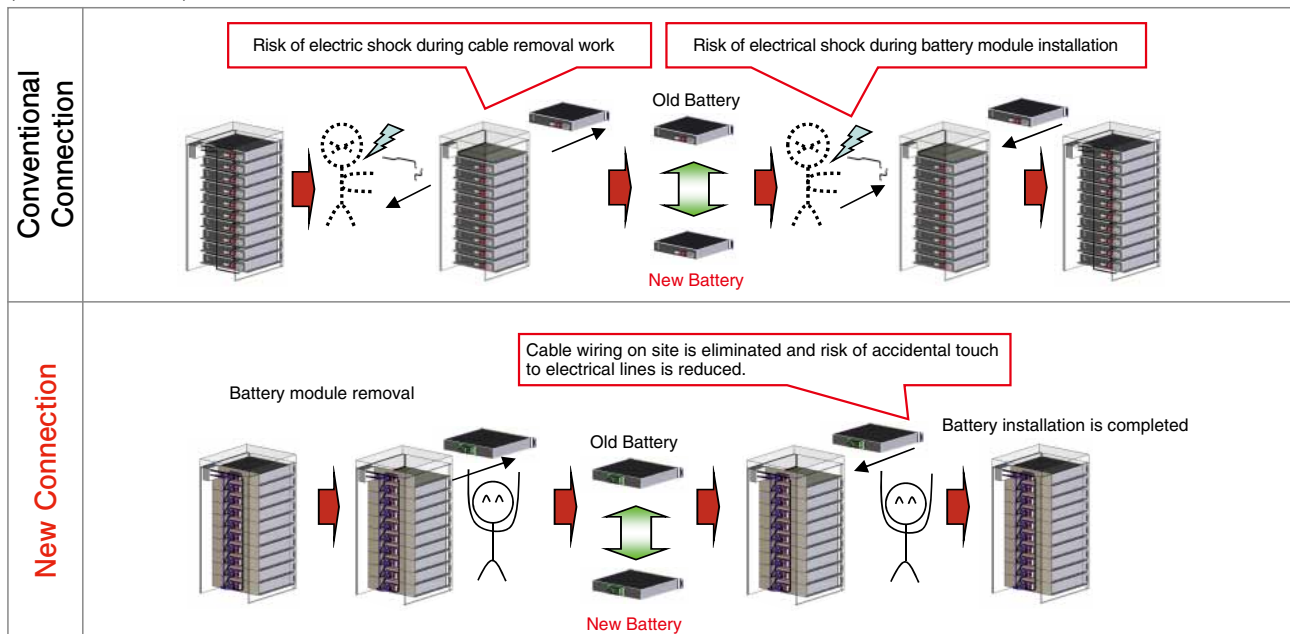

Applications

Storage Battery, UPS

Usage example

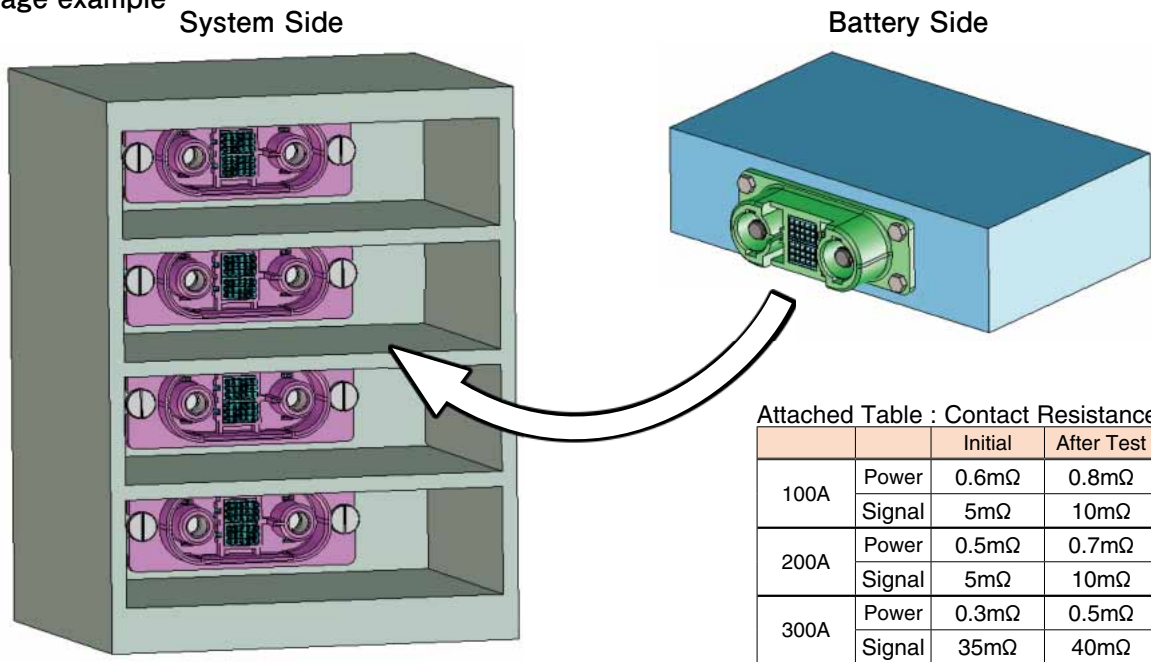

Attached Table : Contact Resistance

		Initial	After Test
100A	Power	0.6mΩ	0.8mΩ
	Signal	5mΩ	10mΩ
200A	Power	0.5mΩ	0.7mΩ
	Signal	5mΩ	10mΩ
300A	Power	0.3mΩ	0.5mΩ
	Signal	35mΩ	40mΩ

Product Specifications

Ratings	—	Power Part	Derating curve, ambient temp 25°C	Applicable cables	Signal Part	Operating Temp. Range
	Current	300A	—	150sq, 300MCM	5A	-40~105°C
		200A	330A	180sq, AWG#3/0		Storage Temp. Range
100A	175A	38sq, AWG#2	-55~60°C			
Voltage	1,000V			100V		

Item	Specifications	Conditions
1. Contact resistance	Attached table	Measured at DC 1 A Measured at DC 100 mA
2. Insulation resistance	5,000 MΩ or more	Measured at DC 250 V
3. Withstand voltage	No flashover or breakdown	Power: Apply AC 2,000 V for one minute Signal: Apply AC 1,000 V for one minute
4. Durability	Attached table	50 mating cycles
5. Shock resistance	No electrical discontinuity of 10 μs or more	Acceleration 490 m/s ² , duration 11 ms, half-sine wave, 3 times each for each of the 3 axes.
6. Vibration resistance	No electrical discontinuity of 10 μs or more	10 cycles in each of 3 axial directions at frequency 10-55 Hz, half amplitude 0.75 mm
7. Temperature cycles	Attached table Minimum of 1,000 MΩ	Temperature: -40 → 105°C Time: 30 → 30 min
8. Salt water spray	No significant corrosion	5% salt water spray concentration while keeping samples at 35°C for 48 hours.

Materials / Finish

Receptacle

Parts	Materials	Color/Finish	Remarks
Insulation case	Synthetic resin	Black	UL94V-0
Power contact	Brass/Copper alloy	Silver plated	—
Contact spring	Copper alloy	Silver plated	—
Rotation stopper	Synthetic resin	Black	UL94V-0
Crimp case	Synthetic resin	Black	UL94V-0
Signal contact	Copper alloy	Gold plated	—
Floating screw	Stainless steel/Steel	—/Trivalent chrome	—

Plug

Parts	Materials	Color/Finish	Remarks
Insulation case	Synthetic resin	Black	UL94V-0
Power contact	Brass/Copper alloy	Silver plated	—
Rotation stopper	Synthetic resin	Black	UL94V-0
Cap	Synthetic resin	Black	UL94V-0
Crimp case	Synthetic resin	Black	UL94V-0
Signal contact	Copper alloy	Gold plated	—

Product Number Structure

Refer to the chart below when determining the product specifications from the product number.
Please select from the product numbers listed in this catalog when placing orders.

Connector

PS2 – **2** **W** **P** / **6C** / **6C**

① ② ③ ④ ⑤ ⑥

Crimp Case

PS2 – **6** **PC**

① ⑦ ⑧

Crimp Contact

PS2 – **1618** **P** **C** **F** **A**

① ⑨ ④ ⑩ ⑪ ⑫

①	Series name
②	No. of power contacts
③	R : 100A V : 200A W : 300A
④	P : Male S : Female
⑤	Signal contact block 1
⑥	Signal contact block 2
⑦	No. of signal contacts
⑧	PC : Male crimp case SC : Female crimp case
⑨	Applicable wires of signal contact 16-18 AWG
⑩	Crimp contact
⑪	F : Reel contacts None: Loose piece contacts
⑫	Gold plating

Functional Diagram

100A type

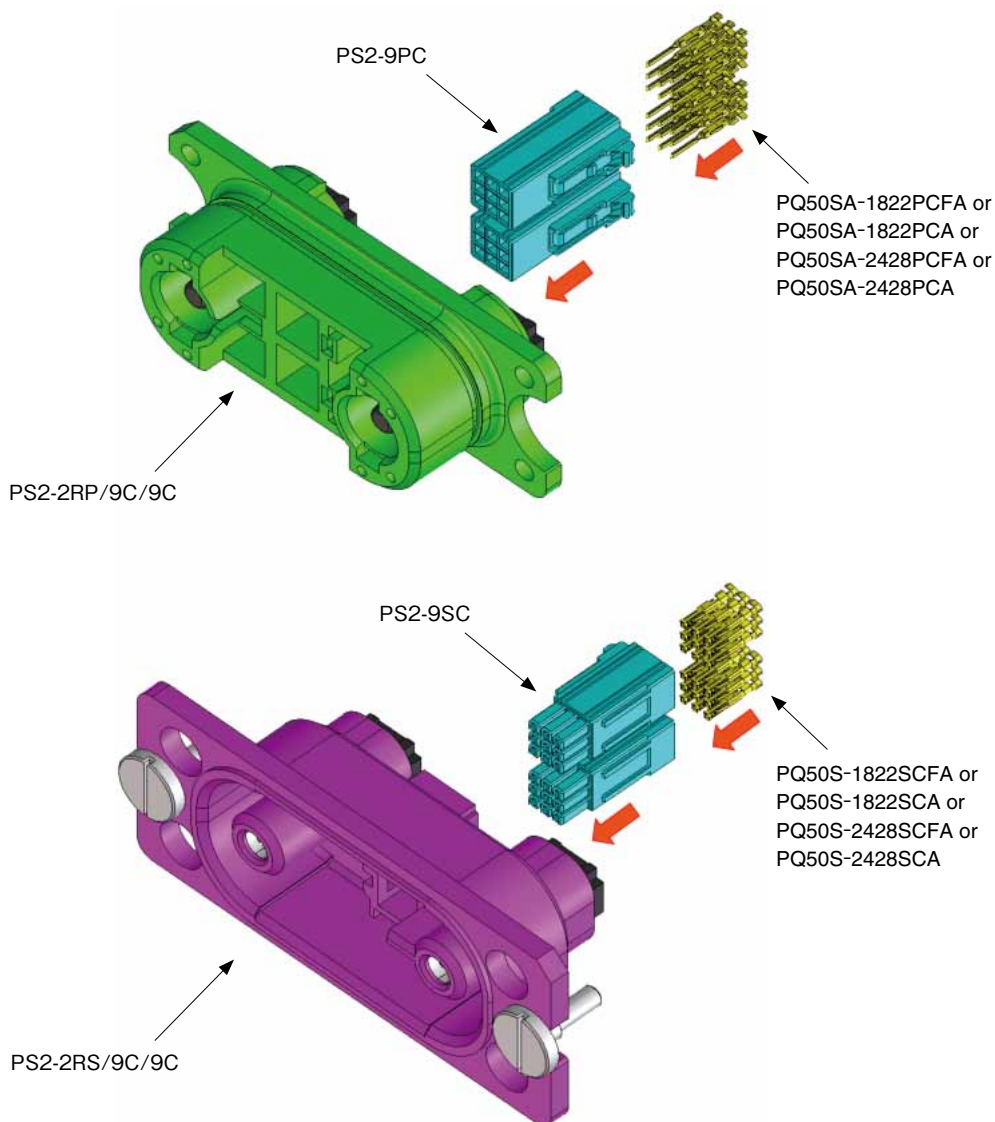

●200A type

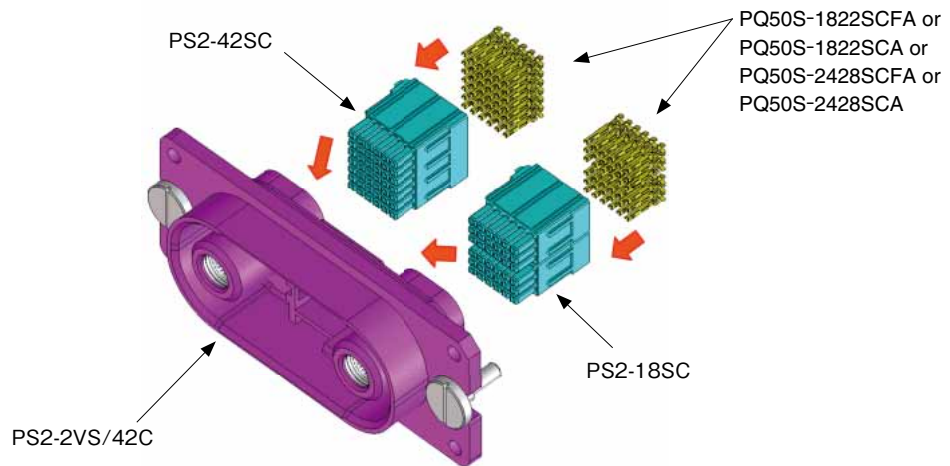
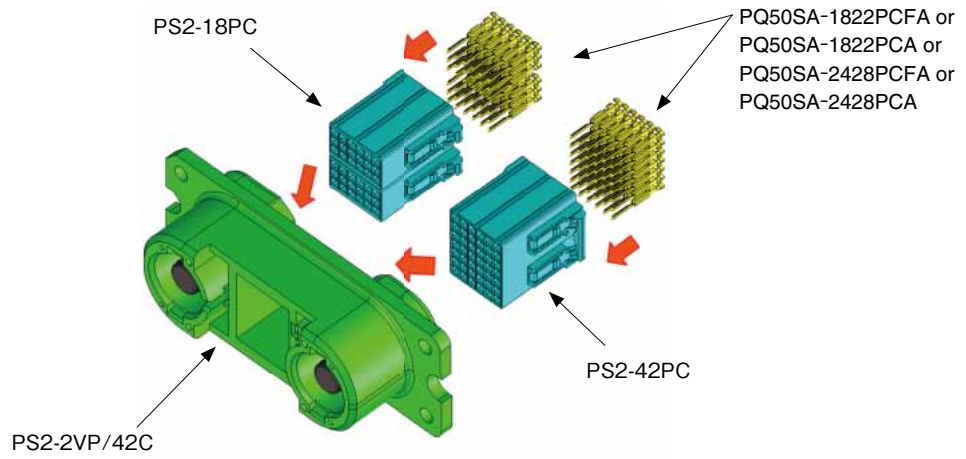

●300A type

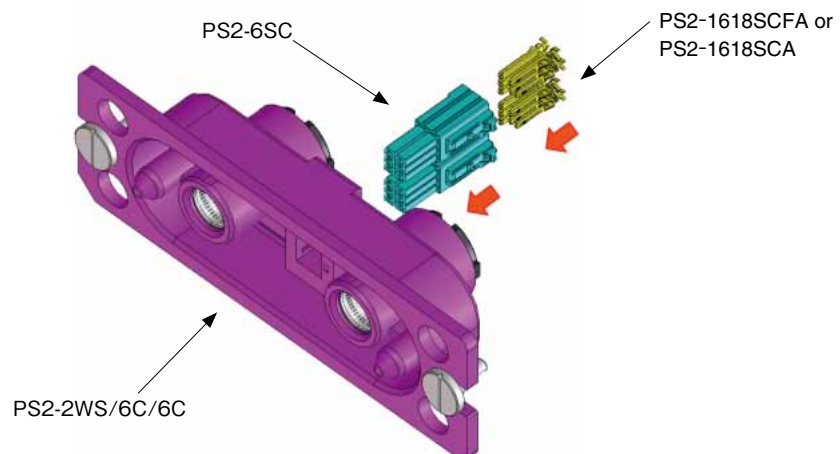
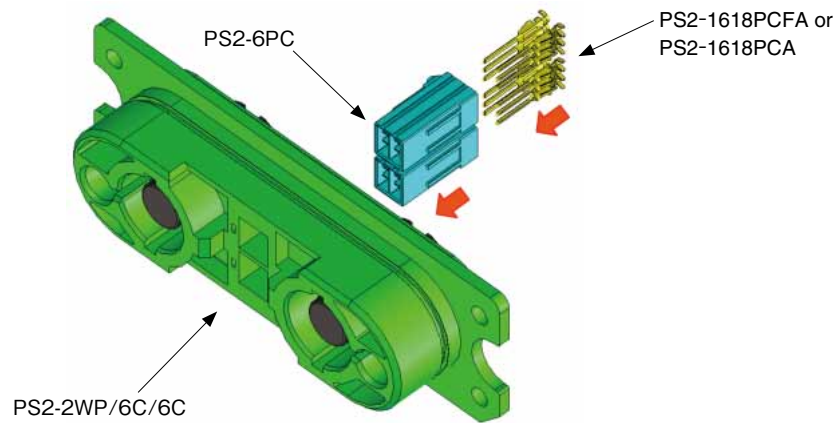

Plug

Current	Part No.	HRS No.	Sales Unit	RoHS
100A	PS2-2RP/9C/9C	236-1036-0 00	Each	○
200A	PS2-2VP/42C	236-1060-4 00		○
300A	PS2-2WP/6C/6C	236-1032-9 00		○

◇100A

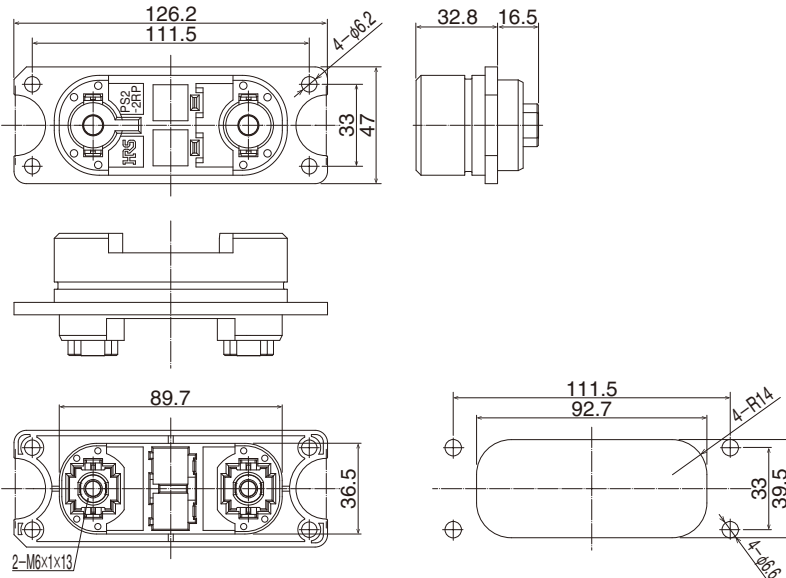

◇200A

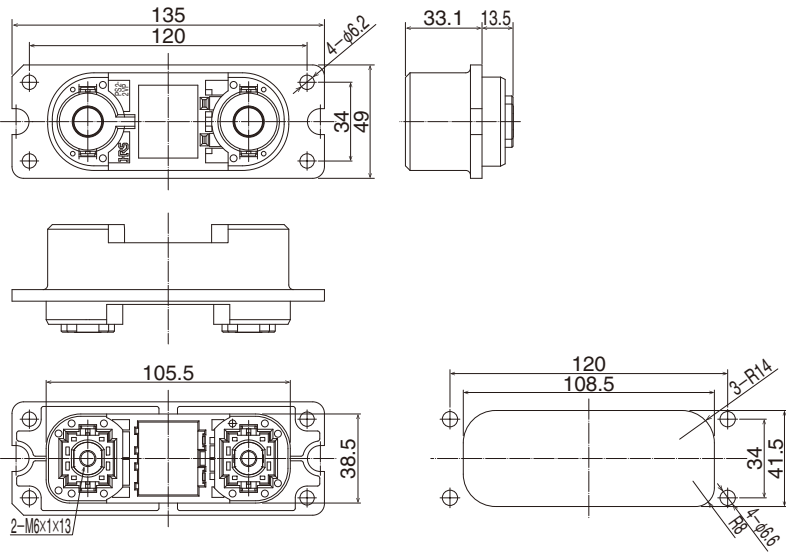

◇300A

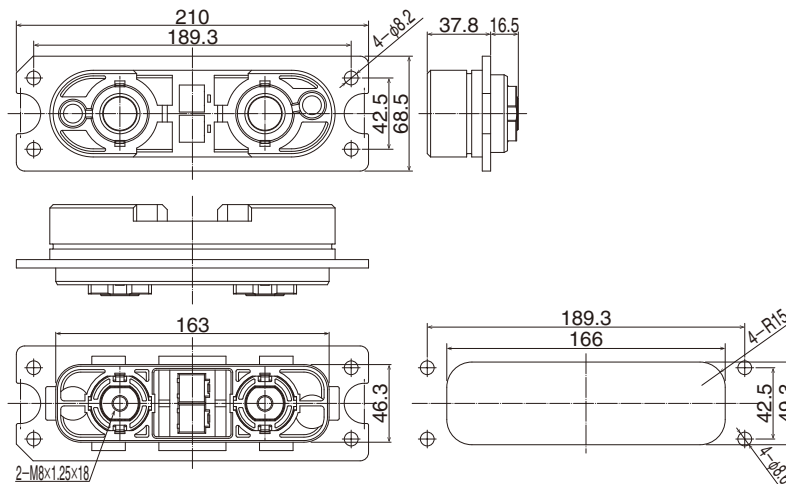

Oct. 1. 2022 Copyright 2022 HIROSE ELECTRIC CO., LTD. All Rights Reserved.

Receptacle

Current	Part No.	HRS No.	Sales Unit	RoHS
100A	PS2-2RS/9C/9C	236-1037-2 00	Each	○
200A	PS2-2VS/42C	236-1046-3 00		○
300A	PS2-2WS/6C/6C	236-1033-1 00		○

◇100A

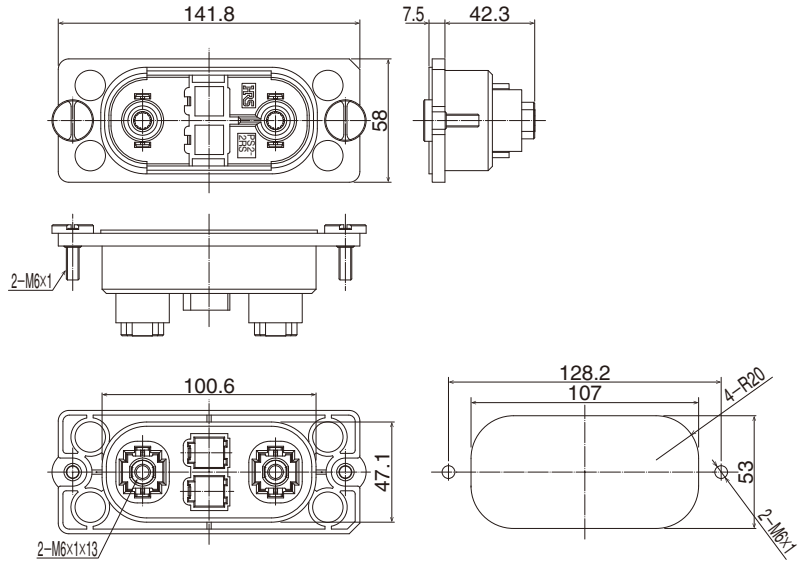

◇200A

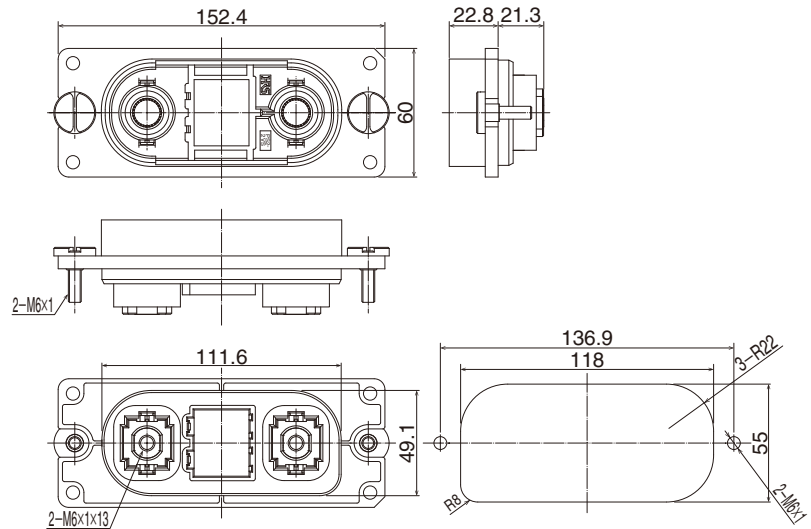

◇300A

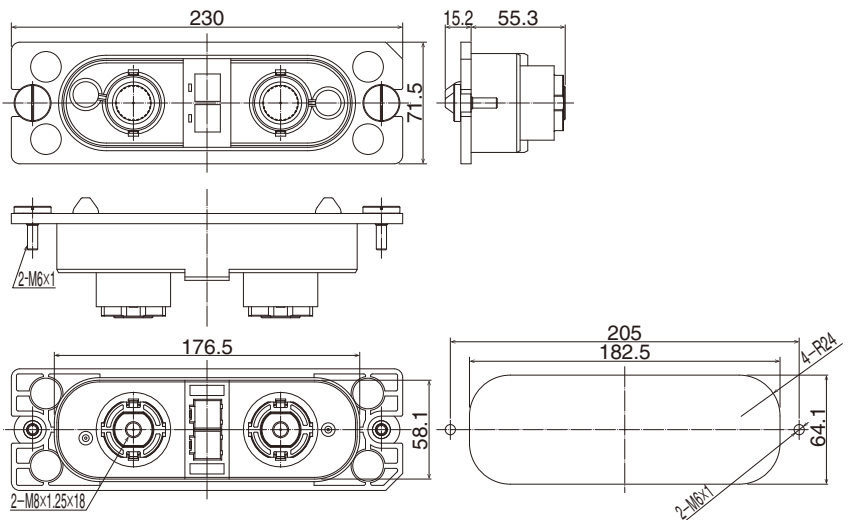

Crimp Contact Housing

Part No.	HRS No.	Sales Unit	RoHS
PS2-6PC	236-1034-4 00	100 pieces	○
PS2-6SC	236-1035-7 00		○
PS2-9PC	236-1038-5 00		○
PS2-9SC	236-1039-8 00		○

Part No.	HRS No.	Sales Unit	RoHS
PS2-18PC	236-1049-1 00	50 pieces	○
PS2-18SC	236-1050-0 00		○
PS2-42PC	236-1047-6 00		○
PS2-42SC	236-1048-9 00		○



●PS2-6PC

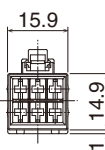
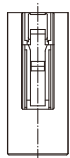

●PS2-6SC

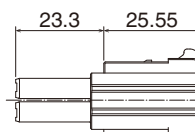
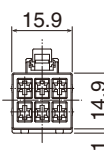
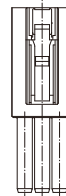

●PS2-9PC

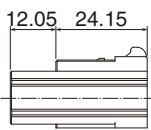
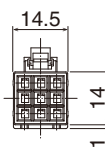
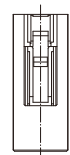

●PS2-9SC

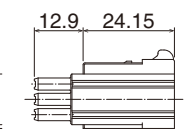
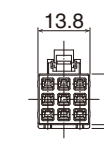
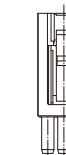

●PS2-18PC

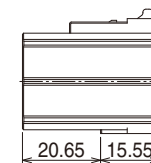
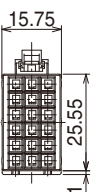
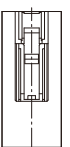

●PS2-18SC

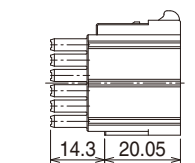
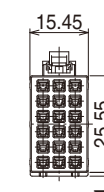
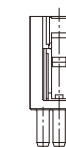

●PS2-42PC

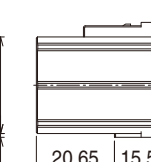
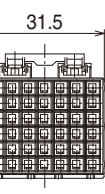
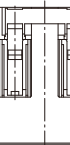

●PS2-42SC

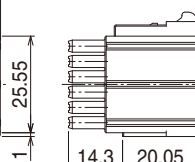
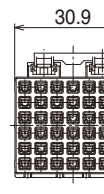
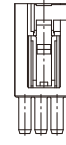

◆ Crimp Contact

Parts No.	HRS No.	Packaging	RoHS
PS2-1618PCFA	236-1028-1 00	3,500pcs/reel	○
PS2-1618PCA	236-1051-3 00	100pcs/pack	
PS2-1618SCFA	236-1029-4 00	3,500pcs/reel	
PS2-1618SCA	236-1052-6 00	100pcs/pack	
PQ50SA-1822PCFA	236-2029-0 00	6,000pcs/reel	
PQ50SA-1822PCA	236-2048-4 00	100pcs/pack	
PQ50SA-2428PCFA	236-2030-9 00	6,000pcs/reel	
PQ50SA-2428PCA	236-2049-7 00	100pcs/pack	
PQ50S-1822SCFA	236-2026-1 00	6,000pcs/reel	
PQ50S-1822SCA	236-2050-6 00	100pcs/pack	
PQ50S-2428SCFA	236-2028-7 00	6,000pcs/reel	
PQ50S-2428SCA	236-2051-9 00	100pcs/pack	

● PS2-1618PCFA

● PS2-1618SCFA

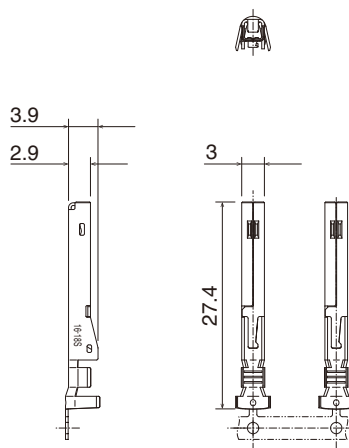
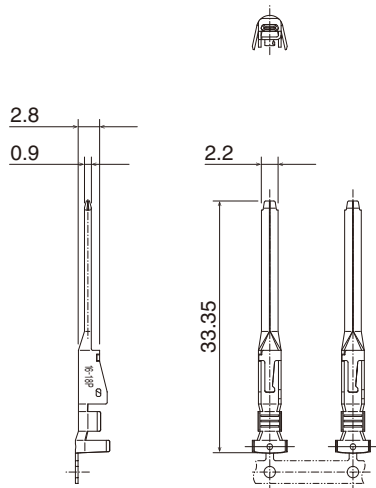

**● PQ50SA-1822PCFA
PQ50SA-2428PCFA**

**● PQ50S-1822SCFA
PQ50S-2428SCFA**

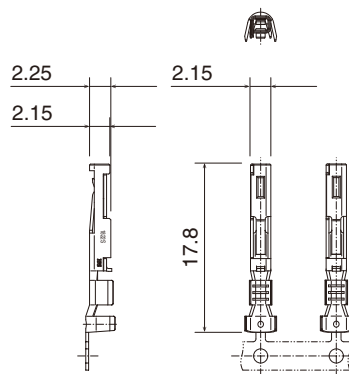
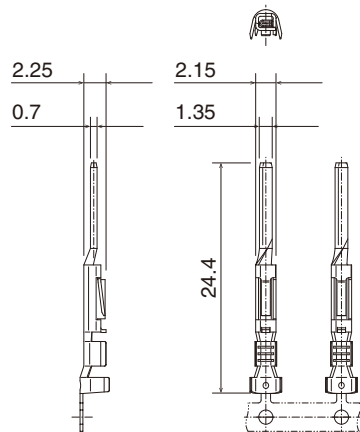

◆ Manual Crimp Tools

Target product	① Tool Frame Upper row : Part No. / Lower row : HRS No.	※ Die set		Applicable contacts	Applicable cables		
		Part No.	HRS No.				
100A type 200A type	HT702 250-1001-1	PQ50S-1820(1007)	250-1010-2	PQ50S-1822SCA	18 AWG		
		PQ50S-2022(1007)	250-1011-5		20 AWG		
		PQ50S-2022(1007)	250-1011-5		22 AWG		
		300A type	HT702 250-1001-1	PQ50SA-1820(1007)	250-1012-8	PQ50SA-1822PCA	18 AWG
				PQ50SA-2022(1007)	250-1013-0		20 AWG
				PQ50SA-2022(1007)	250-1013-0		22 AWG
		300A type	HT702 250-1001-1	PQ50S-2428(1007)	250-1029-0	PQ50S-2428SCA	24 AWG
				PQ50S-2428(1007)	250-1029-0		26 AWG
PQ50S-2428(1007)	250-1029-0			28 AWG			
300A type	HT702 250-1001-1	PQ50SA-2428(1007)	250-1030-0	PQ50SA-2428PCA	24 AWG		
		PQ50SA-2428(1007)	250-1030-0		26 AWG		
		PQ50SA-2428(1007)	250-1030-0		28 AWG		
300A type		PS2-1618(3385)	250-1014-3	PS2-1618PCA PS2-1618SCA	18 AWG		

Manual Crimp Tools

The Hirose hand tool for the PS2 series features replaceable die sets and parts. This allows you the ability to use one Hirose tool body and switch between the two Hirose die sets to crimp either of the PS2 terminals.

Due to wear, neglect or loss, replacement parts are also available for the Hirose die sets. Please see the chart at the bottom of page seven for these part numbers. Please be careful to select the correct replacement part based on the terminal and wire size you are trying to crimp. If you have any concern on the correct part to purchase, a Hirose sales representative will be glad to assist in selecting the correct part.

*Please refer to the bottom of page 8 and 9 for product numbers and descriptions.

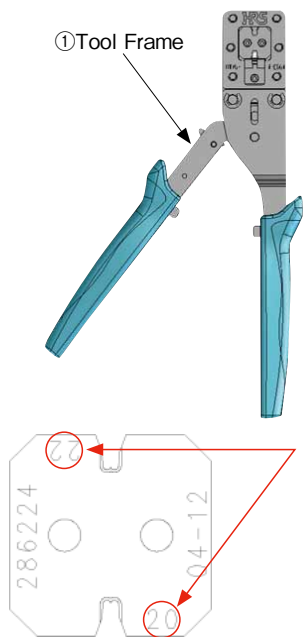

The wire crimper and insulation crimper are wire gauge specific. Each crimping location is marked on the part. Please make sure that you have each crimper orientated to the specific wire gauge you are using.

Part No.	HRS No.
HT702	250-1001-1 00

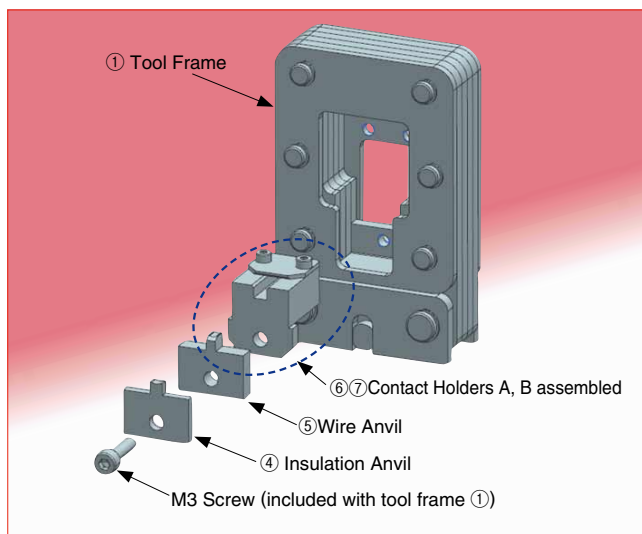
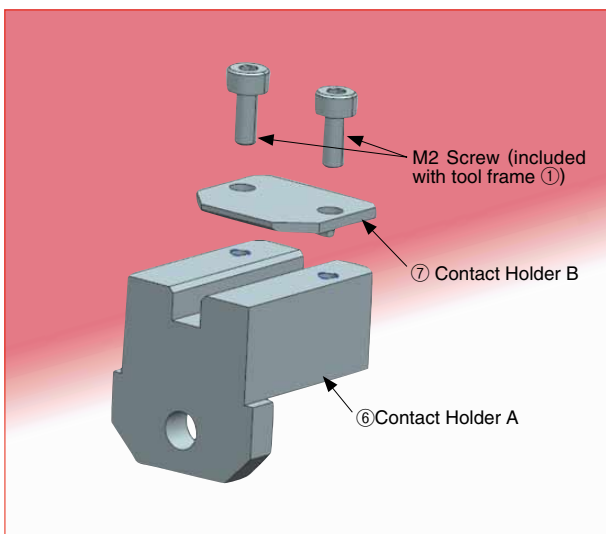
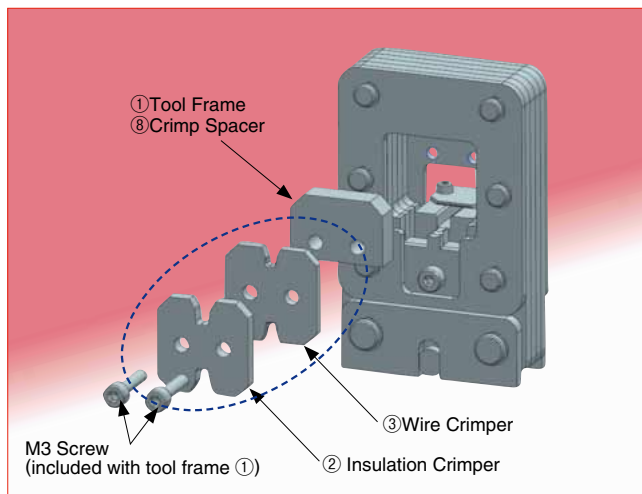

Automatic Crimper

Please call us.

Target product	Upper row : Part No. / Lower row : HRS No.							
	② IC Insulation Crimper	③ WC (Wire Crimper)	④ IA (Insulation Anvil)	⑤ WA (Wire Anvil)	⑥ Contact Holder A	⑥ Contact Holder B	⑦ Contact Holder C	⑧ Crimper Spacer
100A type 200A type	286219 [250-1010-2(61)]	286223 [250-1010-2(62)]	286225 [250-1010-2(63)]	286226 [250-1010-2(64)]	286233 [250-1010-2(65)]	286234 [250-1010-2(66)]		285996 [250-1010-2(67)]
	286220 [250-1011-5(61)]	286224 [250-1011-5(62)]	286225 [250-1011-5(63)]	286226 [250-1011-5(64)]	286233 [250-1011-5(65)]	286234 [250-1011-5(66)]		285996 [250-1011-5(67)]
	286219 [250-1012-8(61)]	286223 [250-1012-8(62)]	286225 [250-1012-8(63)]	286226 [250-1012-8(64)]	286233 [250-1012-8(65)]		286235 [250-1012-8(66)]	285996 [250-1012-8(67)]
	286220 [250-1013-0(61)]	286224 [250-1013-0(62)]	286225 [250-1013-0(63)]	286226 [250-1013-0(64)]	286233 [250-1013-0(65)]		286235 [250-1013-0(66)]	285996 [250-1013-0(67)]
	286876 [250-1029-0(61)]	286877 [250-1029-0(62)]	286231 [250-1029-0(63)]	286232 [250-1029-0(64)]	286233 [250-1029-0(65)]	286234 [250-1029-0(66)]		285996 [250-1029-0(67)]
	286876 [250-1030-0(61)]	286877 [250-1030-0(62)]	286231 [250-1030-0(63)]	286232 [250-1030-0(64)]	286233 [250-1030-0(65)]		286235 [250-1030-0(66)]	285996 [250-1030-0(67)]
300A type	286256 [250-1014-3(61)]	285991 [250-1014-3(62)]	285992 [250-1014-3(63)]	285993 [250-1014-3(64)]	286257 [250-1014-3(65)]	286258 [250-1014-3(66)]		285996 [250-1014-3(67)]

◆ Safety Standards Certifications (UL, C-UL, TÜV)

The PS3C, PS3CS series has received safety certifications from the UL, C-UL, and TÜV under the conditions provided in Table 1 and Table 2.

Table 1. Conditions for UL and C-UL

	100A Type Condition	200A Type Condition
Rated Voltage (AC/DC)	600V	
Rated Current	100A	200A
Cable	38sq, 2 AWG (Note 1)	80sq, 2/0 AWG (Note 1)
Creepage Distance (Note 2)	MIN : 3.2mm	
Clearance (Note 2)	MIN : 3.2mm	

Table 2. Conditions for TÜV

	100A Type Condition	200A Type Condition
Rated Voltage (AC/DC)	1000V	
Rated Current	100A	200A
Cable	38sq, 2 AWG	80sq, 2/0 AWG
Overvoltage Category	III	
Contamination Level	3	
Creepage Distance (Note 2)	MIN : 16mm	
Clearance (Note 2)	MIN : 8mm	
Insulation System	Basic insulation (Panel should be grounded)	

Note 1 : Use the crimp contact combination recommended below. The use of other crimp contacts can affect clearance and creepage distance.

If you choose to use a different contact combination, be sure to check the measurements for clearance and creepage. Make sure that these conditions will meet the UL, C-UL and TÜV.

- Recommended crimp contacts
- Cable 38sq : NICHIFU R38-6
- Cable 80sq : NICHIFU R80-8

Note 2 : Subjects of clearance and creepage distance are as follows.

- Between the power contacts.
- Between the signal contacts.
- Between power contact and signal contact.
- Between power contact and panel.
- Between signal contact and panel.

USA:

HIROSE ELECTRIC (U.S.A.), INC. HEADQUARTERS CHICAGO OFFICE
2300 Warrenville Road, Suite 150,
Downers Grove, IL 60515
Phone : +1-630-282-6700
<http://www.hirose.com/us/>

USA:

HIROSE ELECTRIC (U.S.A.), INC. SAN JOSE OFFICE
2841 Junction Ave, Suite 200
San Jose, CA. 95134
Phone : +1-408-253-9640
Fax : +1-408-253-9641
<http://www.hirose.com/us/>

USA:

HIROSE ELECTRIC (U.S.A.), INC. DETROIT OFFICE (AUTOMOTIVE)
17197 N. Laurel Park Drive, Suite 253,
Livonia, MI 48152
Phone : +1-734-542-9963
Fax : +1-734-542-9964
<http://www.hirose.com/us/>

THE NETHERLANDS:

HIROSE ELECTRIC EUROPE B.V.
Hogehillweg #8 1101 CC Amsterdam Z-O
Phone : +31-20-6557460
Fax : +31-20-6557469
<http://www.hirose.com/eu/>

GERMANY:

HIROSE ELECTRIC EUROPE B.V. GERMAN BRANCH
Schoenbergstr. 20, 73760 ostfildern
Phone : +49-711-456002-1
Fax : +49-711-456002-299
<http://www.hirose.com/eu/>

GERMANY:

HIROSE ELECTRIC EUROPE B.V. NUREMBERG OFFICE
Neumeyerstrasse 22-26, 90411 Nurnberg
Phone : +49-911 32 68 89 63
Fax : +49-911 32 68 89 69
<http://www.hirose.com/eu/>

GERMANY:

HIROSE ELECTRIC EUROPE B.V. HANOVER OFFICE
Bayernstr. 3, Haus C 30855 Langenhagen, Germany
Phone : +49-511 97 82 61 30
Fax : +49-511 97 82 61 35
<http://www.hirose.com/eu/>

FRANCE:

HIROSE ELECTRIC EUROPE B.V. PARIS OFFICE
Regus La Garenne Colombes, Place de La Belgique,
71 Boulevard National La Garenne Colombes, 92250, France
Phone : +33 (0) 1 7082 3170
Fax : +33 (1) 7082 3101
<http://www.hirose.com/eu/>

UNITED KINGDOM:

HIROSE ELECTRIC EUROPE BV (UK BRANCH)
4 Newton Court, Kelvin Drive, Knowlhill,
Milton Keynes, MK5 8NH
Phone : +44-1908 202050
Fax : +44-1908 202058
<http://www.hirose.com/eu/>

CHINA:

HIROSE ELECTRIC (SHANGHAI) CO., LTD.
1601, Henderson Metropolitan, NO.300, East Nanjing
Road, Huangpu District, Shanghai, China 200001
Phone : +86-21-6391-3355
Fax : +86-21-6391-3335
<http://www.hirose.com/cn/>

CHINA:

HIROSE ELECTRIC (SHANGHAI) CO., LTD. BEIJING BRANCH
A1001, Ocean International Center, Building 56# East 4th
Ring Middle Road, ChaoYang District, Beijing, 100025
Phone : +86-10-5165-9332
Fax : +86-10-5908-1381
<http://www.hirose.com/cn/>

CHINA:

HIROSE ELECTRIC TECHNOLOGIES (SHENZHEN) CO., LTD.
Room 09-13, 19/F, Office Tower Shun Hing Square, Di Wang Commercial Centre,
5002 Shen Nan Dong Road, Shenzhen City, Guangdong Province, 518008
Phone : +86-755-8207-0851
Fax : +86-755-8207-0873
<http://www.hirose.com/cn/>

HONG KONG:

HIROSE ELECTRIC HONGKONG TRADING CO., LTD.
Room 1001, West Wing, Tsim Sha Tsui Centre, 66
Mody Road, Tsim Sha Tsui East, Kowloon, Hong Kong
Phone : +852-2803-5338
Fax : +852-2591-6560
<http://www.hirose.com/hk/>

TAIWAN:

HIROSE ELECTRIC TAIWAN CO., LTD.
103 8F, No.87, Zhengzhou Rd., Taipei
Phone : +886-2-2555-7377
Fax : +886-2-2555-7350
<http://www.hirose.com/tw/>

KOREA:

HIROSE KOREA CO., LTD.
250, Huimanggongwon-ro, Siheung-si,
Gyeonggi-do, Korea, 15083
Phone : +82-31-496-7000 or 7124
Fax : +82-31-496-7100
<http://www.hirose.co.kr/>

SINGAPORE:

HIROSE ELECTRIC SINGAPORE PTE. LTD.
10 Anson Road #26-16, International Plaza
079903, Singapore
Phone : +65-6324-6113
Fax : +65-6324-6123
<http://www.hirose.com/sg/>

INDIA:

HIROSE ELECTRIC SINGAPORE PTE. LTD. DELHI LIAISON OFFICE
Office NO.552, Regus-Green Boulevard, Level5, Tower C,
Sec62, Plot B-9A, Block B, Noida, 201301, Uttar Pradesh, India
Phone : +91-12-660-8018
Fax : +91-120-4804949
<http://www.hirose.com/sg/>

INDIA:

HIROSE ELECTRIC SINGAPORE PTE. LTD. BANGALORE LIAISON OFFICE
Unit No-403, 4th Floor, No-84, Barton Centre, Mahatma
Gandhi (MG) Road, Bangalore 560 001, Karnataka, India
Phone : +91-80-4120 1907
Fax : +91-80-4120 9908
<http://www.hirose.com/sg/>

MALAYSIA:

PENANG REPRESENTATIVE OFFICE
1-21-01, Suntech @ Penang Cybercity (1164), Lintang
Mayang Pasir 3,11950, Bayan Baru, Penang, Malaysia.
Phone : +604-619-2564
Fax : +604-619-2574
<http://www.hirose.com/sg/>

THAILAND:

BANGKOK OFFICE (REPRESENTATIVE OFFICE)
Unit 4703, 47th FL., 1 Empire Tower, South Sathorn
Road, Yannawa, Sathorn, Bangkok 10120 Thailand
Phone : +66-2-686-1255
Fax : +66-2-686-3433
<http://www.hirose.com/sg/>

**HIROSE ELECTRIC CO., LTD.**

2-6-3, Nakagawa Chuoh, Tsuzuki-Ku, Yokohama-Shi 224-8540, JAPAN
TEL: +81-45-620-3526 Fax: +81-45-591-3726
<http://www.hirose.com>
<http://www.hirose-connectors.com>