

ASSP Mobile Communication Systems

**SAW Duplexer
(700 to 1000 MHz)****D5CC Series (D1)****DESCRIPTION**

The D5CC series of SAW antenna duplexer apply to the frequency range 700 to 1000 MHz. These SAW filters are fabricated on a lithium tantalate (LiTaO₃) substrate, producing small size and light duplexer. And its high performances is realized by using original design and patterning technology. The D5CC series with of transmitter filter, receiver filter and matching circuit are housed in a small package, so it can contribute to save mounting space and weight.

FEATURES

- Ultra compact and light package (0.14cc, 9.5 × 7.5 × 2.0 (h) mm typ.)
- External matching circuits are not required.
- Surface mount package (SMT)
- High handling power resistance (1.2 W max.)

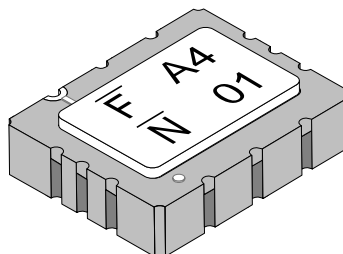
PACKAGE

D5CC Series (D1)

■ PIN ASSIGNMENT

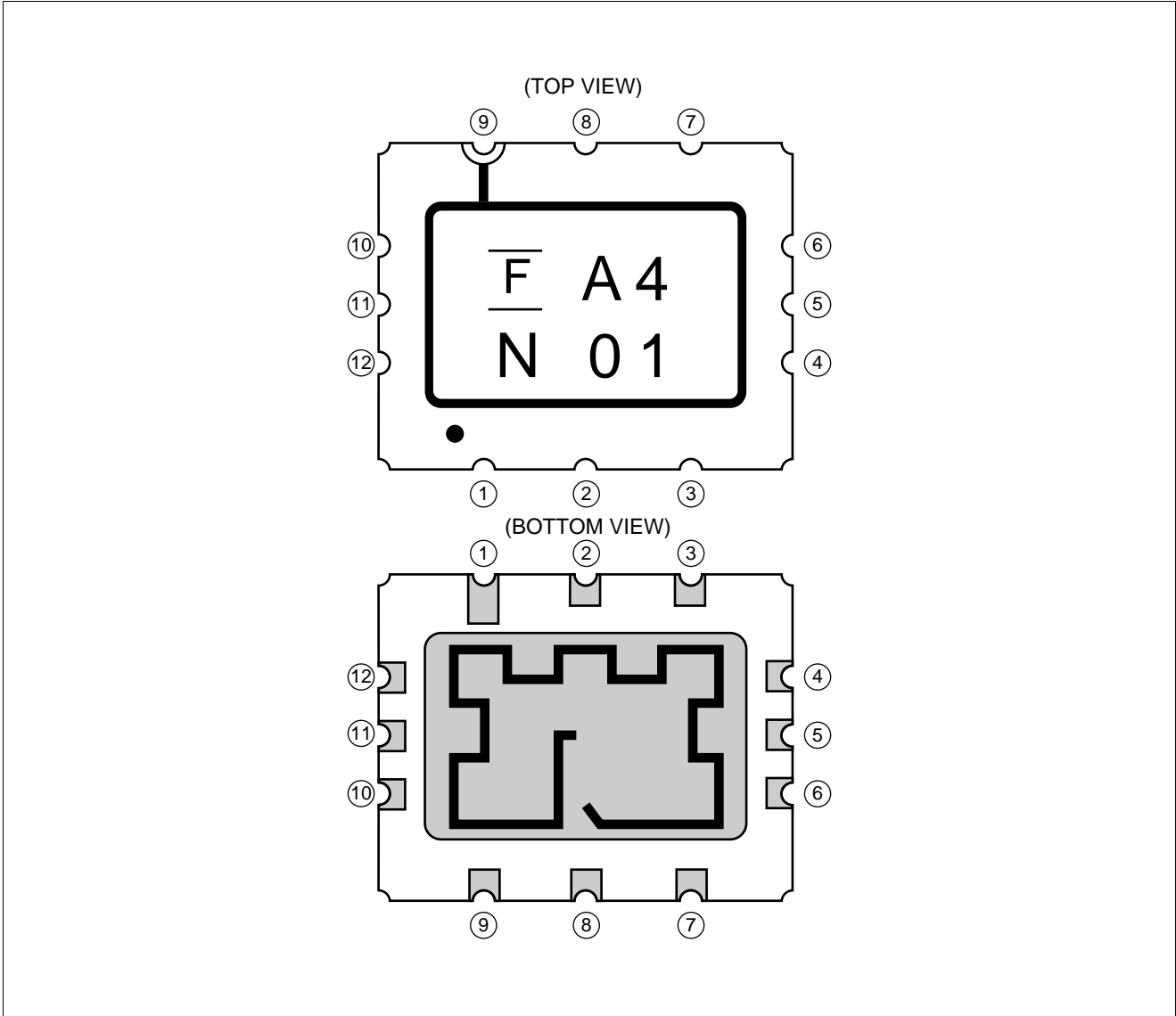

■ PIN DESCRIPTION

Pin No.	Pin name	Description
1	GND	Ground Pin
2	ANT	Antenna Pin*
3	GND	Ground Pin
4	GND	Ground Pin
5	Rx	Receiver side Pin
6	GND	Ground Pin
7	GND	Ground Pin
8	ANT	Antenna Pin*
9	GND	Ground Pin
10	GND	Ground Pin
11	Tx	Transmitter side Pin
12	GND	Ground Pin

* : Only one Antenna input pad should be connected.
The other Antenna pad doesn't need to be connected.

D5CC Series (D1)

■ ABSOLUTE MAXIMUM RATINGS

Parameter	Symbol	Rating		Unit
		Min.	Max.	
Operating temperature	Ta	-30	+85	°C
Storage temperature	Tstg	-40	+100	°C
Maximum input power	P _{IN}	—	1.2	W

WARNING: Semiconductor devices can be permanently damaged by application of stress (voltage, current, temperature, etc.) in excess of absolute maximum ratings. Do not exceed these ratings.

■ RECOMMENDED OPERATING CONDITIONS

Parameter	Symbol	Value		Unit
		Min.	Max.	
Operating temperature	Ta	-30	+85	°C

WARNING: Recommended operating conditions are normal operating ranges for the semiconductor device. All the device's electrical characteristics are warranted when operated within these ranges.

Always use semiconductor devices within the recommended operating conditions. Operation outside these ranges may adversely affect reliability and could result in device failure.

No warranty is made with respect to uses, operating conditions, or combinations not represented on the data sheet. Users considering application outside the listed conditions are advised to contact their FUJITSU representative beforehand.

■ STANDARD FREQUENCIES

System	Tx freq. (MHz)	Rx freq. (MHz)	Part number	Part symbol	Remarks
AMPS/IS-95/ IS-136	824 to 849	869 to 894	FAR-D5CC-881M50-D1A2	A2	Low insertion loss at Rx side
			FAR-D5CC-881M50-D1A4	A4	High attenuation at Tx band

D5CC Series (D1)

■ ELECTRICAL CHARACTERISTICS

AMPS/IS-136/IS-95

1. Part number: FAR-D5CC-881M50-D1A2

(Ta = -30 to +85°C)

Parameter	Symbol	Condition	Value			Unit	Remarks	
			Min.	Typ.	Max.			
Tx → Antenna	Insertion Loss	IL	824 to 849 MHz	—	2.3	2.7	dB	
	Inband Ripple	—	824 to 849 MHz	—	1.0	1.5	dB	
	VSWR	—	824 to 849 MHz	—	1.9	2.3		
	Absolute Attenuation	—	779 to 804 MHz	12	15	—	dB	
		—	869 to 894 MHz	40	45	—	dB	
		—	1648 to 1698 MHz	10	13	—	dB	
		—	2472 to 2547 MHz	4	5	—	dB	
Antenna → Rx	Insertion Loss	IL	869 to 894 MHz	—	3.0	3.8	dB	
	Inband Ripple	—	869 to 894 MHz	—	1.5	2.5	dB	
	VSWR	—	869 to 894 MHz	—	2.2	2.5	—	
	Absolute Attenuation	—	824 to 849 MHz	40	42	—	dB	
—		930 to 1800 MHz	22	27	—	dB		
Tx → Rx	Absolute Attenuation (Isolation)	—	824 to 849 MHz	40	43	—	dB	
		—	869 to 894 MHz	45	50	—	dB	
Maximum Input Power		—	1.2 W (Condition, continuous wave at +50°C for 50000Hrs)					

D5CC Series (D1)

• Typical Characteristics

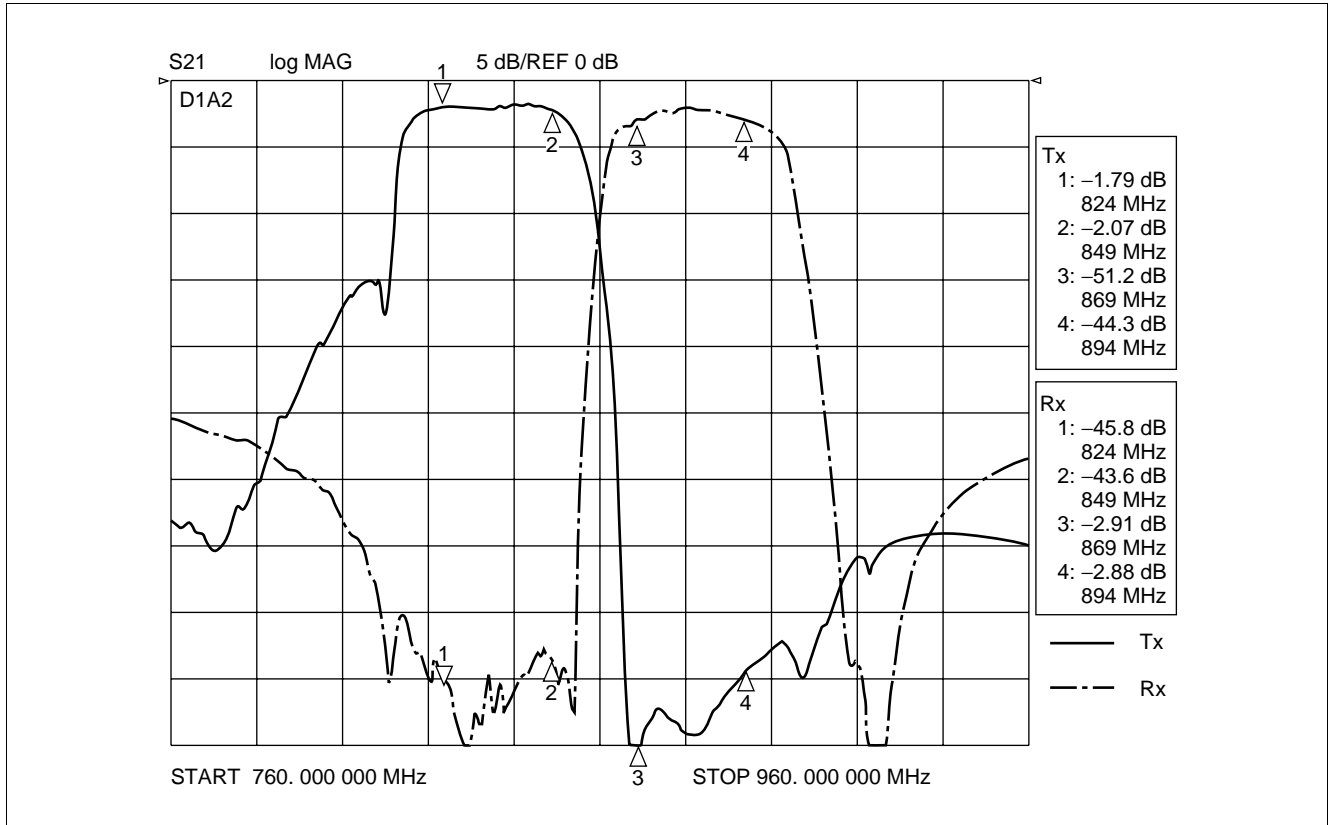

D5CC Series (D1)

2. Part number: FAR-D5CC-881M50-D1A4

(Ta = -30 to +85°C)

Parameter		Symbol	Condition	Value			Unit	Remarks	
				Min.	Typ.	Max.			
Tx → Antenna	Insertion Loss	IL	824 to 849 MHz	—	2.0	2.5	dB		
	Inband Ripple	—	824 to 849 MHz	—	1.0	1.5	dB		
	VSWR	—	824 to 849 MHz	—	1.8	2.5	—		
	Absolute Attenuation	—	—	779 to 804 MHz	12	17	—	dB	
		—	—	869 to 894 MHz	40	46	—	dB	
		—	—	1648 to 1698 MHz	10	12	—	dB	
		—	—	2472 to 2547 MHz	4	5	—	dB	
Antenna → Rx	Insertion Loss	IL	869 to 894 MHz	—	3.8	4.3	dB		
	Inband Ripple	—	869 to 894 MHz	—	1.5	2.5	dB		
	VSWR	—	869 to 894 MHz	—	2.3	2.7	—		
	Absolute Attenuation	—	—	824 to 849 MHz	50	55	—	dB	
		—	—	930 to 1200 MHz	35	38	—	dB	
		—	—	1200 to 1500 MHz	33	37	—	dB	
		—	—	1500 to 1800 MHz	35	40	—	dB	
Tx → Rx	Absolute Attenuation (Isolation)	—	824 to 849 MHz	50	52	—	dB		
		—	869 to 894 MHz	46	49	—	dB		
Maximum Input Power		—	1.2 W (Condition, continuous wave at +50°C for 50000Hrs)						

D5CC Series (D1)

• Typical Characteristics

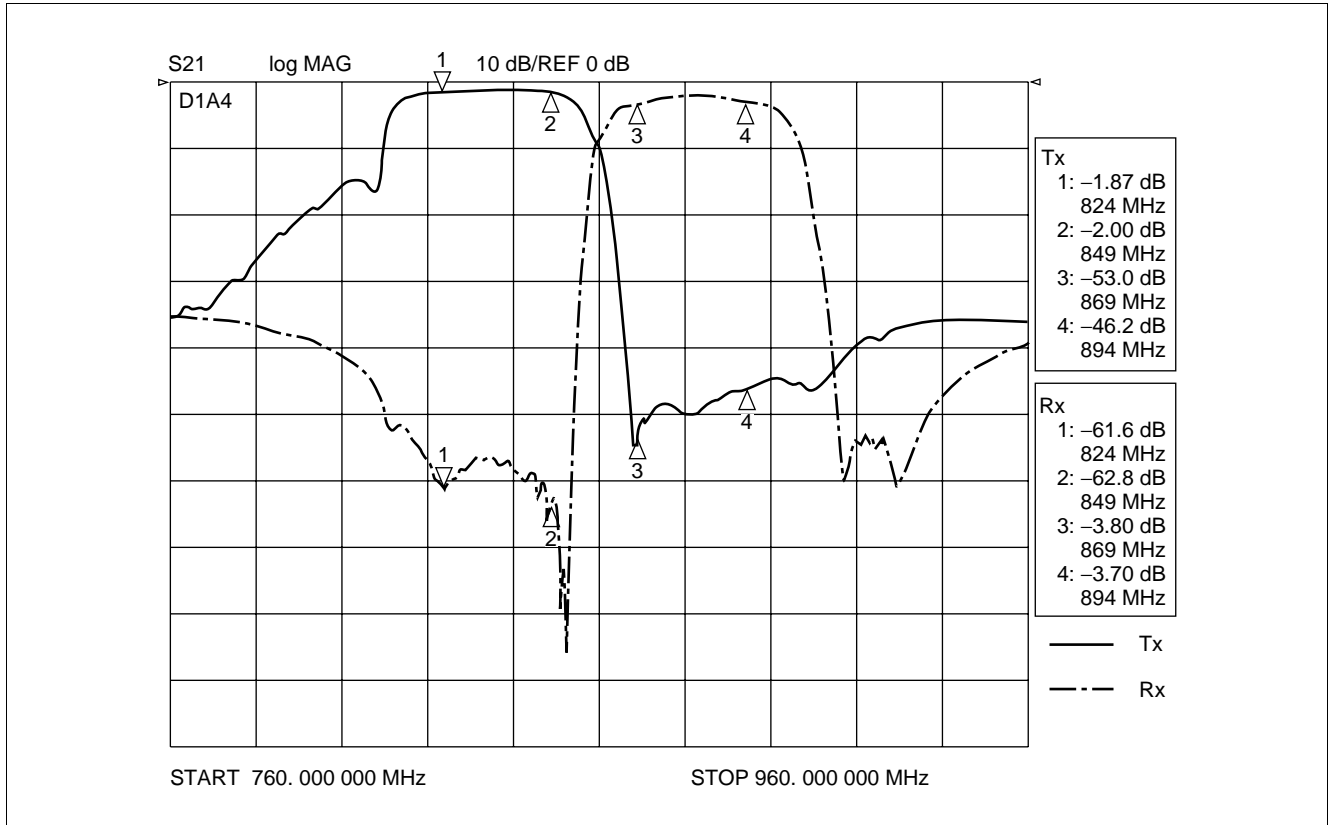

MEASUREMENT CIRCUIT

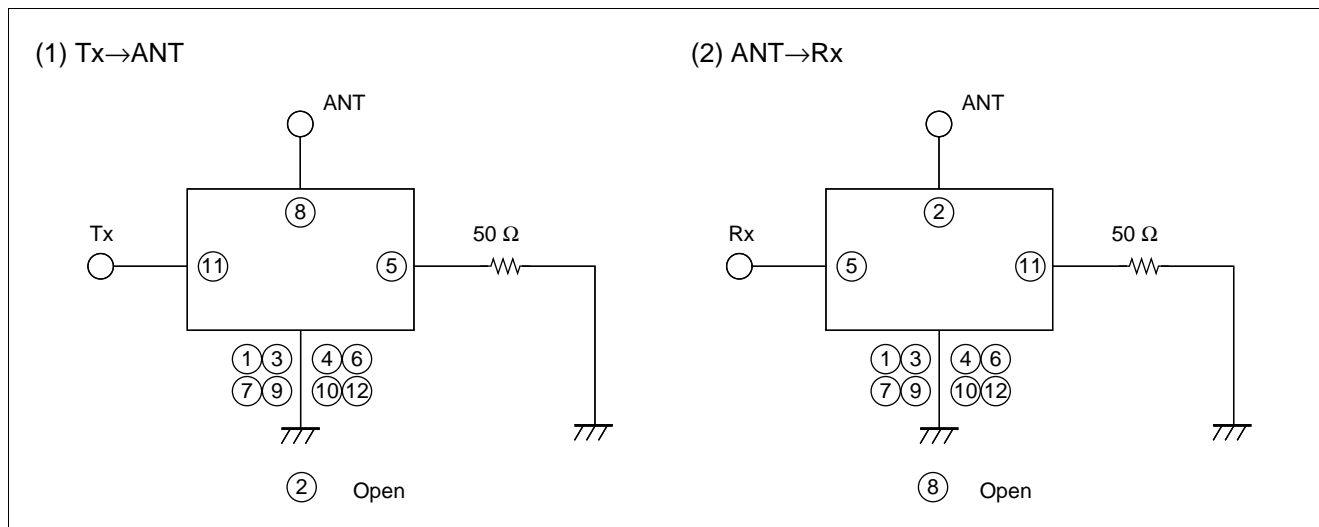

PART NUMBER DESIGNATION

[Designation example]

FAR-D5CC-□□□□□□-D1□□-□
 (1) (2) (3)

- (1)Frequency: Specify the nominal center frequency of higher frequency side in six alphanumeric. Enter M (for MHz) at the decimal point. Refer to below example.
 [Example] 881.5 MHz → 881M50
- (2)Part symbol: Specified characters from A1 to Z9.
- (3)Packing: T: 1 k pcs/reel

MARKING

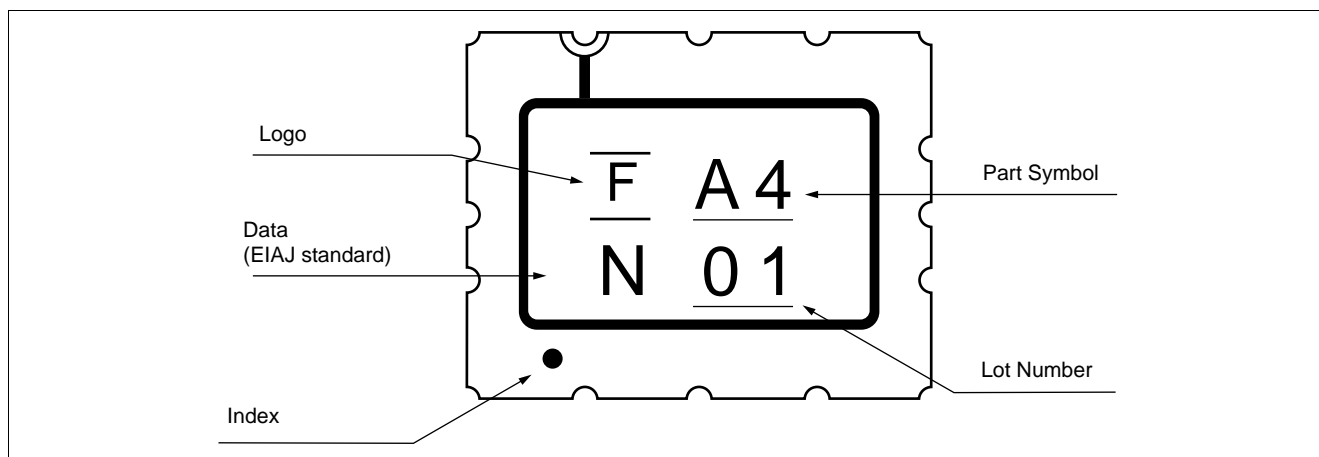

D5CC Series (D1)

■ PACKAGE DIMENSION

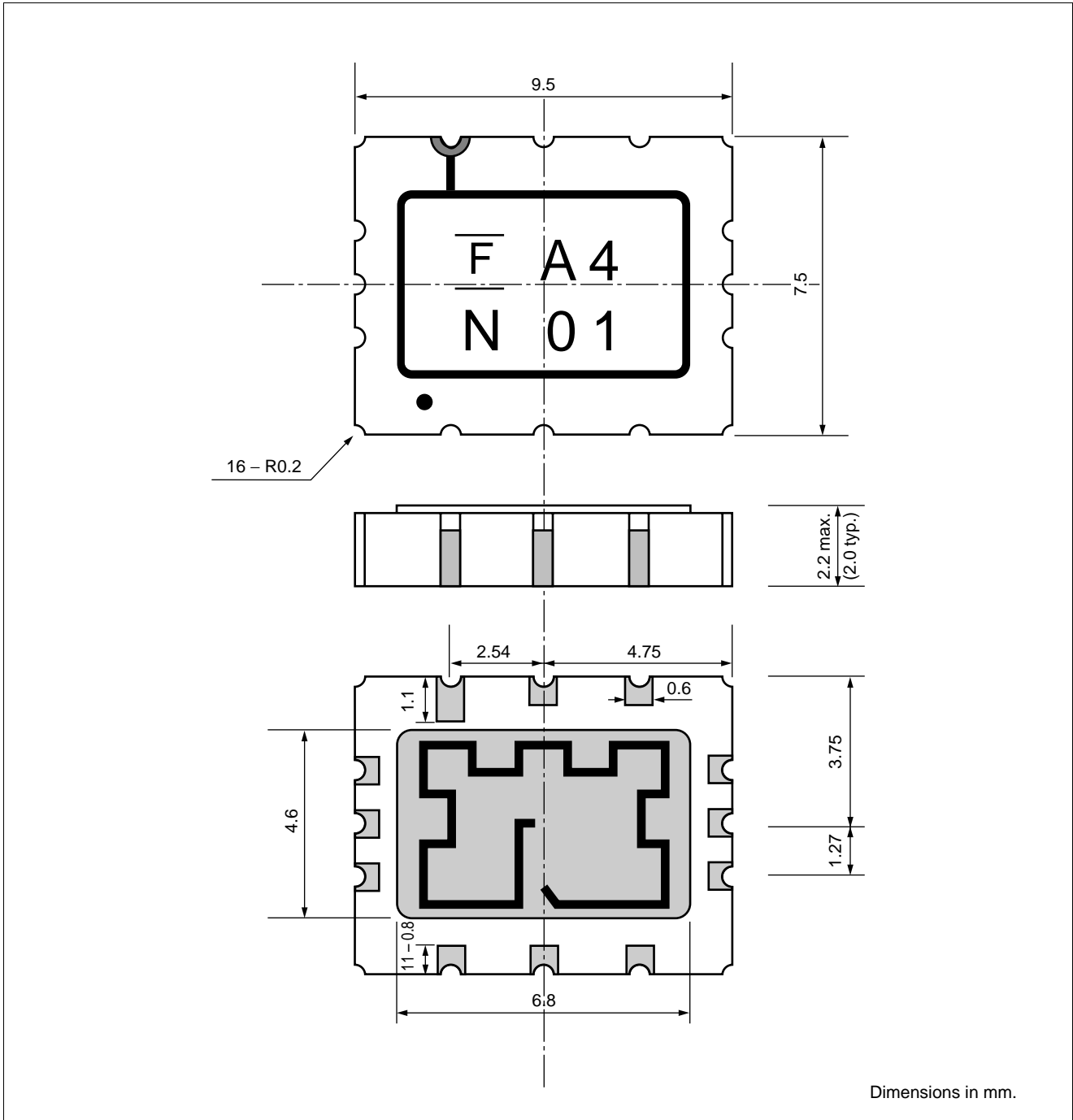

D5CC Series (D1)

■ PACKING: Reel type

(1) Reel Dimensions

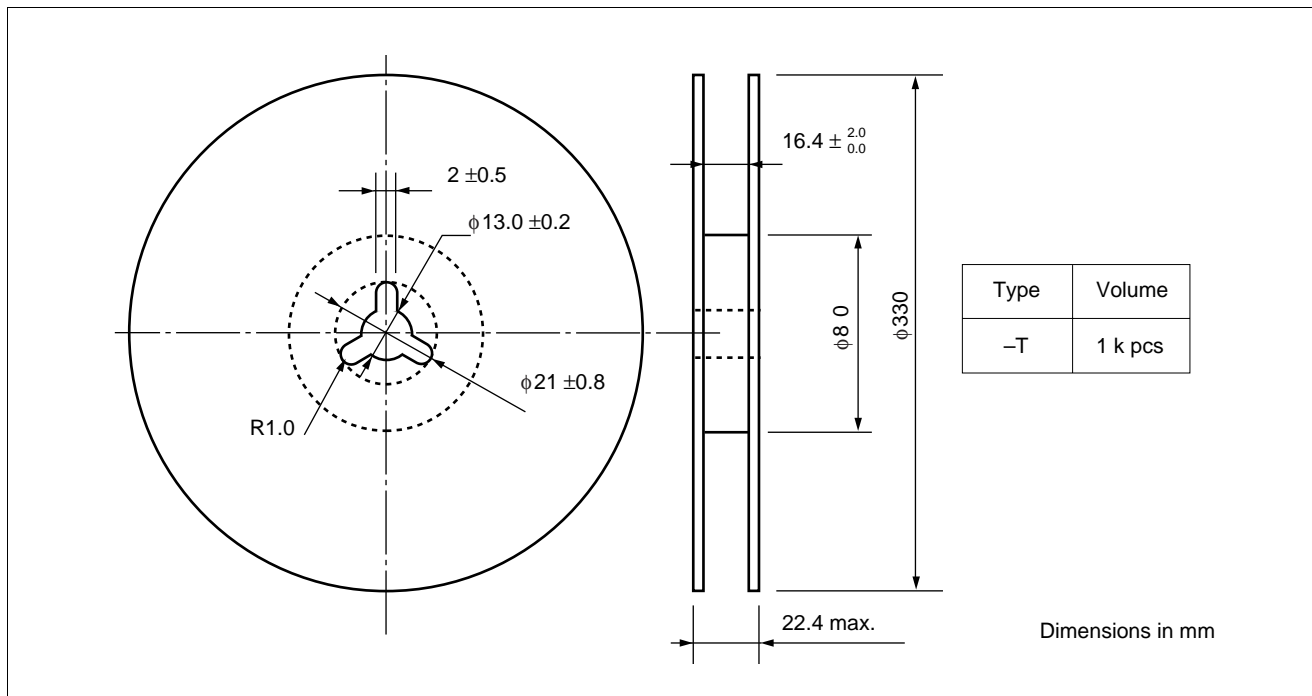

(2) Packing Style

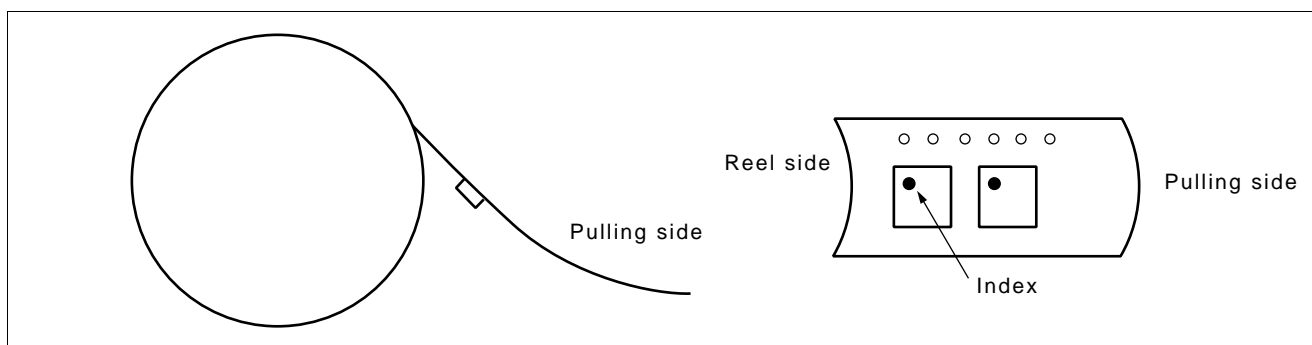

(3) Tape Dimensions

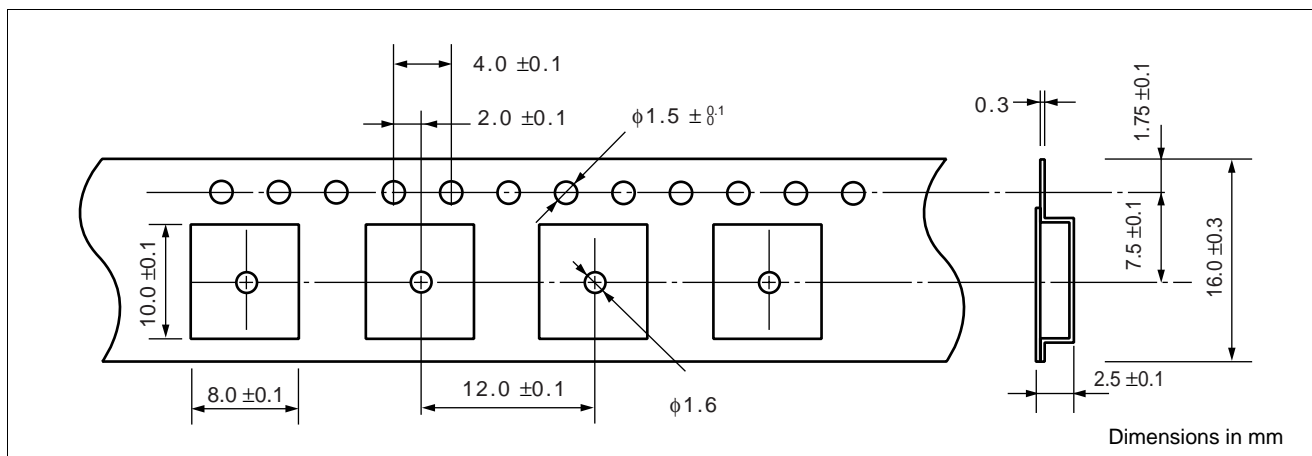

D5CC Series (D1)

FUJITSU LIMITED

For further information please contact:

Japan

FUJITSU LIMITED
Corporate Global Business Support Division
Electronic Devices
KAWASAKI PLANT, 4-1-1, Kamikodanaka
Nakahara-ku, Kawasaki-shi
Kanagawa 211-8588, Japan
Tel: (044) 754-3763
Fax: (044) 754-3329

<http://www.fujitsu.co.jp/>

North and South America

FUJITSU MICROELECTRONICS, INC.
Semiconductor Division
3545 North First Street
San Jose, CA 95134-1804, USA
Tel: (408) 922-9000
Fax: (408) 922-9179

Customer Response Center
Mon. - Fri.: 7 am - 5 pm (PST)
Tel: (800) 866-8608
Fax: (408) 922-9179

<http://www.fujitsumicro.com/>

Europe

FUJITSU MIKROELEKTRONIK GmbH
Am Siebenstein 6-10
D-63303 Dreieich-Buchsschlag
Germany
Tel: (06103) 690-0
Fax: (06103) 690-122

<http://www.fujitsu-edc.com/>

Asia Pacific

FUJITSU MICROELECTRONICS ASIA PTE LTD
#05-08, 151 Lorong Chuan
New Tech Park
Singapore 556741
Tel: (65) 281-0770
Fax: (65) 281-0220

<http://www.fmap.com.sg/>

F9802

© FUJITSU LIMITED Printed in Japan

All Rights Reserved.

The contents of this document are subject to change without notice. Customers are advised to consult with FUJITSU sales representatives before ordering.

The information and circuit diagrams in this document presented as examples of semiconductor device applications, and are not intended to be incorporated in devices for actual use. Also, FUJITSU is unable to assume responsibility for infringement of any patent rights or other rights of third parties arising from the use of this information or circuit diagrams.

FUJITSU semiconductor devices are intended for use in standard applications (computers, office automation and other office equipment, industrial, communications, and measurement equipment, personal or household devices, etc.).

CAUTION:

Customers considering the use of our products in special applications where failure or abnormal operation may directly affect human lives or cause physical injury or property damage, or where extremely high levels of reliability are demanded (such as aerospace systems, atomic energy controls, sea floor repeaters, vehicle operating controls, medical devices for life support, etc.) are requested to consult with FUJITSU sales representatives before such use. The company will not be responsible for damages arising from such use without prior approval.

Any semiconductor devices have inherently a certain rate of failure. You must protect against injury, damage or loss from such failures by incorporating safety design measures into your facility and equipment such as redundancy, fire protection, and prevention of over-current levels and other abnormal operating conditions.

If any products described in this document represent goods or technologies subject to certain restrictions on export under the Foreign Exchange and Foreign Trade Control Law of Japan, the prior authorization by Japanese government should be required for export of those products from Japan.