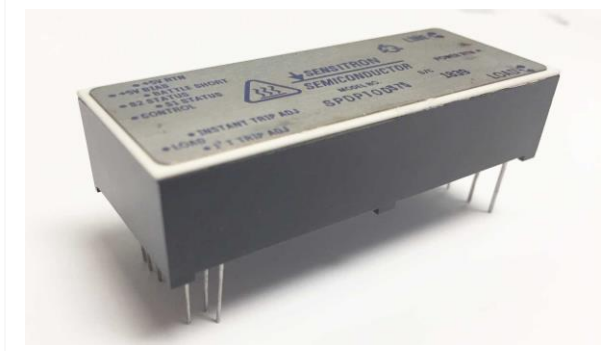

**SENSITRON**  
**SEMICONDUCTOR**PART NUMBER: SPDP03D270/SPDP03D375  
DATASHEET 5224, Rev. -**DC Solid State Power Controller Module****Description:**

The SPDP03D375 Solid State Power Controller (SSPC) Module is designed to operate without any heat sink requirements. It is a microcontroller-based Solid State Relay rated up to 3A, designed to be used in high reliability 375V DC applications. This module has an integrated current sensing with no de-rating over the full operating temperature range, and works as an electronic equivalent to an electromechanical circuit breaker with isolated control and status.

This module is programmable from 0.9A to 3A, and also allows programming the Instant Trip level from 400% to 700% of maximum rating.

**Compliant Documents & Standards:**

MIL-STD-704F	Aircraft Electrical Power Characteristics, 12 March 2004
MIL-STD-217F, Notice 2	Reliability Prediction of Electronic Equipment, 28 Feb 1995

**Features:**

- No additional heat sinking required.
- No derating Over the Full Temperature Range
- Low Weight (40 gms)
- Epoxy Shell Construction
- Solid State Reliability
- High Power Density
- Survives short circuit
- Battleshort input

**Benefits:**

Sensitron's SSPC technology and products combine functionalities of electro-mechanical breakers, solid state relays and system monitors and provide the following benefits to our customers:

- Electrical load protection and monitoring - current, voltage and temperature measurements
- Operational improvements by allowing for diagnostics, prognostics and condition-based configuration
- Life cycle cost savings and reduced cost of ownership
- Increased radius of operation through power budgeting and load shedding
- Crew offloading and intelligent load management

**Electrical Features (SPDPXXD375 Series):**

- 375VDC Input with Very Low Voltage Drop; 110mV, typ. @ 3A for SPDP03D375
- True I<sup>2</sup>t Protection up to 7X rating with Nuisance Trip Suppression
- I<sup>2</sup>t Protection level externally programmable to 30% of the maximum rating
- Instant Trip Protection level externally programmable from 400% to 700% of maximum rating
- Reports Loss of Line Voltage

**SENSITRON**  
**SEMICONDUCTOR**

**PART NUMBER: SPDP03D270/SPDP03D375**

**DATASHEET 5224, Rev. -**

- Reports Over Temperature condition and turns off during this condition
- Output Leakage Sink for safe output voltage when SPDP03D375 turned off
- No trip operation up to 40  $\mu$ F of output capacitance,
- Instant Trip Protection (250  $\mu$ sec typ.) for Loads Above programmed Instant Trip level
- Unlimited Interrupt Capability; Repetitive Fault Handling Capability
- Thermal Memory
- Internally Generated Isolated Supply to Drive the Switch
- Low Bias Supply Current: 75 mA typ. @ 5V DC
- High Control Circuit Isolation: 750V DC Control to Power Circuit
- Soft Turn-On to Reduce EMC Issues
- EMI Tolerant
- Module Reset with a Low Level Signal; Reset Circuit is Trip-Free
- TTL/CMOS Compatible, Optically Isolated, Input and Outputs
- Schmitt-Trigger Control Input for Noise Immunity

**Table 1 - Electrical Characteristics** (at 25 °C and  $V_{bias} = 5.0V$  DC unless otherwise specified)

<b>Control &amp; Status (TTL/CMOS Compatible)</b>	
BIAS ( $V_{cc}$ )	5.0V DC Nominal, 5.5V DC Absolute Maximum 4.5V to 5.5 VDC
BIAS ( $V_{cc}$ ) Current	75 mA typ 100 mA max
S1 and S2 Status Signals	$V_{oh}=4.6V$ min, at $I_{oh}=-4mA$ $V_{ol}=0.4V$ max, at $I_{ol}=4mA$
CONTROL, Battle Short Signal Input	$V_{IL} = 0V$ to 0.8V measured w.r.t Bias Rtn $V_{IH} = 2.0V$ to 5V measured w.r.t Bias Rtn
Reset	Cycle CONTROL Signal

<b>Power</b>	
Input Voltage – Continuous – Transient	0 to 425V DC, 500V DC Absolute Maximum +600V or –600V Spike ( $\leq 10 \mu$ sec)
Power Dissipation	See Table 4
Current	See Table 4 See Figure 1, Trip Curve
Max Voltage Drop	See Table 4
Trip time	See Figure 1, Trip Curve
Output Rise Time (turn ON)	2000 $\mu$ sec typ
Output Fall Time under normal turn-off	500 $\mu$ sec typ
Output Fall Time under short	50 $\mu$ sec typ
Min Load Requirement	Nil
<b>Protection</b>	
Short Circuit Protection	Unlimited
Instant Trip	400% - 700%, programmable

**Table 2 - Physical Characteristics**

<b>Temperature</b>	
Operating Temperature	$T_A = -40 \text{ }^\circ\text{C}$ to $+100 \text{ }^\circ\text{C}$
Storage Temperature	$T_A = -55 \text{ }^\circ\text{C}$ to $+125 \text{ }^\circ\text{C}$

**SENSITRON**  
**SEMICONDUCTOR**

PART NUMBER: SPDP03D270/SPDP03D375  
 DATASHEET 5224, Rev. -

<b>Environmental</b>	
Altitude	Up to 30,000 ft. Can be installed in an unpressurized area
Case Dimensions	2.50"L x 1.00"W x 0.50"H
Operating Orientation	Any
Weight	40 gms
MTBF (Estimate: MIL STD 217F)	TBD hrs at 25°C Full load

**Pin Descriptions**

**+5V BIAS:** Power supply for the SPDP unit  
**+5V RTN:** Power return for the SPDP unit  
**BATTLE SHORT:** Battle short command. The SPDP will be forced on when this pin has been commanded high  
**S1 STATUS:** Status indication output  
**S2 STATUS:** Status indication output  
**CONTROL:** Controls the SPDP on and off, active high  
**INSTANT TRIP ADJ:** This pin programs the instant trip level from 400% to 700% of the rating by putting a resistor between this pin to LOAD.  
**I<sup>2</sup>T TRIP ADJ:** This pin programs the I<sup>2</sup>T trip level from 30% to 100% of the rating by putting a resistor between this pin to the LOAD  
**LOAD:** Connect LOAD to this pin  
**LINE:** Connect Input Line voltage to this pin  
**POWER RTN:** This pin controls the turn on/off speed, and also discharges the LOAD when the SPDP is off, while it has been connected to Power Return.

**I<sup>2</sup>T TRIP curve**

I<sup>2</sup>T current trip is guaranteed to happen when the input current is higher than 145% of the configured rating, and guaranteed not to happen when the input current is below 115% of the programmed rating. Trip time is described in Figure 1.a and Figure 1.b. Please notice that if the instant trip level has been configured lower than 700%, any current above the instant trip point will cause a immediately turn off. In both figures, the Y axis is referenced to the programmed current rating. For example, in Figure 1.b, 100% on Y axis means 30% of 3A.

PART NUMBER: SPDP03D270/SPDP03D375  
DATASHEET 5224, Rev. -

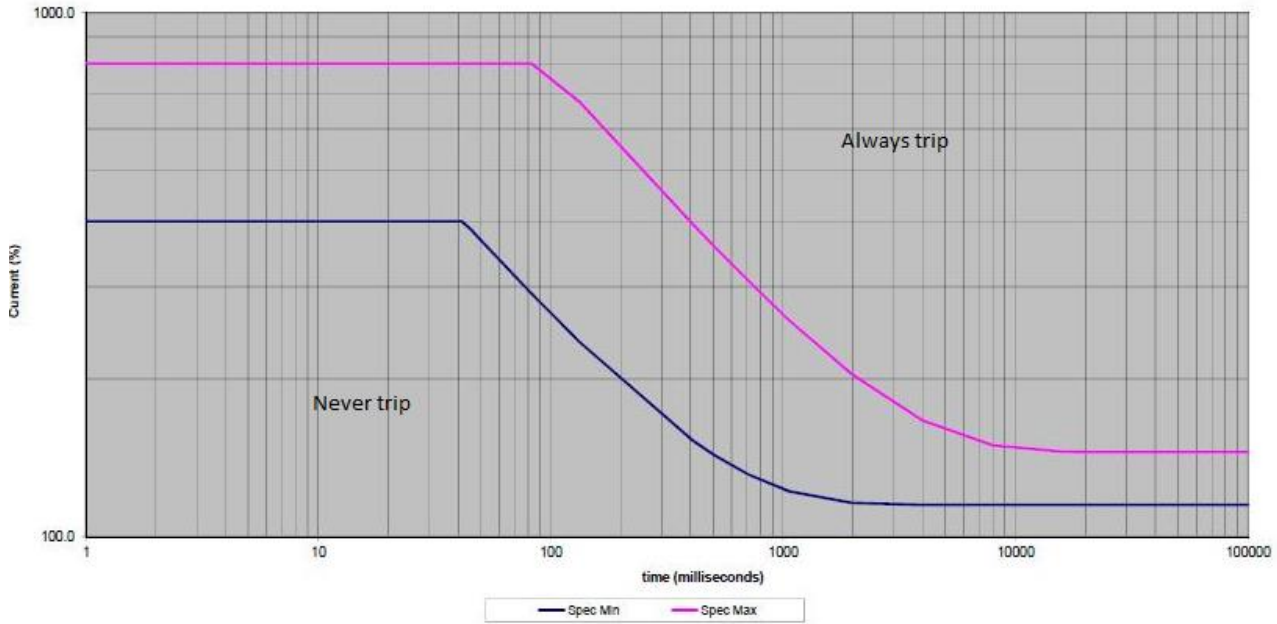

Figure 1.a - Trip Curve for 100% configuration

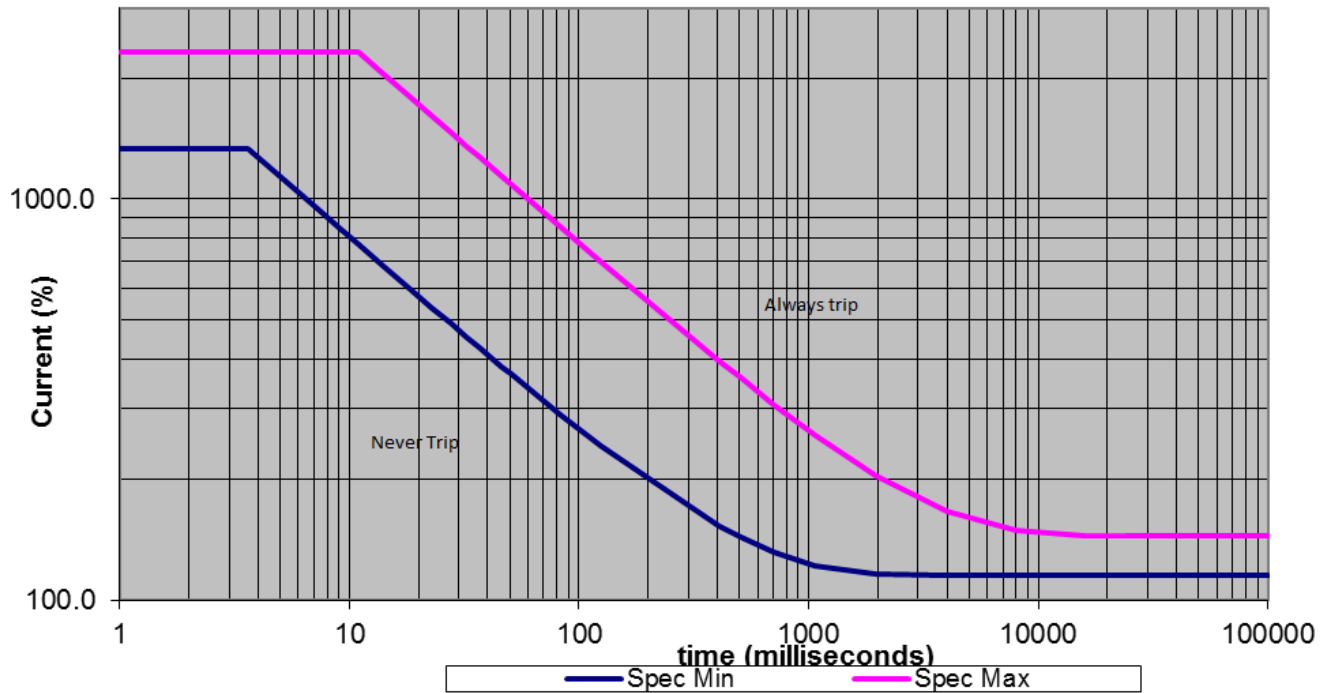

Figure 1.b - Trip Curve for 30% configuration

PART NUMBER: SPDP03D270/SPDP03D375  
DATASHEET 5224, Rev. -

**Table 3 - Signal Timing – (-40 °C to 100 °C @ LINE = 375V DC)**

Parameter	Symbol	Min (μs)	Max (μs)
CONTROL to GATE Status Delay for Turn On	t0	100	450
Turn ON Delay	t1	150	600
Load Current Rise Time	t2	1000	2500
CONTROL to GATE Status Delay for Turn Off	t3	1200	2000
CONTROL to current start to decrease	t4	1200	2000
Load voltage Fall Time	t5	200	700

Note: Current Falling Time from trip dependent on magnitude of overload

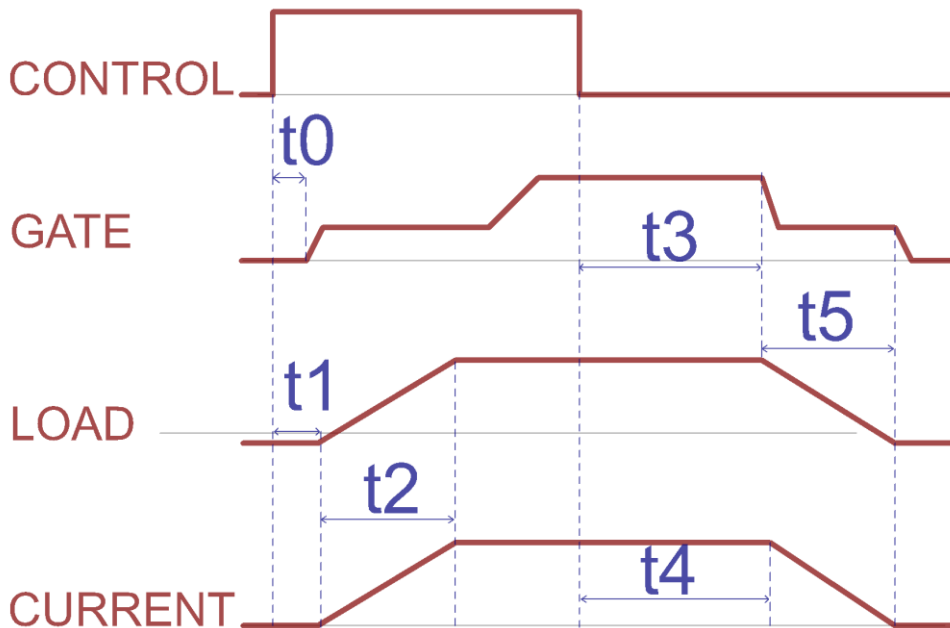

**SENSITRON**  
**SEMICONDUCTOR**

SPDP03D270  
SPDP03D375

PART NUMBER: SPDP03D270/SPDP03D375  
DATASHEET 5224, Rev. -

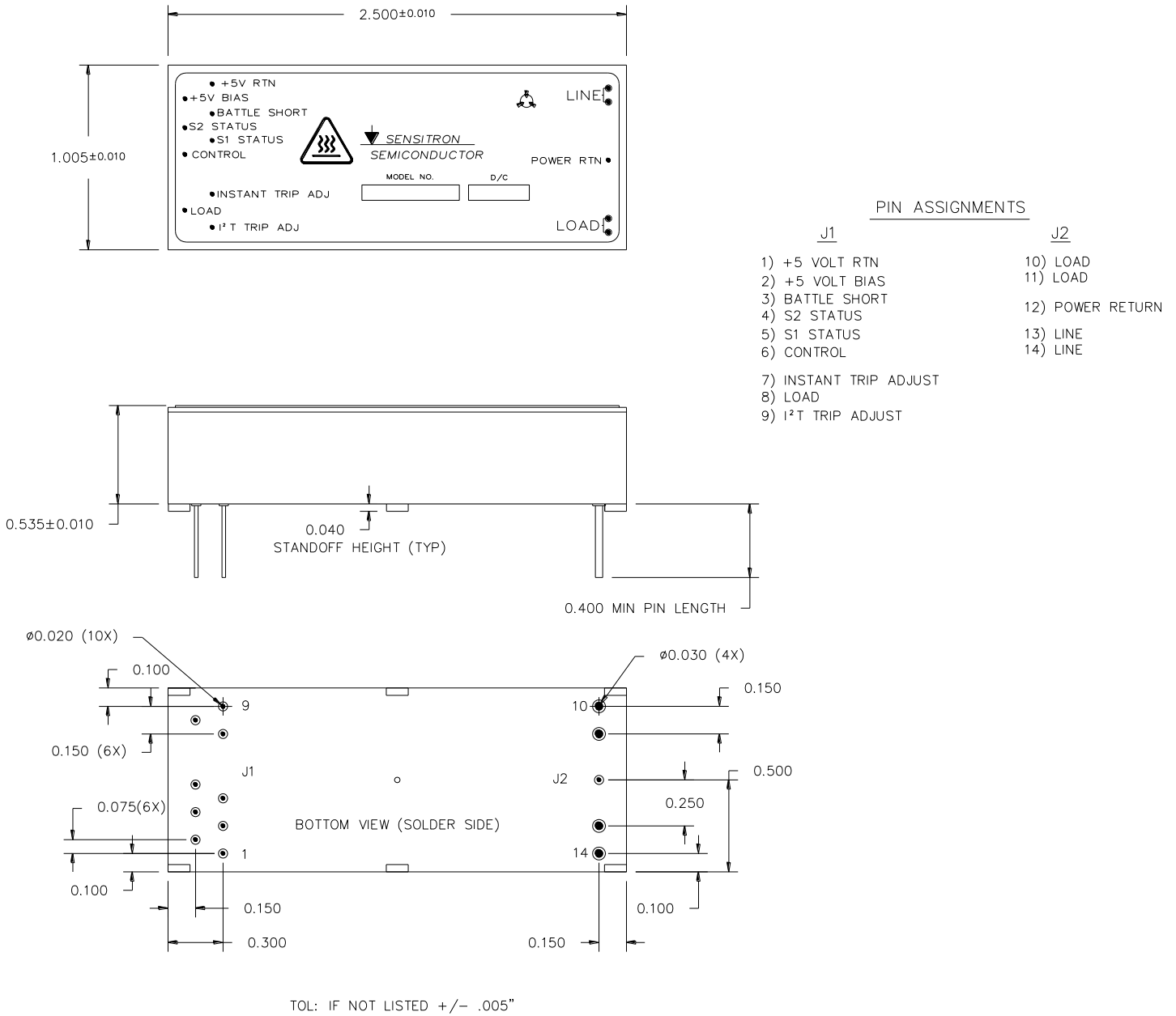

**Figure 2 - Mechanical Dimensions and Pin Assignments**  
All dimensions are in inches

PART NUMBER: SPDP03D270/SPDP03D375  
DATASHEET 5224, Rev. -

**Table 4 – Individual Power Dissipation Data (includes Vbias Power)**

**SPDP03D375**

	<b>SPDP03D375 Set for 0.9 Amp Rating</b>	<b>SPDP03D375 Set for 3 Amp Rating</b>
Current Rating	0.9A	3A
Power Dissipation	0.42W typ @ 0.6A 25°C 0.47W max @ 0.9A 25°C 0.51W max @ 0.9A 100°C	0.56W typ @ 1.8A 25°C 1.2W max @ 3A 25°C 1.90W max @ 3A 100°C
Max Voltage Drop	44mV typ @ 0.6A 25°C 77mV max @ 0.9A 25°C 140mV max @ 0.9A 100°C	100mV typ @ 1.8A 25°C 260mV max @ 3A 25°C 490mV max @ 3A 100°C

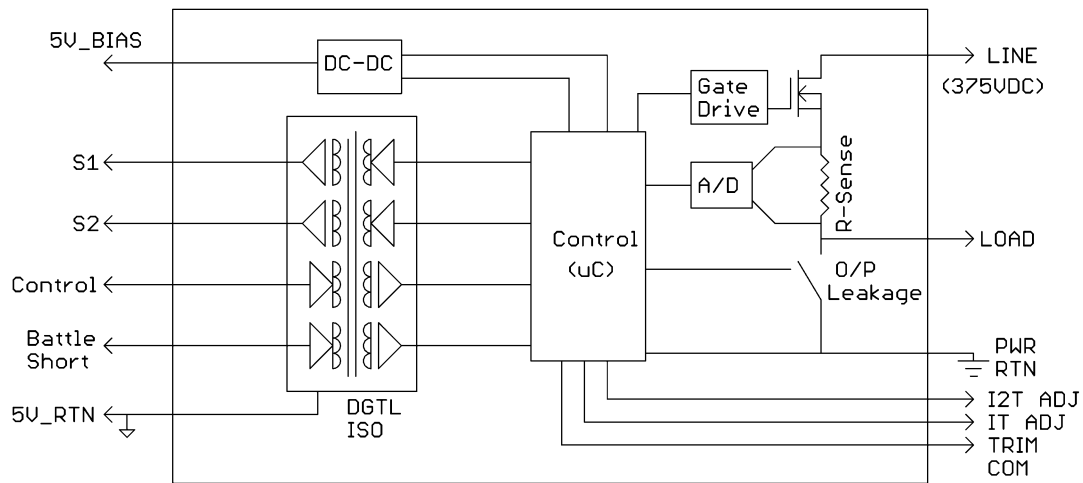

**Figure 3 - Electrical Block Diagram**

**SENSITRON**  
**SEMICONDUCTOR**PART NUMBER: SPDP03D270/SPDP03D375  
DATASHEET 5224, Rev. -**Description**

Figure 3 shows the block diagram of the SPDP03D375 SSPC. It uses a digital isolator for digital I/O. The block labeled "Control ( $\mu\text{C}$ )" gets power from the DC-DC converter and is referenced to the output of the SSPC. This block contains an amplifier to gain up the voltage developed across the sense resistor. It also contains a microcontroller with on-board timers, A/D converter, clock generator and independent watchdog timer. The microcontroller implements a precision  $I^2t$  protection curve as well as an Instant Trip function to protect the wiring and to protect itself. It performs all of the functions of multiple analog comparators and discrete logic in one high-reliability component.

The code programmed in the microcontroller acquires the output of the internal A/D converter, squares the result and applies it to a simulated RC circuit. It checks the output of the simulated circuit to determine whether or not to trip (turn off the power MOSFETs). Because the microcontroller simulates an analog RC circuit, the SSPC has 'thermal memory'. That is, it trips faster if there had been current flowing prior to the overload than if there hadn't been current flowing. This behavior imitates thermal circuit breakers and better protects the application's wiring since the wiring cannot take as much an overload if current had been flowing prior to the overload.

The watchdog timer operates from its own internal clock so a failure of the main clock will not stop the watchdog timer. The code programmed in the microcontroller will periodically reset the watchdog timer preventing it from timing out. If the code malfunctions for any reason, the watchdog timer is not reset and it times out. When the watchdog timer times out, it resets the microcontroller. Since the code is designed to detect levels and not edges, the output of the module, and therefore the output of the SPDPXXD375, immediately reflects the command on its input.

The Control block also has the ability for the user to adjust the current rating by varying the trip point with a resistor between the " $I^2t$  TRIP ADJ" pin and the "LOAD" pin, to adjust the Instant Trip current level with a resistor between the "INSTANT TRIP ADJ" pin and the "LOAD" pin. See Equation (1) to select the appropriate resistor for adjusting the current rating. See Equation 2 to select the appropriate resistor for adjusting the Instant Trip current.

Select  $R_{I2T}$  to program the current rating between 0.9A and 3A. Please notice the actual  $I^2t$  trip level is between 115% and 145% of the programed current according to the  $I^2T$  trip curve.

$$R_{I2T} = 3.24 \cdot 10^3 \cdot \frac{I_0 - I_{I2t\_trip}}{I_{I2t\_trip} - 0.3 \cdot I_0} \cdot \Omega \quad \text{Equation (1)}$$

Select  $R_{INST}$  to program the instant trip level between 400% and 700% of the rated current.

$$R_{INST} = 18.2 \cdot 10^3 \cdot \frac{7 \cdot I_0 - I_{inst\_trip}}{I_{inst\_trip} - 4 \cdot I_0} \cdot \Omega \quad \text{Equation (2)}$$

Note:  $I_0$  is rated current for the SSPC unit 3A.

The Power MOSFETs used in the SPDP03D375 have been selected for very low  $R_{ds(on)}$  and result in low voltage drop and low power dissipation. As can be seen in Table 4, when the SPDP03D375 is operated at 3 Amps, 100% of rated current, it dissipates less than 1.9 Watt in the whole temperature range. When operates at extreme temperature, some heat sink can be accomplished by adding copper area to the "LINE" and "LOAD" pins, a heat sink can be epoxy attached to the surface of the module or a flat copper or



**SENSITRON**  
**SEMICONDUCTOR**

**PART NUMBER: SPDP03D270/SPDP03D375**  
**DATASHEET 5224, Rev. -**

aluminum heat sink can be sandwiched between the SPDP03D375 and the printed circuit board using a thermal pad to maximize heat transfer. Each application should be evaluated at maximum expected constant current.

The SPDP03D375 has sufficient thermal mass that the temperature will rise only a few degrees under the worst-case overload. Repetitive overloads should be avoided. When the SPDPXXD375 reports a trip condition, the controller driving the SPDPXXD375 should allow no more than four repetitions and then allow thirty seconds to cool down before trying to turn on again.

The SPDP03D375 will trip on overloads in the ALWAYS TRIP region and will never trip when in the NEVER TRIP region. It can be reset by bringing the CONTROL pin to a logic low. When the "CONTROL" pin is brought back to logic high, the SPDP03D375 will turn back on. If the overload is still present, it will trip again. Cycling the "5 Volt BIAS" power will also reset the SPDP03D375. If the "CONTROL" pin is at logic high when the "5 Volt BIAS" power is cycled, the SPDP03D375 will turn back on when the "5 Volt BIAS" power is re-applied.

**Status Table**

Table 5 shows the states of the "S1" and "S2" status outputs.

	BS	CONTROL INPUT	OUTPUT	STATUS S1	STATUS S2	SSPC STATUS
1	0	0	OFF	0	0	Normal Off
2	0	0	OFF	0	1	Over Temp
3	0	0	OFF	1	1	No Line Voltage
4	0	1	ON	0	0	Normal On
5	0	1	OFF	0	1	Over Temp
6	0	1	OFF	1	0	Tripped
7	1	X	ON	0	0	Battle short On
8	1	X	ON	0	1	Over Temp observed
9	1	X	ON	1	0	Trip condition observed

**Table 5 – Control and Status**

- **Normal Off** – The SSPC is functioning normally and the channel is off. Both "S1" and "S2" status outputs go to a low level
- **Over Temperature** – An unsafe operating temperature (116°C typical) is detected.
  - a. During normal operation (2, 5), the channel will be turned off. When the temperature drops to about 101°C, the "S2" status output goes back low and the output of the SPDP03D375 is turned back on
  - b. During BS, the condition will only be reported.
- **No Line Voltage** - Both "S1" and "S2" status outputs go to a high level when the line voltage drops below 5 volts or when the load has not been discharged to 5V lower than the line voltage after turn off command. This status has higher priority than over temperature status.
- **Normal On** – The SSPC is functioning normally and the channel is on.
  - a. Tripped – The channel current surpassed the programmed I<sup>2</sup>t/instant trip point of the SPDP03XD375.
  - b. During normal operation the channel will turn off and "S1" will be high and "S2" will be low until reset.
  - c. During BS, and "S1" will be high and "S2" will be low to indicate the condition has been detected.
- **Battleshort On** - The BS mode has priority over all status conditions that would turn off the channel.

**SENSITRON**  
**SEMICONDUCTOR**

PART NUMBER: SPDP03D270/SPDP03D375  
DATASHEET 5224, Rev. -

**High Voltage Considerations**

The SPDP03D375 is designed for 375VDC systems. It contains an Output Leakage Sink to ensure that the output is at a safe voltage when it is off (whether it is turned off or is off due to loss of 5V BIAS Power). This circuitry absorbs the leakage current from the main switch and keeps the output voltage less than 1.5VDC over the temperature range. Figure 3 shows the Output Leakage Sink as a simple switch. However, the Output Leakage Sink is a transistor operating as a current source with a value of 80 mA. When the current into the output leakage sink is less than 80 mA, the transistor saturates and the output leakage sink looks like a resistor of about 60 Ohms. 80 mA can be used to determine how long it takes to discharge a particular load capacitance if the load is a pure capacitance. If the load is a combination of resistance and capacitance, it's likely that the RC time constant will discharge the capacitance faster than the output leakage sink.

Sufficient spacing should be allowed on the user's PCB between the 375VDC line supply and the 375VDC power return and between the CONTROL and 5VDC Bias circuits and the 375VDC circuit to prevent arcing. Due to the small size of the SPDP03D375, the spacing between pins is small so conformal coating should be used to prevent arcing, especially if transient voltages above 375VDC are possible.

**Wire Size**

MIL-W-5088L has a chart that shows wire size as a function of wire temperature and current. This chart is for a single copper wire in free air. For an ambient temperature of 70 °C, the chart allows a 26-gauge wire to handle 3 Amps continuously at a wire temperature of 100 °C – a wire temperature rise of 30°C.

Amendment 1 of MIL-W-5088L has a table for copper wire in a bundle, group or harness with condition on the number of wires, percent of total harness capacity, etc. This table shows that a 22 gauge wire is necessary for 105 °C operation.

MIL-W-5088L has various figures showing derating for harnesses as a function of the number of current carrying conductors for different altitudes. MIL-W-5088L only specifies wire for DC or RMS AC conditions, not for transient or overload conditions. MIL-W-5088L and its amendment should be consulted to determine minimum wire sizes for other currents and conditions.

For transient or overload conditions, the transient or overload happens so quickly that heat is not transferred from the wire to the surroundings. The heat caused by the  $I^2R$  heating of the wire causes the temperature to rise at a linear rate controlled by the heat capacity of the wire. The equation for this linear rise in temperature, with respect to time, can be solved as:  $I^2t = \text{constant}$ . Every wire has an  $I^2t$  rating that's

dependent on the temperature rise allowed and the diameter of the wire. If the  $I^2t$  rating of the SSPC or circuit breaker is less than the  $I^2t$  rating of the wire, then the SSPC or circuit breaker can protect the wire. The maximum  $I^2t$  rating for the SPDP03D375 is 11.7 Amp<sup>2</sup>-Seconds. Every wire size in the paragraphs above has an  $I^2t$  rating that exceeds the SPDP03D375  $I^2t$  rating for the temperature rises stated. Therefore, to select a wire size, it's simply a matter of determining the maximum temperature rise of the application and deciding whether or not the wire will be in a bundle and use the information above.

**Application Connections**

Due to the presence of the circuitry that keeps the output at safe voltage when the SPDP03D375 is off, it may only be configured as a high-side switch as shown in Figure 3.

**Rise Time & Fall Time**

The rise and fall times of the SPDP03D375 are pre-set at the factory for a nominal 2mS rise time and 500µS fall time with a LINE supply of 375VDC (see Table 1 for min/max limits). The rise and fall times will vary

**SENSITRON**  
**SEMICONDUCTOR****PART NUMBER: SPDP03D270/SPDP03D375****DATASHEET 5224, Rev. -**

linearly with supply voltage. The "PWR RTN" pin is used to control the rise and fall times. If the "PWR RTN" pin is left open, the rise time will be around 400 $\mu$ S, and the fall time will be around 50 $\mu$ S (control to gate change delay will stay the same). Leaving the "PWR RTN" pin open can be useful when a faster rise or fall time is desirable; however, the Output Leakage Sink will not be functional with the "PWR RTN" pin open. And fault may be tripped by capacitive load.

With the "PWR RTN" pin connected as in Figures 3, the SPDP03D375, when set for a 3 Amp rating, can turn on into a capacitive load of 40 $\mu$ F, typ. without tripping for any power supply voltage within the rating.

**Short circuit definition**

With the "PWR RTN" pin connected as in Figures 3, SPDPxxD375 can survive at short circuit condition which has been defined by 0.1Ohm resistor in series with 1.35uH inductance across the LOAD and LOAD\_RTN. At 25 °C, short circuit trip level has been defined as current larger than 21.2A (typical). And this short circuit trip level will decrease with temperature linearly at a rate of 0.1A/°C (typical). So the unit will trip at lower current level when at higher temperature to protect itself, which means at high temperature, short circuit trip level may be lower than the set instant trip level.

**Wiring and Load Inductance**

Wiring inductance can cause voltage transients when the SPDP03D375 is switched off due to an overload. Generally, these transients are small but must be considered when long wires are used on either the "LINE" or "LOAD" pins or both. A 30 foot length of wire in free air will cause a transient voltage of about 10 Volts when the SPDP03D375 trips at an Instant Trip level of 21 Amps. At the rated load current of 3 Amps, the voltage transient will be less than 1 Volt. A transient suppressor is recommended at the "LINE" pin so that the total voltage between the "LINE" and "LOAD" pins is less than 500 Volts. The SPDP03D375V unit includes a reverse biased diode from the "LOAD" to "PWR RTN" pins to prevent damaging transients on the output due to inductive loads.

**Paralleling**

For example, putting two SPDP03D375s in parallel will not double the rating to 6 Amps. Due to differences in the Rds (on) of the Power Mosfets in the SSPCs, the current will not share equally. In addition, there are unit-to-unit differences in the trip curves so that two SPDP03D375s in parallel may possibly trip at 5 Amps. Also, both SPDP03D375s will not trip together; the SPDP03D375 carrying the higher current will trip first followed by the other SPDP03D375. Multiple units may be used in parallel as long as these complexities are appreciated.

**Board Layout**

The current-carrying power circuit should be kept well away from the control circuit and other low-level circuits in the system. It's unlikely, but possible, that magnetic coupling could affect the control circuit when turning normal loads on and off. However, in the case of an overload, the magnetic coupling could be 10 times greater than with normal loads. Effects of such coupling could cause 'chattering' when turning on and off, oscillation, and the possibility of turning the SPDP03D375 back on after an overload. The SPDP03D375 is a Trip-Free device. Once tripped it will not turn back on until reset and commanded on again. Reset is accomplished by bringing the "CONTROL" pin low and then turning the SSPC back on by bringing the "CONTROL" pin high. Sufficient magnetic coupling between the current-carrying power circuit and the control circuit can negate the Trip-Free characteristic.

**MIL-STD-704F**

This standard covers the characteristics of the electrical systems in Military Aircraft. The SPDP03D375 meets all of the requirements of MIL-STD-704F including Normal, Emergency, Abnormal and Electric Starting conditions with the Ripple, Distortion Factor and Distortion Spectrum defined in the standard. In addition, the SPDP03D375 can withstand + 600 V spikes for 10 $\mu$ S. This capability is beyond that required by MIL-STD-704F.

**SENSITRON**  
**SEMICONDUCTOR**

**PART NUMBER: SPDP03D270/SPDP03D375**  
**DATASHEET 5224, Rev. -**

**DISCLAIMER:**

1- *The information given herein, including the specifications and dimensions, is subject to change without prior notice to improve product characteristics. Before ordering, purchasers are advised to contact the Sensitron Semiconductor sales department for the latest version of the datasheet(s).*

2- *In cases where extremely high reliability is required (such as use in nuclear power control, aerospace and aviation, traffic equipment, medical equipment, and safety equipment), safety should be ensured by using semiconductor devices that feature assured safety or by means of users' fail-safe precautions or other arrangement.*

3- *In no event shall Sensitron Semiconductor be liable for any damages that may result from an accident or any other cause during operation of the user's units according to the datasheet(s). Sensitron Semiconductor assumes no responsibility for any intellectual property claims or any other problems that may result from applications of information, products or circuits described in the datasheets.*

4- *In no event shall Sensitron Semiconductor be liable for any failure in a semiconductor device or any secondary damage resulting from use at a value exceeding the absolute maximum rating.*

5- *No license is granted by the datasheet(s) under any patents or other rights of any third party or Sensitron Semiconductor.*

6- *The datasheet(s) may not be reproduced or duplicated, in any form, in whole or part, without the expressed written permission of Sensitron Semiconductor.*

7- *The products (technologies) described in the datasheet(s) are not to be provided to any party whose purpose in their application will hinder maintenance of international peace and safety nor are they to be applied to that purpose by their direct purchasers or any third party. When exporting these products (technologies), the necessary procedures are to be taken in accordance with related laws and regulations.*