

# MC1711 MC1711C



**MOTOROLA**

## DUAL DIFFERENTIAL VOLTAGE COMPARATOR

... designed for use in level detection, low-level sensing, and memory applications.

Typical Characteristics:

- Differential Input  
Input Offset Voltage = 1.0 mV  
Offset Voltage Drift = 5.0  $\mu\text{V}/^\circ\text{C}$
- Fast Response Time – 40 ns
- Output Compatible with All Saturating Logic Forms  
 $V_{\text{out}} = +4.5 \text{ V}$  to  $-0.5 \text{ V}$  typical
- Low Output Impedance – 200 ohms

## DUAL DIFFERENTIAL COMPARATOR

**SILICON MONOLITHIC  
INTEGRATED CIRCUIT**

### MAXIMUM RATINGS ( $T_A = +25^\circ\text{C}$ unless otherwise noted.)

Rating	Symbol	Value	Unit
Power Supply Voltage	$V_{CC}$ $V_{EE}$	+14 -7.0	Vdc
Differential Input Signal Voltage	$V_{IDR}$	$\pm 5.0$	Volts
Common-Mode Input Swing Voltage	$V_{ICR}$	$\pm 7.0$	Volts
Peak Load Current	$I_L$	50	mA
Power Dissipation (package limitation)	$P_D$	680	mW
Metal Package Derate above $T_A = +25^\circ\text{C}$		4.6	mW/ $^\circ\text{C}$
Ceramic and Plastic Dual In-Line Packages Derate above $T_A = +25^\circ\text{C}$		5.0	mW/ $^\circ\text{C}$
Operating Temperature Range	MC1711 MC1711C	$T_A$ -55 to +125 0 to +75	$^\circ\text{C}$
Storage Temperature Range		$T_{stg}$ -65 to +150	$^\circ\text{C}$

8

**G SUFFIX  
METAL PACKAGE  
CASE 603-04  
TO-100**

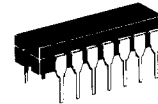
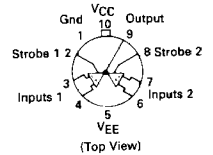

**L SUFFIX  
CERAMIC PACKAGE  
CASE 632-02  
MO-001AA**

**P SUFFIX  
PLASTIC PACKAGE  
CASE 646-05  
(MC1711C only)**

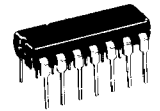

### CIRCUIT SCHEMATIC

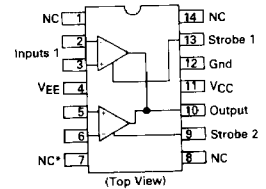
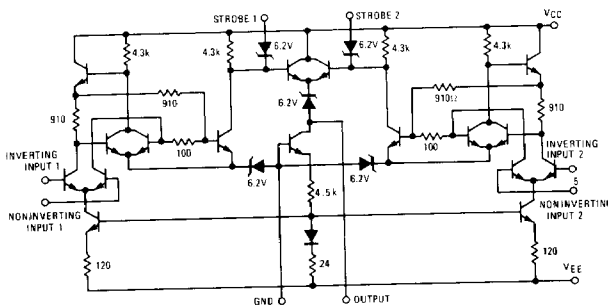

# MC1711, MC1711C

**ELECTRICAL CHARACTERISTICS** (each comparator) ( $V_{CC} = +12$  Vdc,  $V_{EE} = -6.0$  Vdc,  $T_A = +25^\circ\text{C}$  unless otherwise noted.)

Characteristic	Symbol	MC1711			MC1711C			Unit
		Min	Typ	Max	Min	Typ	Max	
Input Offset Voltage ( $V_{ICR} = 0$ Vdc, $T_A = +25^\circ\text{C}$ ) ( $V_{ICR} \neq 0$ Vdc, $T_A = +25^\circ\text{C}$ ) ( $V_{ICR} = 0$ Vdc, $T_A = T_{low}$ to $T_{high}^*$ ) ( $V_{ICR} \neq 0$ Vdc, $T_A = T_{low}$ to $T_{high}^*$ )	$V_{IO}$	—	1.0	3.5	—	1.0	5.0	mVdc
Temperature Coefficient of Input Offset Voltage	$\Delta V_{IO}/\Delta T$	—	5.0	—	—	5.0	—	$\mu\text{V}/^\circ\text{C}$
Input Offset Current ( $V_O = 1.4$ Vdc, $T_A = +25^\circ\text{C}$ ) ( $V_O = 1.8$ Vdc, $T_A = -55^\circ\text{C}$ ) ( $V_O = 1.5$ Vdc, $T_A = 0^\circ\text{C}$ ) ( $V_O = 1.0$ Vdc, $T_A = +125^\circ\text{C}$ ) ( $V_O = 1.2$ Vdc, $T_A = +75^\circ\text{C}$ )	$I_{IO}$	—	0.5	10	—	0.5	15	$\mu\text{Adc}$
Input Bias Current ( $V_O = 1.4$ Vdc, $T_A = +25^\circ\text{C}$ ) ( $V_O = 1.8$ Vdc, $T_A = -55^\circ\text{C}$ ) ( $V_O = 1.5$ Vdc, $T_A = 0^\circ\text{C}$ ) ( $V_O = 1.0$ Vdc, $T_A = +125^\circ\text{C}$ ) ( $V_O = 1.2$ Vdc, $T_A = +75^\circ\text{C}$ )	$I_{IB}$	—	25	75	—	25	100	$\mu\text{Adc}$
Voltage Gain ( $T_A = +25^\circ\text{C}$ ) ( $T_A = T_{low}$ to $T_{high}$ )	$A_{vol}$	700 500	1500	—	700 500	1500	—	V/V
Output Resistance	$R_O$	—	200	—	—	200	—	ohms
Differential Voltage Range	$V_{IDR}$	$\pm 5.0$	—	—	$\pm 5.0$	—	—	Vdc
High Level Output Voltage ( $V_{ID} \geq 10$ mVdc, $0 \leq I_O \leq 5.0$ mA)	$V_{OH}$	2.5	3.2	5.0	2.5	3.2	5.0	Vdc
Low Level Output Voltage ( $V_{ID} \geq -10$ mVdc)	$V_{OL}$	-1.0	-0.5	0	-1.0	-0.5	0	Vdc
Strobed Output Level ( $V_{strobe} \leq 0.3$ Vdc)	$V_{OL(st)}$	-1.0	—	0	-1.0	—	0	Vdc
Output Sink Current ( $V_{in} \geq -10$ mV, $V_O \geq 0$ )	$I_{Os}$	0.5	0.8	—	0.5	0.8	—	mAdc
Strobe Current ( $V_{strobe} = 100$ mVdc)	$I_{st}$	—	1.2	2.5	—	1.2	2.5	mAdc
Input Common-Mode Range ( $V_{EE} = -7.0$ Vdc)	$V_{ICR}$	$\pm 5.0$	—	—	$\pm 5.0$	—	—	Volts
Response Time ( $V_b = 5.0$ mV + $V_{IO}$ )	$t_R$	—	40	—	—	40	—	ns
Strobe Release Time	$t_{SR}$	—	12	—	—	12	—	ns
Power Supply Current ( $V_O \leq 0$ Vdc)	$I_{CC}$ $I_{EE}$	—	8.6 3.9	—	—	8.6 3.9	—	mAdc
Power Consumption		—	130	200	—	130	200	mW

\* $T_{low} = -55^\circ\text{C}$  for MC1711,  $0^\circ\text{C}$  for MC1711C  
 $T_{high} = +125^\circ\text{C}$  for MC1711,  $+75^\circ\text{C}$  for MC1711C

TYPICAL CHARACTERISTICS

FIGURE 1 – VOLTAGE TRANSFER CHARACTERISTICS

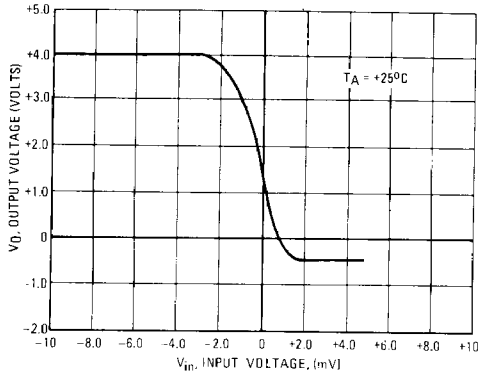

FIGURE 2 – INPUT BIAS CURRENT versus TEMPERATURE

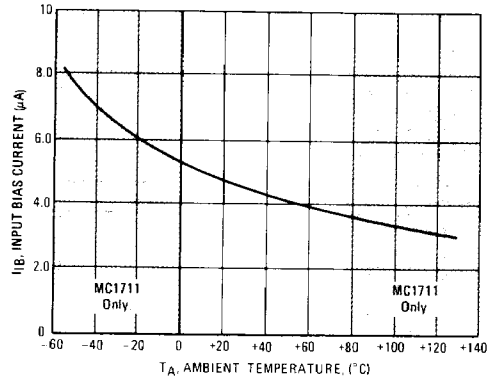

FIGURE 3 – VOLTAGE GAIN versus TEMPERATURE

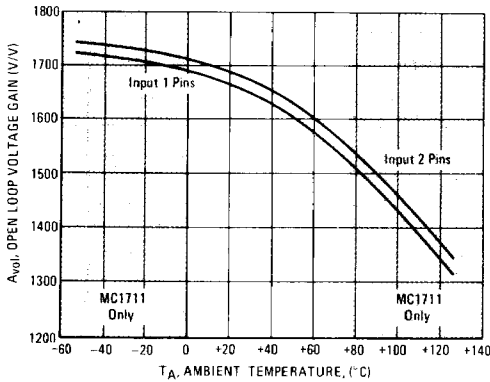

FIGURE 4 – RESPONSE TIME FOR VARIOUS INPUT OVERDRIVES

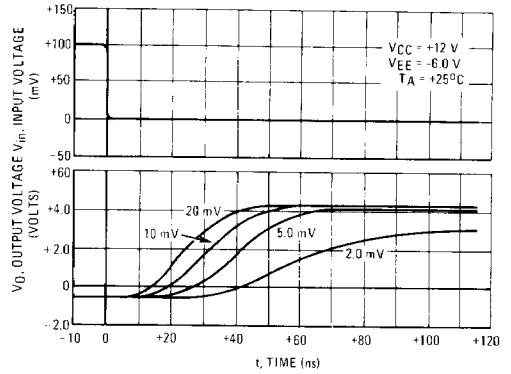

FIGURE 5 – VOLTAGE GAIN VARIATION WITH POWER SUPPLY VOLTAGE

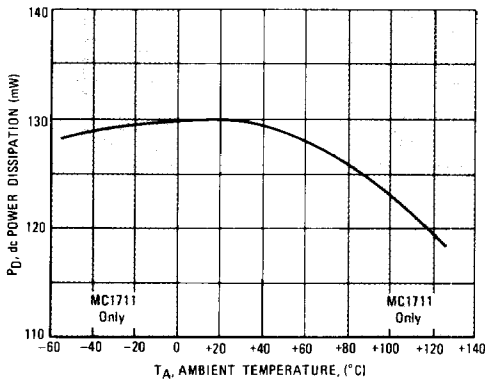
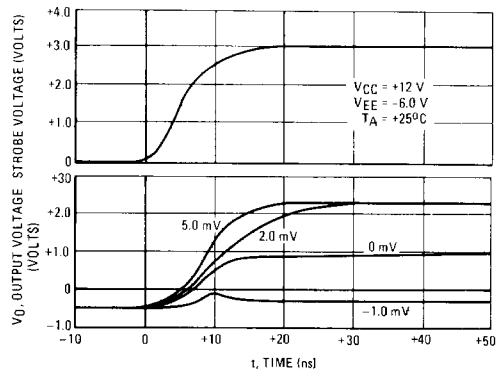

FIGURE 6 – STROBE RELEASE TIME FOR VARIOUS INPUT OVERDRIVES



8

FIGURE 7 – COMMON-MODE PULSE RESPONSE

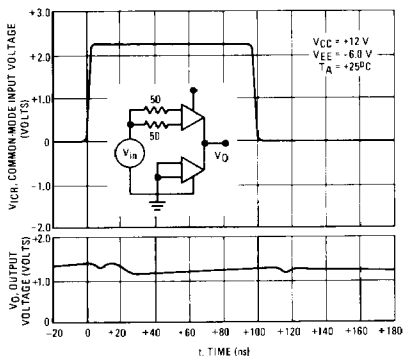

FIGURE 8 – OUTPUT PULSE STRETCHING WITH CAPACITIVE LOADING

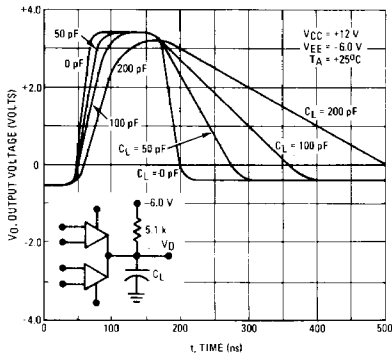

FIGURE 9 – RECOMMENDED SERIES RESISTANCE versus MRTL LOADS

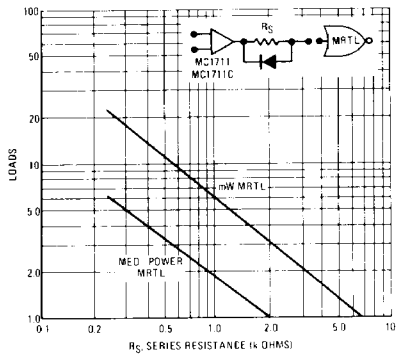

FIGURE 10 – FAN-OUT CAPABILITY WITH MDTL OR MTTL OUTPUT SWING

