



2Mx32 FLASH MODULE

FEATURES

- 2Mx32 and 2x2Mx32 Densities
- Based on AMD - AM29LV017B Flash Device
- Fast Read Access Time - 90ns
- 3.3V-Only Reprogramming
- Sector Erase Architecture
 - Uniform sectors of 64 Kbytes each
 - Any combination of sectors can be erased
 - Supports full chip erase
- Sector Protection
 - Hardware method that disables any combination of sector from write or erase operations
- Embedded Erase Algorithms
 - Automatically preprograms and erases the chip or any combination of sectors
- Embedded Program Algorithms
 - Automatically programs and verifies data at specified address

- Data Polling and Toggle Bit feature for detection of program or erase cycle completion
- Low Power Dissipation
 - 30mA per Device Active Write Current
 - 5µA per Device CMOS Standby Current
- Typical Endurance >100,000 Cycles
- Single 3.0V ±10% Supply
- CMOS and TTL Compatible Inputs and Outputs
- Commercial and Industrial Temperature Range
- Package
 - 80 Pin SIMM (JEDEC)

DESCRIPTION

The EDI7F332MV and EDI7F2332MV are organized as one and two banks of 2Mx32 respectively. The modules are based on AMDs AM29LV017B- 2Mx8 Flash device in TSOP packages which are mounted on an FR4 substrate.

Both modules offer access times between 90 and 120ns allowing for operation of high-speed microprocessors without wait states.

FIG. 1 BLOCK DIAGRAMS

EDI7F332MV-BNC: 2Mx32, 80 PIN SIMM

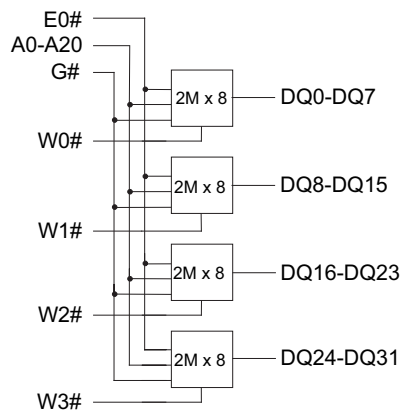

EDI7F2332MV-BNC: 2x2Mx32, 80 PIN SIMM

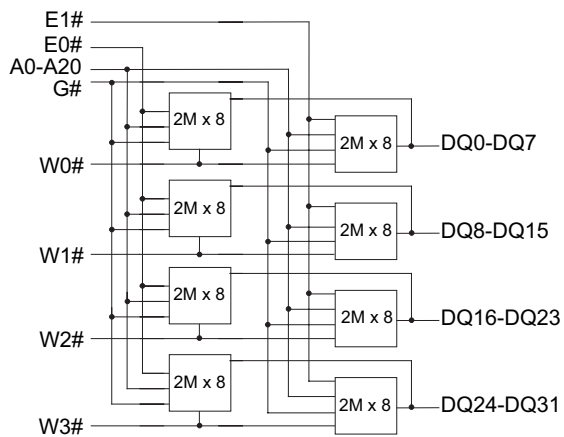

White Electronic Designs Corp. reserves the right to change products or specifications without notice.



CAPACITANCE

(F=1.0MHz, VIN = VCC OR VSS)

Parameter	Sym	2M	2x2M	Unit
		Max	Max	
Address Lines	CA	35	70	pF
Data lines	CDQ	15	30	pF
Chip Enable Lines	CE	40	40	pF
Write Enable Lines	CW	20	20	pF
Output Enable lines	CG	40	80	pF

PIN CONFIGURATIONS

Pin #	Pin Name	Pin #	Pin Name	Pin #	Pin Name	Pin #	Pin Name
1	Vss	21	*	41	A11	61	DQ9
2	Vcc	22	*	42	A10	62	DQ8
3	NC	23	*	43	A9	63	DQ7
4	G#	24	*	44	A8	64	DQ6
5	W0#	25	Vss	45	A7	65	DQ5
6	W1#	26	DQ29	46	A6	66	DQ4
7	NC	27	DQ30	47	A5	67	DQ3
8	DQ16	28	DQ31	48	A4	68	DQ2
9	DQ17	29	W2#	49	A3	69	DQ1
10	DQ18	30	NC	50	A2	70	DQ0
11	DQ19	31	NC	51	A1	71	NC
12	DQ20	32	A20	52	AO	72	Vcc
13	DQ21	33	A19	53	W3#	73	PD1
14	DQ22	34	A18	54	Vss	74	PD2
15	DQ23	35	A17	55	DQ15	75	PD3
16	DQ24	36	A16	56	DQ14	76	PD4
17	DQ25	37	A15	57	DQ13	77	PD5
18	DQ26	38	A14	58	DQ12	78	PD6
19	DQ27	39	A13	59	DQ11	79	PD7
20	DQ28	40	A12	60	DQ10	80	Vss

*TBD

SIMM DENSITY

Pin	2M	2x2M
21	NC	NC
22	NC	NC
23	NC	E1#
24	E0#	E0#

PRESENCE DETECT PIN OUT

Pin	2M	2x2M
PD1	Vss	NC
PD2	NC	Vss
PD3	Vss	Vss
PD4	Vss	Vss

A0-A20	Address input
E0#,E1#	Chip Enable
W0#-W3#	Write Enable
G#	Output Enable
DQ0-DQ31	Data Input/Output
PD	Presence Detect
Vcc	Power 3V±10%
Vss	Ground
NC	No Connect



ORDERING INFORMATION

Part Number	Speed (ns)	Package
EDI7F332MV90BNC	90	369
EDI7F332MV100BNC	100	369
EDI7F332MV120BNC	120	369

Note: To order an Industrial grade product substitute the letter C in the Suffix with the letter I.

PACKAGE NO. 369: 80 PIN SIMM (JEDEC)

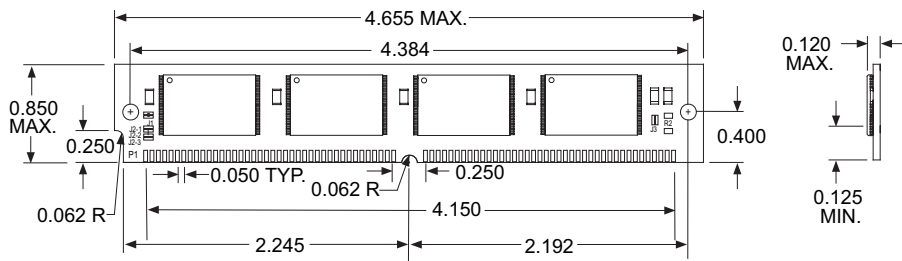

ORDERING INFORMATION

Part Number	Speed (ns)	Package
EDI7F2332MV90BNC	90	370
EDI7F2332MV100BNC	100	370
EDI7F2332MV120BNC	120	370

Note: To order an Industrial grade product substitute the letter C in the Suffix with the letter I.

PACKAGE NO. 370: 80 PIN SIMM (JEDEC)

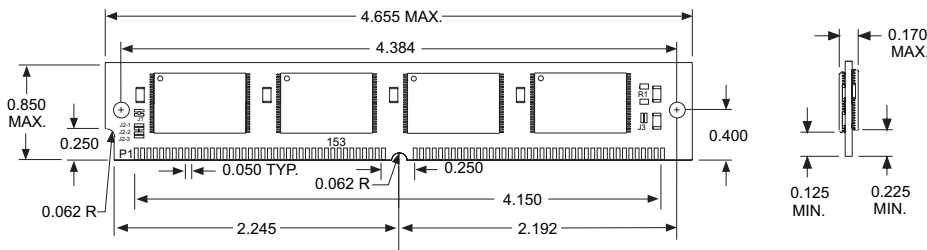

ALL DIMENSIONS ARE IN INCHES