

Charge Timer

Description

The U2403B is a monolithic, integrated-bipolar circuit which can be used in applications for time-controlled, constant-current charge. Selection of charge current versus timing is carried out by using the external circuit at Pins 2, 3 and 4. For high current requirement, an external transistor is recommended in series with the battery. To protect the IC against high power loss

(typically $> 140^{\circ}\text{C}$), the oscillator is shut down when the reference voltage is switched off (0 V). The latter also takes place when there is a saturation caused by collector voltage at Pin 1. When the overtemperature has disappeared and the collector voltage at Pin 1 has exceeded the supply voltage ($V_1 > V_S$), charge time operation continues (see flow chart in figure 4).

Features

- Easy-to-run autonomous dual rate charger
- Constant charge current
- 3 h – 24 h charge time programmable
- Low-cost DC regulator
- Overtemperature protection
- Charge-mode indication
- Operation starts at the moment of battery insertion
- Fast charge-time test mode

Applications

- Cordless telephones
- Low-cost battery-charge timer
- Entertainment

Block Diagram

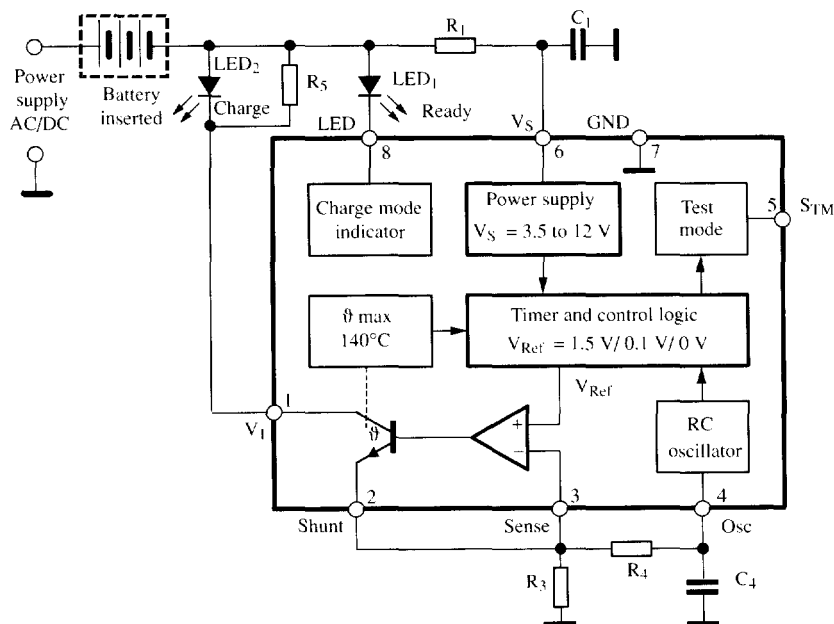

Figure 1. Block diagram with external circuit

Ordering Information

Extended Type Number	Package	Remarks
U2403B-x	DIP8	Tube
U2403B-xFP	SO8	Tube
U2403B-xFPG3	SO8	Taped and reeled

Pin Description

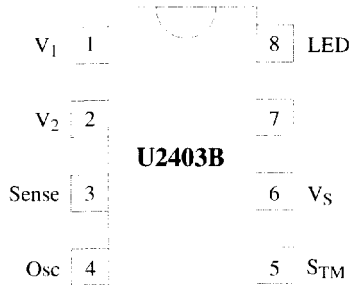

Figure 2. Pinning

Pin	Symbol	Function
1	V ₁	Collector terminal
2	V ₂	Shunt emitter terminal
3	V ₃	Amplifier sense input
4	Osc	Oscillator input
5	S _{TM}	Test mode switch
6	V _S	Supply voltage
7	GND	Reference point, GND
8	LED	Charge mode indicator

Pin 1, Collector Voltage V₁

Pin 1 is an open collector output. When $V_1 \leq 3$ V, the charge cycle is switched off until it is above the supply voltage, as shown in figure 6.

Pin 2, Shunt Emitter

The constant current source is supplied by the internal operational amplifier. The voltage across R₃ is determined via the internal reference source.

$$I_{ch} = V_3/R_3 \quad (V_3 = V_{sense})$$

Pin 3, Amplifier Sense Input (Inverted)

The voltage-regulated current source has a closed loop at Pin 2, Pin 3, and resistor R₃.

Pin 4, Oscillator Input R₄, C₄

Selection of current charge versus timing is carried out by using the external circuit at Pins 2, 3, and 4. Typical values are given in charge characteristics (see table next page).

Pin 5, Test-Mode Switch for Charging Time

The charging time, t_{ch} , is given by the following equation.

$$t_{ch} = \frac{1}{f_{osc}} \times 2^n$$

where:

$$f_{osc} = \text{oscillator frequency (see figure 3)}$$

- n = frequency divider
- = 26, if S_{TM} open
- = 17, if S_{TM} = GND
- = 8, if S_{TM} = V_S

The first eight divider stages can be tested directly. 256 input tact signals at Pin 4 create one tact signal at Pin 5.

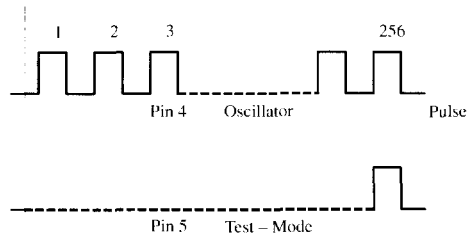

Figure 3. Quick test timer 1/3

Example

Assume a charge time of 6 h. Select the values of R₄ and C₄ from the tables next page.

For example: R₄ = 470 kΩ
C₄ = 680 pF

There is a frequency of approximately 3100 Hz at Pin 4. It is possible to test the charge time of 6 h by running through the charge cycle for a very short time. By connecting Pin 5 with GND, the test time is 42 s. By connecting Pin 5 with Pin 1 (V₁), the test time is reduced to about 82.4 ms. R₅ is connected in parallel to the LED₂ and provides a protective bypass function for the LED (see figure 1).

Pin 6, Supply Voltage, V_S

- $V_S \approx 3.1\text{ V}$ power-on reset release (turn-on)
- $V_S \approx 2.9\text{ V}$ under-voltage reset
- $V_S \approx 13\text{ V}$ supply voltage limitation

Pin 7, Ground

Pin 8, Charge Mode Indicator

An open-collector output supplies constant current to LED₁ after the active charge phase has been terminated. $\dot{\theta}_{\max}$ controls the function temperature for the final stage range. This is when the temperature is above 140°C and the charge function is therefore switched off.

Trickle Charge

The trickle charge starts after the charge has been terminated. In this case, the internal reference voltage is reduced from 1.5 V to approximately 0.1 V. This means the charge current is decreased by the factor:

$$K = 1.5\text{ V} / 0.1\text{ V} = 15.$$

$$\text{Trickle current} = I_{\text{ch}} / 15 + I_6 \text{ (supply current)} + I_8$$

It is possible to reduce the trickle charge with resistor R₆, as shown in figures 7 and 8.

Charge Characteristics

Charge Time

Test Time/ Test-Mode Switch S_{TM}			Oscillator Components		Frequency
Open	V_S	GND	R ₄ (k Ω)	C ₄ (pF)	f_{osc} (Hz)
3 h	41.2 ms	21 s	510	270	6213
			430	330	
			300	470	
4 h	54.9 ms	28 s	620	330	4660
			430	470	
			300	680	
5 h	68.6 ms	35 s	510	470	3728
			390	680	
			300	1000	
6 h	82.4 ms	42 s	620	470	3105
			470	680	
			360	1000	
7 h	96.1 ms	49 s	560	680	2663
			430	1000	
			220	2200	
8 h	109.8 ms	56 s	620	680	2330
			470	1000	
			200	2200	
9 h	123.6 ms	1 min 3 s	750	680	2071
			510	1000	
			240	2200	
10 h	137.3 ms	1 min 10 s	620	820	1864
			270	2200	
			130	4700	
12 h	164.8 ms	1 min 24 s	390	2200	1553
			150	4700	
16 h	219.7 ms	1 min 56 s	470	2200	1165
			200	4700	

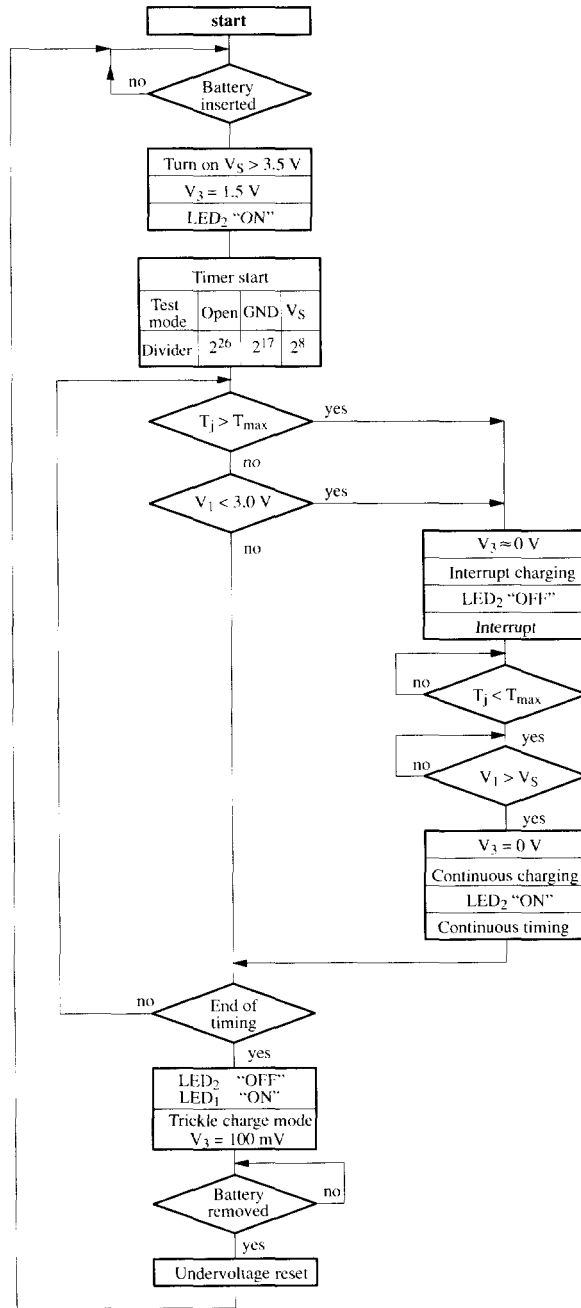

Figure 4. Flow chart

Absolute Maximum Ratings

Reference point Pin 7 (GND), unless otherwise specified.

Parameters		Symbol	Value	Unit
Supply current	Pin 6	I_S	20	mA
		i_s	100	mA
Currents	Pin 1	I_1	300	mA
	Pin 2	$-I_2$	310	mA
	Pin 3	I_3	1	μ A
	Pin 4	I_4	15	mA
	Pin 5	I_5	-75 to +120	μ A
	Pin 8	I_8	8	mA
Voltages	Pins 1, 3, 5, 6 and 8	V	13.5	V
	Pin 2	V_2	1.6	V
	Pin 4	V_4	1.5	V
Junction temperature		T_j	150	$^{\circ}$ C
Ambient temperature		T_{amb}	-10 to 85	$^{\circ}$ C
Storage temperature range		T_{stg}	-50 to +150	$^{\circ}$ C

Thermal Resistance

Parameters		Symbol	Value	Unit
Junction ambient				
	DIP8	R_{thJA}	120	K/W
	SO8 on PC-board	R_{thJA}	220	K/W
	SO8 on ceramic	R_{thJA}	140	K/W
	SO8 on ceramic with thermal compound	R_{thJA}	80	K/W

Electrical Characteristics

$V_S = 6\text{ V}$, $T_{\text{amb}} = 25^\circ\text{C}$, reference point Pin 7 (GND), unless otherwise specified.

Parameters	Test Conditions / Pins	Symbol	Min.	Typ.	Max.	Unit
Supply voltage limitation	$I_S = 4\text{ mA}$ Pin 6	V_S	12.5		13.5	V
	$I_S = 20\text{ mA}$ Pin 6	V_S	12.6		13.7	V
Supply current	$V_S = 6\text{ V}$	I_S	1.4		2.2	mA
Voltage monitoring		Pin 6				
Turn-on threshold		V_{TON}	2.8		3.5	V
Turn-off threshold		V_{TOFF}	2.5		3.2	V
Charge-mode indicator (LED)		Pin 8				
LED current		I_8	3.0		6.0	mA
LED saturation voltage	$I_8 = 3.7\text{ mA}$	V_8			960	mV
Leakage current		I_{lk}	-0.35		1.1	μA
Collector terminal, figure 6		Pin 1				
Open collector current		I_{CO}	15		55	μA
Saturation threshold	$V_S = 6\text{ V}$	V_{TON}	2.55	3.0	3.35	V
		V_{TOFF}	$V_S - 1\text{ V}$	V_S	$V_S - 0.4\text{ V}$	V
Shunt emitter current	$R_3 = 5.6\ \Omega$ Pin 2	I_2	250		285	mA
Operational sense amplifier, figure 1		Pin 3				
Input current	$V_3 = 0\text{ V}$	I_3	-0.6		0.08	μA
Input voltage	$V_{\text{Ref}} = 1.5\text{ V}$	V_3	1.42	1.5	1.58	V
	$V_{\text{Ref}} = 100\text{ mV}$	V_3	40	70	100	mV
	$V_{\text{Ref}} = 0\text{ V}$	V_3	-0.4		40	mV
Oscillator		Pin 4				
Leakage current	$V_4 = 0\text{ to }0.85\text{ V}$	I_{lk}	-0.5		0.1	μA
Threshold voltage	Upper	$V_{\text{T(u)}}$	875		985	mV
Oscillator frequency	$R_4 = 160\text{ k}\Omega$, $C_4 = 2.2\text{ nF}$	f_{osc}	2700		3050	Hz
	$R_4 = 680\text{ k}\Omega$, $C_4 = 4.7\text{ nF}$	f_{osc}	305		345	Hz
Test mode switch (S_{TM})		Pin 5				
Input current	$V_5 = 6\text{ V}$	I_5	40		120	μA
	$V_5 = 0\text{ V}$	I_5	-75		-20	μA
Output voltage	High	$V_{0(\text{H})}$	1.7		2.5	V
	Low	$V_{0(\text{L})}$	0.5		1.0	V

Internal Temperature Switch

The internal temperature monitoring is active if the chip temperature rises above 140°C. Above this temperature the voltage at Pin 3 goes to zero. Similarly, the charge current, I_{ch} , reduces according to the equation:

$$I_{ch} = V_3 / R_3$$

where $I_{ch} = 1$ to 2 mA (IC supply current)

The oscillator is connected to GND via Pin 3 (V_3) which holds the present time status. When the chip temperature decreases below the transition value, all functions are released and the charge time is continued. The process is reversible. If there is a higher power dissipation in the circuit ($T_j > 140^\circ\text{C}$), the temperature monitoring remains permanently activated (ON). The total cycle time is prolonged according to the interrupt-time duration, see figure 5.

Automatic Control Protection

To reduce the design costs, it is possible to select the transformer which requires minimum power supply.

The output stage of the control is selected so that it is switched off before saturation is achieved ($V_{CEsat} = 3.0\text{ V}$). In this case, the voltage at Pin 3 is kept at a value of zero. The charge current is also zero and the transformer is now an open circuit impedance. The system becomes active again if $V_1 \geq V_S$.

The advantage of the system is that if sags of short duration appear on the mains voltage or if the transformers used are too small, the charge duration is increased, but the charge capacity remains the same, see figure 6.

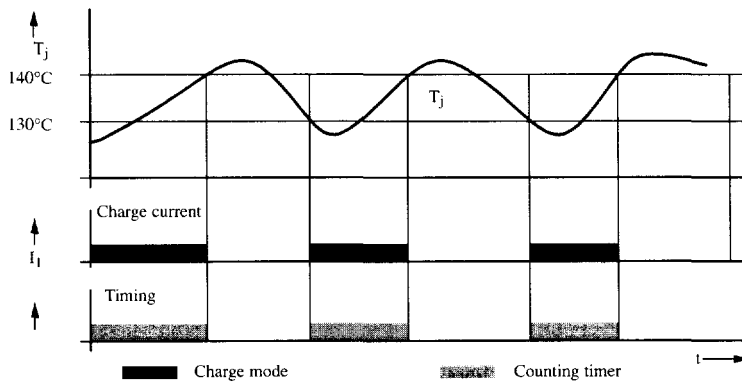

Figure 5. Charge duration – overtemperature

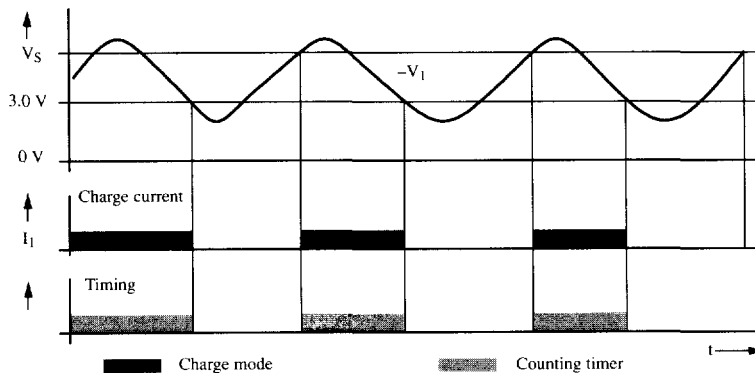

Figure 6. Charge duration – V_1

Standard Applications

Basic Example

NiCd battery 750 mAh	$R_1 = 510 \Omega, 1/8 \text{ W}$
Charging time: 3 h	$C_1 = 47 \mu\text{F}/16 \text{ V}$
Charge current: 240 mA, 1/3 C	$R_3 = 6.2 \Omega, 1/2 \text{ W}$
Trickle charge: 19 mA < 1/40 C	$R_4 = 300 \text{ k}\Omega$
	$C_4 = 470 \text{ pF}$
	$R_5 = 8.2 \Omega, 1/2 \text{ W}$

Minimum Supply Voltage

No of Cells	DC Supply Minimum
1	6.8 V
2	8.3 V
3	9.8 V
4	11.3 V
5	12.8 V

Special Requirements of Different Charge Times

R_4, C_4 values for different charging times

	2 h	4 h	6 h	7 h	12 h
R_4	300 k Ω	430 k Ω	470 k Ω	470 k Ω	390 k Ω
C_4	330 pF	470 pF	680 pF	1 nF	2.2 nF

Special Requirements for Different Charge Current

R_3, R_5 values for different charge current

	240 mA	150 mA	100 mA	50 mA
R_3	6.2 Ω	10 Ω	15 Ω	30 Ω
R_5	8.2 Ω	15 Ω	22 Ω	68 Ω

Basic Equations

$$R_1 = 0.5 \text{ V} / I_S$$

$$I_S = 1.8 \text{ mA}$$

$$R_5 = V_5 / (I_{ch} - 20 \text{ mA})$$

Nominal Charge Current:

$$I_{ch} = V_3 / R_3 \text{ where } V_3 = 1.48 \text{ V (typ.)}$$

Trickle Current:

$$I_{ch} = V_3 / R_3 + I_8 + I_S$$

Typical values are:

$$V_3 = 100 \text{ mV}, I_8 = 4.5 \text{ mA}$$

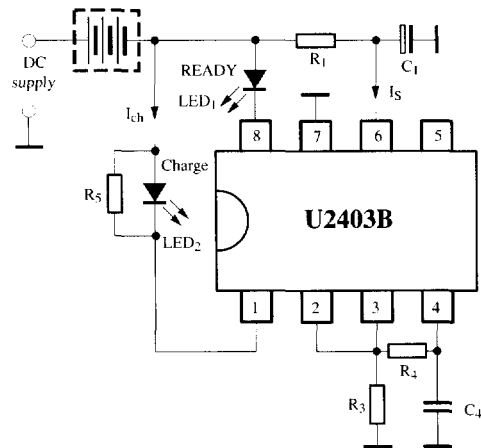

Figure 7. Standard application

Charge System at Higher Voltage of 30 V

Charge systems with higher voltages than V_{Smax} can be realized with the additional expander circuitry, as shown in figure 9. This circuit contains a simple temperature monitoring function. When the temperature level is

reached, the transistor, T_3 , is switched on. If T_3 is switched on and there is current flow into Pin 5, normal charge is terminated.

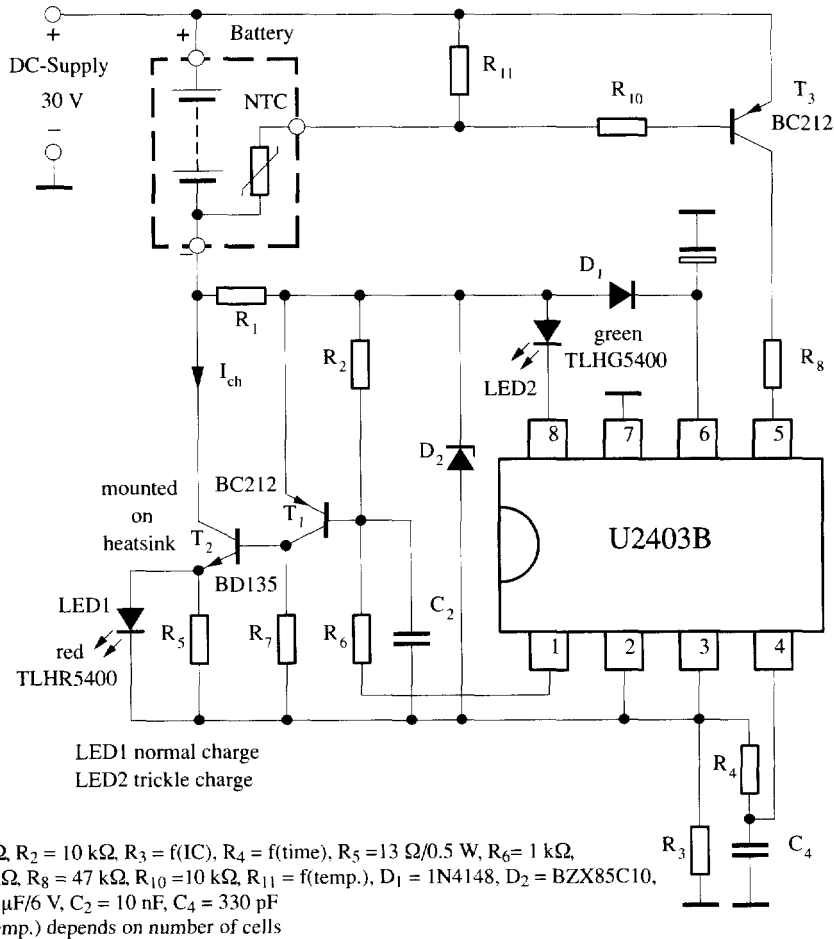

Figure 9. U2403B for higher supply voltage up to 30 V with integrated temperature monitoring

No of Cells	R_{11}
2	13 k Ω
3	8.2 k Ω
4	6.2 k Ω
5	4.7 k Ω

NTC Value	
25°C	6.8 k Ω
40°C	3.9 k Ω
50°C	2.8 k Ω

Package Information

Package DIP8

Dimensions in mm

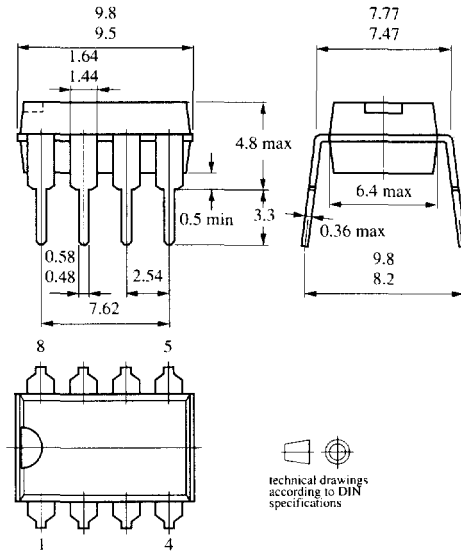

Package SO8

Dimensions in mm

