

OEM Step-Down LED Driver 30 W



DESCRIPTION

The VLLDU-1-30W single channel LED-driver is a convenient and flexible solution for operating high-power LEDs and LED-modules with up to 12 LEDs in series. Due to its compact dimensions it is possible to accommodate several drivers in one application to run also sophisticated LED-modules such as multi array or multi color modules with a constant current per LED string independent from forward voltage variations. The output current can be adjusted by applying an external control signal, either a DC voltage or a PWM signal, to the "PWM" pin.

PRODUCT GROUP

Product group: LED
 Package: PCB, 5 pins
 Product series: LED drivers

FEATURES

- Single channel LED driver
- Suitable to drive up to 12 InGaN LEDs in series
- Input voltage: 6 V to 48 V
- Output current: typ. 350 mA and 670 mA selectable via jumper (other output currents customized), 670 mA predefined
- Typ. 2 % output current accuracy
- Dimmable via PWM or DC voltage
- Inherent open-circuit LED protection
- Dimensions in mm (l x w x h): 35 x 14 x 6
- PCB material: FR4 with white top-coat lacquer
- Typ. 91 % efficiency (LED string with 6 LEDs at 670 mA)

APPLICATIONS

High power LED lighting such as:

- General lighting
- Street lighting
- Architectural lighting
- Illuminated signs
- Refrigerator lights
- Emergency lighting

PARTS TABLE

PART	TYP. INPUT VOLTAGE (V)	NUMBER OF LED STRINGS (MAX.)	NUMBER OF LEDs PER STRING (MAX.)	MAX. OUTPUT POWER (W)	SUPPORTS DIMMING	DRIVER FOR LED MODULES
VLLDU-1-30W	6 to 48	1	12	30	Yes	VLSL. and VLPC. series

ABSOLUTE MAXIMUM RATINGS ($T_{amb} = 25\text{ }^{\circ}\text{C}$, unless otherwise specified)

VLLDU-1-30W

PARAMETER	TEST CONDITION	SYMBOL	VALUE	UNIT
Output Power	For standard configuration: $I_{OUT} = 670\text{ mA}$	$P_{OUT\ max.}$	30	W
Input Voltage		V_{IN}	48	V
Operating temperature range	Measuring point = package converter I_C	T_{amb}	- 40 to + 100	$^{\circ}\text{C}$
Storage temperature range		T_{stg}	- 50 to + 125	$^{\circ}\text{C}$
Relative humidity	Not condensing	RH	5 to 80	%

ELECTRICAL SPECIFICATIONS ($T_{amb} = 25\text{ }^{\circ}\text{C}$, unless otherwise specified)						
VLLDU-1-30W						
PARAMETER	CONDITIONS	SYMBOL	MIN.	TYP.	MAX.	UNIT
Input voltage		V_{IN}	6	-	48	V
Recommended difference of V_{IN} to V_{LED} ⁽¹⁾		V_{IN} to V_{LED}	3	-	5	V
Output current 1	Jumper 1	I_{OUT1}	-	350	-	mA
Output current 2	Jumper 1 and 2	I_{OUT2}	-	670	-	mA
Output current accuracy		ΔI_{OUT}	-	2	-	%
PWM Resolution		PWM_{res}	-	-	1000:1	
PWM_IN ⁽²⁾	Off	PWM_{INoff}	-	-	0.1	V
	On	PWM_{INon}	1.25	-	48	V
	Switch on time	t_{on}	130	-	-	ns
	Switch off time	t_{off}	70	-	-	ns
	Analog input	$PWM_{INanalog}$	0.3	-	-	V
Typical internal switching frequency	PWM	f_{int}	100	-	500	kHz
Efficiency	LED string with 6 LEDs at 20 V and 670 mA	η_{el}	-	91	-	%

Notes

- ⁽¹⁾ If the voltage difference is higher than 5 V between driver input voltage and LED string voltage, the module should be cooled. It is not allowed to rise up the converter IC above maximum allowed temperature.
- ⁽²⁾ No connection is not allowed.

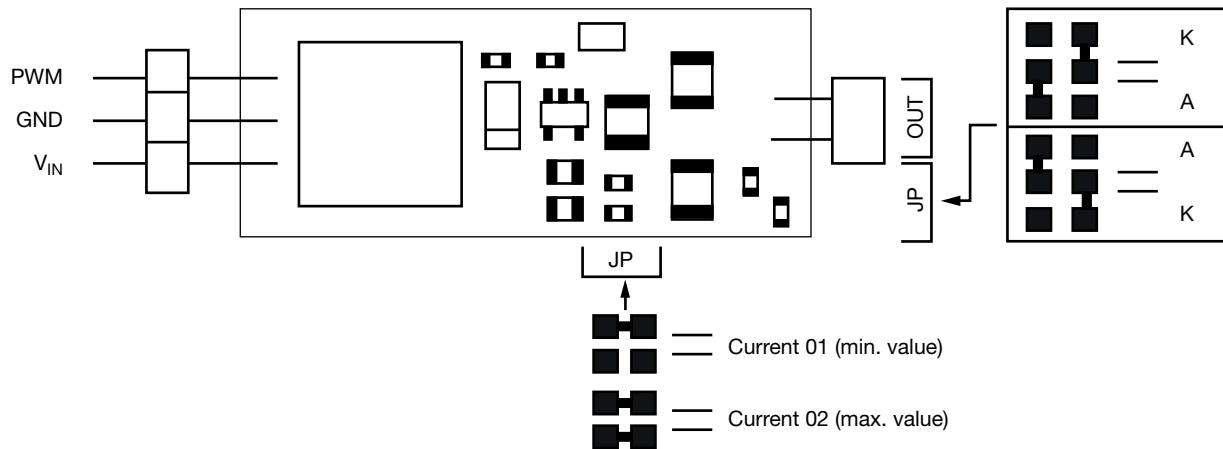
TERMINAL PLAN

Connections

PWM = control input

GND = external ground

V_{IN} = input voltage

LED_OUT = LED output (selectable direction)



ADJUSTMENT CONTROL VIA DC VOLTAGE

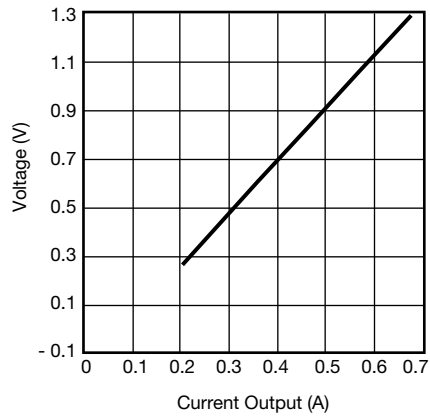

LED CONFIGURATION AND PROTECTION

- Max. number of LEDs: 12 LED (typ. 3.5 V forward voltage at 48 V V_{IN})
- Inherent open-circuit LED protection

OPTIONAL CONFIGURATION (1)

- Max. 48 W output efficiency
- 1 A output current

Note

(1) Only with cooling of step-down I_C , max. allowed temperature on I_C housing 100 °C



Disclaimer

ALL PRODUCT, PRODUCT SPECIFICATIONS AND DATA ARE SUBJECT TO CHANGE WITHOUT NOTICE TO IMPROVE RELIABILITY, FUNCTION OR DESIGN OR OTHERWISE.

Vishay Intertechnology, Inc., its affiliates, agents, and employees, and all persons acting on its or their behalf (collectively, "Vishay"), disclaim any and all liability for any errors, inaccuracies or incompleteness contained in any datasheet or in any other disclosure relating to any product.

Vishay makes no warranty, representation or guarantee regarding the suitability of the products for any particular purpose or the continuing production of any product. To the maximum extent permitted by applicable law, Vishay disclaims (i) any and all liability arising out of the application or use of any product, (ii) any and all liability, including without limitation special, consequential or incidental damages, and (iii) any and all implied warranties, including warranties of fitness for particular purpose, non-infringement and merchantability.

Statements regarding the suitability of products for certain types of applications are based on Vishay's knowledge of typical requirements that are often placed on Vishay products in generic applications. Such statements are not binding statements about the suitability of products for a particular application. It is the customer's responsibility to validate that a particular product with the properties described in the product specification is suitable for use in a particular application. Parameters provided in datasheets and/or specifications may vary in different applications and performance may vary over time. All operating parameters, including typical parameters, must be validated for each customer application by the customer's technical experts. Product specifications do not expand or otherwise modify Vishay's terms and conditions of purchase, including but not limited to the warranty expressed therein.

Except as expressly indicated in writing, Vishay products are not designed for use in medical, life-saving, or life-sustaining applications or for any other application in which the failure of the Vishay product could result in personal injury or death. Customers using or selling Vishay products not expressly indicated for use in such applications do so at their own risk. Please contact authorized Vishay personnel to obtain written terms and conditions regarding products designed for such applications.

No license, express or implied, by estoppel or otherwise, to any intellectual property rights is granted by this document or by any conduct of Vishay. Product names and markings noted herein may be trademarks of their respective owners.

Material Category Policy

Vishay Intertechnology, Inc. hereby certifies that all its products that are identified as RoHS-Compliant fulfill the definitions and restrictions defined under Directive 2011/65/EU of The European Parliament and of the Council of June 8, 2011 on the restriction of the use of certain hazardous substances in electrical and electronic equipment (EEE) - recast, unless otherwise specified as non-compliant.

Please note that some Vishay documentation may still make reference to RoHS Directive 2002/95/EC. We confirm that all the products identified as being compliant to Directive 2002/95/EC conform to Directive 2011/65/EU.

Vishay Intertechnology, Inc. hereby certifies that all its products that are identified as Halogen-Free follow Halogen-Free requirements as per JEDEC JS709A standards. Please note that some Vishay documentation may still make reference to the IEC 61249-2-21 definition. We confirm that all the products identified as being compliant to IEC 61249-2-21 conform to JEDEC JS709A standards.