

FM-Demodulator for SAT TV with Switchable Input

TDA 6142-5X

Preliminary Data

Bipolar IC

Features

- High input sensitivity results in excellent carrier/noise behaviour
- Reduced noise bandwidth for the prescaler with 480-MHz LC circuit
- Limitation of the prescaler's internal bandwidth to 960 MHz
- Due to the LC circuit improvement stability against oscillations
- Interferences reduced by damping higher frequencies with LC circuit
- Switch for double SAW filter input integrated.



P-DSO-20-1

Type	Ordering Code	Package
TDA 6142-5X	Q67000-A5173	P-DSO-20-1 (SMD)

Amplifier and IF demodulator for satellite applications, consisting of: four-stage limiter amplifier with selection circuit and input selector for two IF-inputs, each with a base stage; divider by 4; video amplifier; AGC regulator; AFC-output with adjustable steepness; polarity reversal of the video signal.

Application

Used in indoor units.

Pin Configuration
(top view)

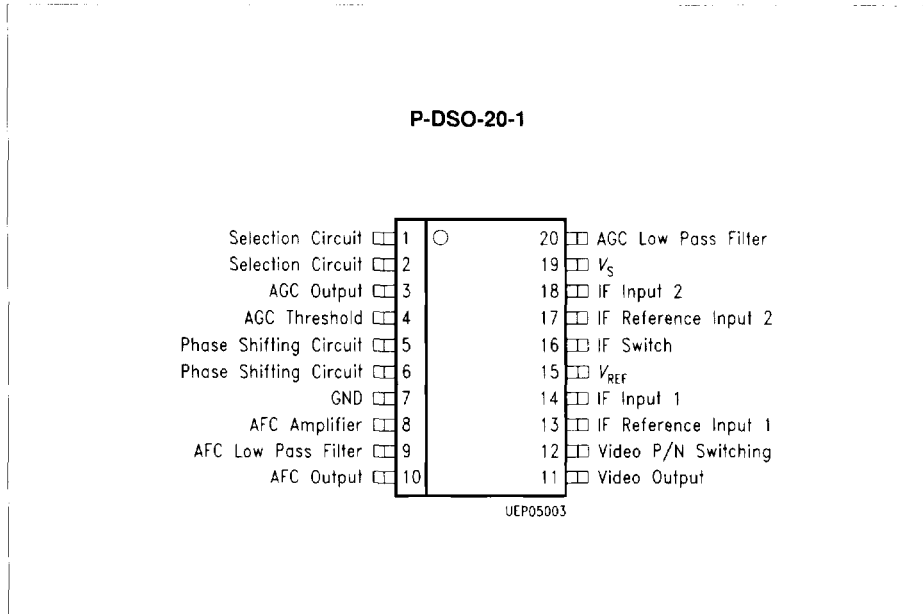

Pin Definitions and Functions

Pin No.	Function
1	Connection for parallel resonance circuit
2	Connection for parallel resonance circuit
3	AGC-control voltage output
4	AGC-threshold adjust
5	Demodulator tank circuit
6	Demodulator tank circuit
7	Ground
8	AFC-preamplifier output
9	AFC-low pass filter and feedback point for AFC-sensitivity setting
10	AFC-output to A/D-converter and AFC-low pass filter
11	Video output
12	Video polarity switch input, positive/negative modulation
13	IF-reference input 1
14	IF-input 1, e.g. $\Delta f = 27$ MHz
15	Reference voltage output
16	IF-input select for IF-input 1 or 2
17	IF-reference input 2
18	IF-input 2, e.g. $\Delta f = 18$ MHz
19	Supply voltage 5 V
20	AGC-low pass filter

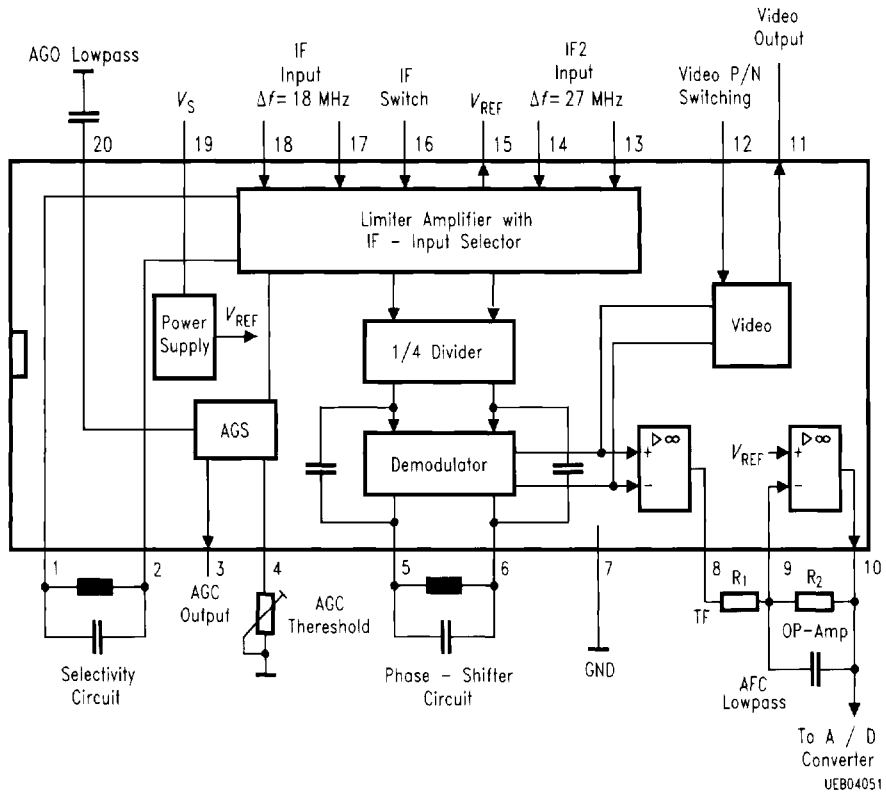

Block Diagram

Circuit Description

The FM modulated satellite IF signal is fed to both low-ohm symmetrical inputs of the limiting amplifier via a SAW filter with two symmetrical outputs and different bandwidths. With an external DC voltage at pin 16 of the IF input selector, an IF-input-signal can be switched through the IF-input 1 or IF-input 2. By high frequency blocking of the limiting amplifier's symmetrical inputs, asymmetrical operation is also possible, but with increased noise. An external selection circuit in the penultimate amplifier stage produces good selectivity of the limiting amplifier and thus provides a better suppression of harmonics.

The output signal of the amplifier is fed to a divider, which splits the frequency into four. The signal is then led to a quadrature demodulator, once directly, and once with phase shift produced by an external phase-shifting circuit.

The demodulated video signal is amplified and is available at the video output. The polarity of this signal can be inverted by a DC voltage applied from outside to the polarity reversal input.

The demodulated video signal is likewise used for AFC regulation. It is fed via a preamplifier to an inverting OP amplifier at which an internal reference voltage is present. Any frequency offset appears as a varying DC voltage, which can in turn be led to an external A/D converter. The AFC S-curve and the amplification of the OPs can be adjusted via an external resistor.

The information for the field strength of the FM modulated satellite IF signal is present as DC voltage at both the AGC output and the AGC low pass filter. A pot can be used to change the AGC threshold. The IF stage of the satellite tuner, or a prestage, can be regulated via the AGC output by amplification.

Absolute Maximum Ratings

$T_A = 0$ to 70 °C

Parameter	Symbol	Limit Values		Unit	Test Condition
		min.	max.		
Supply voltage	V_S	0	6	V	
Selectivity circuit	$V_{1,2}$	0	6	V	
AGC-control voltage output	V_3	1	13	V	Open collector
AGC-threshold input	V_4	0.3	2	V	
Demodulator LC-circuit input	$V_{5,6}$	- 0.3	3	V	
AFC-amplifier	V_8	0	6	V	
AFC-low pass filter	V_9	0	5	V	
AFC-output	V_{10}	0	5	V	
Video output	V_{11}	1	5	V	
Video P/N-switching	V_{12}	- 0.3	6	V	
IF-inputs	$V_{13, 14, 17, 18}$	0.3	3	V	
Reference voltage	V_{15}	0.3	5	V	
IF-input selector	V_{16}	0.3	5	V	
AGC-low pass filter	V_{20}	- 0.3	5	V	
Junction temperature	T_J		150	°C	
Storage temperature	T_{stg}	- 40	125	°C	
Thermal resistance	$R_{th SA}$		125	K/W	

Operating Range

Supply voltage	V_S	4.5	5.5	V
Input frequency range	f_{i5}	360	560	MHz
Ambient temperature during operation	T_A	0	70	°C

Characteristics

$T_A = 25\text{ }^\circ\text{C}$; $V_S = 5\text{ V} \pm 10\%$ (test circuit 1)

Parameter	Symbol	Limit Values			Unit	Test Condition
		min.	typ.	max.		
Power consumption	I_S	30	40	50	mA	

Input Sensitivity

IF-input	a_{IFin}	-65		3	dBm	$f_{13, 14 \text{ \& 17, 18}} = 480\text{ MHz}$
----------	------------	-----	--	---	-----	---

IF-Input Switching

IF-input 1	V_{16}	3.2		5	V	
IF-input 2	V_{16}	0		2.8	V	

Video Output

Video voltage ($\Delta f = 13.5\text{ MHz}$)	V_{11}	400		600	mV	
Distortion factor	THD			< 1	%	
Signal/noise ratio	S/N			70	dB	

Video P/N-Switching

Positive polarity Input current	V_{12} I_{12H}	3.5		5 50	V μA	
Negative polarity Input current	V_{12} I_{12L}	0		1 -50	V μA	

AGC-Current

$a_{IFin} = -28\text{ dBm}$	I_3			10	μA	$V_3 = 8\text{ V}$; Resistor at Pin 4 = $4.7\text{ k}\Omega$
$a_{IFin} = -18\text{ dBm}$	I_3			500	μA	

AFC-Voltage (Open-collector current limited)

$f_{IFin} = 480\text{ MHz}$	V_{10}			2.4	V	$R_2/R_1 = 7$
$f_{IFin} = 440\text{ MHz}$	V_{10}			V_S	V	$R_2/R_1 = 7$
$f_{IFin} = 520\text{ MHz}$	V_{10}			-0.9 V	V	$R_2/R_1 = 7$
				0.05	V	

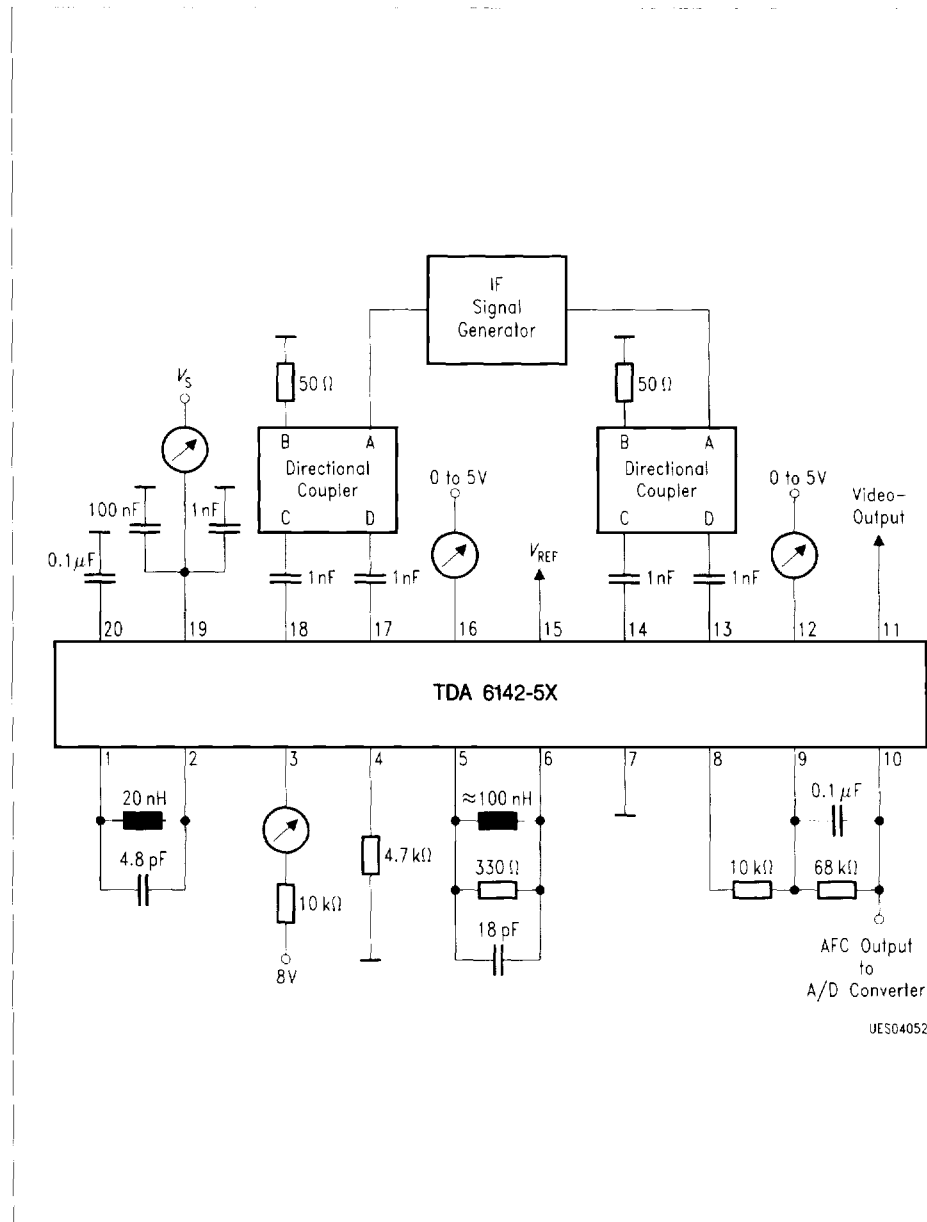

Test Circuit 1

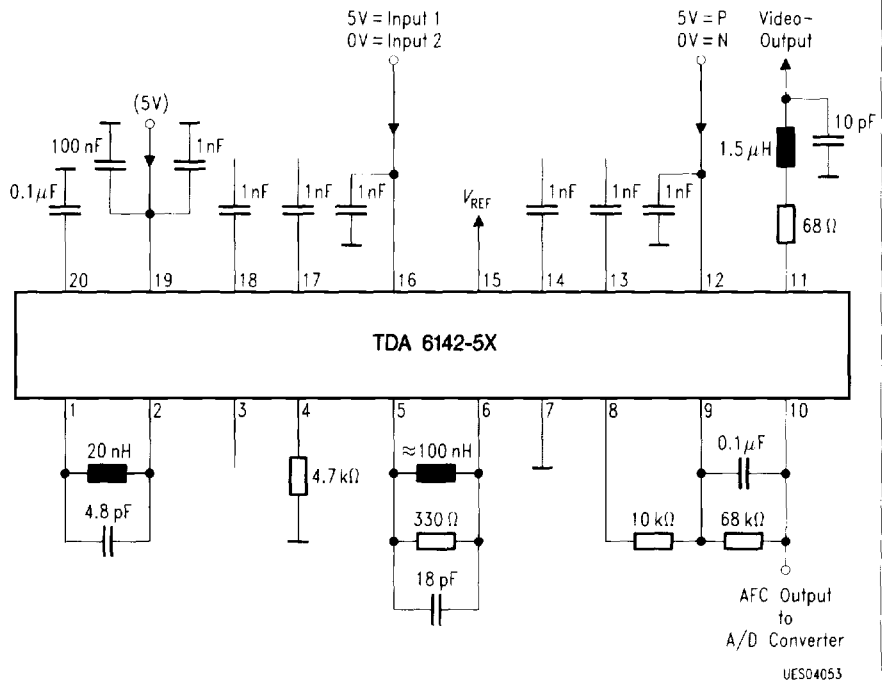

Application Circuit

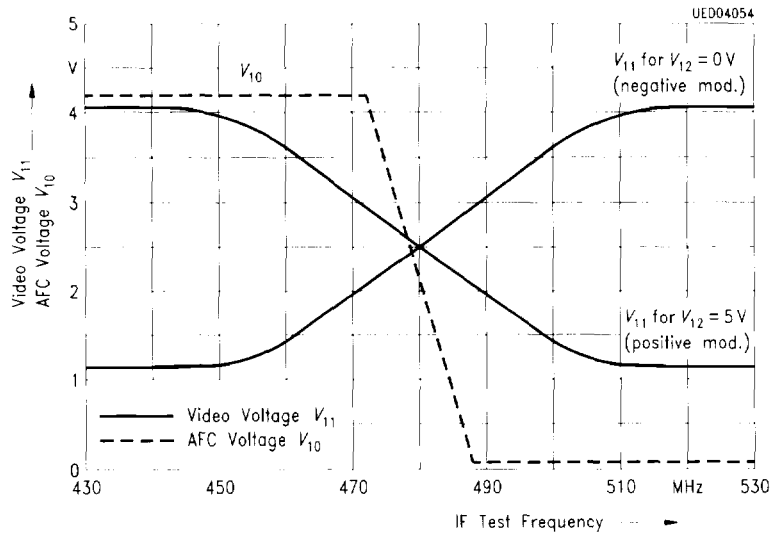

Diagram 1

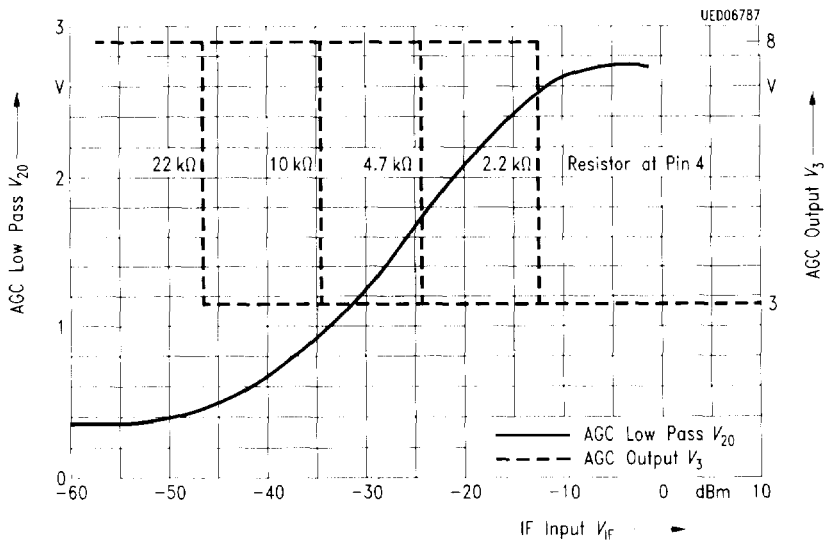

Diagram 2