

**ARM<sup>®</sup> Cortex<sup>®</sup>-M**

**32-bit Microcontroller Table of Contents**

1.	GENERAL DESCRIPTION.....	2
2.	FEATURES .....	3
3.	FAMILY OVERVIEW .....	5
4.	PIN DESCRIPTION.....	7
5.	ITEM VS PIN TABLE.....	8
6.	BLOCK DIAGRAM .....	9
7.	ELECTRICAL CHARACTERISTICS .....	10
	7.1 Absolute Maximum Ratings.....	10
	7.2 D.C. Characteristics .....	10
	7.3 A.C. Characteristics .....	11
8.	TYPICAL APPLICATION CIRCUITS.....	12
9.	REVISION HISTORY .....	14

**1. GENERAL DESCRIPTION**

The N567Hxxx is a powerful microcontroller (uC) dedicated to speech and melody synthesis applications. With the help of the embedded 8-bit microprocessor & dedicated H/W, the N567Hxxx can synthesize 8-channel speech+melody simultaneously.

The two channels of synthesized speech can be in different kinds of format, for example ADPCM and MDPCM. The N567Hxxx can provide 8-channel high-quality wavetable melody, which can emulate the characteristics of musical instruments, such as piano and violin. More colorful melody effects are implemented in N567Hxxx series, such as modulation, vibrato, and pitch-bending etc. The output of speech/melody channels are mixed together through the on-chip digital mixer to produce colorful effects. With these hardware resources, the N567Hxxx is very suitable for high-quality and sophisticated scenario applications.

The N567Hxxx provides at most 32 I/O pins, 384 bytes RAM , IR carrier, Serial Interface Management (SIM), and more sophisticated applications, such as interactive toys, cartridge toys and final count down function. 3-pair LED output pins with 64-level control means that numerous combination of RGB colors may result in a versatility of colorful effects. In addition, N567Hxxx also provides PWM mode audio output to save power during playback and Watch Dog Timer to prevent latch-up situation occurring.

The N567Hxxx family contains several items with different playback duration as shown below: (@4-bit NM4 algorithm, 6 KHz sampling rate)

<b>Item</b>	<b>N567H030</b>	<b>N567H041</b>	<b>N567H080</b>	<b>N567H120</b>	<b>N567H160</b>	<b>N567H200</b>
*Duration	34 sec.	44 sec.	84 sec.	124 sec.	158 sec.	192 sec.
<b>Item</b>	<b>N567H240</b>	<b>N567H280</b>	<b>N567H330</b>	<b>**N567H121</b>	<b>**N567H161</b>	<b>**N567H201</b>
*Duration	233 sec.	272 sec.	311 sec.	124 sec.	158 sec.	192 sec.

**Note:** \*: The duration time is based on 4-bit NM4 at 6 KHz sampling rate. The firmware library and timber library have been excluded from user's ROM space for the duration estimation.

**Note:** \*\*: N567H121/161/201 are modified from N567H120/160/200 respectively to consist with OTP's pad sequence.

## 2. FEATURES

- Wide range of operating voltage:
  - 8 MHz @ 3.0 volt ~ 5.5 volt
  - 6 MHz @ 2.4 volt ~ 5.5 volt
- Oscillator
  - Trim function -Build in Rosc and system clock setting: 4MHz, 6MHz or 8MHz by Mask Option
  - X'tal oscillator –Only in N567H240/280/330/041/030 by Mask Option
    - ◆ Add external Crystal 8MHz~16MHz for system clock 4M~8MHz
- Power management:
  - 4 ~ 8 MHz system clocks, with Ring type or crystal type.
  - Stop mode for stopping all IC operations
    - ◆ Status changes of the IP0 and BP0~BP2 pins can wake up the chip
- Provides up to 8 inputs and 24 I/O pins
  - N567H030~201: 24I/O
  - N567H240~330: 8I + 24I/O
- Audio output : 1 speaker outputs, mono effect available
  - DAC : maximum output is 3mA/5mA , (10+3)-bit without Noise Shaping to drive speaker output.
  - PWM: direct drive 12 bit with Noise Shaping to save power consumption.
- F/W speech synthesis:
  - Multiple format parser that supports
    - ◆ New 4-bit MDPCM(NM4), 5-bit MDPCM(MDM), 4-bit MDPCM(MD4), 4-bit ADPCM(APM), 8-bit Log PCM(LP8) algorithm can be used
    - ◆ Pitch shippable ADPCM for voice changer application
  - Dual-sample rate voice synthesis
- F/W Melody synthesis:
  - 6 melody channels that can emulate characteristics of musical instruments
  - Multi-MIDI files simultaneous
  - Multi-MIDI channels dynamic control
  - More MIDI events are supported for colorful melody playback, such as modulation wheel, pitch-bending, pedal, pitch-shift, and vibrato...etc.
- Speech and melody can be playing at the same time
  - 2 channels speech + 6 channels wavetable melody
  - 1 channel speech + 7 channels wavetable melody
  - 8 channels wavetable melody
- Built-in IR carrier generation circuit for simplifying firmware IR application
- Built-in TimerG1 for general purpose applications
- Harmonized synchronization among MIDI, Speech, LED, and Motor
- Build-in 3-pair LED outputs with 64-level control of brightness in N567H240~330
  - BP00/02/04 are defined as 3 H/W PWM I/O pins. They can be paired with BP01/03/05 respectively by same (or opposite) phase of output waveform

- Built-in Watch-Dog Timer (WDT) and Low Voltage Reset (LVR) by mask option
- Provide Serial Interface Management (SIM) to access the external memory in N567H030~080 and N567H240~330
  - W55F, W551C
  - SPI flash/ROM
- Support **PowerScript™** for developing codes in easy way
- Full-fledged development system
  - Source-level ICE debugger (Assembly & **PowerScript™** format)
  - **Ultra I/O™** tool for event synchronization mechanism
  - ICE system with USB port
  - User-friendly GUI environment
- Available package form:
  - COB is essential

### 3. FAMILY OVERVIEW

The characteristics of N567Hxxx series are depicted in Table 1.

Part Number	N567H030	N567H041	N567H080	N567H120, /N567H121	N567H160 /N567H161
ROM (Byte)	126K	158K	286K	416K	528K
RAM (Byte)	384	384	384	384	384
Duration <sup>1</sup>	34 sec	44 sec	84 sec	124 sec	158 sec
System Clock	TRIM/X'tal	TRIM/X'tal	TRIM	TRIM	TRIM
In : Bid <sup>2</sup>	0 : 24	0 : 24	0 : 24	0 : 24	0 : 24
Audio Output	DAC PWM	DAC PWM	DAC PWM	DAC PWM	DAC PWM
Speaker	1	1	1	1	1
Mixer Input	8	8	8	8	8
Synthesis Algorithm	MDPCM ADPCM PCM	MDPCM ADPCM PCM	MDPCM ADPCM PCM	MDPCM ADPCM PCM	MDPCM ADPCM PCM
IR-Carrier (Tx)	✓	✓	✓	✓	✓
64-Level Output	X	X	X	X	X
Watch Dog Timer (WDT)	✓	✓	✓	✓	✓
Low Voltage Reset (LVR)	✓	✓	✓	✓	✓
SIM for SPI Flash Interface	✓	✓	✓	X	X
Stop mode	✓	✓	✓	✓	✓
PowerScript	✓	✓	✓	✓	✓

<sup>1</sup> The F/W library & program code are excluded from the ROM space for the duration estimate, which is based on 6-KHz sample rate & 4-bit NM4 algorithm.

<sup>2</sup> "In" is the number of input pins; "Bid" is the number of Bi-directional pins.

Part Number	N567H200 /N567H201	N567H240	N567H280	N567H330
ROM (Byte)	638K	768K	896K	1022K
RAM (Byte)	384	384	384	384
Duration	192 sec	233 sec	272 sec	311 sec
System Clock	TRIM	TRIM/X'tal	TRIM/X'tal	TRIM/X'tal
In : Bid	0 :24	8 : 24	8 : 24	8 : 24
Audio Output	DAC PWM	DAC PWM	DAC PWM	DAC PWM
Speaker	1	1	1	1
Mixer Input	8	8	8	8
Synthesis Algorithm	MDPCM ADPCM PCM	MDPCM ADPCM PCM	MDPCM ADPCM PCM	MDPCM ADPCM PCM
IR-Carrier (Tx)	✓	✓	✓	✓
64-Level Output	X	*3-Pair	*3-Pair	*3-Pair
Watch Dog Timer (WDT)	✓	✓	✓	✓
Low Voltage Reset (LVR)	✓	✓	✓	✓
SIM for W55F/W551C	X	✓	✓	✓
SIM for SPI Flash Interface	X	✓	✓	✓
Stop mode	✓	✓	✓	✓
PowerScript	✓	✓	✓	✓

Note \*:BP00/02/04 are defined as 3 H/W PWM I/O pins. They can be paired with BP01/03/05 respectively by same (or opposite) phase of output waveform

Table 1: N567Hxxx family selection guide

4. PIN DESCRIPTION

PIN NAME	I/O	FUNCTION
/RESET	In	IC reset input with an internal pull-up resistor, low active.
OSCIN	I	Main-clock oscillation input for X'tal mode. Build-in ROSC by mask option.
OSCOU	O	Main-clock oscillation output for X'tal.
IP00~IP07	In	General input port with pull-high selection. Each input pin can be programmed to generate interrupt request and used to release IC from STOP mode. It is provided in N567H240~330 only.
BP00~BP07	I/O	General input/output pins. When used as output pin, it can be open-drain or CMOS type and it can sink 25mA for high-current applications. When used as input pin, there may have a pull-high option and generate interrupt request to release IC from STOP mode. When BP07 is used as output pin, it can be the IR transmission carrier for IR applications. Only for N567H240/280/330. BP00/02/04 can be set as 3-pin H/W PWM output with 64-level resolution. They can be paired with BP01/03/05 (also H/W PWM output) respectively with same or opposite phase of output waveform.
BP10~BP17	I/O	General input/output pins. When used as output pin, it can be open-drain or CMOS type. When used as input pin, there may have a pull-high option and generate interrupt request to release IC from STOP mode. When serial interface management (SIM) is enabled, and set memory type as W55F/W551C, BP10~12 are used to be an interface with the external memory, W55Fxx or W551Cxxx. If set memory to SPI flash, BP10~13 are used to be an interface.
BP20~BP27	I/O	General input/output pins. When used as output pin, it can be open-drain or CMOS type. When used as input pin, there may have a pull-high option and generate interrupt request to release IC from STOP mode.
PWM+/DAC	O	PWM driver positive output or Current type DAC output
PWM-	O	PWM driver negative output
VDD	Power	Positive power supply for uP and peripherals.
VSS	Power	Negative power supply for uP and peripherals.
VDD_SPK	Power	Positive power supply for speaker driver.
VSS_SPK	Power	Negative power supply for speaker driver.
VDD_SIM	Power	Positive power supply for serial interface Management (SIM) BP10~13 Only providing in N567H240~N567H330. For non-SIM application, it should be connect to VDD to keep normal standby current.
VDD_OSC	Power	Positive power supply for oscillator. Only providing in N567H240~N567H330. It must be connected to VDD.
VSS_OSC	Power	Negative power supply for oscillator. Only providing in N567H240~N567H330. This pad must be connected to VSS.

5. ITEM VS PIN TABLE

PIN name	H030/041	H080	H120/160/200 H121/161/201	H240/280/330	Comment
BP00~07	V	V	V	V	
BP10~17	V	V	V	V	
BP20~27	V	V	V	V	
IP00~07	-	-	-	V	
/RESET	V	V	V	V	
PWM+/DAC	V	V	V	V	
PWM-	V	V	V	V	
OSCIN	V	V	V	V	
OSCOUT	V	-	-	V	Crystal mode
VDD	V	V	V	V	
VSS	V	V	V	V	
VDD_SPK	V	V	V	V	Support speaker power
VSS_SPK	V	V	V	V	
VDD_SIM	-	-	-	V	Support BP10~13 SIM interface power
VDD_OSC	-	-	-	V	Support OSCIN/OUT power
VSS_OSC	-	-	-	V	

6. BLOCK DIAGRAM

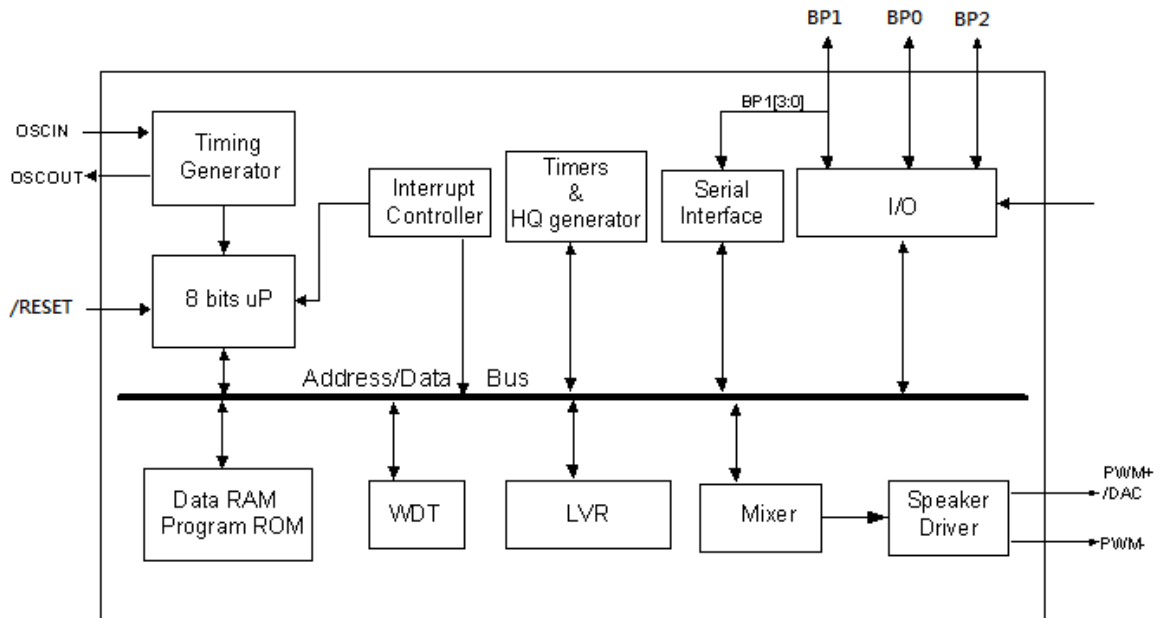

## 7. ELECTRICAL CHARACTERISTICS

### 7.1 Absolute Maximum Ratings

PARAMETER	RATING	UNIT
Supply Voltage to Ground Potential	-0.3 to +7.0	V
D.C. Voltage on Any Pin to Ground Potential	-0.3 to $V_{DD} + 0.3$	V
Operating Temperature	0 to +70	°C
Storage Temperature	-55 to +150	°C

**Note:** Exposure to conditions beyond those listed under Absolute Maximum Ratings may adversely affect the life and reliability of the device.

### 7.2 D.C. Characteristics

( $V_{DD} - V_{SS} = 4.5\text{ V}$ ,  $F_M = 8\text{ MHz}$ ,  $T_a = 25^\circ\text{C}$ , No Load unless otherwise specified)

PARAMETER	SYM.	TEST CONDITIONS	SPEC.			UNIT
			Min.	Typ.	Max.	
Operating Voltage	$V_{DD}$	$F_{SYS} = 6\text{ MHz}$	2.4	-	5.5	V
		$F_{SYS} = 8\text{ MHz}$	3.0	-	5.5	V
Operating Current	$I_{OP}$	$F_{SYS} = 8\text{ MHz}$ , normal operation	-	8	12	mA
Standby Current	$I_{SB}$	STOP mode	-	1	2	$\mu\text{A}$
Input Low Voltage	$V_{IL}$	All input pins	$V_{SS}$	-	$0.3 V_{DD}$	V
Input High Voltage	$V_{IH}$	All input pins	$0.7 V_{DD}$	-	$V_{DD}$	V
Input Current I/O pins	$I_{IN1}$	$V_{IN} = 0\text{V}$ , pulled-high resistor = 500k ohm	-5	-9	-14	$\mu\text{A}$
Input Current I/O pins	$I_{IN2}$	$V_{IN} = 0\text{V}$ , pulled-high resistor = 150k ohm	-15	-30	-45	$\mu\text{A}$
Output Current (BP0)	$I_{OL}$	$V_{DD} = 3\text{V}$ , $V_{OUT} = 0.4\text{V}$	8	12	-	mA
	$I_{OH}$	$V_{DD} = 3\text{V}$ , $V_{OUT} = 2.6\text{V}$	-4	-8	-	mA
	$I_{OL}$	$V_{DD} = 4.5\text{V}$ , $V_{OUT} = 1.0\text{V}$	-	35	-	mA
	$I_{OH}$	$V_{DD} = 4.5\text{V}$ , $V_{OUT} = 3.5\text{V}$	-	-20	-	mA
Output Current (BP1, BP2)	$I_{OL}$	$V_{DD} = 3\text{V}$ , $V_{OUT} = 0.4\text{V}$	4	6	-	mA
	$I_{OH}$	$V_{DD} = 3\text{V}$ , $V_{OUT} = 2.6\text{V}$	-4	-8	-	mA
	$I_{OL}$	$V_{DD} = 4.5\text{V}$ , $V_{OUT} = 1.0\text{V}$	-	15	-	mA
	$I_{OH}$	$V_{DD} = 4.5\text{V}$ , $V_{OUT} = 3.5\text{V}$	-	-20	-	mA
DAC Full Scale Current	$I_{DAC}$	$V_{DD} = 4.5\text{V}$ , $R_L = 100\Omega$	-2.4 -4.0	-3.0 -5.0	-3.6 -6.0	mA
Output Current PWM+ / PWM-	$I_{OL1}$	$R_L = 8\text{ Ohm}$ ,	+200	-	-	mA
	$I_{OH1}$	[PWM+]---[RL]---[PWM-]	-200	-	-	mA

**7.3 A.C. Characteristics**

(V<sub>DD</sub>-V<sub>SS</sub> = 4.5 V, F<sub>M</sub> = 8 MHz, T<sub>a</sub> = 25°C; No Load unless otherwise specified)

PARAMETER	SYM.	TEST CONDITIONS	SPEC.			UNIT
			Min.	Typ.	Max.	
Main-Clock	F <sub>M</sub>	ROSC build-in, @3.0~5.5V	3973	4096	4218	KHz
		ROSC build-in, @3.0~5.5V	5959	6144	6328	
		ROSC build-in, @3.0~5.5V	7946	8192	8437	
Main-Clock	F <sub>M</sub>	ROSC build-in, @2.4~3.6V	3973	4096	4218	KHz
		ROSC build-in, @2.4~3.6V	5959	6144	6328	
Main-Clock Wake-up Stable Time	T <sub>WSM</sub>	2 <sup>16</sup> clock cycle	8		16	mS

8. TYPICAL APPLICATION CIRCUITS

(a) Trim Ring oscillator application

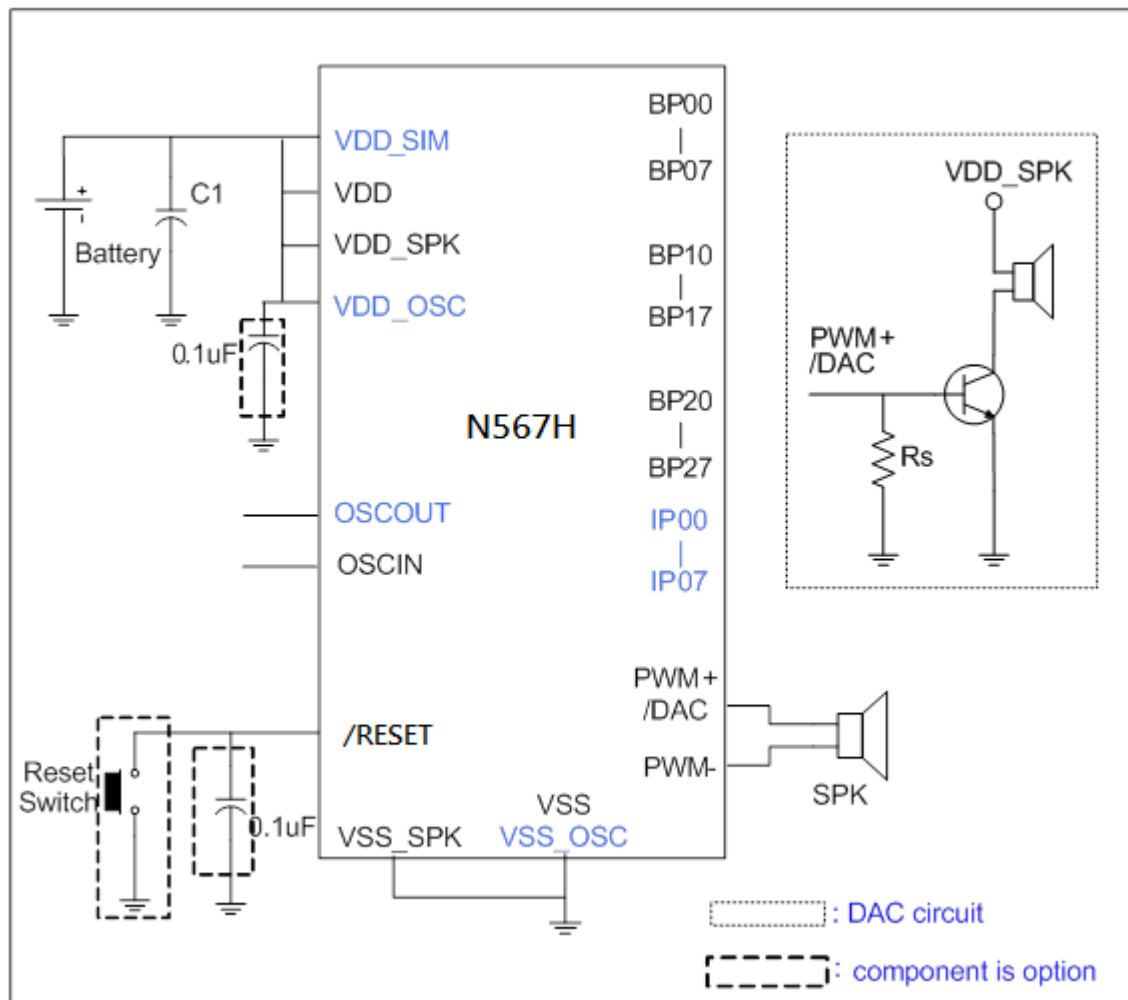

**Notes:**

1. R<sub>osc</sub> is built in N567H chip internally. User needn't connect R<sub>osc</sub> resistor to OSCIN pin.
2. The C1 value is suggested 4.7uF for audio PWM output or 0.1uF for DAC output.
3. The R<sub>s</sub> value is suggested in 270Ω ~ 1KΩ to limit too large DAC output current flowing into transistor.
4. The VDD\_OSC pad must be connected to VDD. To add a 0.1uF capacitor to VSS is optional to improve oscillator stability.
5. The VDD\_SIM pad must be connected to VDD for non-SIM application.
6. The above application circuits are for reference only. No warranty for mass production.

**(b) Crystal application**

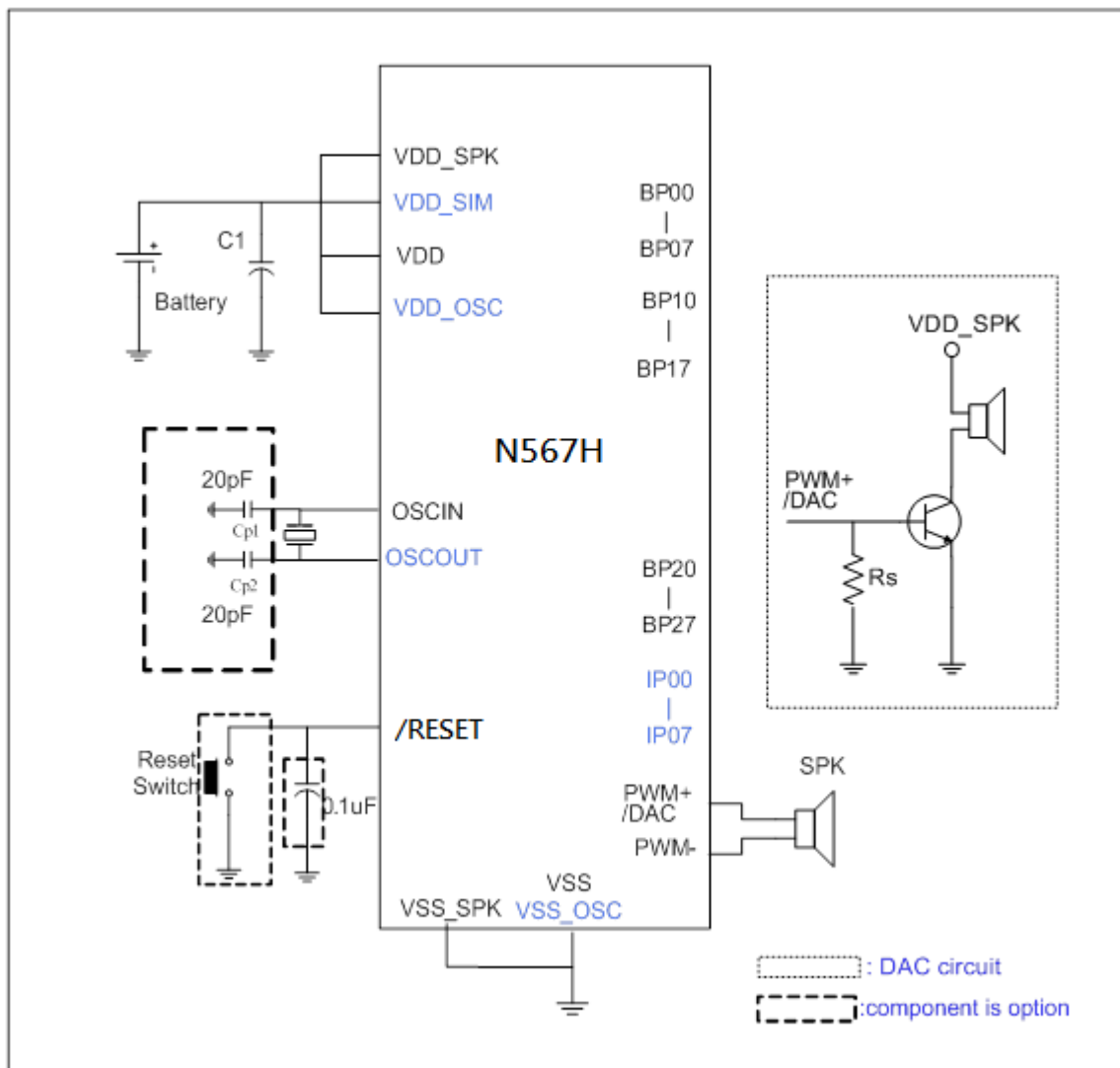

**Notes:**

1. The crystal value must be double of system clock. If System clock is 6MHz, please select 12MHz crystal device. The crystal should be placed close to IC, and the location is as near as possible.
2. The value of Cp1 and Cp2 are depended on PCB layout and crystal type suggested 15~30pF or skip.
3. The C1 value is suggested 4.7uF in audio PWM output and 0.1uF in DAC output.
4. The VDD\_OSC pad must be connected to VDD.
5. The VDD\_SIM pad must be connected to VDD if without SIM application.
6. The above application circuits are for reference only. No warranty for mass production.
7. Other application circuits please refer to Design Guide.

(c) PCB layout guide

1. The IC substrate should be connected to VSS in PCB layout. But VSS\_SPK can't connect with IC substrate directly. Both VSS and VSS\_SPK tie together in battery negative power.
2. Each VDD, VDD\_OSC, VDD\_SIM and VDD\_SPK pad must connect to positive power to support stable voltage for individual function work successfully. (Don't let them floating)

**9. REVISION HISTORY**

VERSION	DATE	REASONS FOR CHANGE	PAGE
A0	June 2009	Preliminary release.	
A1	July 2009	<ul style="list-style-type: none"> <li>➤ SIM is provided in N567H040~080.</li> <li>➤ PWM speaker output is provided in N567H040~080.</li> </ul>	
A2	Aug. 2009	<ul style="list-style-type: none"> <li>➤ Add VDDOSC and VSSOSC in the pin description</li> <li>➤ Remove TEST pad in the pin description</li> <li>➤ Modify N567H240~330 application circuit</li> </ul>	
A3	Aug. 2009	➤ Modify Frequency deviation in 5.3 A.C. Characteristics.	
A4	Sep. 2009	➤ Modify Main Clock and Frequency deviation condition in 5.3 A.C. Characteristics.	
A5	Oct. 2009	➤ Remove LVD function in 2 Features	
A6	Nov. 2009	➤ Revise frequency deviation value of 2.4~3.6V in section 5.3 A.C. Characteristics.	
A7	Feb. 2011	➤ Remove N567H240~330 SPIO function except N567H000 ICE chip	11
		➤ VDD_SPIO/VSS_SPIO and VDD_SIM/VSS_SIM pins must be connect to V <sub>DD</sub> /V <sub>SS</sub> to keep normal standby current.	5
		➤ Update output current for BP1/2 @4.5V/3.0V and update BP0 @4.5V	7
		➤ Update 4.7uF is optional as power stability on DAC application on application circuit	9
A8	Apr. 2011	➤ Update 4.7uF is necessary as power stability on PWM application on application circuit	10
		➤ Add N567Hxx chip family overview	5~6
		➤ Add SIM SPI Flash application circuit for N567H040~080	13
		➤ Update Application Circuit and note description	11~18
		➤ Add power circuit in PCB layout	18
A9	Sep. 2011	➤ N567H240~330 modify VDD_SPI pad to VDD2 which must be connected to VDD.(please refer bonding pad diagram rev. A1)	7
		➤ Modify OSCIN application circuits, for DAC output no connected, PWM output add a 200pF capacitor to VDD to improve voice quality optional.	11~15
		➤ Add new 4-bit MDPCM (NM4) speech synthesis algorithm	3

### Important Notice

Nuvoton Products are neither intended nor warranted for usage in systems or equipment, any malfunction or failure of which may cause loss of human life, bodily injury or severe property damage. Such applications are deemed, "Insecure Usage".

Insecure usage includes, but is not limited to: equipment for surgical implementation, atomic energy control instruments, airplane or spaceship instruments, the control or operation of dynamic, brake or safety systems designed for vehicular use, traffic signal instruments, all types of safety devices, and other applications intended to support or sustain life.

All Insecure Usage shall be made at customer's risk, and in the event that third parties lay claims to Nuvoton as a result of customer's Insecure Usage, customer shall indemnify the damages and liabilities thus incurred by Nuvoton.

---

Please note that all data and specifications are subject to change without notice.  
All the trademarks of products and companies mentioned in this datasheet belong to their respective owners.