

Absolute Maximum Ratings (Ta = 25 °C)			
Symbol	Term	Values	Units
V _{DD15V}	15 V supply voltage (reference for output signals)	18	V
V _{DD5V}	5 V supply voltage (reference for input signals)	6	V
V _{iH}	input signal voltage (HIGH) max.	V _{DD5V} + 0,3	V
V _{iL}	input signal voltage (LOW) min.	GND - 0,3	V
f _{sw}	switching frequency	50	kHz
T _{op} / T _{stg}	operating/storage temp.	-40...+ 85	°C

SEMIDRIVER® IGBT Driver Circuit SKIC 6001

Preliminary Data



Package SOP 28

Electrical Characteristics (Ta = 25 °C) ¹⁾			
Symbol	Term	Values	Units
V _{DD15V}	15 V supply voltage	15 ± 5%	V
V _{DD5V}	5 V supply voltage	5 ± 5%	V
I _{SSV}	supply current (V _{DD5V}); typ ⁴⁾	5-10	mA
I _{S15V}	supply current (V _{DD15V}); typ ⁴⁾	20-30	mA
t _d	propagation time	125	ns
t _{TDSwitch} ^{2) 3)}	dead time interlock; typ.	off, 1, 2, 3, 4	µs
t _{supswitch}	short pulse suppression TOP-BOT depending on input current for input resistor of 4.75kΩ	70	ns
V _{SU}	supply under voltage monitoring using V _{DD15V}	13,0	V
input signal TOP, BOTTOM, SELECT, TDT1, TDT2			
V _{iT+}	input threshold voltage (High)	3,7	V
V _{iT-}	input threshold voltage (Low)	1,5	V
R _{down}	internal pull down resistor (TOP; BOTTOM)	66 ± 2	kΩ
R _{up}	internal pull up resistor (SELECT; TDT1; TDT2)	66 ± 2	kΩ
ERROR Input Signals			
V _{ET+}	input threshold voltage (High)	> 3,7	V
V _{ET-}	input threshold voltage (Low)	< 1,5	V
R _{EU}	internal pull down resistor	22	kΩ
t _{swOSC}	oscillatory frequency DC/DC Converter	500 ³⁾	kHz
t _{Td}	time of interlock of DC/DC Converter	250	ns
Output Signal Error			
I _{outmax}	max. output current at V _{DD5V}	± 5	mA
V _{outmax}	max. output voltage	4,8	V
V _{outmin}	min. output voltage	0,22	V

Features

IGBT-3-phase bridge driver circuit with protection functions

- Interlock of TOP and BOTTOM switches in each halfbridge
- Short pulse suppression
- Supply undervoltage protection
- Generation of the system clock
- Integrated DC/DC-converter driver circuit
- Error monitoring

Typical Applications

- Driving of IGBTs
 - for 3-phase bridge configuration
 - due to isolation (magnetic transformer, optocoupler) can be used for voltages > 1200 V and high power applications

¹⁾ Values for V_{DD15V}; V_{DD5V}; f_{sw}=25kHz

²⁾ input "SELECT" = LOW

= no interlock

³⁾ with f_{sw} = 8 MHz at OSC1, OSC2

⁴⁾ stand by

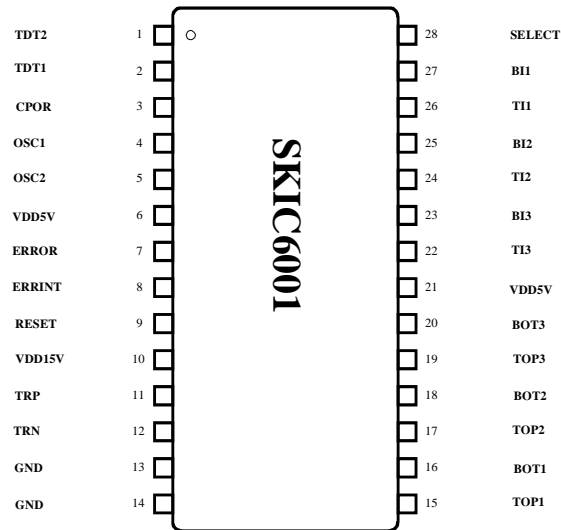

Fig. 1
PIN Array SKIC 6001

Pin-No.	Typ ¹⁾	Name	Description
1	CON	TDT2	determine interlock time for 1, 2, 3 and 4 μ s,
2	CON	TDT1	is only active if interlock mode is chosen with selector
3	CON	CPOR	Power On Reset, connect to 5V or C to GND for delay
4	CON	OSC1	oscillator connection for external 8MHz quartz resonator
5	CON	OSC2	(10M Ω in parallel for stability reasons is recommendable)
6	P	VDD5V	5V power supply
7	OUT	ERROR	output of error memory
8	IN	ERRINT	input of error memory (Active Low)
9	OUT	RESET	RESET signal, "0" : 0V, "1":5V (Active Low)
10	P	VDD15V	15V power supply
11	OUT	TRP	output of driver transistors for DC/DC Converter,
12	OUT	TRN	signal frequency is 500kHz, interlock time is 250ns
13	P	GND	Ground
14	P	GND	
15	OUT	TOP1	driver output for TOP1 "0" : 0V, "1":5V
16	OUT	BOT1	driver output for BOT1 "0" : 0V, "1":5V
17	OUT	TOP2	driver output for TOP2 "0" : 0V, "1":5V
18	OUT	BOT2	driver output for BOT2 "0" : 0V, "1":5V
19	OUT	TOP3	driver output for TOP3 "0" : 0V, "1":5V
20	OUT	BOT3	driver output for BOT3 "0" : 0V, "1":5V
21	P	VDD5V	5V power supply
22	IN	TI3	control input "0" : 0V, "1":5V
23	IN	BI3	control input "0" : 0V, "1":5V
24	IN	TI2	control input "0" : 0V, "1":5V
25	IN	BI2	control input "0" : 0V, "1":5V
26	IN	TI1	control input "0" : 0V, "1":5V
27	IN	BI1	control input "0" : 0V, "1":5V
28	CON	SELECT	interlock optional "0" : 0V, "1":5V

¹⁾ CON...Configuration pin, P...Power Supply, IN...Input, OUT...Output

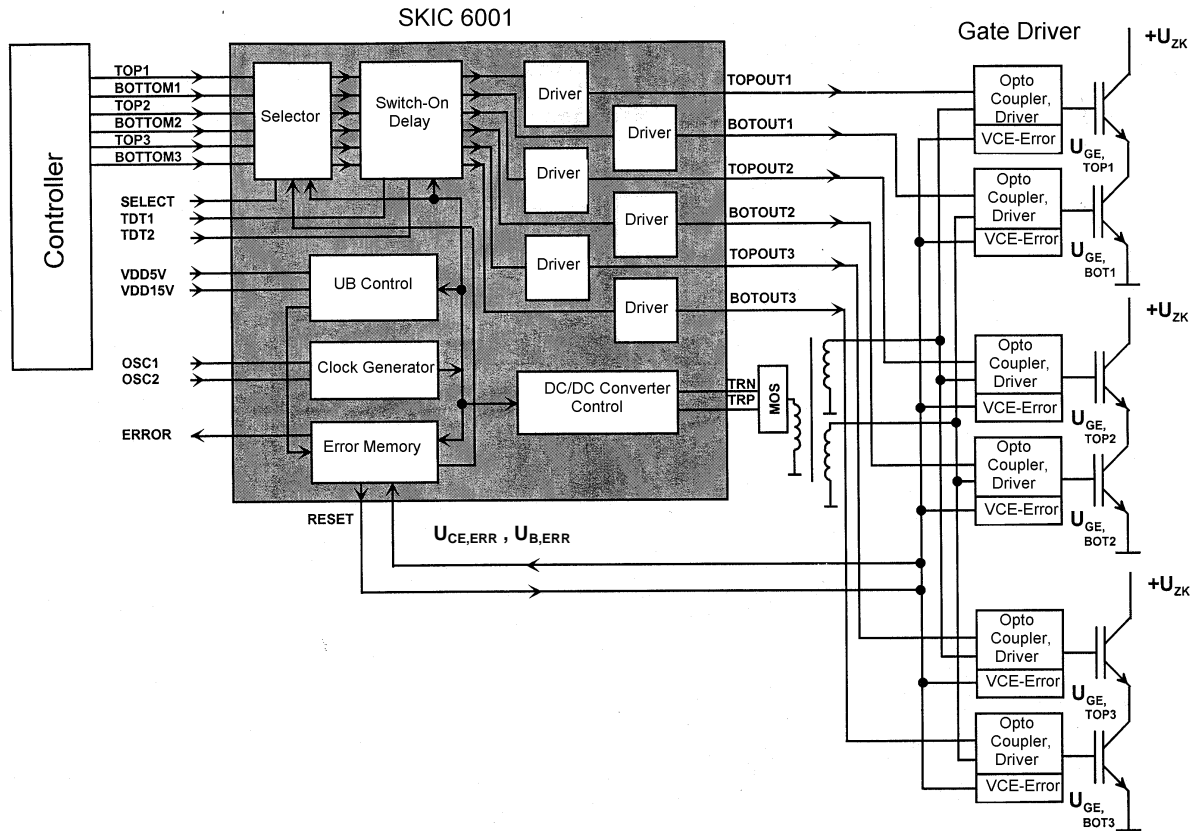

Figure 2: System Configuration of a Propulsion Control with SKIC6001 without Motor

Overview

The integrated intelligent controller circuit (SKIC6001) is presented for the control of IGBTs, especially in a 3-phase bridge, for high power applications and frequencies up to 50kHz. Fig. 2 shows the functional block diagram of the control IC for a propulsion control. It consists of a digital control unit, mostly a microprocessor (μP), the control IC (SKIC 6001), a potential separation (ferrite signal transformer or opto-couplers), the gate driver stages, an IGBT halfbridge and a consumer (as e.g. a motor).

By means of the digital unit a pulse frequency modulation of the IGBT driver signals is possible and, therefore, a power control of the consumer can be realized. The developed control circuit contains the signal processing, power supply, the driving and monitoring functions for IGBTs in a 3-phase bridge application. A power supply of 5V and 15V is necessary. The most important parts, functions and connections are shown in Fig. 2:

- the forward branch with selector, switch on delay, short pulse suppression, driver and signal transformer to the secondary side (high voltage side)
- the backward branch with error detection and processing
- the additional part with clock generator, power supply control and dc/dc converter circuit

The control circuit has several inputs, some of them with a Schmitt-trigger characteristic for increased noise immunity. TOP1..3 and BOTTOM1..3 are the main control inputs. A RESET is generated after all inputs are LOW for $9\mu\text{s}$ (active Low).

With the use of bidirectional opto-couplers the information between primary and secondary side may flow in both directions and high levels of dv/dt and insulation are guaranteed (ferrite signal transformers are also possible).

The high frequency dc/dc converter avoids the requirement of an externally insulated power supply to obtain the necessary voltage and power for the IGBT gates. For this operation the dc/dc converter circuit supplies a 15V signal with a frequency of 500kHz for three halfbridges.

An internal protection function of the SKIC 6001 is the power supply control. The circuit will be blocked, if the 15V-power supply drops under a value of approximately 13,0V. Further error signals as e.g. from the primary side (e.g. for short circuit: V_{CE}) can be fed to the input of ERRINT. All detected error signals are processed in the control IC. The forward driver signal is blocked or the IGBTs are turned off and an error signal appears at the output of the microprocessor. The error storage can be reset by a

SKIC 6001

RESET pulse which is generated, if the inputs (TOP, BOTTOM) are LOW for 9 μ s.

Functional description

Interlock

Fig. 3 demonstrates the right function of the interlock of TOP-and BOTTOM-IGBT.

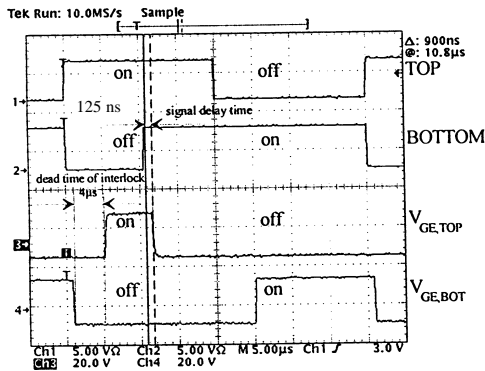

Fig. 3 Interlock function

At first BOTTOM is turned off immediately after the corresponding input signal (at 5 μ s), while TOP is turned on with a delay of about 4 μ s (setting of interlock 4 μ s). After 10 μ s both inputs become „on“. This is not a correct state (both IGBT „on“ means short circuit) and the reason is both outputs are switched off. A switch on of BOTTOM is possible not before TOP is „off“ (at 25 μ s, interlock and delay time about 1 μ s).

Fig. 4 shows the behavior, if the interlock function isn't active (SELECT „low“). Both outputs react immediately to the corresponding input (the difference is the signal delay time of about 125 ns).

The interlock time may be chosen by connecting pin TDT1 and TDT2 to GND (0) or 5V (1).

PIN	4 μ s	3 μ s	2 μ s	1 μ s	OFF
TDT1	1	1	0	0	X
TDT2	1	0	1	0	X
SEL	1	1	1	1	0

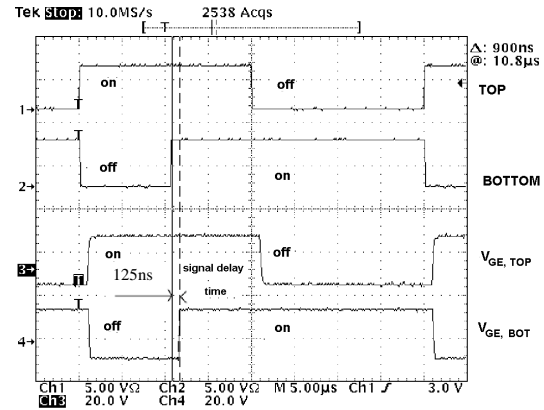

Fig. 4 Interlock function not active

Shortpulse suppression

A very short pulse can be suppressed by limiting the control input current. Thus with a 4.75k Ω resistance shorter pulse than 70ns can be suppressed. This gives a higher noise immunity.

DC-DC-Converter-Control signals

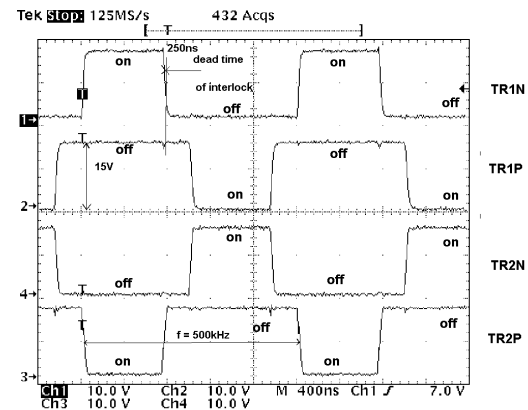

Fig. 5 output driver signals of the dc/dc converter.

The interlock time is 250ns, the frequency is 500kHz.

This technical information specifies devices but promises no characteristics. No warranty or guarantee expressed or implied is made regarding delivery, performance or suitability.