

EMG 12-B2 - Electronic housing



2948306

<https://www.phoenixcontact.com/us/products/2948306>

Please be informed that the data shown in this PDF document is generated from our Online Catalog. Please find the complete data in the user documentation. Our General Terms of Use for Downloads are valid.

Custom circuit module, consisting of housing, MKDS 3 connection terminal blocks and PCB



Commercial Data

Item number	2948306
Packing unit	1 pc
Minimum order quantity	1 pc
Sales Key	AC11
Product Key	ACHCBA
Catalog Page	Page 709 (C-1-2013)
GTIN	4017918083250
Weight per Piece (including packing)	27.19 g
Weight per Piece (excluding packing)	27.19 g
Customs tariff number	85369010
Country of origin	DE

EMG 12-B2 - Electronic housing

2948306

<https://www.phoenixcontact.com/us/products/2948306>

Technical Data

Product properties

Type	Lower housing part, removable cover as option, connection system integrated, PCB integrated
Product type	Stackable housing set
Product family	EMG
Number of positions	4
Pitch	5 mm
Type	Lower and upper part with universal foot, with PCB and solder tags that are led to the MKDS 3/... connection terminal blocks
Housing type	Component housing
Housing series	EMG

Dimensions

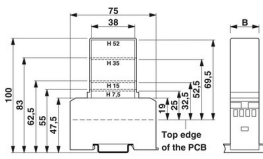
Dimensional drawing	
Width	12.5 mm
Installed height	47.5 mm
Height NS 35/7,5	55 mm 100 mm
Depth	75 mm
Length	75 mm
Pitch	5 mm

Material specifications

Color	green
Flammability rating according to UL 94	V0
Surface characteristics	untreated
Housing material	Polycarbonate, glass-fiber-reinforced

Environmental and real-life conditions

Ambient conditions

Degree of protection	IP20
Ambient temperature (operation)	-40 °C ... 125 °C

Mounting

Mounting type	DIN rail mounting
---------------	-------------------

EMG 12-B2 - Electronic housing

2948306

<https://www.phoenixcontact.com/us/products/2948306>

Drawings

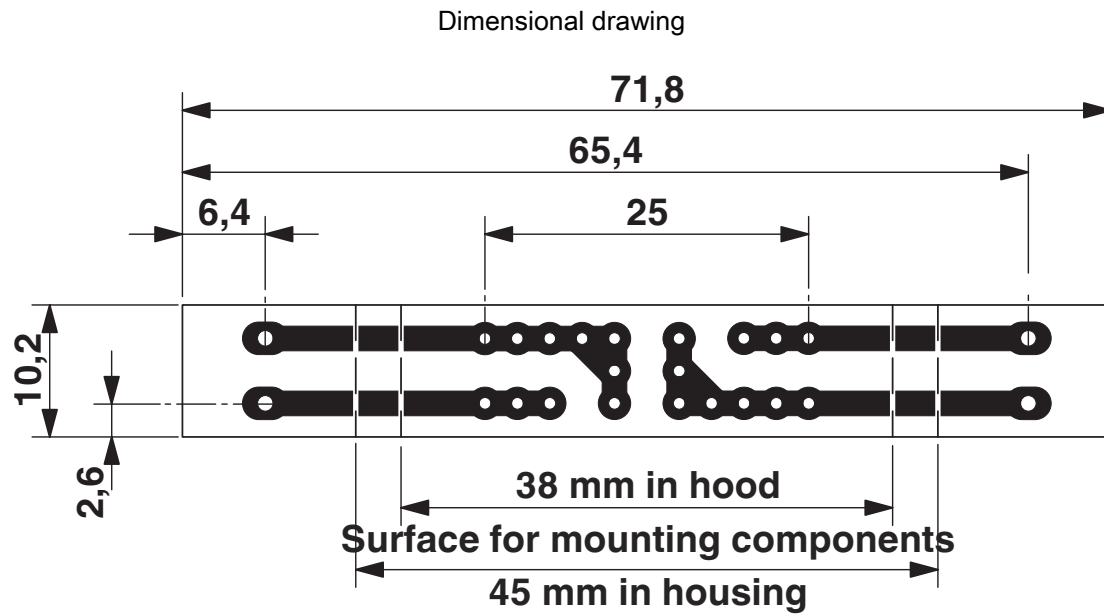

Pitch 5 mm

a = Area for mounting components, 38 mm in the hood

b = Area for mounting components, 45 mm in the housing

EMG 12-B2 - Electronic housing

2948306

<https://www.phoenixcontact.com/us/products/2948306>



Dimensional drawing

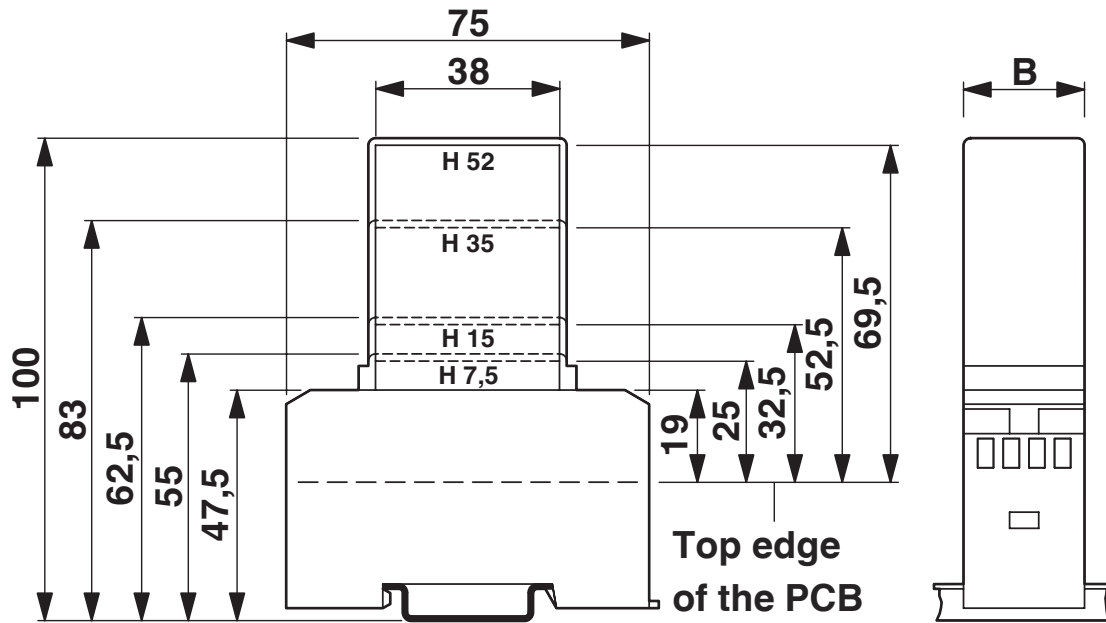

1 = Top edge of the PCB

B = Housing width

EMG 12-B2 - Electronic housing

2948306

<https://www.phoenixcontact.com/us/products/2948306>



Approvals



EAC

Approval ID: B.01687

EMG 12-B2 - Electronic housing

2948306

<https://www.phoenixcontact.com/us/products/2948306>



Classifications

ECLASS

ECLASS-10.0.1	27182702
ECLASS-11.0	27182702

ETIM

ETIM 8.0	EC001031
----------	----------

UNSPSC

UNSPSC 21.0	31261500
-------------	----------

EMG 12-B2 - Electronic housing

2948306

<https://www.phoenixcontact.com/us/products/2948306>



Environmental Product Compliance

REACH SVHC	Lead 7439-92-1
China RoHS	Environmentally Friendly Use Period = 50 years
	For information on hazardous substances, refer to the manufacturer's declaration available under "Downloads"

EMG 12-B2 - Electronic housing

2948306

<https://www.phoenixcontact.com/us/products/2948306>



Mandatory Accessories

EMG 12-H 7,5MM KLAR - Covering hood

2947116

<https://www.phoenixcontact.com/us/products/2947116>

Covering hood, for the contact and dust-protected encapsulation of the components, in transparent design. Height: 7.5 mm, width: 12.5 mm



EMG 12-H 15MM KLAR - Covering hood

2948296

<https://www.phoenixcontact.com/us/products/2948296>

Covering hood, for the contact and dust-protected encapsulation of the components, in transparent design. Height: 15 mm, width: 12.5 mm



EMG 12-B2 - Electronic housing

2948306

<https://www.phoenixcontact.com/us/products/2948306>



EMG 12-H 52MM GN - Covering hood

2947129

<https://www.phoenixcontact.com/us/products/2947129>



Covering hood, for the contact and dust-protected encapsulation of the components, in green design. Height: 52 mm, width: 12.5 mm

Accessories

EMG-KA - Cover

2941510

<https://www.phoenixcontact.com/us/products/2941510>



Terminal block/screw cover, set consisting of 50 strips each for terminal blocks and screw openings, 1 strip covers 12 terminal points.

EMG 12-B2 - Electronic housing

2948306

<https://www.phoenixcontact.com/us/products/2948306>



EMG-GKS 12 - Marking material

2947035

<https://www.phoenixcontact.com/us/products/2947035>



Device marking label, width: 12 mm, area: 12 x 8 mm, e.g. for EML(10x7) R adhesive marking material

Phoenix Contact 2023 © - all rights reserved

<https://www.phoenixcontact.com>

Phoenix Contact USA
586 Fulling Mill Road
Middletown, PA 17057, United States
(+717) 944-1300
info@phoenixcon.com