

Ordering Code:

CU30 24 P * A H L R 00* -NH
 ① ② ③ ④ ⑤ ⑥ ⑦ ⑧ ⑨ ⑩

- ① Series No.
- ② No. of Circuits
- ③ P=Plug
- ④ Plating option:
 A= Gold Flash plated on Contact area,
 Matte Tin plated on Solder tails,
 Nickel underplating over all.
 B= 15u" gold plated on Contact area,
 Matte Tin plated on Solder tails,
 Nickel underplating over all.
 C= 30u" gold plated on Contact area,
 Matte Tin plated on Solder tails,
 Nickel underplating over all.
- ⑤ Shell Material & Plating:
 A= Stainless Steel Nickel Plating
- ⑥ Contact Material: H= Copper Alloy
- ⑦ Insulator Material & Color option:
 L= LCP, Black
- ⑧ Packing R= Tape & Reel
- ⑨ 003= Without cover
 004= With cover
 006= With cover attach Back shell
- ⑩ NH= For Lead Free wave or IR Reflow Processes & Halogen Free

MATERIAL:

- 1.HOUSING: LCP, GLASS FIBER FILLED, BK
- 2.CONTACT: COPPER ALLOY
- 3.GUARD PLATE: STAINLESS STEEL,
- 4.SHELL: STAINLESS STEEL

FINISH:

- CONTACT :SEE ORDER INFORMATION.
- SHELL: NICKEL PLATING

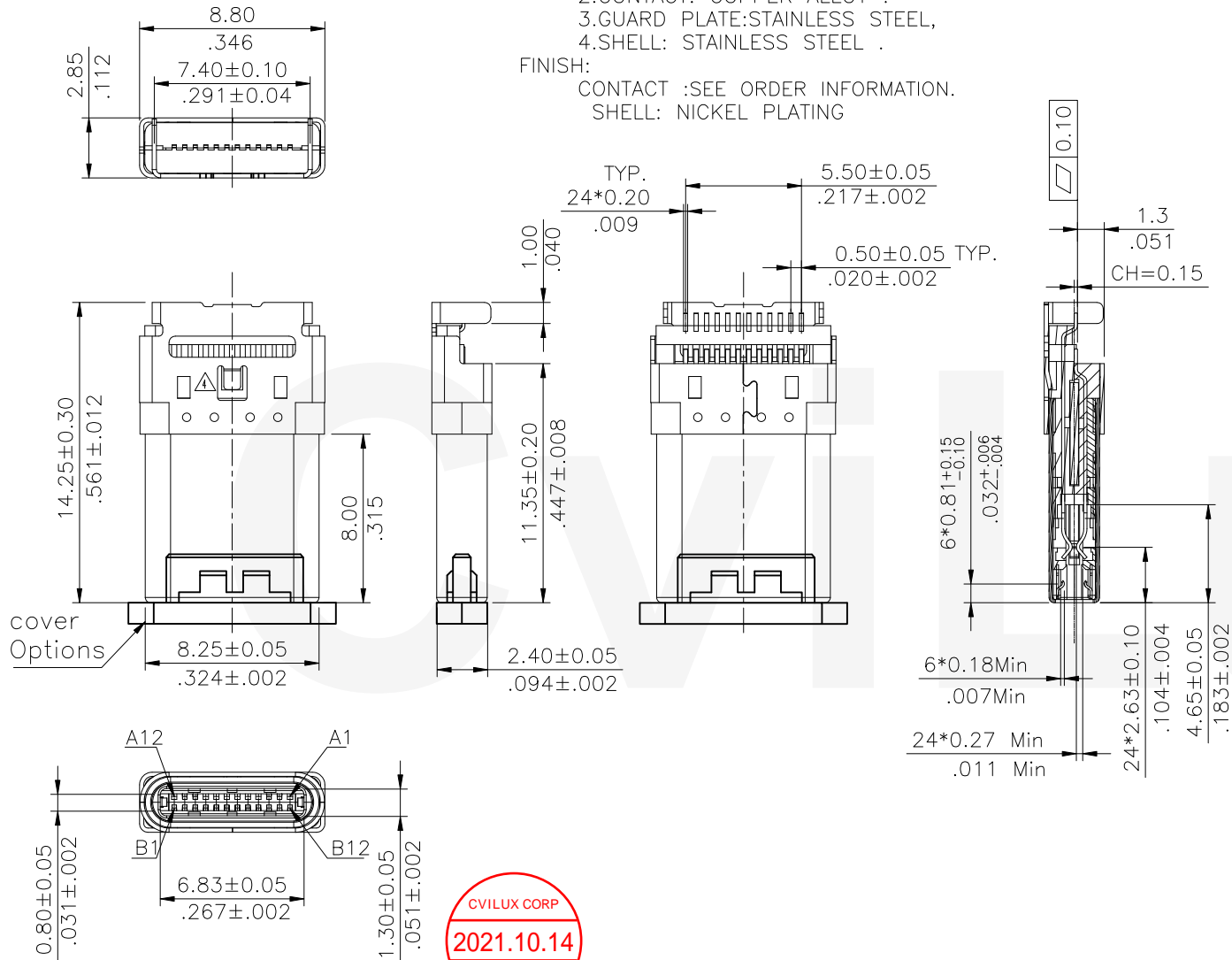

Lead Free Process Halogen-Free

4	Keny	09/28-21'	CHANGE ECRD121048		DATE	UNIT: mm / inch	TITLE:	 瀚荃股份有限公司 CviLux Corporation
3	Keny	7.25	CHANGE	DRAWN BY:	Annie	10/6-21'	CU30 Type C PLUG 24Pin CH=0.15 SMT Type MIDDLE MOUNT RIGHT ANGLE	
2	Annie	7.20	CHANGE ECND121024	ENGINEER:	Annie	10/6-21'	MATERIAL:	DRAWING NO. CU30P02SD PART NO. CU3024P*AHLR00*-NH SCALE 3 / 1 SHEET 1 OF 4
1	Keny	6.3	ECRD120018	CHECKED BY:	Keny	10/6-21'	FINISH:	
SYM	NAME	DATE	REVISIONS	APPROVED BY:	Keny	10/6-21'		

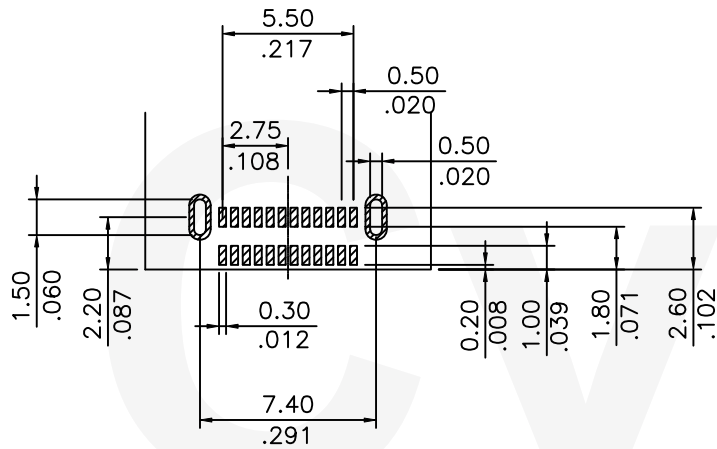
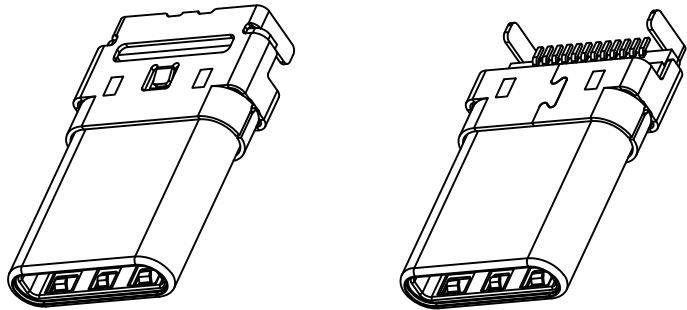

RECOMMENDED P.C.B. LAYOUT
 T=0.80(.031) OR 1.00(.040)mm
 TOLERANCE UNSPECIFIED ±0.05mm

USB TYPE-C FULL-FEATURED RECEPTACLE INTERFACE PIN ASSIGNMENTS

PIN	Signal Name	Description	PIN	Signal Name	Description
A1	GND	Ground return	B12	GND	Ground return
A2	SSTXp1	Positive half of first SuperSpeed TX differential pair	B11	SSRXp1	Positive half of first SuperSpeed RX differential pair
A3	SSTXn1	Negative half of first SuperSpeed TX differential pair	B10	SSRXn1	Negative half of first SuperSpeed RX differential pair
A4	Vbus	Bus Power	B9	VBUS	Bus Power
A5	CC1	Configuration Channel	B8	SBU2	Sideband Use(SBU)
A6	Dp1	Positive half of the USB 2.0 differential pair-Position 1	B7	Dn2	Negative half of the USB 2.0 differential pair-Position 2
A7	Dn1	Negative half of the USB 2.0 differential pair-Position 1	B6	Dp2	Positive half of the USB 2.0 differential pair-Position 2
A8	SBU1	Sideband Use(SBU)	B5	CC2	Configuration Channel
A9	VBUS	Bus Power	B4	VBUS	Bus Power
A10	SSRXn2	Negative half of second SuperSpeed RX differential pair	B3	SSTXn2	Negative half of second SuperSpeed TX differential pair
A11	SSRXp2	Positive half of second SuperSpeed RX differential pair	B2	SSTXp2	Positive half of second SuperSpeed TX differential pair
A12	GND	Ground return	B1	GND	Ground return



Lead Free Process Halogen-Free

SYM	NAME	DATE	REVISIONS	APPROVED BY:	Keny	10/6-21'	UNIT: mm / inch	TITLE:	 瀚荃股份有限公司 CviLux Corporation
4	Keny	09/28-21'	CHANGE ECRD121048				TOLERANCE UNLESS OTHERWISE SPECIFIED	CU30 Type C PLUG 24Pin CH=0.15 SMT Type MIDDLE MOUNT RIGHT ANGLE	
3	Keny	7.25	CHANGE	DRAWN BY:	Annie	10/6-21'			
2	Annie	7.20	CHANGE ECND121024	ENGINEER:	Annie	10/6-21'	.X ± 0.25/.010	.X" ± 4"	
1	Keny	6.3	ECRD120018	CHECKED BY:	Keny	10/6-21'	.XX ± 0.20/.008	.X" ± 2"	
				APPROVED BY:	Keny	10/6-21'	.XXX ± 0.10/.004	.XX" ± 1"	
								MATERIAL:	
								FINISH:	
								DRAWING NO. CU30P02SD	
								PART NO. CU3024P*AHLR00*-NH	
								SCALE 3 / 1	
								SHEET 2 OF 4	

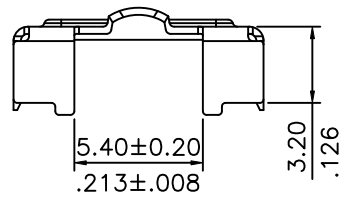
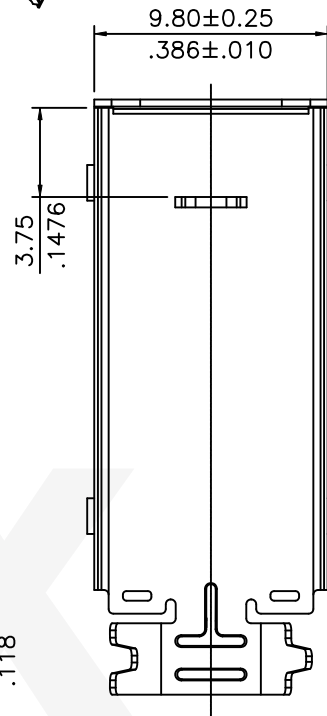
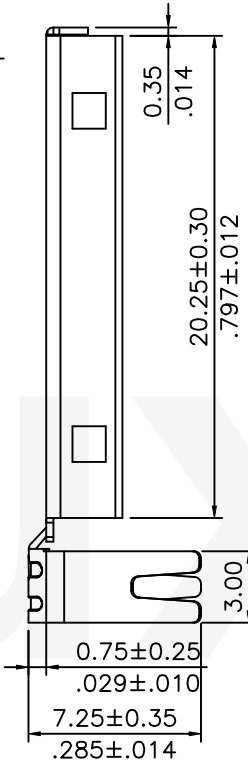
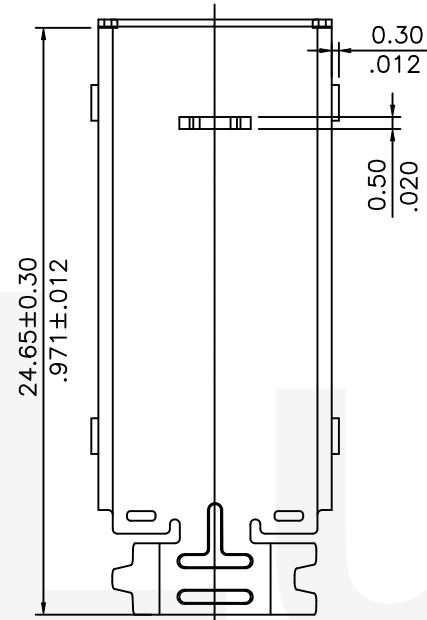
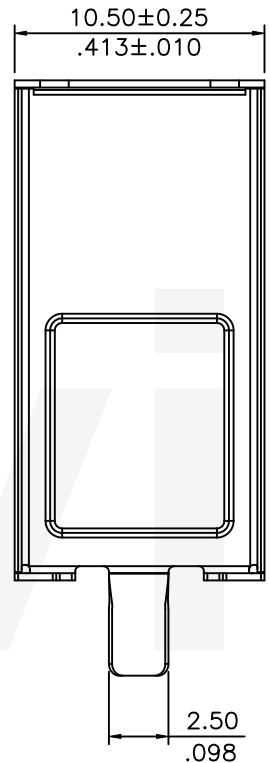
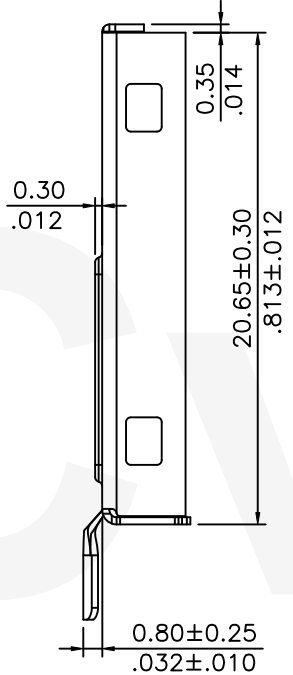
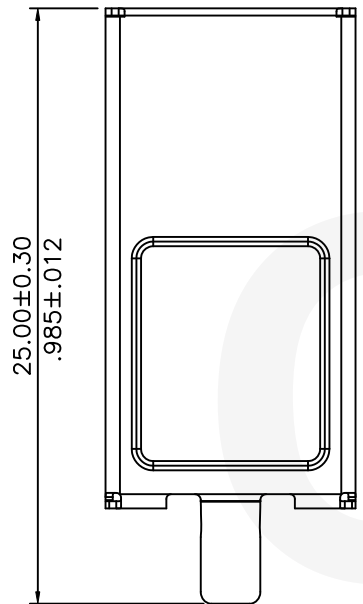
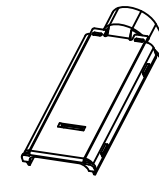
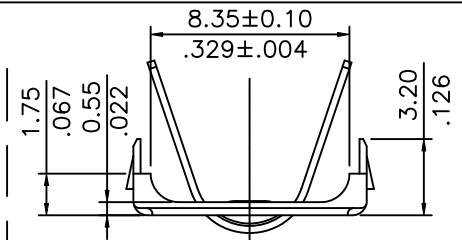
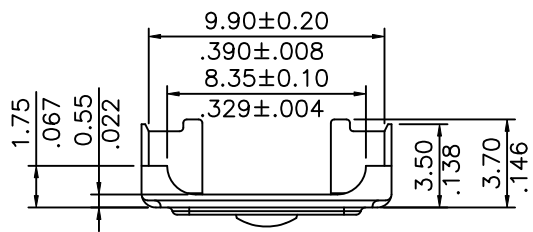

CIVILUX CORP
2021.10.14
ISSUED

attach Back shell

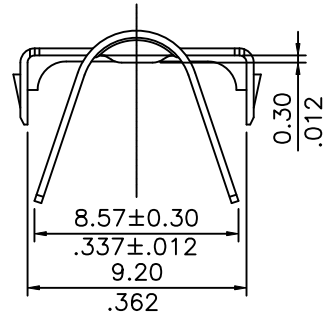

attach Back shell

Lead Free Process **Halogen-Free**

4	Keny	09/28-21'	CHANGE ECRD121048		DATE	UNIT: mm / inch	TITLE:
3	Keny	7.25	CHANGE	DRAWN BY: Annie	10/6-21'	TOLERANCE UNLESS OTHERWISE SPECIFIED	CU30 Type C PLUG 24Pin CH=0.15 SMT Type MIDDLE MOUNT RIGHT ANGLE
2	Annie	7.20	CHANGE ECND121024	ENGINEER: Annie	10/6-21'		MATERIAL:
1	Keny	6.3	ECRD120018	CHECKED BY: Keny	10/6-21'		FINISH:
SYM	NAME	DATE	REVISIONS	APPROVED BY: Keny	10/6-21'	.X ± 0.25/.010 X' ± 4"	
						.XX ± 0.20/.008 X" ± 2"	
						.XXX ± 0.10/.004 .XX' ± 1"	

 瀚荃股份有限公司
CviLux Corporation

DRAWING NO.	CU30P02SD	PART NO.	CU3024P*AHLR00*-NH
SCALE	3 / 1	SHEET	3 OF 4

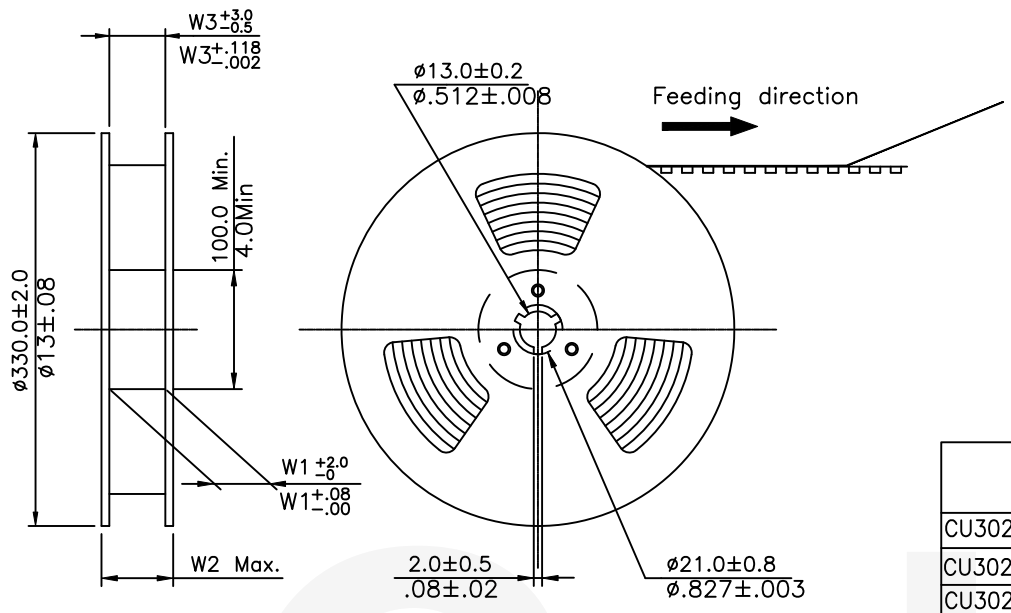

NOTE :

- * Reel Material : HIPS
- * Carrier Material : Black, Conductive Polystyrene Alloy
- * Cover Tape Material : Polyester
- * Cover Tape Peel Strength : 0.1N – 1.3N
- * Carrier camber is within 1mm in 250mm
- * All dimensions meet EIA-481-B requirements.
- * Quantity : 1000 PCS/Reel

PART NO.	Dimension				Packing (Reel/Carton)
	E	W1	W2	W3	
CU3024P*AHLR003-NH	24.0(.945)	24.5(.965)	30.5(1.201)	24.5(.965)	10
CU3024P*AHLR004-NH	32.0(1.260)	32.5(1.279)	36.5(1.437)	32.5(1.279)	8
CU3024P*AHLR006-NH	32.0(1.260)	32.5(1.279)	36.5(1.437)	32.5(1.279)	8

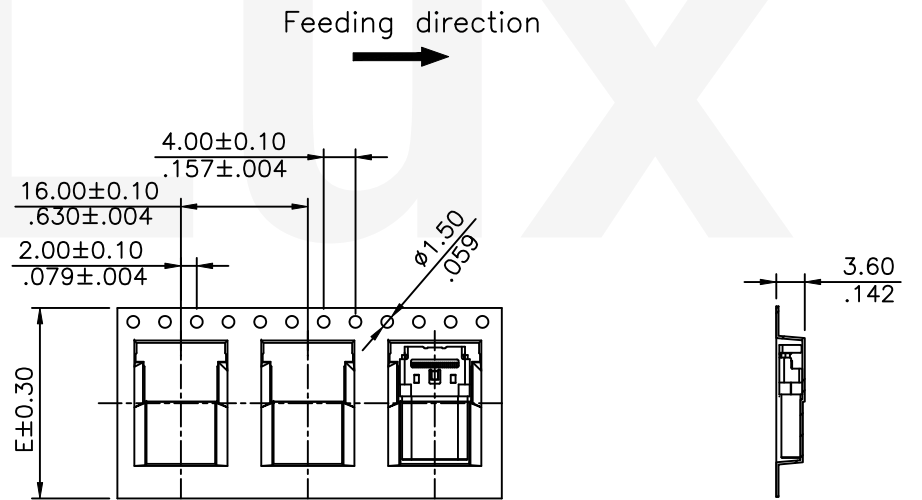
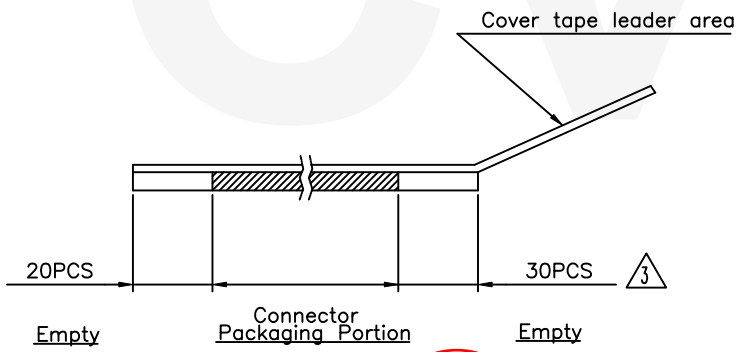

WIDTH : 24 mm Carrier

Lead Free Process Halogen-Free

CVILUX CORP
2021.10.14
ISSUED

SYM	NAME	DATE	REVISIONS	APPROVED BY:	Keny	10/6-21'	UNIT: mm / inch	TOLERANCE UNLESS OTHERWISE SPECIFIED	MATERIAL:	FINISH:
4	Keny	09/28-21'	CHANGE ECRD121048	DATE						
3	Keny	7.25	CHANGE	DRAWN BY:	Annie	10/6-21'				
2	Annie	7.20	CHANGE ECND121024	ENGINEER:	Annie	10/6-21'	.X ±	X' ± 4'		
1	Keny	6.3	ECRD120018	CHECKED BY:	Keny	10/6-21'	.XX ±	.X' ± 2'		
				APPROVED BY:	Keny	10/6-21'	.XXX ±	.XX' ± 1'		

瀚荃股份有限公司
CviLux Corporation

DRAWING NO.	CU30P02SD	PART NO.	CU3024P*AHLR00*-NH
SCALE	3 / 1	SHEET	4 OF 4

TITLE:
 CU30 Type C PLUG 24Pin CH=0.15
 SMT Type MIDDLE MOUNT RIGHT ANGLE