

2SK2595

Silicon N-Channel MOS FET
UHF Power Amplifier

HITACHI

ADE-208-1366 (Z)

1st. Edition

Mar. 2001

Features

- High power output, High gain, High efficiency
PG = 7.8dB, Pout = 37.3dBm, $\eta_D = 50\%$ min. ($f = 836.5\text{MHz}$)
- Compact package capable of surface mounting

Outline

RP8P

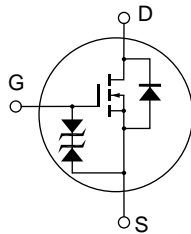
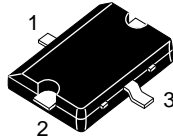

1. Gate
2. Source
3. Drain

This Device is sensitive to Electrostatic Discharge.

An Adequate handling procedure is requested.

Absolute Maximum Ratings (Ta = 25°C)

Item	Symbol	Ratings	Unit
Drain to source voltage	V _{DSS}	17	V
Gate to source voltage	V _{GSS}	±10	V
Drain current	I _D	1.1	A
Drain peak current	I _{D(pulse)} *1	5	A
Channel dissipation	Pch*2	20	W
Channel temperature	Tch	150	°C
Storage temperature	Tstg	-45 to +150	°C

Notes: 1. PW ≤ 10μs, duty cycle ≤ 1 %

2. Value at Tc = 25°C

Electrical Characteristics (Ta = 25°C)

Item	Symbol	Min.	Typ	Max.	Unit	Test Conditions
Zero gate voltage drain current	I _{DSS}	—	—	10	μA	V _{DS} = 12 V, V _{GS} = 0
Gate to source leak current	I _{GSS}	—	—	±5.0	μA	V _{GS} = ±10V, V _{DS} = 0
Gate to source cutoff voltage	V _{GS(off)}	0.6	—	1.3	V	I _D = 6mA, V _{DS} = 12V
Input capacitance	Ciss	—	68	—	pF	V _{GS} = 5V, V _{DS} = 0 f = 1MHz
Output capacitance	Coss	—	27	—	pF	V _{DS} = 12V, V _{GS} = 0 f = 1MHz
Output Power	Pout	37.3	38.45	—	dBm	V _{DS} = 12V, f = 836.5MHz Pin = 29.5dBm
Drain Rational	ηD	50	60	—	%	V _{DS} = 12V Pout = 37.3dBm f = 836.5MHz Pin = 29.5dBm

Main Characteristics

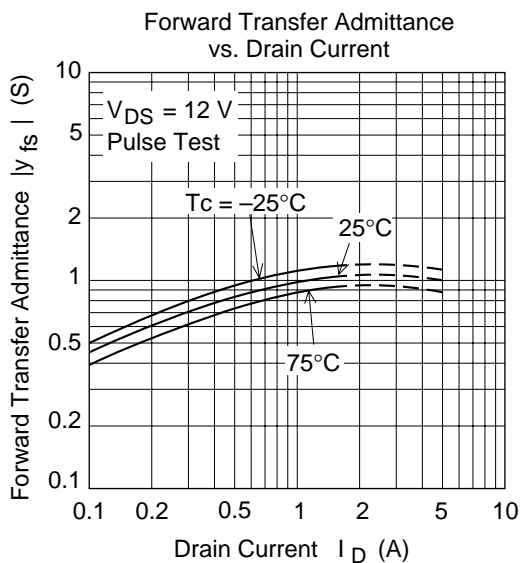
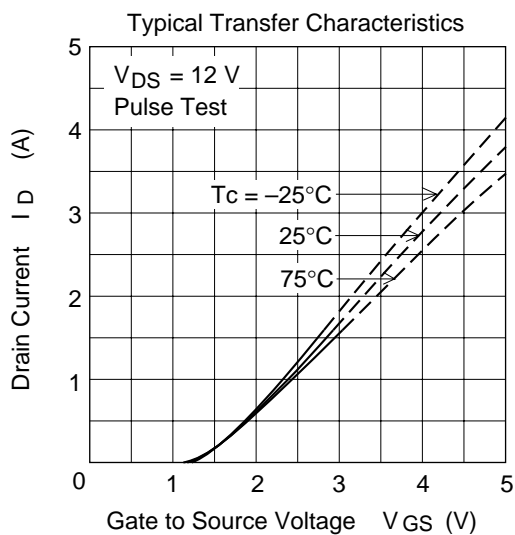
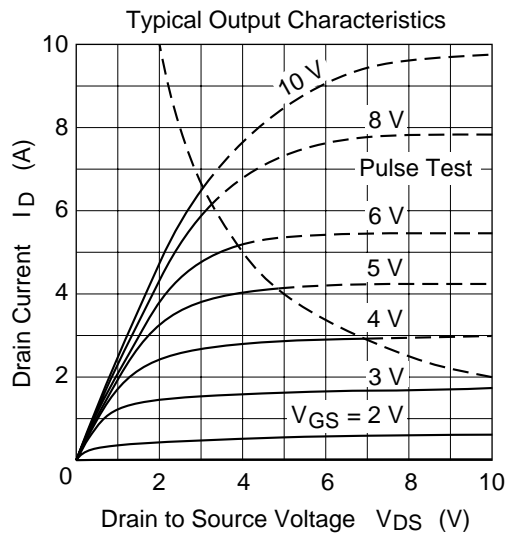
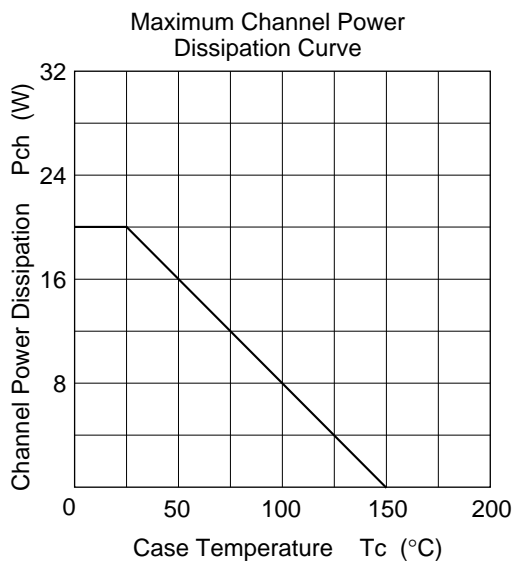

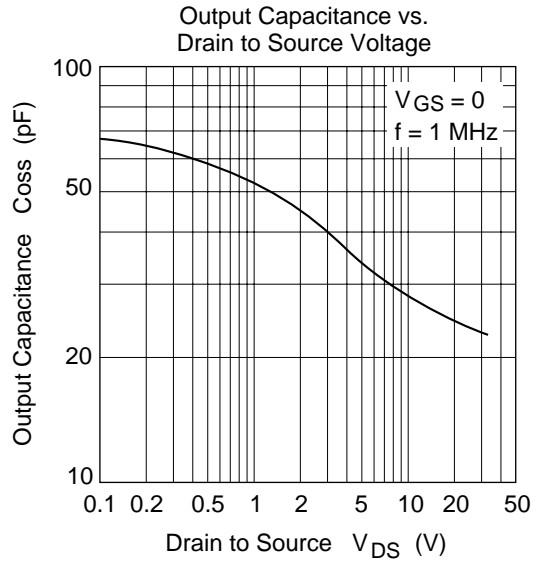
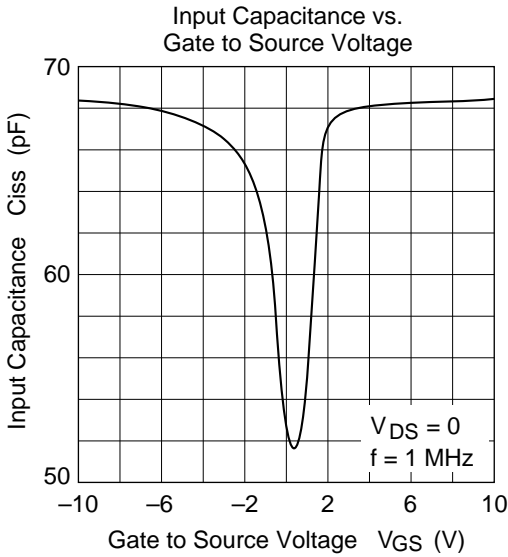
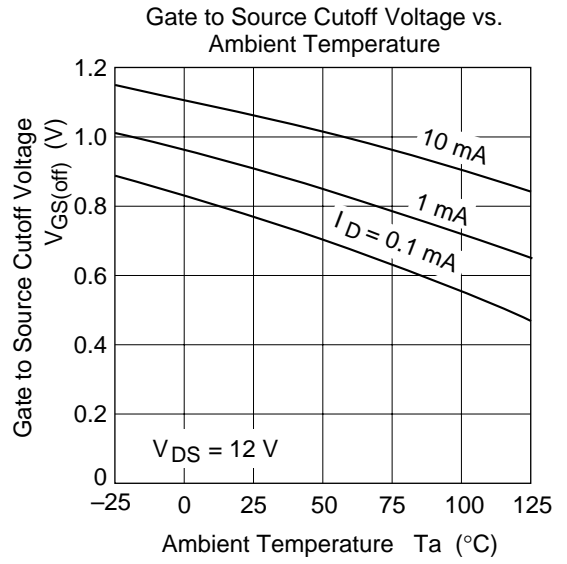
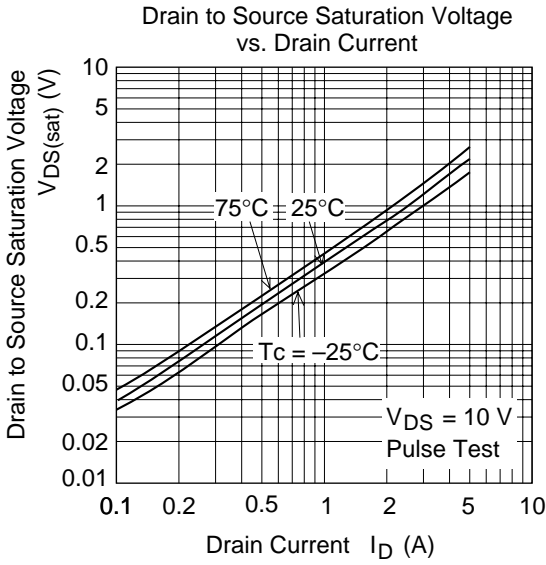

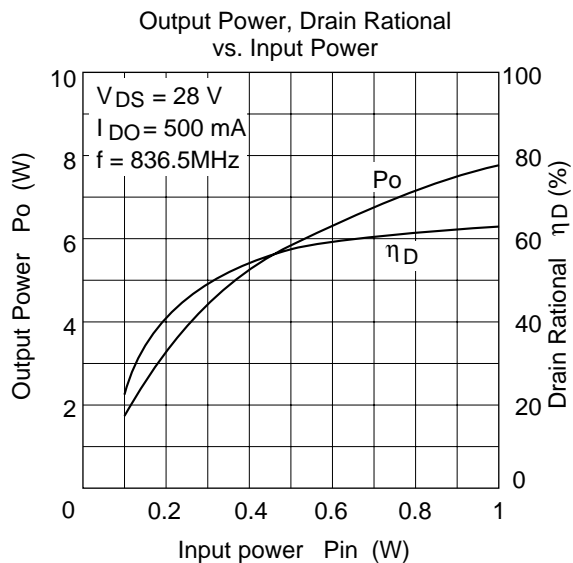
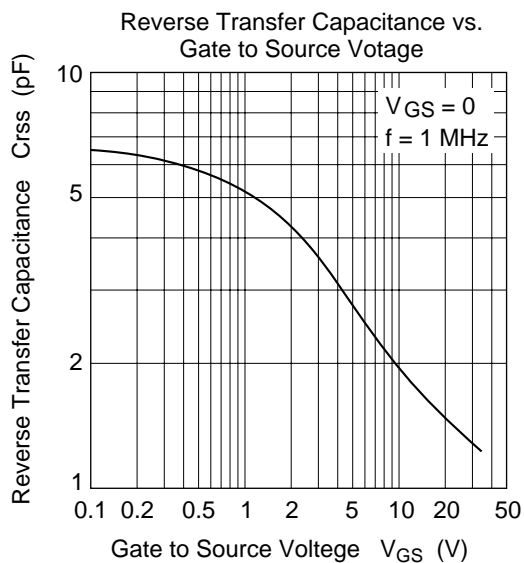

Package Dimensions

As of January, 2001

Unit: mm

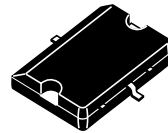
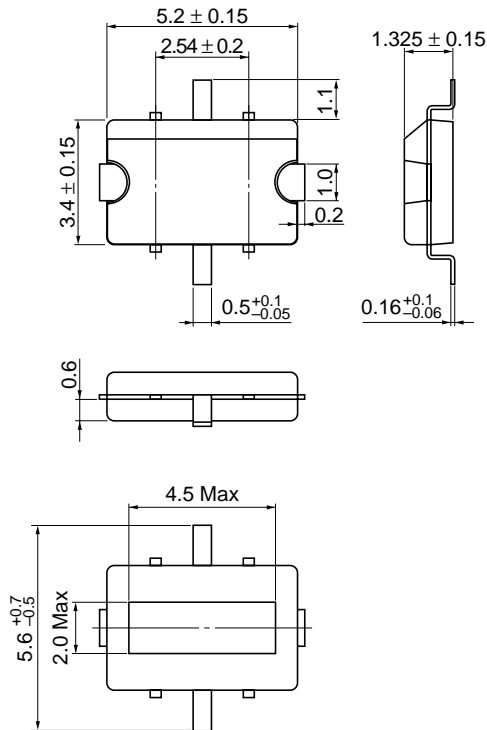

Hitachi Code	RP8P
JEDEC	—
EIAJ	—
Mass (reference value)	0.08 g

Cautions

1. Hitachi neither warrants nor grants licenses of any rights of Hitachi's or any third party's patent, copyright, trademark, or other intellectual property rights for information contained in this document. Hitachi bears no responsibility for problems that may arise with third party's rights, including intellectual property rights, in connection with use of the information contained in this document.
2. Products and product specifications may be subject to change without notice. Confirm that you have received the latest product standards or specifications before final design, purchase or use.
3. Hitachi makes every attempt to ensure that its products are of high quality and reliability. However, contact Hitachi's sales office before using the product in an application that demands especially high quality and reliability or where its failure or malfunction may directly threaten human life or cause risk of bodily injury, such as aerospace, aeronautics, nuclear power, combustion control, transportation, traffic, safety equipment or medical equipment for life support.
4. Design your application so that the product is used within the ranges guaranteed by Hitachi particularly for maximum rating, operating supply voltage range, heat radiation characteristics, installation conditions and other characteristics. Hitachi bears no responsibility for failure or damage when used beyond the guaranteed ranges. Even within the guaranteed ranges, consider normally foreseeable failure rates or failure modes in semiconductor devices and employ systemic measures such as fail-safes, so that the equipment incorporating Hitachi product does not cause bodily injury, fire or other consequential damage due to operation of the Hitachi product.
5. This product is not designed to be radiation resistant.
6. No one is permitted to reproduce or duplicate, in any form, the whole or part of this document without written approval from Hitachi.
7. Contact Hitachi's sales office for any questions regarding this document or Hitachi semiconductor products.

HITACHI

Hitachi, Ltd.

Semiconductor & Integrated Circuits.
Nippon Bldg., 2-6-2, Ohte-machi, Chiyoda-ku, Tokyo 100-0004, Japan
Tel: Tokyo (03) 3270-2111 Fax: (03) 3270-5109

URL	NorthAmerica	: http://semiconductor.hitachi.com/
	Europe	: http://www.hitachi-eu.com/hel/ecg
	Asia	: http://sicapac.hitachi-asia.com
	Japan	: http://www.hitachi.co.jp/Sicd/indx.htm

For further information write to:

Hitachi Semiconductor
(America) Inc.
179 East Tasman Drive,
San Jose, CA 95134
Tel: <1> (408) 433-1990
Fax: <1> (408) 433-0223

Hitachi Europe GmbH
Electronic Components Group
Dornacher Straße 3
D-85622 Feldkirchen, Munich
Germany
Tel: <49> (89) 9 9180-0
Fax: <49> (89) 9 29 30 00

Hitachi Europe Ltd.
Electronic Components Group.
Whitebrook Park
Lower Cookham Road
Maidenhead
Berkshire SL6 8YA, United Kingdom
Tel: <44> (1628) 585000
Fax: <44> (1628) 585160

Hitachi Asia Ltd.
Hitachi Tower
16 Collyer Quay #20-00,
Singapore 049318
Tel : <65>-538-6533/538-8577
Fax : <65>-538-6933/538-3877
URL : <http://www.hitachi.com.sg>

Hitachi Asia Ltd.
(Taipei Branch Office)
4/F, No. 167, Tun Hwa North Road,
Hung-Kuo Building,
Taipei (105), Taiwan
Tel : <886>-(2)-2718-3666
Fax : <886>-(2)-2718-8180
Telex : 23222 HAS-TP
URL : <http://www.hitachi.com.tw>

Hitachi Asia (Hong Kong) Ltd.
Group III (Electronic Components)
7/F., North Tower,
World Finance Centre,
Harbour City, Canton Road
Tsim Sha Tsui, Kowloon,
Hong Kong
Tel : <852>-(2)-735-9218
Fax : <852>-(2)-730-0281
URL : <http://www.hitachi.com.hk>

Copyright © Hitachi, Ltd., 2000. All rights reserved. Printed in Japan.
Colophon 2.0