

MOS INTEGRATED CIRCUIT

μ PD166100, 166101

N-CHANNEL LOW SIDE INTELLIGENT POWER DEVICE

The μ PD166100, 166101 are N-channel Low-side Driver for Solenoids and Lamp Drivers. It build in protection functions.

FEATURES

- Built in current limit and thermal shutdown circuit. Thermal shutdown will automatically restart after the channel temperature has cool down.
- Low on-state resistance: $R_{DS(ON)} = 160 \text{ m}\Omega$ ($V_{IN} = 5 \text{ V}$, $I_{OUT} = 0.8 \text{ A}$, $T_{ch} = 25^\circ\text{C}$)
- Built in dynamic clamp circuit
- μ PD166101: Dual channel Low-side switch
- Small and surface mount package (8-pin SOP)

PACKAGE DRAWING (unit: mm)

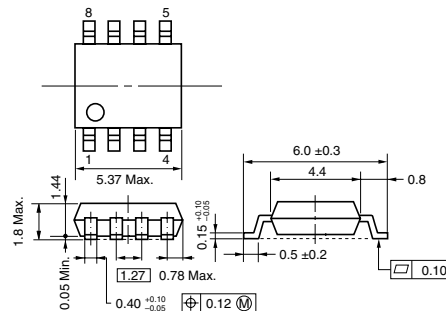

ORDERING INFORMATION

Part Number	Package
μ PD166100GR(20)	8-pin SOP
μ PD166101GR(20)	8-pin SOP

BLOCK DIAGRAM

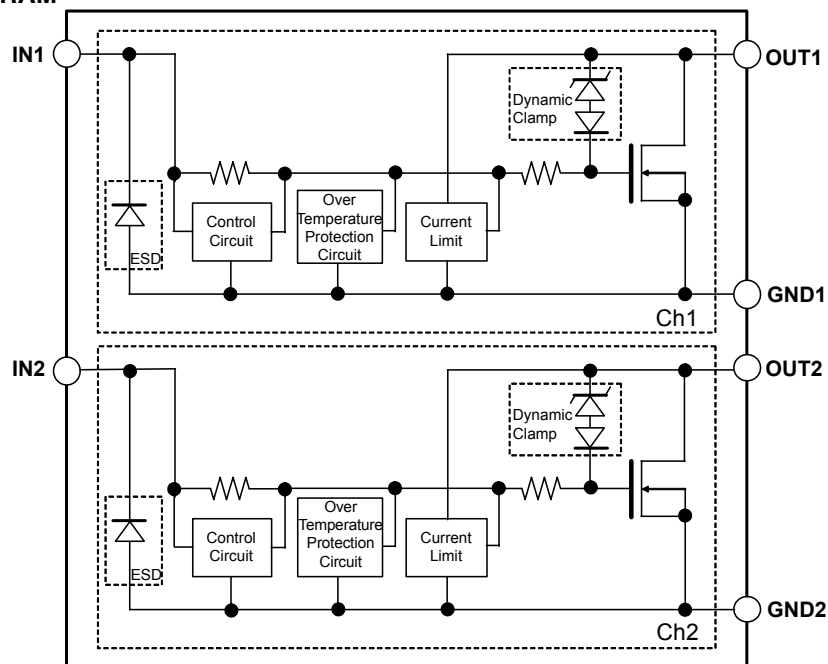

Remark μ PD166100: Ch1 only

The information in this document is subject to change without notice. Before using this document, please confirm that this is the latest version.
 Not all products and/or types are available in every country. Please check with an NEC Electronics sales representative for availability and additional information.

PIN CONFIGURATION (Top View)

- 8-pin SOP
 μPD166100GR (20), μPD166101GR (20)

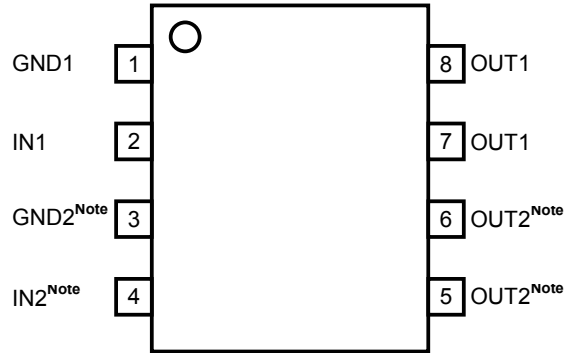

Pin No.	Symbol	Function
1	GND1	Connected to Ground
2	IN1	Input terminal1 (active level is high)
3	GND2 ^{Note}	Connected to Ground
4	IN2 ^{Note}	Input terminal2 (active level is high)
5	OUT2 ^{Note}	Output terminal2
6	OUT2 ^{Note}	Output terminal2
7	OUT1	Output terminal1
8	OUT1	Output terminal1

Note μPD166100: Pin No.3 to 6 are N.C.

ABSOLUTE MAXIMUM RATING (T_A = 25°C unless otherwise specified)

Parameter	Symbol	Conditions	Rating	Unit	
Output voltage	V _{OUT}	V _{IN} = 0 V, DC	40	V	
Input voltage	V _{IN}		7	V	
Negative input current	I _{IL}		-10	mA	
Output current	I _{OUT(DC)}	V _{IN} = 5 V	SELF LIMITED	A/UNIT	
Total power dissipation	P _D ^{Note}	μPD166100	On-State	1.5	W
		μPD166101	2ch On-State	2	
Channel temperature	T _{ch}		150	°C	
Storage temperature	T _{stg}		-55 to +150	°C	

Note Mounted on ceramic substrate of 20cm x 20cm x 1.1mm

ELECTRICAL CHARACTERISTICS (T_{ch} = 25°C unless otherwise specified)

Parameter	Symbol	Conditions	Min.	Typ.	Max.	Unit
Output clamping voltage	V _{OUT}	I _{OUT} = 1 mA, V _{IN} = 0 V	40		60	V
Output Off leakage current	I _{OL}	V _{IN} = V _{IL} , V _{OUT} = 18 V			100	μA
High Level Input current	I _{IH}	V _{IN} = 5.5 V, V _{OUT} = 0 V			300	μA
Low Level Input current	I _{IL}	V _{IN} = 0 V, V _{OUT} = 18 V	-10		10	μA
High Level Input voltage	V _{IH}	I _{OUT} = 0.8 A, V _{OUT} = 0.2 V	3			V
Low Level Input voltage	V _{IL}	V _{OUT} = 10 V, I _{OUT} = 1 mA			1.5	V
ON-state resistance	R _{DSON}	V _{IN} = 5 V, I _{OUT} = 0.8 A			160	mΩ
		V _{IN} = 3 V, I _{OUT} = 0.8 A			195	mΩ
Turn-on time	t _{on}	V _{CC} = 18 V, R _L = 22 Ω,			120	μs
Rise time	t _r	V _{IN} = 0 V to 5 V,			80	μs
Turn-off time	t _{off}	R _{IN} = 10 Ω			200	μs
Fall time	t _f				80	μs
Thermal shutdown detection temperature ^{Note}	T _{HI}	V _{IN} = 5 V	150			°C
Current limit	I _S	V _{IN} = 3 V	1			A
Input frequency	f _{IN}				1	kHz

Note The low side switch is shutdown if the channel temperature exceeds thermal shutdown temperature. It will automatically restart after the channel temperature has cooled down than thermal shutdown temperature.

TEST CIRCUIT

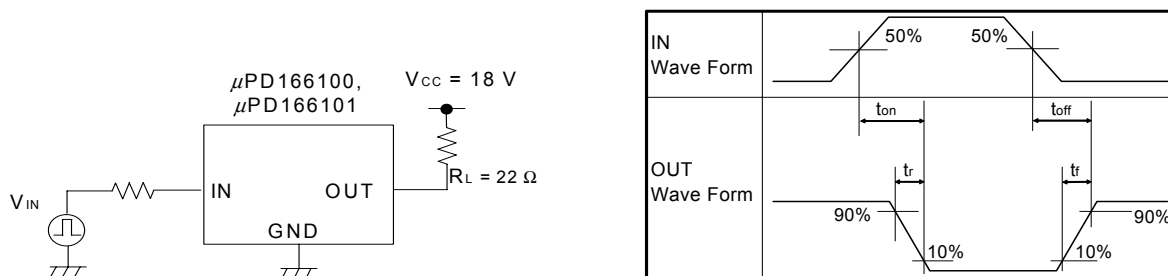

TYPICAL CHARACTERISTICS

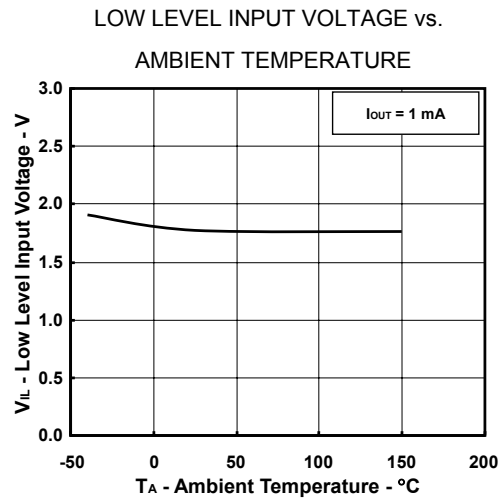
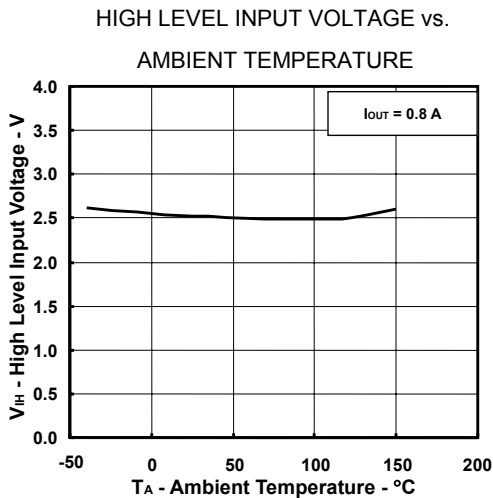
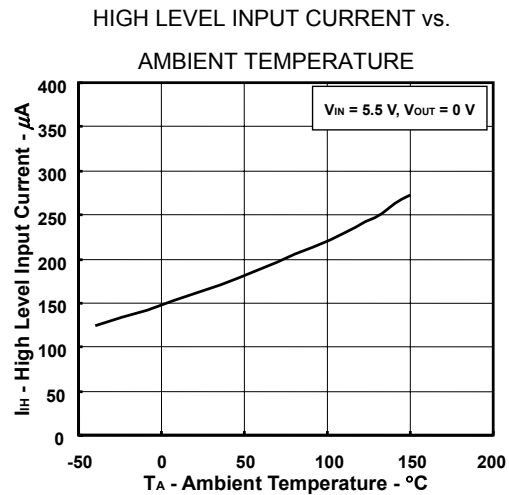
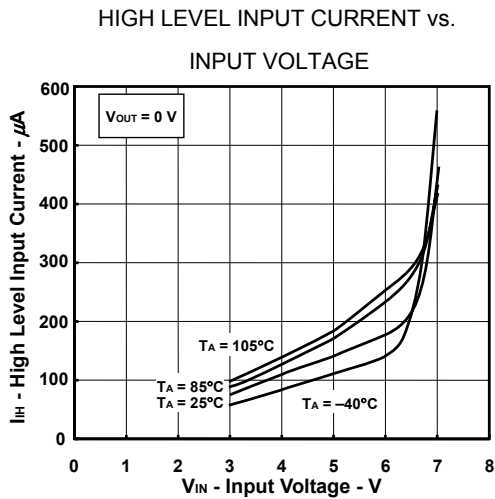
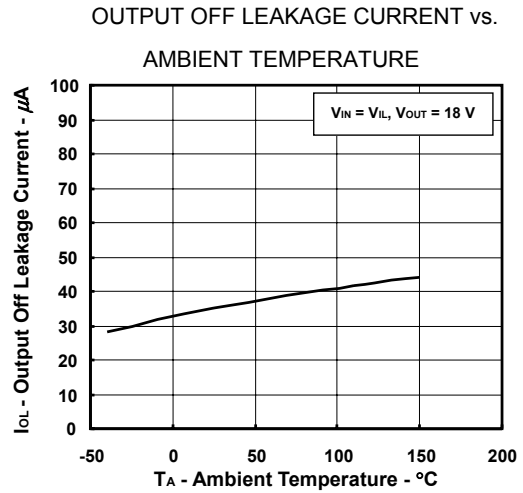
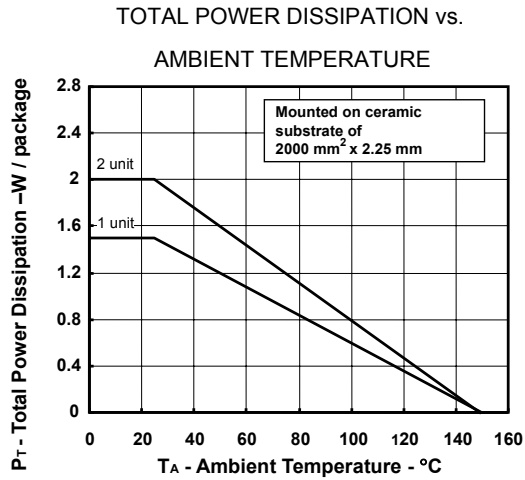

ON-STATE RESISTANCE vs.
OUTPUT CURRENT

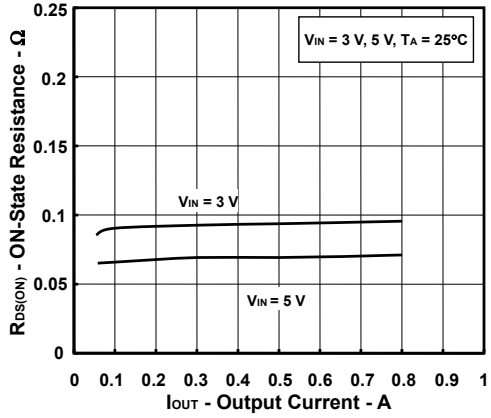

ON-STATE RESISTANCE vs.
AMBIENT TEMPERATURE

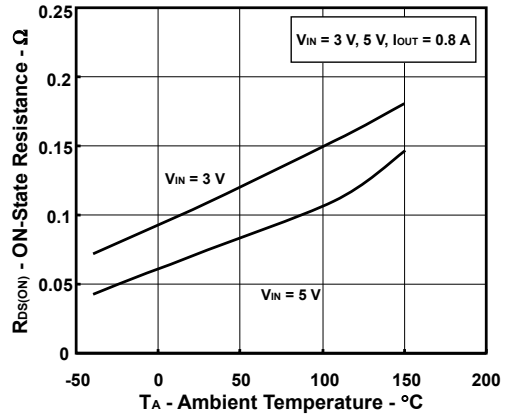

ON-STATE RESISTANCE vs.
INPUT VOLTAGE

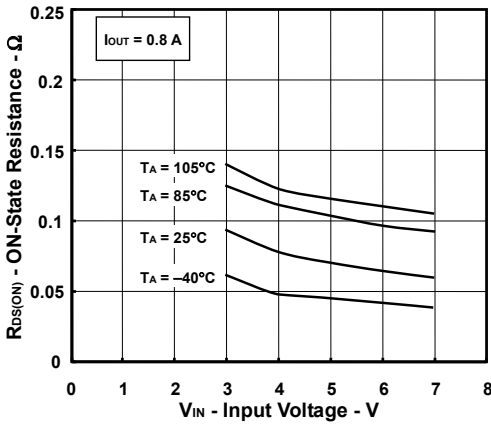

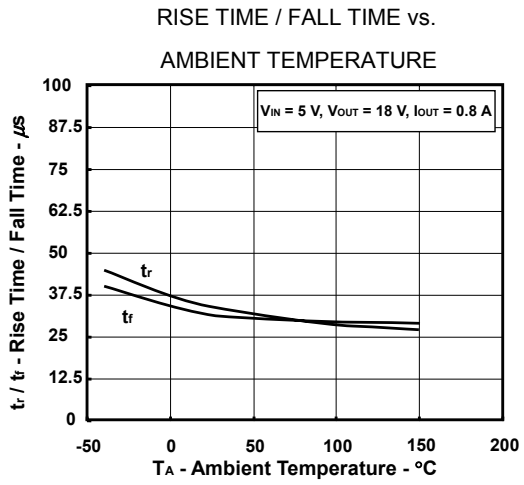
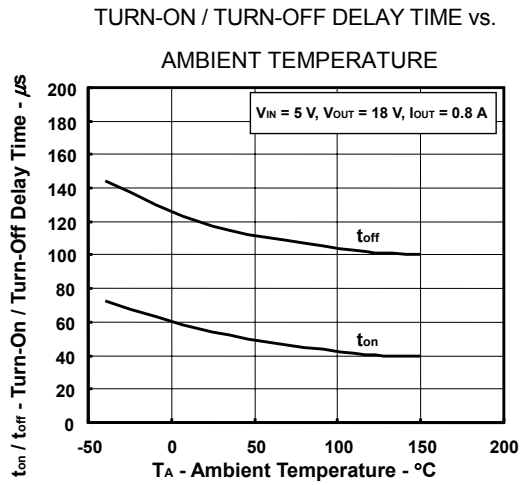
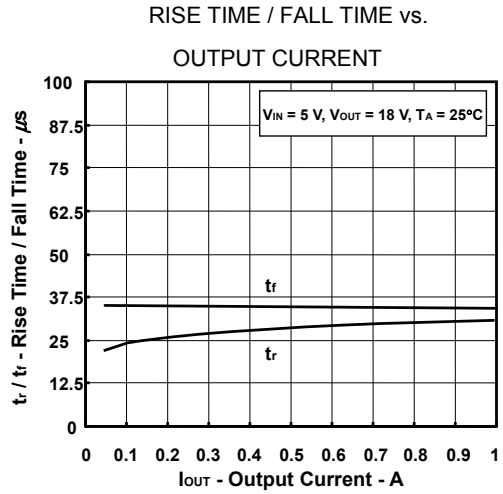
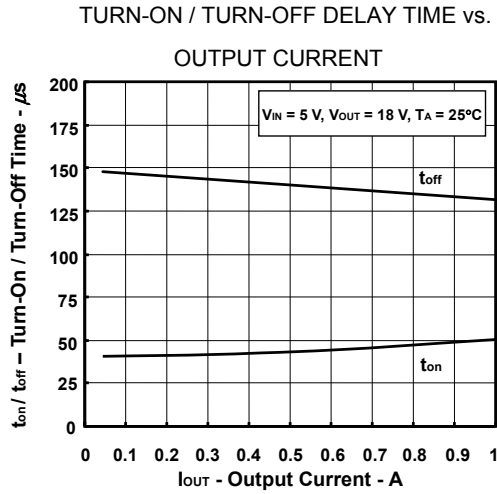

APPLICATION CIRCUIT EXAMPLE

(1) Inductance load

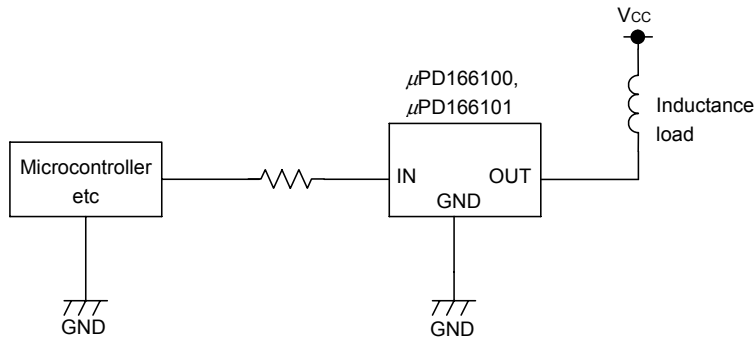

(2) Lamp load

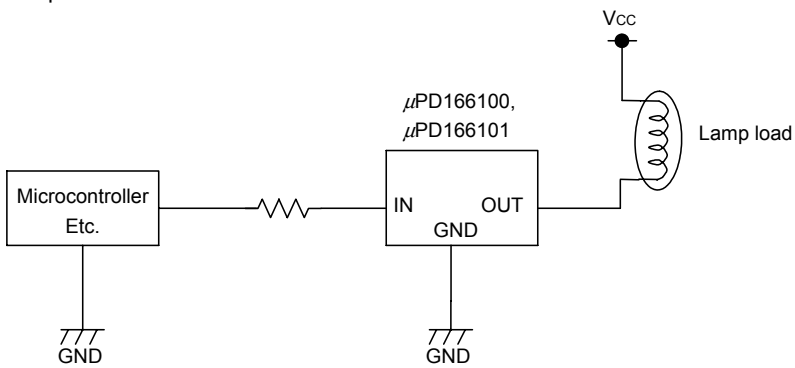

Caution This circuit diagram is a connection example, and it is not the one to mass-produce it.

RECOMMENDED SOLDERING CONDITIONS

When soldering this product, it is highly recommended to observe the conditions as shown below.

If other soldering processes are used, or if the soldering is performed under different conditions, please make sure to consult with our sales offices.

μPD166100 GR (20): 8-pin SOP

μPD166101 GR (20): 8-pin SOP

Soldering method	Soldering conditions	Symbol
Infrared ray reflow	Peak temperature of package surface: 260°C, Time: 30 seconds max (210 °C min.), Number of reflow process: 3	IR60-00-3
Partial heating method	Pin temperature: 300°C max, Heat time: 3 seconds max (per pin)	-

[MEMO]

[MEMO]

[MEMO]

- **The information in this document is current as of March, 2005. The information is subject to change without notice. For actual design-in, refer to the latest publications of NEC Electronics data sheets or data books, etc., for the most up-to-date specifications of NEC Electronics products. Not all products and/or types are available in every country. Please check with an NEC Electronics sales representative for availability and additional information.**
- No part of this document may be copied or reproduced in any form or by any means without the prior written consent of NEC Electronics. NEC Electronics assumes no responsibility for any errors that may appear in this document.
- NEC Electronics does not assume any liability for infringement of patents, copyrights or other intellectual property rights of third parties by or arising from the use of NEC Electronics products listed in this document or any other liability arising from the use of such products. No license, express, implied or otherwise, is granted under any patents, copyrights or other intellectual property rights of NEC Electronics or others.
- Descriptions of circuits, software and other related information in this document are provided for illustrative purposes in semiconductor product operation and application examples. The incorporation of these circuits, software and information in the design of a customer's equipment shall be done under the full responsibility of the customer. NEC Electronics assumes no responsibility for any losses incurred by customers or third parties arising from the use of these circuits, software and information.
- While NEC Electronics endeavors to enhance the quality, reliability and safety of NEC Electronics products, customers agree and acknowledge that the possibility of defects thereof cannot be eliminated entirely. To minimize risks of damage to property or injury (including death) to persons arising from defects in NEC Electronics products, customers must incorporate sufficient safety measures in their design, such as redundancy, fire-containment and anti-failure features.
- NEC Electronics products are classified into the following three quality grades: "Standard", "Special" and "Specific".

The "Specific" quality grade applies only to NEC Electronics products developed based on a customer-designated "quality assurance program" for a specific application. The recommended applications of an NEC Electronics product depend on its quality grade, as indicated below. Customers must check the quality grade of each NEC Electronics product before using it in a particular application.

"Standard": Computers, office equipment, communications equipment, test and measurement equipment, audio and visual equipment, home electronic appliances, machine tools, personal electronic equipment and industrial robots.

"Special": Transportation equipment (automobiles, trains, ships, etc.), traffic control systems, anti-disaster systems, anti-crime systems, safety equipment and medical equipment (not specifically designed for life support).

"Specific": Aircraft, aerospace equipment, submersible repeaters, nuclear reactor control systems, life support systems and medical equipment for life support, etc.

The quality grade of NEC Electronics products is "Standard" unless otherwise expressly specified in NEC Electronics data sheets or data books, etc. If customers wish to use NEC Electronics products in applications not intended by NEC Electronics, they must contact an NEC Electronics sales representative in advance to determine NEC Electronics' willingness to support a given application.

(Note)

- (1) "NEC Electronics" as used in this statement means NEC Electronics Corporation and also includes its majority-owned subsidiaries.
- (2) "NEC Electronics products" means any product developed or manufactured by or for NEC Electronics (as defined above).