

Installation time relays

Electronic time relays from the BT product range offer ideal solutions for industrial applications.

The BT product range provides the following functions:

- Pick-up delay (BTR)
- Pulse emitter (BTTT)
- Multifunction (BTM)
- Multifunction (BTMF)
- Star-delta change-over

Time ranges and power supply for time relays

Using the central knob, you can select the functions of the modules precisely over either 4 or 8 time ranges.

The multi-voltage supply voltage range offers a wide bandwidth for industrial use (see table).

Time ranges

Display of time scale	Time range
0.1 s	0.1 to 1.2 s
1 s	1 to 12 s
0.1 min	0.1 to 1.2 min
1 min	1 to 12 min
0.1 h	0.1 to 1.2 h
1 h	1 to 12 h
10 h	10 to 120 h

Note:

If the rotary knob for time adjustment is set to "0", the output will be switched without delay.

Output of the time relays

In every module, a change-over contact (250 V, 8A) switches the load. The multifunction module (BTM) activates both change-over contacts immediately, or one change-over contact immediately and the second after a delay.

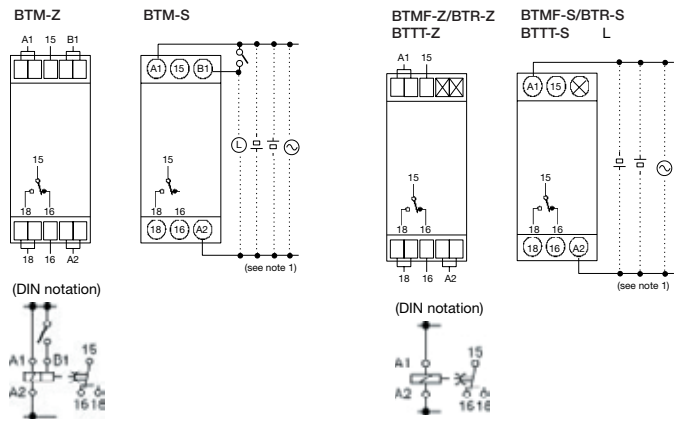

Note:

1. Pole numbers are not necessary for DC voltage supply.
2. The contact symbol of H3DS is marked with  as it provides several operating modes and differs from the delayed contacts of conventional time relays.

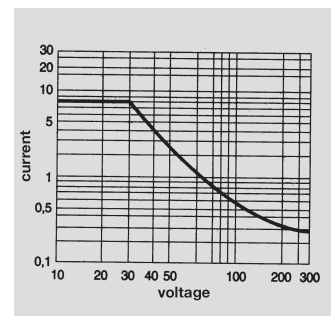
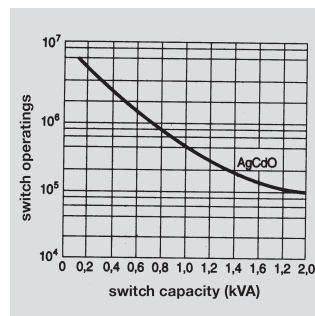

Choosing the time range

The time range is chosen by turning the rotary switch for the ON-time scale and OFF-time scale. The time scales are visible in the display to the left of the rotary switch in the following order: 0.1 s, 1 s, 0.1 m, 1 m, 0.1 h, 1 h.

Note:

The time scales “1 s” and “0.1 h” are given twice. Both adjustments represent the same time scale.

Locking/unlocking of selectors and time setting dial

The rotary switches for the ON/OFF time adjustment and the option selector for the time scale can be locked with the locking key.

This pen-style special tool is available separately. To lock either rotary switches or the option selector, simply insert the locking key into the keyhole bottom right of the rotary switch/option selector and turn it clockwise until the knob/switch is totally covered by the red cover. To unlock, simply turn the key in the opposite direction.

Connection system

The units offers the following connection technologies:

Screw connection

- 2 x 1.5 mm² with wire end ferrule
- 2 x 2.5 mm² without wire end ferrule

Tension clamp connection

- 2 x 1.5 mm² with wire end ferrule
- 2 x 2.5 mm² without wire end ferrule

Dimensions

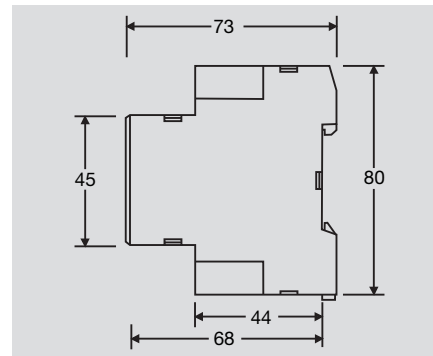

Screw connection

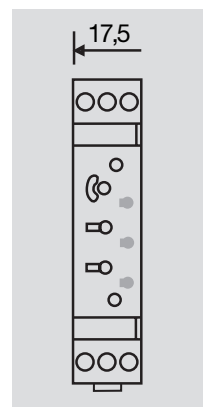

Tension clamp connection

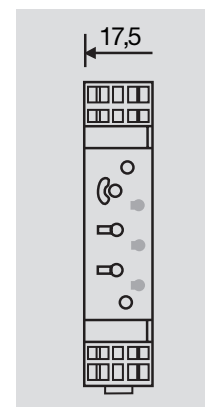

Time relays – BT SERIES

Installation time relays

- Screw or tension clamp connection
- LED status indicator Input: voltage present
Output: output active
- Approvals

<ul style="list-style-type: none"> UL 508 EN 61812-1 IEC 60947-5-1 IEC 60664-1 EN 55011 	<ul style="list-style-type: none"> CE 22.2 Nr. 14 IEC 60664-1 EN 61812-1 IEC 60947-5-1 EN 50082-2
--	--



Type designation:

- B** = Building
- T** = Timer
- R** = Response Delay
- TT** = Two Times
- M** = Multifunction, 8 ranges
- MF** = Multifunction, 4 ranges
- DS** = Delta, Star
- S** = Screw
- Z** = Tension

Input		Contacts hard gold plated	
Rated voltage		24 ... 230 V AC, 50/60 Hz, 24 ... 48 V DC	
Voltage tolerance		85 ... 100 % of rated voltage	
Breaking voltage		Max. 2.4 V AC/V DC	
Power consumption per type	V AC	21 ... 33 VA at 230 V	
	V DC	0.6 ... 1.3 W at 24 V	
Reset time		Min. 0.1 s (BTDS: 0.5 s)	
Insulation			
Insulation resistance		100 MΩ min, at 500 V DC	
Insulation test voltage			
	between input and output, to enclosure	2000 V AC, 50/60 Hz, 1 min	
	between non-adjacent contacts	1000 V AC, 50/60 Hz, 1 min	
Ingress protection class		IP30, terminal block IP20	
Output			
Contact/contact material		1 change-over contact (BTDS 2 NOC) / AgNi 90/10	
Switch output		5A at 250 V AC, resistive load (cos φ = 1)	
Service life	mechanical min.	10 ⁷ switching cycles (no load, 1800/h)	
	electrical min.	10 ⁶ switching cycles (5A at 250 V AC, resistive load at 1800/h)	
Time range		0.10 s ... 120 h	
Repetition accuracy		± 1 %	
Other data			
Flammability class as per UL 94		V-2	
Ambient temperature/storage temperature		-10 ... +55 °C / -25 ... +65 °C (without condensation)	
Clamping range (nominal/min/max)	mm ²		
Length x width x height	mm	80.0 x 17.5 x 73.0	

Accessories

Designation	Type	Qty.	Order No.
Locking and adjusting key	BT Lock Pen	1	8659840000

Multifunction relay with control input (BTM)

Ordering data

Connection system	Type	Qty	Order No.
Screw connection	BTM-S	1	8647700000
Tension clamp	BTM-Z	1	8647710000

Functions

Function A – pick-up delay

The set time T begins to be subject to delay when the input signal (A1/A2) is applied.

The output R (15/18) connects the load at the end of the set time.



Function B – pulse emitter (starts at normal setting)

After applying the input signal (A1/A2), output R (15/18) switches the load synchronously and alternately between the normal and operating settings within the set time T. The cycle starts at the normal setting in this function.

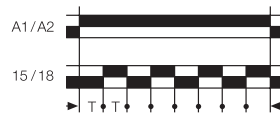

Function B2 – pulse emitter (starts at operating setting)

After applying the input signal (A1/A2), output R (15/18) switches the load synchronously and alternately between the normal and operating settings within the set time T. The cycle starts at the operating setting in this function.

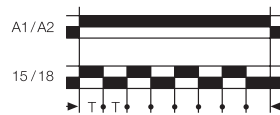

Function C – wipe function

After applying the input signal (A1/A2), output R (15/18) connects the load for the set time T. Output R switches the load off again at the end of time T.

After switching off the input signal (A1/A2), output R (15/18) connects the load again for the set time T. Output R (15/18) switches the load off again at the end of time T.

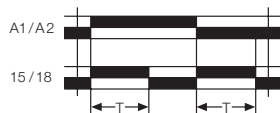

Function D – drop-out delayed

After applying the input signal (A1/A2), output R (15/18) connects the load. The time delay T begins after the input signal (A1/A2) has been switched off. At the end of time T, output R (15/18) switches the load off again.

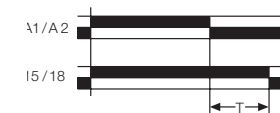

Function E – passing make contact

After applying the input signal (A1/A2), output R (15/18) connects the load immediately.

At the end of the set delay time T, output R (15/18) switches the load off again.

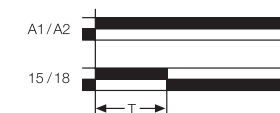

Function G – pick-up and drop-out delayed

Time delay T begins after applying the input signal (A1/A2).

At the end of this time, output R (15/18) connects the load (pick-up delayed).

After the input signal (A1/A2) has been switched off again, the output switches the load off again after the set time (drop-out delayed).

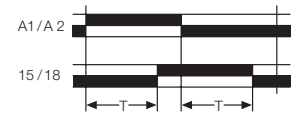

Function J – pick-up delay with pulse

Time delay T begins after applying the input signal (A1/A2).

At the end of this time, the output R (15/18) connects the load for 1 second.



Time relays – BT SERIES

Multi-function relay without control input (BTMF)

Functions

Connection system	Type	Qty	Order No.
Screw connection	BTMF-S	1	8647680000
Tension clamp	BTMF-Z	1	8647690000

Ordering data

Function A – pick-up delay

The set time T begins to be subject to delay when the power supply is applied.
At the end of the set time, the output connects the load.

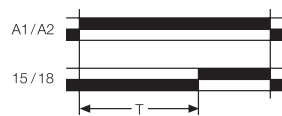

Function B2 – pulse emitter (starts at operating setting)

After applying the supply voltage, output R switches the load synchronously and alternately between the normal and operating settings within the set time T. The cycle starts at the operating setting in this function.

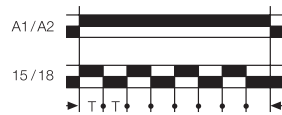

Function E – passing make contact

After applying the supply voltage, output R connects the load immediately. After the set delay time T, output R (15/18) switches the load off again.



Function J – pick-up delay with pulse

The time delay T begins after applying the power supply. At the end of this time, the output R (15/18) connects the load for 1 second.

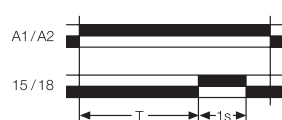

Time relay (BTR)

Functions

Connection system	Type	Qty	Order No.
Screw connection	BTR-S	1	8647720000
Tension clamp	BTR-Z	1	8647730000

Ordering data

Function A – pick-up delay

The set time T begins to be subject to delay when the power supply is applied.
At the end of the set time, the output R connects the load.

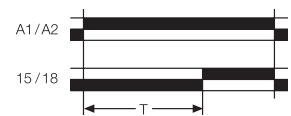

Time relay (BTTT)

Functions

Connection system	Type	Qty	Order No.
Screw connection	BTTT-S	1	8647740000
Tension clamp	BTTT-Z	1	8647750000

Ordering data

Function BTTT – pulse emitter

After applying the supply voltage, the repeat cycle begins with two independently adjusted times. The standard setting is to begin with the normal setting. A bridge between connections A1 and A2 allows the module to begin at the operating setting.



Time relay (BTDS)

Functions

Connection system	Type	Qty	Order No.
Screw connection	BTDS-S	1	8647660000
Tension clamp	BTDS-Z	1	8647670000

Ordering data

Star-delta change-over

After applying the supply voltage, output R1 (17/18) connects immediately. At the end of time T1, output R1 (17/18) switches off and time T2 starts. At the end of time T2, output R2 (27/28) connects. After switching off the supply voltage, output R2 (27/28) switches off.

